

NOT FOR QUOTATION  
WITHOUT PERMISSION  
OF THE AUTHOR

PROCEEDINGS OF TASK FORCE MEETING I  
ON REGIONAL DEVELOPMENT PLANNING  
FOR THE SILISTRA REGION  
(BULGARIA)

Ake E. Andersson  
D. Philipov  
*Editors*

May 1979  
CP-79-7

*Collaborative Papers* report work which has not been performed solely at the International Institute for Applied Systems Analysis and which has received only limited review. Views or opinions expressed herein do not necessarily represent those of the Institute, its National Member Organizations, or other organizations supporting the work.

INTERNATIONAL INSTITUTE FOR APPLIED SYSTEMS ANALYSIS  
A-2361 Laxenburg, Austria



## PREFACE

Regional policy problems are universal. This means that all countries need good methods for analyzing and solving their regional problems. Models for regional policy making and planning have also been worked out in scientific institutions. It is obvious that these abstract models are often not specific enough to be used in policy making but have to be adapted to the institutional, historical and natural conditions of the specific region to be planned. It is one of the ambitions with the Silistra regional case study, reported in this volume, to test the possibility of applying regional policy models, developed in Bulgaria, at IIASA and elsewhere, to the solution of the Silistra development problems.

Some of the models suggested for the Silistra case study are presented in this volume. These models should, however, not be viewed in isolation but as parts of a general systems approach. The papers by M. Albegov and A. Andersson/A. La Bella give examples of possible systems approaches to integration of regional policy models into a consistent system.

This volume basically contains papers on model design. Few papers report on actual use of the models in applications for policy making. The application of these models is planned to be reported in later Task Force Proceedings, when the work has progressed into a stage of close cooperation with the decision makers and national economy planners of the Silistra region. We also have the ambition to come to a stage of generalization of the modeling experiences gained in this case study so that other countries can benefit from the experiences gained in the Silistra case study.

Murat Albegov  
Task Leader  
REGIONAL DEVELOPMENT  
TASK



## CONTENTS

### PART I DESCRIPTIVE FACTS AND POLICY ISSUES

General Trends in the Social and Economic Development  
of the Silistra Region 1  
*M. Devedjiev, N. Grigorov and A. Atanassov*

Basic Development Principles of a Human Resources  
Model for the Silistra Region 11  
*Nikolai Naumov*

Human Settlement Systems as a Device for Development  
and Improvement of the Settlement Network in the  
Silistra Region 21  
*M. Devedjiev, N. Grigorov and A. Atanassov*

### PART II SYSTEMS OF MODELS FOR REGIONAL DEVELOPMENT

A Possible Methodology for an Economic Growth Analysis  
(Of the Silistra Region) 33  
*Murat Albegov*

A System of Models for Integrated Regional Development:  
An Application to the Silistra Case Study 70  
*Ake E. Andersson and Agostino La Bella*

An Information Retrieval and Analysis System: The  
Interface Between the Object of Study and the  
System of Models 136  
*K. Evtimov, N. Grigorov and D. Kebedjiev*

PART III	MODELING OF SUBSYSTEMS	
	Analysis and Simulated Projections of the Population of the Silistra Region <i>Dimiter Philipov</i>	145
	Migrations in the System of Models for Integrated Territorial Development <i>Boris Mihailov</i>	180
	Modeling the Health Care System <i>E.N. Shigan, D.J. Hughes and P.I. Kitsul</i>	212
	A Model for the Development of the Agro-Industrial Complex "DRASTAR" <i>G. Gavrilov, S. Stoikov, H. Milenkov and A. Kehaiov</i>	232
	A. System of Models for Water Resources Development <i>I. Gouevsky, S. Stoykov, V. Genkov, A. Stanoulova and B. Topolsky</i>	257
	A Water Supply Model for the Silistra Region <i>M. Albegov, V. Chernyatin and A. Stanoulova</i>	293
	A Complete Economic Model of One Product <i>Nikolai Kolarov</i>	304
PART IV	LIST OF PARTICIPANTS	327

PART I

DESCRIPTIVE FACTS AND  
POLICY ISSUES





GENERAL TRENDS IN THE SOCIAL  
AND ECONOMIC DEVELOPMENT OF  
THE SILISTRA REGION

M. Devedjiev, N. Grigorov,  
and A. Atanassov

The task, which gathered us at the present Task Force Meeting on the Silistra region, obliges us to try to convey the most detailed information in condensed form about the state of the region and our intentions and views concerning its development.

We must point out that the systematic approach and its practical application in the development of the economic and social spheres in Bulgaria have long ago become the object of attention and decisions of the Government. Intentions of the state authorities concern the establishment of the best conditions for the building and functioning of all objects and activities from the spheres of labor, dwellings, recreation, public services, and population migration. They are directed to the effective utilization of all resources of the country and the satisfaction of the multifarious and continuously increasing social needs. The execution of those intentions is naturally connected with environment and resources.

In our age of rapid growth and structural change, the ecology as well as the economy must be considered in a long-term perspective. That is the reason for our wish to choose a complex approach in our study and to consider the requirements of the

branches of social and economic activity, as well as the requirements and needs of society today, tomorrow, and in the future.

Those were the considerations and backgrounds for choosing Silistra as the object of our cooperative activities.

#### NATURAL GEOGRAPHIC CHARACTERISTICS

The Silistra region occupies the outlying northeastern part of the territory of Bulgaria and covers an area of 2860 km<sup>2</sup>, or 2.6% of Bulgaria. Its population numbers 176,000 persons, or 2% of the total population. Silistra is one of the smallest and least populated regions in Bulgaria. The great distance from the main economic centres of the country and some other specific factors have determined the peculiarities in the social and economic development of the region. The region produces 1.2% of the national industrial production and 4.7% of the agricultural production. About 66.8% of the working population in the region is occupied in those two branches, while the remaining are occupied in the developing area of public service.

When we consider the results achieved in the economic area and the historical factors, we may look optimistically towards the future. In 1939, the region was considered a backward and primitive agricultural district, while now we are proud of its great achievements in agricultural production and the production of computing equipment, which is sold in many countries.

Of course, when we judge the future of the region, we should bear in mind the great national tasks, and study the physical and geographic conditions that make the Silistra region favorable for the development of agriculture. Here are included a part of the Danube hilly plain, the Dobrudja plateau and the northern parts of the Ludogorsko plateau. The region has mostly plains and hilly-plains. It favors the development of a highly mechanized agriculture.

Engineering and geologic research activities have not found ore deposits. Of practical significance is only the kaolin deposit near the village Kolobar. There are also quarries for

building materials situated in the waterless southeastern and northeastern plains of the region.

The climate is moderate-continental. The winter is comparatively mild. The average temperature for January is from  $-1^{\circ}$  to  $0^{\circ}$ C. The average July temperature is  $21^{\circ}$  to  $23^{\circ}$ C. The annual precipitation is between 500 and 550 mm/m<sup>2</sup>, with maximum rainfall in summer and minimum in winter. The water resources are rather restricted. That is determined by the loess surface layer and the limestone layers, which quickly absorb water. Except for the Danube, there are no surface waters.

The fertile soils are the most precious natural resource of the region. They create very favorable conditions for the intensive development of agriculture.

#### NATIONAL REQUIREMENTS AND BASIC FUNCTIONS IN THE DEVELOPMENT OF THE REGION

Proceeding from the above overall characteristics, the further social and economic development of the region must be realized on account of national criteria and requirements and local potentials of the territory and the specific natural geographic conditions and resources.

One of the most important national requirements is the effective utilization of the territory of the whole country and of the region, in particular, as well as the decreasing of migration to optimal rates, development of an efficient economy and optimal use of the natural, material, and human resources of the region. Another significant task is the establishment of optimal conditions of labor, living, recreation, migration and services for the population as regards not the present but the future needs of the people. Those needs must be satisfied on the basis of the most progressive technologies in all spheres of human activities. To bring national requirements in accord with local conditions and resources, these should be directed towards: the discovery of the territorial potentials, the optimal match between the branch and territorial concentration and

specialization of economics, the construction of a unified technical and social infrastructure and the improvement of the region's settlement network.

In accordance with these tasks and based on natural conditions and resources, the transport-geographic situation, and the level of social and economic development, the basic functions of the region are determined:

1. agricultural function;
2. transport-communication function;
3. industrial function, connected with using the Danube's potentials; and
4. industrial function connected with the further development of industrial activities that are traditional for the region, for instance: machine building, computing equipment, light bulbs, souvenirs, etc.

The exact trends and requirements for the development of those functions by means of a correlation between national and local criteria and requirements are determined as follows.

#### *Agricultural Function*

By the development of those functions in perspective, we aim at revealing the possibilities for a rational use of the resources available in the region: land, production capacities, using of other countries' achievements, to develop a perfect agriculture with a complete production cycle on the principle "land-product".

The main strategic trend in agricultural development is grain production and stock breeding. In the area of grain production, specialization will be accomplished with a further improvement of crop production at the regional level. This will create conditions for planting large homogeneous crops—an important condition for the application of industrial methods and technologies on worldwide level and the use of highly productive techniques.

In the field of stock breeding, specialization is oriented towards cattle and swine breeding. Most important is milk cow breeding and the fattening of male calves. The increase of the number of cows will be achieved by means of intensified reproduction and import of highly productive breeds from other countries.

The development of the agricultural function of the future will be accomplished under the conditions of an improved utilization of land resources in the region by means of increasing the quantity of arable land and the coefficient of utilization. The production of milk and meat will be done by means of modern technologies, with consideration of international market requirements.

#### *The Transport-Communication Function*

The presence of the Danube and the favorable geography and transportation of the region make this function a priority in the future, though now it is underestimated. At the moment, the water, auto, railway, and air transport is insufficiently developed.

The water transport is not of a great significance at present, both for the region and for the country. The Silistra harbor is insufficiently equipped. The continuous cargo-exchange along the Danube, the small distance between Silistra and the Soviet harbors, the future construction of the Rhine-Marne-Danube canal, and the construction of industrial works located on the Danube for import of raw materials and export of products to the East and to the West--are the premises for a rapid development of water transport.

The railway transport satisfies the necessities only of the region and does not possess a well-developed national function. The construction of a port complex in the Silistra region and the improvement of the railway network in northeastern Bulgaria will increase the significance of the railway transport and it will receive important national functions.

Thus, by means of the water transport, connected with railway and auto transport, favorable conditions will be created for the activation of regional development.

*Industrial Function Connected with Using the Danube*

The northern boundary of the Silistra region is connected with the Danube. At present, it does not significantly affect industrial development. That is why, when evaluating future possibilities of the territory for the location and development of various industries, that fact must also be considered.

It is possible to establish plants whose functioning is connected with the import of goods by ship, the using of the Danube waters for technological purposes, and the export of national as well as regional products for the countries of Central Europe and the Soviet Union.

The construction of a great forest-industrial complex in Silistra has already begun. It is built on wood imported from the Soviet Union. It will use huge quantities of water for its production, and part of its production will be exported on the Danube.

The possibilities for location of other industries are also being investigated.

*Industrial Function, Connected with the Further Development of Traditional and Experimental Activities*

The industrial manufacturing is realized, at present, in 39 plants of central subordination and 11 of local subordination. The structure, concentration, and specialization of those works meet the requirements of international standards. The proposals for industrial development made by various ministries further developed the historically formed specialization, structure, and concentration of production in practice.

The industrial production must progress in accord with the following strategic trends, determined by means of matching the proposals of central department authorities to the local territorial requirements:

- computers and duplication equipment;
- aggregate cutting and large-scale metal-cutting machines;
- mechanical toys;
- production of consumer goods and food and wine industry.

#### Computer and Duplication Equipment

These have the greatest prospects for further development in the following directions: production of electronic calculators, electronic cash registers, minicomputers, copying and duplicating equipment, printing plates, electronic watches, etc. With a view to the improvement of the structure of management and production, it is useful to differentiate among three plants with the following specializations:

- a plant producing computers;
- a plant for copying and duplication equipment;
- a plant for printing plates.

The activities of those plants will be coordinated by economic plans.

#### Mass cutting and large-scale metal-cutting machine production

The machinery industry of the region is concentrated in 11 plants. The small scale and variation of production hinders the modernization in this branch and necessitates restructuring of the existing production programs.

It is useful to accomplish concentration and specialization of production by centering production in three places:

- metal-cutting machines in the region of the city of Silistra;
- agricultural machine building in the region of Duloovo;
- utility machine building in the region of Tutrakan.

The number of machine-building works will be significantly reduced and combining of plants will be made according to the requirements of technical progress and international practice.

## Mechanical Toys

The production of mechanical toys is a characteristic link in the specialization of industrial production in the region. The prospects for this region are based on the tradition and professional experience of the population and it will be developed in the city of Silistra.

## Consumer Goods

At present, consumer goods are produced by 11 plants, located in a large number of settlements and grouped into two combines. According to the economic plan, a significant part of the basic production will be transferred from Silistra to other cities to employ free manpower and favorable living conditions.

## PROBLEMS OF THE DEMOGRAPHIC AND SOCIAL DEVELOPMENT OF THE REGION

The economic development of the Silistra region has affected and will further affect the social sphere. The discrepancy among the rates of development of industry and transport, as well as the rapid implementation of mechanization in agriculture have brought about migration processes. They are characterized by the following specific features:

- population emigration towards other regions of the country;
- internal migration to the towns of the region, mostly towards Silistra.

This migration mechanism has participated in the formation of the demographic characteristics of the population in the region. There are areas of population growth with a normal age structure. Such areas are: the region of Silistra-- Kalipetrovo and Aidemir; the region of Tutrakan and the region of Dulovo. At the same time, there are regions where population is decreasing with abnormal age structure.

Those migration processes have been significantly influenced by the predominant localization of industry in the Silistra region, which has caused:



- creation of policies for the restriction of migration within the region as well as outside of it;
- population stabilization by increasing production and service functions;
- improvement of the regional road network, organizing bus transportations for passengers between cities;
- improvement and modernization of existing housing and building new housing of high quality, mostly in the poorly developed centers of settlement systems, such as Glavinitsa, Sitovo, Sredishte and Alfatar;
- establishment of a unified complex public service system--trade, health, education, culture, etc.;
- development and realization of a series of enterprises for sanitation and urbanization of the settlements in the region; and
- establishment of objective premises for the equalization of the conditions of labor, dwelling, public services and recreation in the villages and towns of the region.

#### CONCLUSION

The solution of the problems and tasks set for the Silistra region cannot be achieved without application of objective methods and contemporary techniques.

Problems similar in character and possibilities for their solution exist in other regions of the country, as well. This allows the cooperated research activities between our country and the International Institute for Applied Systems Analysis, in Austria, to be transferred over a wide territorial scope. Thus, the local results, which will be obtained for the Silistra region, acquire substantial significance in two ways:

1. On the basis of the system of models for an integrated development of the Silistra region, a project will be worked out immediately directed towards practical implementation.

2. Conditions are created for the application of the systematic approach in other regions of the country as well, thus unifying the system of information.

That will also become a means to the further information supply of other regions in the country and to the improvement of the data on a territory.

Such are our initial positions and considerations in the reports, proposed to your attention at the present meeting. They must be accepted and discussed as a primary stage in the fulfillment of our great task, and that is why all comments and opinions on them will be accepted with gratitude.

BASIC DEVELOPMENT PRINCIPLES OF  
A HUMAN RESOURCES MODEL FOR THE  
SILISTRA REGION

Nikolai Naumov

INITIAL HYPOTHESES AND CRITERIA

Population growth must correspond to the foremost objective--further stimulation of the regional economic growth, which is, after all, the premise for continuous growth of prosperity. That must be the background for determining criteria of "optimal" human resources growth comprising the demographic development and some basic qualitative characteristics of the people. Hence, the general formulation of the optimum criterion might be presented as follows: "The manpower needs are satisfied on account of the expected growth as regards total number, professional and qualification structure, and territorial sector distribution."

A broader concept of the demographic growth places the demographic model in relevant links and interrelations with the models of economic growth and social progress of communities. On this basis, a complex system of undertakings in the total economic and social policy for the regional development may be analysed.

The population growth of the region as a whole must be a basis and background for the solution of the optimum problem,

without ignoring its territorial position on the level of "Settlement systems." With regard to the meeting of manpower necessities, the requirements concerning age-sex structure by main production sectors are also of importance. This is of a particular significance for agriculture, where strong tendencies to unfavorable structure formation are observed.

Given a solution to the problem of manpower supply, with numbers based on population growth, we might be confronted with the following basic situations:

- demographic growth with tendencies above the optimum;
- demographic growth with tendencies below the optimum;
- demographic growth with tendencies close to the optimum.

It must be assumed that there exist no reasons for conducting demographic policy differing from the one which is designed for the whole country--accelerating the rate of demographic growth by means of a system of enterprises for encouragement of births and decrease of mortality.

In all situations, the achievement of the optimum must be realized on the basis of a purposeful migration policy concerning combinations of the following ideas:

- attraction of in-migrants;
- out-migrants stimulation;
- essential restriction of migrations.

It is clear that the migration problems in the regional policy are not solved by migrations from the region or towards the region. There also exist problems of intraregional migration, for instance, migration among the settlement systems within the region, as well as problems of daily labor commuting within a region and between the regions. Migration policy decisions cannot be obligatorily connected only with the number of the constant population of the region and its settlement systems. Those are problems of a search for optimal decision, rendering an account of the possible changes in age-sexual structure of the constant population and the eventual consequences of population reproduction and labor resources in

perspective, generally speaking, to the possibilities for achievement of the desired results, etc.

In this case, there is an increased significance of a selective migration in accordance with the satisfaction of requirements for manpower with professional qualifications, education, and other characteristics.

The optimization of demographic growth, mainly in terms of meeting manpower needs, is related to the determining of those needs in a sector-territorial and professional-qualification aspect. That requires a purposeful education policy, on the basis of the regional and national education systems. In this connection, the problems arise of youth professional orientation and the development of an education network in the region and in other regions. Those problems must be solved on the basis of prognoses about the number and structure of the necessary manpower in a sector-territorial aspect. That might also be the background for solution problems of manpower supply, of the development of all branches of social and economic life, of the distribution and redistribution of manpower, requalification, qualification improvement, etc. That is why the indicated pronoses take a central position in the uniform model for population growth in the region.

The maintaining of a constant demographic growth depends, to a great extent, on the designed economic and social development of the region, which must take account of human resources available in the region. The provoking of large migrations and, in particular, the need of attraction of a higher number of in-migrants, is connected with great expenses and difficulties of a varied character. It might reflect the age-sex structure of the population and the character of its growth in perspective, in the region under study, as well as in a series of other regions of the country, with which an interaction might be established. The variations of the optimum in time must also be considered and they should not be great and sudden in order to be realized without substantial difficulties and expenses and without creating problems to other regions. It is very important

for the regional structure to be able to establish conditions for male and female work, taking account of the high degree of the employment of women in the country related to the maximal utilization of human resources. The purposeful policy of a greater or smaller activity rate for pensioners is also important and might make solution of the problems easier. In general, the demographic optimum may be achieved and successfully maintained, when the planned economic development takes account of the character and reproduction of population and labor resources. That is of particular importance in countries like Bulgaria, where, in essence, there exists full employment of active population.

The complete development of a human resources model could not be realized under the now existing statistical information, but it should be mentioned that in broad lines the realization of such a model is possible. The fact that the number of the population in the Silistra region is only 180,000 persons, 90,000 of them active, is favorable. Under the existing administrative-management structure and administrative apparatus, without any significant difficulties and expenses, some additional information might be collected. Such an initiative will be particularly useful as regards the work done for the development of an integrated system for social information in the country that might render assistance in the development of and experimentation with information models in accord with the information necessities of application of more thorough prognosis models.

SOME BASIC CHARACTERISTICS OF THE DEMOGRAPHIC GROWTH  
AND ECONOMIC ACTIVITY OF THE POPULATION  
OF THE SILISTRA REGION

General characteristics of the population growth and its economic activity might contribute to the motivation of the presented approach for modelling the population growth in the region. However, it will be useful to relate these characteristics to those of the Northeastern region of the country, to which the Silistra district belongs.

The Northeastern region as a whole, as well as the Silistra region, has a natural growth in population, significantly exceeding that of the country as a whole. The average annual birth rate for the region during 1972-1976 was between 16.5 and 19.4 per 100 people and the natural growth in population varied between 8.0 and 9.4% during the same period. During the same period, in the Silistra region the annual birth rate varied between 17.3 and 20.7 per 100 people, and the natural growth of the population between 7.1 and 11.9%. It must be mentioned that during this period significant fluctuations in the birth rate take place, as happens in all other regions of the country. This is due to the introduction of a series of undertakings to encourage population growth since 1967.

Considering the period of the last three population censuses (1956, 1965, and 1975), we may point out the high total population growth in the Northeastern region, which is significantly higher than that in many other regions and in the country as a whole.

In 1975, the population increased by 18.6%, compared with 1956, and after 1965 the growth rate gradually decreases. As for the Silistra region, a lagging behind in this growth is observed, and its value is 7.5% in 1975, as compared with 1956.

The population age structure during 1956-1975 shows an aging tendency from the top and from the bottom of the age pyramid. When comparing the Northeastern region with the rest of the country, it must be mentioned that this aging process is rather less intense, and as concerns the population of Silistra region itself--the process is far less intense. Here the population under 20 is about 35% of the total, and the population more than 60 years old is only about 12%--indices which present the regional population as still young in age structure.

Those of reproducing age in the Northeastern region as a whole and those of the Silistra region during the period considered, grow in number, at the same rate as the population as a whole. Their number is 25-26% of the total population. The same is valid for the population aged from 16 to 60 and

representing the basic manpower resource; its number remains 60 to 62% of the total population of both the Northeastern region and Silistra region.

The population growth rate in the Northeastern region and in the Silistra region as compared with the growth rate in the whole country exhibits a high natural growth. Under those circumstances, the population grows with increasing possibilities as regards reproduction potential and labor resources. The age-sex structure of the population and fertility of families are, generally speaking, among the most favorable in the whole country. Thus, they create premises for maintaining a comparatively high demographic growth.

The Northeastern region is developing with a negative migration balance, on the whole. Only one of the districts in this region--the Varna district--is continuously growing with a positive migration balance. The Russe district during the recent years had a positive migration balance and in earlier years a negative migration balance. The Silistra district and all the remaining districts, except for the two mentioned above, are continuously growing despite a negative migration balance. It must be mentioned that, during the period 1972-1976, the migration balance of the Silistra region covered 17% of the total negative migration balance in the region (its population was 9.9% of the total population in the Northeastern region at the end of 1975).

The analysis of migration shows that the basic reason is people's labor activities. The migration of the economically active forces the migration of people depending on them. This is valid for the migrations in the whole country, in the Silistra region, and in the Northeastern region.

The labor migration could not be related to the lack of employment at all, though such cases exist. According to data from the inquiry made in 1975 and including all economically inactive persons of employable age, but excluding students, in the Silistra district only 0.4% of this category of persons have given the reason "lack of suitable employment" (which might be



considered as a certain kind of unemployment). The migration analyses and their relation to economic activity show that the wish to out-migrate is not brought forth by the lack of employment in general, and to a very low degree by lack of suitable employment. The decision to out-migrate is engendered by other reasons that are to a degree social-psychological ones. The character of social and economic growth creates premises for search for other employment, with aspirations for better working conditions, better living conditions, higher wages, more cultural facilities, better services area, etc. Without any intention to give details, we would like to point out that the foreseen economic growth of the region under the conditions of a purposeful social policy could very easily prevent out-migration to a very high degree, at least as far as is necessary to maintain the optimum. By the way, that is shown in a series of characteristics of the population labor occupation in the Silistra district.

In broadest lines, the occupations of the economically active population in the Silistra district by industrial sectors (excluding the city of Silistra) in 1975 is presented as follows:

Table 1. Occupation of economically active population by sectors (%).

Areas and main sectors	Silistra	Northeastern region
Material sector	88.0	34.0
Non-material sector	12.0	14.0
Total:	100.0	100.0
Industry	26.5	28.0
Agriculture	44.6	34.7
Other sectors	23.9	37.3
Total:	100.0	100.0

From the table, one sees that the main part of the economically active population in the Silistra district occupied in the material sector works mainly in agriculture. Agricultural employment in the whole Northeastern region is substantial, as compared with the country as a whole (agriculture employed 28.3% of the population of the country in 1975).

To this end, the structure of the national income is of interest, and is presented below in Table 2.

The structure of the national income by sectors reflects to a great extent the occupation of the economically active population by sectors.

The national income per person occupied in material production in the Silistra region is 10.5% lower than in the Northeastern region. In this aspect, there are substantial differences by sectors, for instance: in industry the national income per employed person in the Silistra region is 19.4% lower than in the nation, while in agriculture it is 16.3% higher, and in all remaining sectors of material production it is 9.4%.

The basic production fund supply per economically active person in the Silistra region is 47.1% lower than in the Northeastern region. The wage of those occupied in industry is 6.5% lower, and in agriculture 9.9% lower.

Table 2. Structure of the national income by sectors (%).

Main sectors	Silistra	Northeastern region
Industry	35.4	42.3
Agriculture	41.5	25.5
Other sectors of material production	23.1	32.2
Total:	100.0	100.0

In the whole Northeastern region the wages in agriculture are 3.4% lower, on the average, than in industry.

The public service area (education, health, housing municipal economy, culture, etc.) in the Silistra region is substantially less developed than in the remaining part of the Northeastern region.

To conclude, we may say that under the existing conditions, there are favorable possibilities to control the migrations in order to reach a specific balance necessary for maintaining the optimum. It is in the migration policy where we must search for radical solutions to population problems.

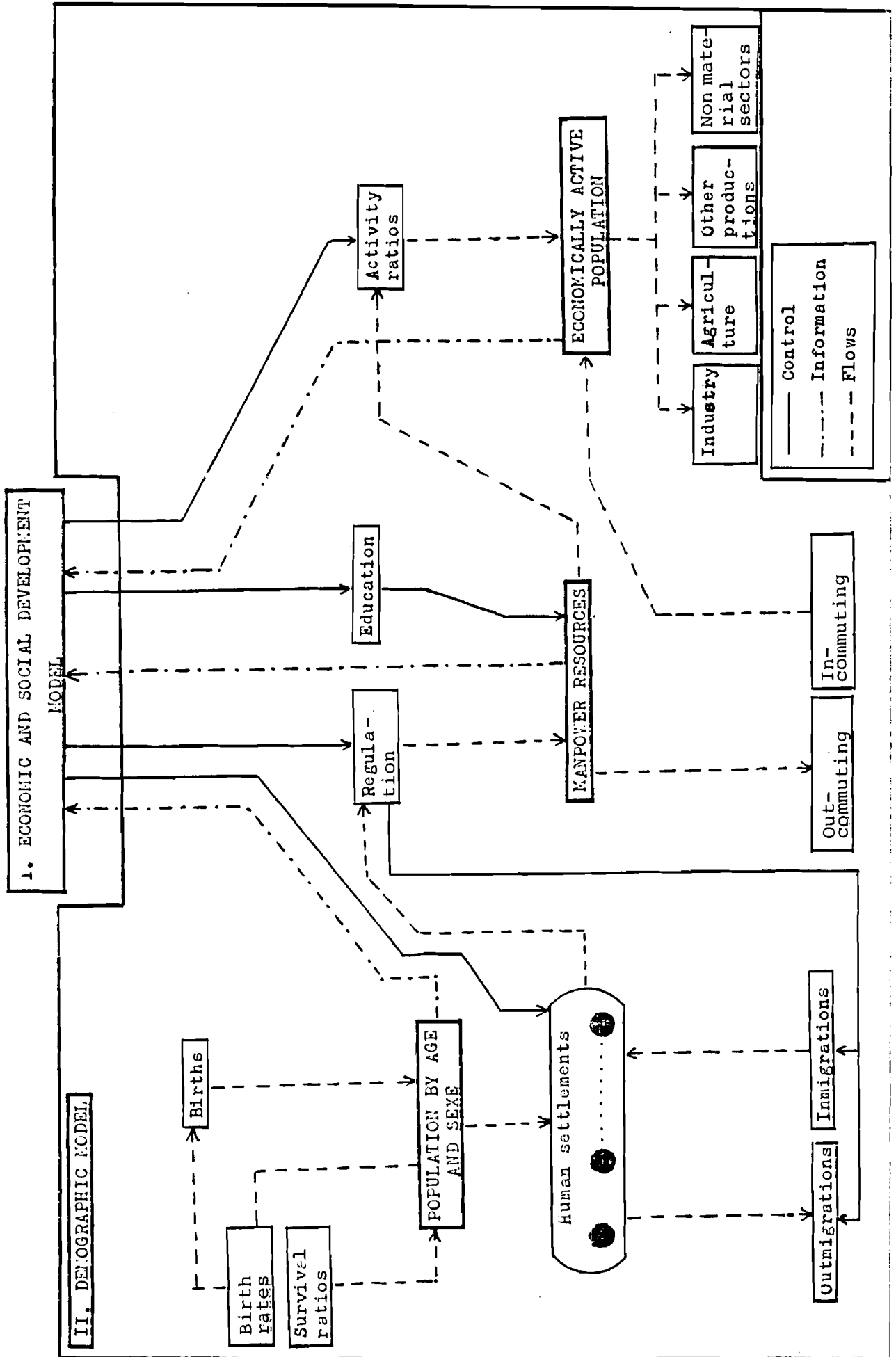

Diagram 1.

HUMAN SETTLEMENT SYSTEMS AS A DEVICE  
FOR DEVELOPMENT AND IMPROVEMENT OF THE  
SETTLEMENT NETWORK IN THE SILISTRA REGION

M. Devedjiev, N. Grigorov and  
A. Atanassov

All functions connected with "labor", "dwelling", "recreation", "public service" and "migration" are realized in the settlements in the Silistra region. The regularities in settlement number variations and population number variations clearly testify to the changes in their economic settlement-formation background. This would be the principle of development of models for improvement of the regional settlement network. Here, the regularities in industrial and agricultural changes, the development of the third sector--public services and the demographic processes accompanying them --must be considered.

The retrospective analysis shows that the appearance of settlements in the region may be related to different historic periods. The city of Silistra, for instance, appeared in historic records during the first century A.D.--the Roman epoch by the name of Durostrum. During the period of the first and second Bulgarian kingdoms (X, and XIII, and XIV centuries A.D. respectively) it existed under the name Drastar. Throughout its nineteen centuries of existence, Silistra has been fulfilling substantial military-defensive functions and was known as an outstanding fortress in that region of the

Balkan peninsula. Shortly after the Liberation of Bulgaria in 1878, the town started gradually losing its military-defensive functions and because of poor economic growth, it started declining.

Another ancient town, founded during the existence of the Roman empire, is Transmariska, now named Tutrakan. The name of the village Kainarja is also historically recorded in connection with the peace treaty between Turkey and Russia, signed there in 1892.

Almost all remaining settlements were begun during the second half of the VIII century and the first half of the IX century. They may be characterized mainly as agricultural and stockbreeding settlements and they have influenced the structure of the settlement network in the region.

#### STATE OF THE SETTLEMENT NETWORK IN THE SILISTRA REGION

In 1975, the number of settlements in the region was 116, consisting of 4 towns and 112 villages. On an average there are 4.0 settlements per 100 km<sup>2</sup>, which is below the average density for Bulgaria of 4.6 settlements per 100 km<sup>2</sup>. This testifies to the comparatively high degree of settlements concentration in the region, in spite of its plains and prevailing agriculture.

The city population--82,766 persons or 46.9% of the total regional population--is distributed among four cities. In one city live about 20,690 persons on the average. Silistra is the largest city (58,197 persons) and Alfatar the smallest (3,250 persons).

The village population is 93,662 persons, or 53.1% of the total population. There are 112 villages and the average number of inhabitants per village is 830 persons. The largest village is Kalipetrovo with 6,448 inhabitants, while the smallest one is Yastrebna with 21 inhabitants. The population distribution into separate agglomeration groups of settlements is as follows (see Table 1):

Table 1. Population distribution in the settlements in Silistra region until 1975

1	2	Settlements		Population		Average
		number	%	number	%	7
		3	4	5	6	7
<b>Villages</b>		112	96.6	104339	59.4	932
1.	Very Small (0-200 persons)	13	11.2	1876	1.1	144
2.	Small (200-1000 persons)	60	51.7	32882	18.7	548
3.	Average (1000-2000 persons)	29	25.0	39782	22.6	1372
4.	Large (2000-5000 persons)	9	7.8	23351	13.3	2595
5.	Very Large (5000 or more)	1	0.9	6448	3.7	6448
<b>Towns</b>		4	3.4	71415	40.6	17854
1.	Very small (below 10000 persons)	2	1.7	13144	7.5	6572
2.	Small (10000-30000 persons)	1	0.8	11425	6.5	11425
3.	Average (30000-100000 persons)	1	0.9	46846	26.6	46846
<b>Total for Silistra region:</b>		116	100.0	175754	100.0	1515

A characteristic peculiarity of the region is the fact that 59.4% of the total population live in 96.6% of the village settlements, while in the remaining 3.4% city settlements are concentrated 40.6% of the population.

The average population in one village settlement is 830 persons, while in city settlements, it is 17,854 persons.

39,782 persons, 22.6% of the population, are concentrated in 29 settlements with populations from 1000 to 2000 persons. The average population per settlement of this agglomeration group is 1,372 persons.

In the 30,000-100,000 agglomeration group belongs the regional center Silistra, in which the largest group of people --46,846 persons--is concentrated.

The overall evaluation of the regional settlement network is directly connected with its agricultural characteristics.

SPATIAL ANALYSIS AND TENDENCIES OF THE SETTLEMENT NETWORK DEVELOPMENT IN THE SILISTRA REGION

The settlements are comparatively uniformly distributed in the territory of the region, which is attested to by the average distance between them--3.0 km. There are several regularities in population territorial distribution, according to categories of settlements and average distances (see Table 2).

With the increase of the population number in a certain group of settlements, the average distance between them also increases, varying with 2.9 km for very small villages and 7.6 km for very large villages. That is the background for the development of the hierarchy of the separate settlements of the region.

In the structural aspect, the settlement network of the region may be characterized as polycentric, because its center (Silistra) had 26.6% of the total population and 62.8% of the town population, in 1975. This peculiarity of the spatial structure has also influenced the development of independent settlements possessing their own centers and areas of activity.

Table 2. Average distances between settlements from different categories

Settlement type	Average distance between settlements
1. Very small villages up to 200 persons	2.9 km
2. Small villages from 200 to 1000 persons	2.8 km
3. Average villages from 1000 to 2000 persons	3.0 km
4. Large villages from 2000 to 5000 persons	4.2 km
5. Very large villages more than 5000 persons	7.6 km



The intensive development of industry and the rapidly increasing manpower necessity in industrial centers brought about an intensification of commuting not only within the settlements but also between them.

That was the basis of the differentiation of commuting regions (see Table 3).

Almost 10% of the region's working population do not work where they live. This percentage has been growing during the last years and it is indicative of the formation of a territorial-industrial complex with specialized functions in the whole region.

The deepening of contacts between the separate settlements' population because of a common workplace is further developed in the area of public service, and is assisted by the hierarchic system of periodic and incidental public service in the field of trade, public catering, health, education, culture, sports and youth activities, administration, transportation and information services.

Those processes, realized under the conditions of the already existing settlement network, helped to a great extent in making it homogeneous and initiated the new type of settlement formations, called settlement systems.

The newly created housing and public service funds, as well as the level of public service organization, contributed to the development of this process (see Table 4).

Table 3. Commuting till 31.XII.1975

Settlements towards which daily labor commuting is made	Number of exit sett.	Number of commuting population
1. Silistra	more than 20	5238
2. Tutrakan	more than 8	350
3. Dulovo	more than 8	856
4. To the remaining 19 settlements	more than 40	1580

Table 4. Available housing till 31.XII.1975

Settlement system	Number of dwellings	Number of rooms	Number of inhabitants
1. Silistra	18996	51850	68775
2. Tutrakan	7909	23828	27249
3. Dulovo	8510	30581	37422
4. Glavinitsa	4520	14604	16409
5. Sitovo	3461	11370	10830
6. Alfatar	2082	6723	6487
7. Sredishte	2655	7378	8537
<b>Total for the region:</b>	<b>48133</b>	<b>146334</b>	<b>175709</b>

The available housing is in a good condition and has been built during the last 15-20 years. There are 3.04 rooms and 3.65 inhabitants per home, on the average, and those indices are satisfactory as compared with those of the whole country.

The standard of housing supply in the region is as follows (see Table 5). Considering the data drawn from Table 5, the conclusion may be drawn that the level of housing supply in the regions is comparatively good as concerns national plans for 1990:

Table 5. Standard of housing supply till 1975

Settlement system	Number of dwellings per 100 families	Number of rooms per 1000 inhabitants	Number of dwellings per 1000 persons
1. Silistra	81	711	259
2. Tutrakan	86	823	269
3. Dulovo	72	800	221
4. Glavinitsa	84	835	257
5. Sitovo	95	969	292
6. Alfatar	90	929	283
7. Sredishte	89	769	275
<b>Total for the region:</b>	<b>82</b>	<b>726</b>	<b>256</b>

100 dwellings per 100 families and 1000 rooms per 1000 inhabitants. Those average indices for settlement systems are as follows: 80 dwellings per 100 families for cities, and 89 dwellings per 100 families for villages. All the above is used as a background for determining the tasks of housing construction in the region which until 1990 will be mainly in its cities.

The level of planning and organization of public service in the settlements (street pavement, water supply, sewers, electricity supply and gardens and parks) is rather satisfactory, but unevenly provided in the settlements of the settlement systems.

The complex analysis of the entire construction of the settlements within the settlement system provides an impetus for finding a new approach for their improvement and development.

#### SETTLEMENT SYSTEMS AS A DEVICE FOR THE IMPROVEMENT OF THE SETTLEMENT NETWORK IN THE REGION

The basic directions for the further social and economic development of the region in accord with the leading functions of its territory and available resources require the application of qualitatively sophisticated concepts of improvement and development of the settlement network.

The principal characteristics of these concepts are the following:

- further development of the polycentric character in the structure of the settlement network in the region;
- effective and purposeful utilization of the existing housing funds in the separate settlements of the region;
- formation of settlement systems and their labor, dwelling and recreation, public service and population migration; and
- control of interregional migration processes;
- organizing regular transport between the settlements, on the basis of intersettlement public transport.

The realization of those principles over the territory of the Silistra region is in accord with the national plan for the improvement of the settlement systems, that is included in the Unified Territorial Plan of Bulgaria.

In the process of formation of settlement systems and assignment of their boundaries, natural geographic, economic, social, technical and administrative factors are considered.

The existing intersettlement connections, based on labor and public service, are strongly determined by the daily labor migration of the population.

Within the boundaries of the settlement systems, the problems of labor, dwelling, recreation and public service are solved with regard to their hierarchic limits and connections. On such basis, seven settlement systems are differentiated in the region: Silistra, Tutrakan, Dulovo, Glavinitsa, Sitovo, Alfatar and Sredishte.

In accord with the statements of the national plan, the settlement systems are classified in three groups on the basis of their economic and social development, population concentration, housing funds and problems to be solved (see Table 6).

To the first type of settlement systems--"A" or "formed"--belong the settlement systems Silistra, Tutrakan, and Dulovo. There the material and technical background of

Table 6. Settlement systems until 1975

Name of settlement system	Territory km <sup>2</sup>	Number of settlements	Population in 1975	Type of settl.sys.
1. Silistra	494.6	19	69000	A
2. Tutrakan	489.3	18	27200	A
3. Dulovo	547.2	26	37300	A
4. Glavinitsa	403.5	19	16500	B
5. Sitovo	259.2	12	10800	C
6. Alfatar	255.9	7	6400	C
7. Sredishte	324.5	15	8490	C

the social area should be further developed, and economics must be developed intensively. It is necessary to improve the structure of the economy and to use the working population efficiently.

However, there exist essential differences in the spatial structure of those settlement systems. The population density in the settlement system of Silistra is 139.5 persons per 1 km<sup>2</sup>, and in its nucleus it is 2354 persons.

At the same time, those indices for Tutrakan have values of: 55.6 persons per 1 km<sup>2</sup> (total for the system) and 211 persons per 1 km<sup>2</sup> in the nucleus, and for Dulovo - 68.3 and 190, respectively.

The formed settlement systems are characterized by high industrial production capacity and a high degree of urbanization. Their economic development and environment development requires a purposeful urban policy for each of the settlements in the settlement system.

A settlement system in the process of formation is represented only by Glavinitsa, the city third in size. Here the problems of the further development of economics concern the complete engagement of the system's active population and the providing of a more varied production structure.

The settlement systems, which should be formed in the region are three: Sitovo, Alfatar and Sredishte. Their population is 25,000 persons and industry is developed to a very low degree.

The most important task of those settlement systems is to stimulate the utilization of their territories and settlements and to create a solid settlement-formation economic background.

The internal structure of any settlement system consists of a center (pointed settlement), nucleus (polycentric) and periphery. The polycentric nuclei are characteristic mostly of the formed settlement systems, while the nuclei of the remaining ones are the local centers of the settlement system.

In the settlement system Silistra, the nucleus consists of the town Silistra and the villages Aidemir and Kalipetrovo. Those are settlements with small distances between one another and particularly intensive contacts.

The remaining settlement systems are characterized by a bilateral internal structure, represented by a pointed center and a periphery. In some of the settlement systems, which should be formed in future, such as Sitovo and Sredishte, the development of two centers is possible at the beginning: Sitovo-Dobrotitsa and Sredishte-Kainardja.

#### DOMINATING ECONOMIC FUNCTIONS OF SETTLEMENT SYSTEMS

The system-formation economic background of the settlement systems is determined according to the trends of social and economic development of the Silsitra region and its dominating functions in the economy. It is based on the already created industrial works and the agro-industrial complex with branch farms.

Bearing in mind the territorial sites of the separate branches of the industrial works and the relations among them, we may conclude that four lower territorial-manufacturing complexes are formed in the region:

- Silistra complex: developing machine building, forestry, food and wine industry and additional manufactures of textile industry, the industry for building materials and goods for public utility. This territorial-manufacturing complex occupies the highest rank in the region, with the greatest concentration of basic funds, industrial production and employment.
- Dulovo complex: developing machine building and green crop production and additional manufactures of textile and tobacco industry. The complex is second in rank and is subordinated to and cooperates with the Silistra complex.
- Tutrakan complex: developing utility machine building and additional manufactures of goods for public utility and textiles. The complex is also second in rank and is subordinated to and cooperates with the Silistra complex.

- Glavinitsa complex: developing machine building and additional textile production.

According to their territorial scope, the above-mentioned four territorial-manufacturing complexes may be identified with the settlement systems Silistra, Dulovo, Tutrakan and Glavinitsa. The remaining three settlement systems - Sitovo, Sredishte and Alfatar tend to specialize in agricultural production, which will influence their spatial structure.

#### CONCLUSION

The analysis of the settlement network reveals some tendencies in its development, which are specific for the region and must be considered in its development planning. They are:

- Comparatively small settlement systems are formed, in which the separate elements-settlements have small distances between one another.
- Each settlement system has its own dominating economic functions, which must be further developed and should be directed to a more effective utilization of local territorial resources.
- The settlement systems in the eastern parts of the region must be stabilized with settlements where agricultural production prevails.
- The reproduction of the population in the region is realized at a normal rate, but it is not uniformly expressed over the territory.
- Settlement systems with a spatial structure with a pointed center and periphery are dominant.
- There is well-constructed housing in good condition and good public service funds, but urbanization should be further developed.
- The population tends to stability in cities and villages which favors the utilization of all settlements in the region.





PART II

SYSTEMS OF MODELS FOR  
REGIONAL DEVELOPMENT



A POSSIBLE METHODOLOGY FOR AN  
ECONOMIC GROWTH ANALYSIS (OF  
THE SILISTRA REGION)

Murat Albegov

Case studies such as the one of the Silistra region are only part of IIASA's research on regional development. Equally important is work done on formulating general methodologies to analyze regional problems and on developing consistent systems of mathematical models to aid in this analysis. An inherent problem of regional modeling lies in the choice that must be made between oversophistication and oversimplification of the problem description. This choice relates to the practicality of the final model. The purpose of the work in the Silistra region was to develop operational models that could be used to formulate practical recommendations for future policy decisions.

PROBLEMS OF THE SILISTRA REGION

A preliminary list of objectives for the Silistra region consists of:

1. Maximizing regional agricultural production.  
This should involve not only maximizing grain and meat production, for which the area is particularly well suited, but also increasing the production of local crops (apricots, grapes and vegetables).

2. Developing an irrigation system that helps local agriculture to achieve optimal production efficiency.
3. Developing local industry that complements local agriculture. This should include the development of some branches of industry that have the potential for growth in the region and helps balance the demand and supply of the labor force.
4. Maximizing the productive use of labor resources in local agriculture, thereby restricting rural-urban migration.
5. Developing a system of settlements and public services. Above all, the plan should make full use of the existing stock of dwellings in the rural areas; it would also involve improvements in the road network, the health care system, etc.
6. Developing local agriculture and industry such that no serious environmental problems result, and creating a recreational area in the region.

Of these 6 objectives, the following three are of primary importance:

- Maximizing agricultural production. This requires the construction of an irrigation system.
- Restricting rural-urban migration.
- Improving the public service system both qualitatively and quantitatively to help achieve the first two goals.

#### STARTING POINT OF THE ANALYSIS

There are two possible approaches to the analysis of regional problems: the "top-down" and the "bottom-up" approaches. These two methods correspond to two different

sequences of economic analysis. The first is based on the assumption that national and interregional problems must be considered first, before planning any regional tasks. The second is based on an "internal" viewpoint. This assumes that plans for regional economic growth can be based primarily on regional factors (i.e. available resources, regional demand and so on) with only minimal use of external information. Both approaches, however, require a two-way information flow between the regional and national levels. This helps assume a consistently interactive planning procedure.

*"Top-Down" Approach*

One of the first systems of models for analyzing future regional growth in a planned economy was developed in Siberia [1]. It was comprised of the following components:

- a. An intersectoral dynamics model for the country as a whole.
- b. An interregional-intersectoral optimization model.
- c. Optimization models for planning program complexes and branches of industry.
- d. Regional optimization models.

The main task of the interregional-intersectoral model in this scheme is to determine the optimal proportion of growth between regions. This gives a general idea about the future role that each region will play in the total national production, employment, etc. Since this model has been published in English, it is not necessary to describe in here [2].

The kind of data obtained from the interregional-intersectoral model is suited for a general analysis of interregional development. However, a regional analysis requires more detailed data on those sectors of the economy in which growth is expected. Therefore, more detailed sectoral models are often needed for the analysis of future regional growth. One such model was developed by the Council of the Location of Production Forces (CLPF [3]). The main points of this model are:

1. All sectors of the economy are divided into two groups:
  - (i) those sectors for which product substitution and product transport are important problems; and
  - (ii) all other sectors.
2. The sectors in the second category can be included in the model directly. Those in the first category, however, require an intermediate step. Special calculations need to be done to determine the optimal location of sector enterprises in that region. In addition, special consideration needs to be given to the next most attractive alternative locations. The purpose here is to obtain a "change of objective" function which expresses the implications of production change in a particular region. For example, this reaction function determines the sectoral gain or loss that results from a given enterprise location in the given region.
3. The marginal costs of resources are frequently used in this model. This assumes, of course, that various complicated problems have already been solved (the optimization of a country's energy balance, for example). It is necessary to include the stability of marginal costs of resources directly in the objective functions without additional constraints.

The task of determining a better allocation of future growth among regions can be formulated as follows:

A. Predetermined and Known Parameters

- (i) future demand for each kind of production in each region and the country as a whole;
- (ii) current level of regional production;
- (iii) possible location of each type of industry and expected capacities of that industry;
- (iv) technical and economic information on each sector's input, output, costs, etc. including those factors influenced by location, i.e. prices

- (iv) technical and economic information on each sector's input, output, costs, etc., including those factors influenced by locations, i.e. prices, (marginal costs) of land, water, power, etc., and
- (v) constraints on the use of resources in each region.

B. Parameters to be Derived

- (i) The structure and location of regional production and the resources required for that production, with the goal of minimized expenditures for production and transportation.

The linear programming problem can thus be expressed as:

Interregional-Intersectoral Problem:

$$\sum_m \sum_{n=1}^{N^1} \Delta F_{mn} X_{mn} + \sum_m \sum_{n=N+1} (C_{mn} + T_{mn}) X_{mn} \quad (1)$$

$$+ \sum_{m,K,l} z_{ml}^K \cdot r_{ml}^K \rightarrow \min \quad (1)$$

subject to

$$\sum_m X_{mn} = \beta_n \quad , \quad (2)$$

$$0 \leq r_{ml}^K \leq R_{ml}^k \quad , \quad (3)$$

$$\sum_n \sigma_{mn}^K X_{mn} \leq \sum_l R_{ml}^K \quad , \quad (4)$$

$$0 \leq X_{mn} \leq A_{mn} \quad , \quad (5)$$

where:

$m$  = regions;  $n$  = sectors;  $K$  = kind of resources;

$A_m$  = vector of maximum available output;

$\beta$  = vector of consumption for the country as a whole;

$\sigma_m^K$  = vector of consumption of resources (per unit of production);

$R_m$  = vector of maximum available resources;

$l$  = a number of plots which linearize the function  $Z(r)$ ;

$Z_{ml}^K$  = cost of unit of resource (restricted by  $R_{ml}^K$ );

$\Delta F_{mn}^K$  = average increase of sectoral expenditures in the case of changing production of commodity  $n$  in region  $m$ ;

$C_{mn}$  = cost of production;

$T_{mn}$  = location rent;

$N^1$  = number of sectors which are needed in the special modeling of their growth and location;

$N^1, \dots, N$  = number of other sectors;

$X_{mn}$  = variable, which shows production of commodity  $n$  in region  $m$ ; and

$r_{ml}^k$  = variable, which shows utilization in region  $m$  of resource  $K$  with the cost related to plot  $l$ .

This model has successfully been run using data from over 100 sectors and 50 regions. In other words, there are no real practical limitations in the use of this model.

#### *"Bottom-Up" Approach*

Though the logic of the "top-down" approach seems to be very clear and attractive, its practical implementation has not advanced very much. Therefore, planners at the local level have a choice. They can wait for some important initial data from the "top" regarding the volume of production, number of employees, etc. Or, they can develop their own approach based on an "internal" view of the problem, while still considering some general external information (the price system for certain commodities, for example).



If the "bottom-up" approach is to be chosen, a further description will have to be done. It should be mentioned, however, that most of the proposed models produce the same results regardless of which approach was taken at the beginning of the analysis.

#### OVERVIEW OF THE SYSTEM OF MODELS

The system of models used to analyze regional problems in a planned economy country is outlined below. This system is designed to meet the following requirements:

- a. It is detailed enough to prepare meaningful options for decision makers.
- b. It should include all the main sectors of the regional economy.
- c. It can be used to calculate variations in regional growth under different external conditions, and can therefore assess the consequences of a change in governmental local policy.
- d. It is flexible enough to adapt to alterations in model structure and changing external information.
- e. It relies on a minimal amount of external information for formulating a regional development plan.

The final point is relevant to the planning sequence used. One could, for instance, (1) wait for the centrally made development plan for the given region, or (2) formulate a few better versions and leave until later the coordination of the local (regional) plan with plans for economic growth of the other regions and the country as a whole. The scheme proposed here is based on the latter approach.

The system of regional models is shown in Figure 1. It can be divided into the following four levels:

PRELIMINARY SCHEME OF THE IRD STUDY

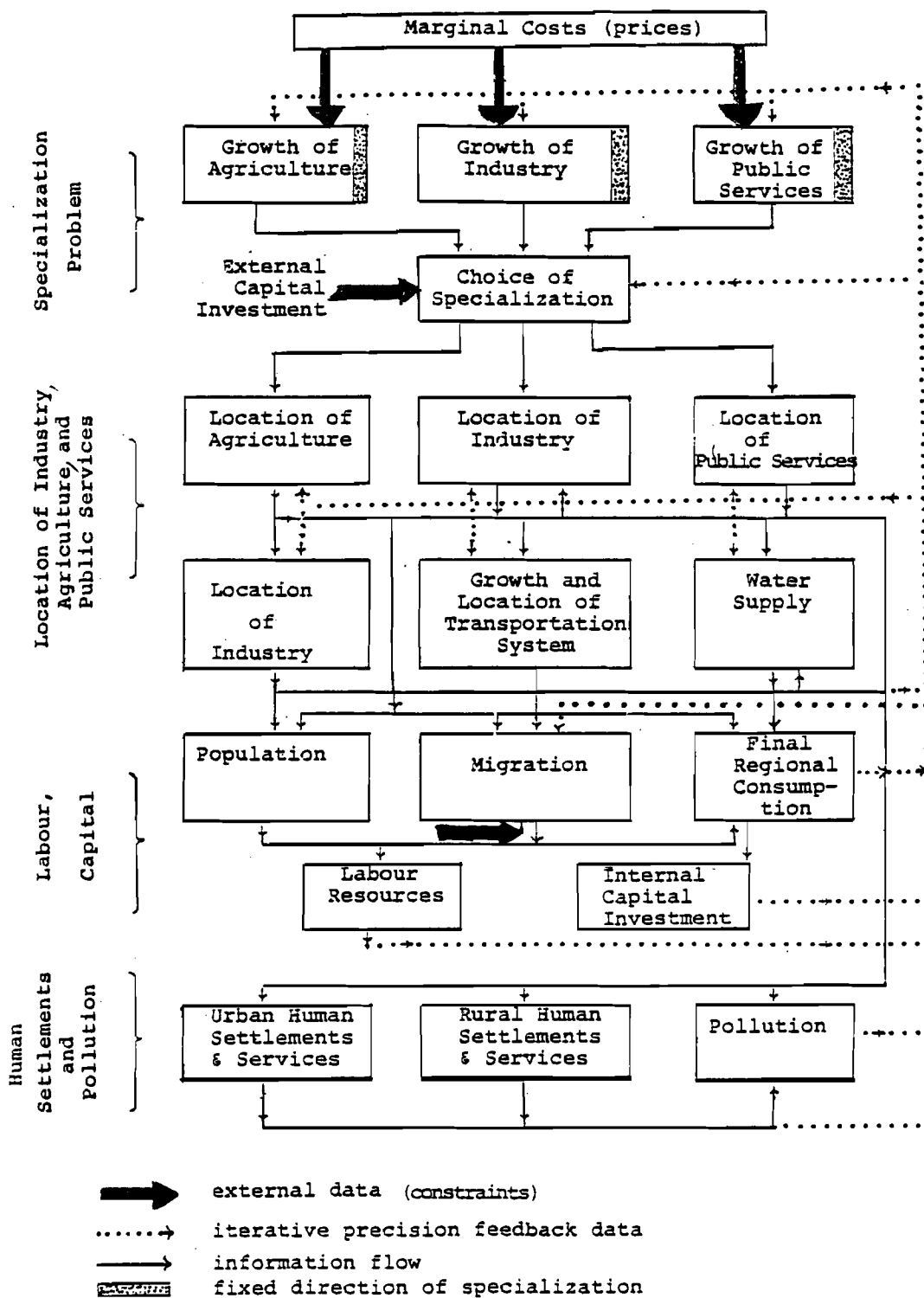

Figure 1. The system of regional models.

- Level I: Choice of specialization.
- Level II: Intraregional location problems.
- Level III: Labor and financial balance problems.
- Level IV: Problems of human settlements, services and pollution.

The general logic behind this sequence is based on the following. On the first level, the region is considered as a whole, and a rough choice of its specialization under average conditions, without intraregional specifics, can be made. In the second stage, the region is divided into 30-40 subregions with specific and disaggregated data concerning water and energy supply, quality and price of land, and so on. This leads to a more precise consideration of intraregional characteristics and, by aggregation, better data for the region as a whole can be obtained. If one is to use these data for the second round of calculation of the task at Level I, (specialization of the region as a whole) one should coordinate the problems of the first two levels.

In addition to the specific problems of each submodel, the main task of Levels III and IV consists of estimates of population size. This reflects the given rates of sectoral activities and takes into account such data as: the level

- the level of salaries and wages of the local employees in comparison with the national ones;
- the level of satisfaction in housing, services, etc., compared with national levels; and
- air and water pollution levels in the region under analysis.

The regional labor force can be calculated relatively easily once the regional population size is known.

The coordination between the first two levels (I and II) and the second two levels (III and IV) is essentially coordination of the estimated level of future regional economic growth and the size of the labor force. If one of the objectives for regional development is to maintain a given employment level,

then the models in Level I and II should, of course, be seen using this value as a constraint. If the region has not constraint on the labor force, then the rate of in- and out-migration should be calculated and the reasons behind this migration should be determined. The efficiency of the specialized sectors in a given region is the principal determinant of the total number of employees needed.

After this general description, it is necessary to describe the separate levels in detail.

### Level I - Choice of Specialization

The purpose of this level of analysis is to generate preliminary data indicating which particular sectors of the regional economy should be developed in order to achieve maximum efficiency. At this stage, the region is analyzed as a whole. That is, the analysis does not reflect any intraregional characteristics.

#### *Sequence of Analysis*

There are two general stages of analyses in Level I. The first step considers various development strategies for each sector, and seeks to maximize benefits, subject to some constraints. These constraints on labor, capital, water, etc. are not to be distributed on an a priori basis between the sectors, and each sector can have a claim on the full amount of resources. It is the second stage of analysis that seeks to coordinate the development strategies of each sector, and finally, indicates the best sectors for future regional specialization.

#### *Information Needed*

The following information must be provided before the models are run:

1. A decision must be made concerning which pricing system will be used. This system is needed to estimate both the benefits resulting from local production and the losses due to expenditures on imports.

2. A list needs to be drawn up of possible commodities that may be produced, given environmental and economic restrictions (water and air pollution guidelines, the availability of labor resources, etc.).
3. Technical and economic data on each regional enterprise needs to be collected, e.g. capital investments required, and the amount of raw materials, energy and water consumed, per unit produced.
4. Constraints on further regional growth, such as limited internal resources and capital investments, should be known in advance. Relevant economic factors (costs of land, energy and water, for example) should also be determined.

#### *Choice of the Pricing System*

Choice of a pricing system plays a central role in this analysis because it can so strongly effect the final results. There are 4 basic methods used to set prices that are applicable to this analysis:

1. Internal (state) pricing.
2. International system.
3. A mixed system (includes 1 and 2).
4. A pricing system that includes penalizing (for example, for imports from other countries).

There is usually a substantial difference between the prices set in an internal system and those set internationally. The choice of which system to use thus affects the additional profitability or losses involved in the production of a given commodity.

One of the problems here concerns setting price levels that are compatible for both industrial and agricultural commodities. The principle of achieving the lowest rate of profitability for the marginal producer seems to be applicable here.

Another problem concerns the difficulties of using the market clearing price mechanism for the service sector in a planned economy country. In many planned economy countries, government policy ensures very low prices for services. It would be inappropriate to use these deliberately low prices as a basis for planning the growth of regional services.

Therefore, a studied price mechanism should also be used if the service sector is market oriented, e.g. oriented toward attracting foreign tourists or to acquiring an exchangeable currency (demand for services from the local population can be determined on the basis of special separate calculations). It should be emphasized that some portion of the planned development of the service sector (and other sectors) can be regarded as being fixed. Consequently, resources can be pre-allocated to meet this requirement.

Another consideration is the extent to which prices will change in the future. Two possible methods to determining this change are to:

1. use existing prices for which detailed information is available; and
3. use the results of equilibrium or optimization models (for example, aggregate input-output balance models).

In the first case, the relative price change of important commodities can be accounted for by adjustments in the cost components of each commodity. For example, the price for energy can be introduced by increasing the energy cost-component in the price of a commodity and so on.

The attractive aspect of the second method is that it yields a more homogeneous pricing system. At the same time, of course, this makes it necessary to transform aggregate prices into unit prices for a particular commodity.

None of these pricing systems reflects interregional diversification costs, however. An approximate measure can be obtained using mid-year transportation cost estimates for the period under analysis.

In the Silistra region where production of export commodities is important for future regional growth, the following approaches can be recommended:

1. Use of a mixed (stage-international) system to set prices with penalties for foreign purchasing. International prices should stimulate expansion of production for export; the penalty system will restrict unnecessary purchasing from abroad.
2. The development of the regional service sector should be fixed in advanced.
3. Mid-year transportation cost-estimates should be used in the calculations to reflect the cost of interregional diversification.

#### *List of Possible Commodities for Production*

A list of possible regional products needs to be drawn up. This list should consist of all commodities that could feasibly be produced in the region, given environmental, demographic and economic constraints. These factors must be kept in mind:

1. The list needs to be exhaustive.
2. The possibility that the industrial and agricultural sectors share relatively independent subsectors should be thoroughly analyzed.

The first point allows regional planners to consider all possible development strategies. The second point is essential for the proper formulation of a sectoral model. All interdependent sectors need to be analyzed as a single unit, and the overall effect of such interlinked sectors should then be considered.

#### *Technical and Economic Characteristics of Regional Enterprises*

Statistics on the basic technological and economic requirements for each enterprise, such as its consumption of energy, water or raw materials, are, of course, essential for regional planning. The point to be made is that these statistics should

describe regional enterprises as they will exist in the future. This means that average measurements, or coefficients obtained from a basic input-output balance are not sufficient. Rather, data which reflect technological advance should be used in the calculations.

#### *Constraints on Further Economic Growth*

Constraints on regional growth are capital investments, labor, energy, some raw materials, land, water, and air pollution, etc. In this stage of analysis, such limitations apply to the region as a whole. Corresponding economic data, for example, cost of land, water, etc., can also be averages for the region as a whole.

#### *Useful Models*

Two different types of sectoral models should be used in Level I:

1. The first type is needed to describe the activities of each sector within the region under analysis.
2. The second is used to coordinate the development strategies of each sector.

The complexity of the first type of model depends largely on the number of sectors involved. The one-sector case is a continuous-time one-product problem with linear constraints and usually a non-linear objective function. If the objective function is convex it can be solved by using a linear programming approach. In the case of interdependence between many sectors, the problem is more complicated, due to the additional number of constraints involved.

In both cases, the purpose of running the sectoral models is to obtain an "efficiency function." This function expresses the effect that use of important limited resources has on the development of each sector or group of sectors. In the Silistra region, labor and capital can be considered as important limited resources.



If the effect of resource use on sectoral growth is known, then:

$$\sum_i E_i(C_i, L_i) \rightarrow \max, \quad (6)$$

subject to

$$\sum_i C_i \leq L_E, \quad (7)$$

$$\sum_i L_i \leq L_E, \quad (8)$$

$$0 \leq L_i^{\min} \leq L_i \leq L_i^{\max}, \quad (9)$$

$$0 \leq C_i^{\min} \leq C_i \leq C_i^{\max}, \quad (10)$$

where:

- $i$  = index of a sector or group of sectors;
- $E_i$  = efficiency function;
- $L_i$  = number of employees in sector  $i$ ;
- $C_i$  = capital investments into sector  $i$ .

It is statements (6)-(10) that are used to determine the optimal sectors for future regional specialization.

## Level II - Intraregional Location Problems

### *Goals*

The goals for this level of analysis are to check the ability of the region to carry out the sectoral development program decided upon in the first level, and to determine the optimal location of new enterprises. No longer is the region viewed as a single unit. This second objective requires that the region be divided into several subregions. In this way, the particular features of each subregion may be considered separately.

### *Sequence of Analysis*

There is a definite sequence of analysis that seems to be the most efficient for determining the optimal location of regional enterprises. It is best to consider the public service sector first. Recreational areas, tourist facilities, etc. usually need to be located in special or even unique areas, so that land for this purpose should be allocated first. After public services, it is most convenient to deal with agriculture and primary industry for which location is not interdependent with secondary and tertiary branches of industry.

The third step is to allocate branches of secondary and tertiary industries among subregions. This step consists of determining the optimal location of many sectors simultaneously. Marginal costs of land and some raw materials can be used in these calculations.

Completion of the third step leads to the consideration of an analysis of such "auxiliary" sectors as the construction industry, the intraregional transportation network (intra-regional) and the water supply system. Growth and location of the "auxiliary" sectors is completely determined by the location of other sectors. Although the agricultural and industrial sectors are the main determinants, interaction with other sectors also exists. Growth of a settlement system, for example, can influence the size and location of water supply facilities.

### *Information Needed*

The data necessary for this level of analysis is available from three sources: data already generated in Level I, internal information, and data from Level IV.

Level I provides data on the growth of each sector of specialization for the region as a whole. The internal information needed includes subregional costs of land, water, energy, raw materials, costs of construction, transportation and so on. Level IV, which deals with human settlements, provides information on population growth and settlement patterns, and the

corresponding demand for water, energy, and transportation facilities. Data from Level IV can also be used to curtail water and air pollution, and restrict overconcentration of sector enterprises. On the first iteration of calculations this information can simply be preliminary estimates from experts. On the following interactions, of course, the data are obtained by running the model.

### *Useful Models*

The models on this level of analysis generate detailed information on the conditions affecting enterprise location. Such a detailed analysis can lead to a very large problem description, making it impractical in many cases (agriculture, for example) to include time directly in the model. Therefore emphasis should be placed further on intraregional problems taking into account that dynamics can be considered with the help of a time-slice. Such a slice can be made regularly for each five-year period, and for each year using the initial part of the period under consideration.

Modeling the intraregional location of activities requires that the characteristics of particular sectors be taken into consideration. For example:

1. Is it a one-product or many-product sector?
2. Is there a substitute for the final product?
3. Does the problem have a discrete solution?
4. Is transportation a significant problem for the the given sector, and so on.

For the agricultural sector, which consists of many interdependent subsectors (for example, crop and livestock production) it is necessary to analyze all sectors involving land use within one model (e.g. grain cultivation, industrial crops, starchy root crops, vegetables, garden crops, and livestock as a consumer of fodder). This model is not shown here because of space considerations [4]. Suffice it to say that is a linear programming model; and, for an example case of 30 subregions, it uses 30 crops, 2 farm types and consists of 3700 rows of about 8000 variables (Figure 2).

Number of (non) Equation	Character of (non) Equation	V A R I A B L E S										C O N S T R A I N T S			Number of Rows (Tentative)			
		P l a n t s			L i v e s t o c k		E x t e r n a l P u r c h a s i n g		U s e o f H a y M o w i n g									
		$X_{iprs}$ <sub>1</sub>	$X_{iprs}$ <sub>2</sub>	$X_{iprs}$ <sub>3</sub>	$X_{iprs}$ <sub>4</sub>	$X_{iprs}$ <sub>5</sub>	$X_{ijkpr}$ <sub>6</sub>	$X_{ijkpr}$ <sub>7</sub>	$X_{ijkpr}$ <sub>8</sub>	$Q_{ijk}$ <sub>9</sub>	$Q_{ijk}$ <sub>10</sub>	$Z_{jkmpr}$ <sub>11</sub>	Lowest	Highest	Equity			
0	I. Sub-regional level	-----																
1	Land use	1																
2	"	1																
3	Use of Pastures		1									1						
4	Forage Balance	1					1	1					0					
5	"	1					1	1					0					
6	"	1					1	1					0					
7	"	1					1	1					0					
8	Crop-Rotation	1											$L_{ipr}^{min}$				$L_{ipr}^{max}$	
9	Livestock Production	1											$M_{jpr}^{min}$				$M_{jpr}^{max}$	
10	Second crop Production	1				1							0					
11	Capital Investment	1				1	1											$C_{pr}^{ext} + C_{pr}$
12	Labor Resources	1				1	1	1										$B_{pr}$
13	Use of Water	1				1	1											$D_{pr}$
14	Use of Machinery	1				1	1											$E_{pr}$
15	Use of Fertilizers	1				1	1	1										$G_{fpr}$

Figure 2. Constraints matrix structure.

Number of (non) Equations	Character of (non) Equations	VARIABLES											CONSTRAINTS			Number of Rows (Tentative)			
		Plants				Livestock		External Purchasing			Use of Hay Mowing	12	13	14					
		$X_{ipr}$	$X_{iprs}$	$Y_{ipr}$	$Y_{iprs}$	$X_{jkpr}$	$Y_{jkpr}$	$Q_{ijkpr}$	$Q_{ijk}$	$Z_{jkpr}$									
16	II. Regional Level	1	1	1	1														
17	Crop consumption	1	1	1	1														
18	"	1	1	1	1														
19	Meat consumption	1	1	1	1														
20	Meat production	1	1	1	1														
21	Forage Purchasing	1	1	1	1														
22	Crop Purchasing	1	1	1	1														
23	Meat Purchasing	1	1	1	1														
24	Labor limit	1	1	1	1														
25	Machinery Limit	1	1	1	1														
26	Fertilizer Limit	1	1	1	1														
27	Water limit	1	1	1	1														
28	Partial Capital Limit	1	1	1	1														

Figure 2. (continued) Constraints matrix structure.

The basic problem here is how to coordinate this agricultural model with the other sectoral models. The procedure described in equations (6)-(10) can again be implemented: agricultural efficiency as a function of capital investment and the number of employees needs to be determined. This requires a special series of calculations in which labor and capital investment vary in a complete series of permissible changes.

Industrial sectors need to be divided into two categories. The first category includes those sectors in which product or technological substitution is an important problem, and the sectors for which transportation costs can strongly influence enterprise location. The second category simply consists of all those industrial sectors not included in the first.

The second category can be included in the final model directly because its activities can be described relatively easily. The first category, however, requires an intermediate step. This involves a preliminary run of the intraregional location model to determine not only the optimal location for these industrial enterprises, but also the next most attractive alternative locations. The idea here is to formulate a special "displacement cost" function. This function is a measure of the increase in sectoral expenditures when the enterprises of that sector are not optimally located. It can provide a basis for making final location decisions when all sectors are considered simultaneously. Example calculations are shown in Figure 3.

Thus, the integer problem of intraregional location of industrial sectors can be formulated in terms of the minimization of an objective function, F:

$$F = \sum_m [\sum_n f_{mn}(y_{mn}) + \sum_k \varphi_m^K (R_m^K) - S_m(\bar{Y}_m^K)] \rightarrow \min, \quad (11)$$

subject to

$$0 \leq Y_{mn}^K \leq R_{mn}^K, \quad (\text{for all } m, n, k), \quad (12)$$

Calculation of  $\Delta F_{mn}$

$$F = \sum_j [ L_j (X_j) X_j + \sum_j (W_{ij} + S_j) Y_{ij} ] \rightarrow \min \quad (1)$$

subject to:

$$\sum_j Y_{ij} = X_i A_i \quad (i = 1, 2, r, m) \quad \text{where } r \text{ is the point under} \quad (2)$$

$$(j = 1, 2, \dots, n) \text{ consideration}$$

$$\sum_i \beta_{ij} Y_{ij} = \beta_j \quad (3) \quad X_i, Y_{ij} \geq 0 \quad (4)$$

where  $X_i$  dimension of production in point  $i$  and  $\bar{X}^0 = (X_1^0, X_2, \dots, X_r^0, \dots, X_n^0)$  and  $F^0$  correspond to the optimal solution, then one must calculate  $F^*$  for  $X_r = 0, 0,1A_2, 0,2A_2, \dots, A_2$  and  $Y = F^* - F^0$

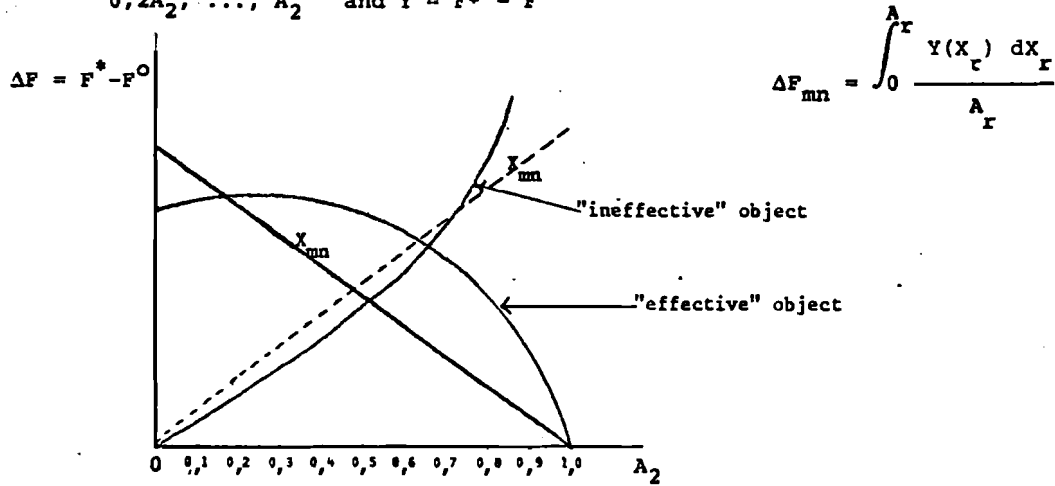

Figure 3. Calculation of objective function coefficients.

$$Y_{mn}^K = \sigma_{mn}^K \cdot Z_{mn} \cdot A_{mn} \quad , \quad (\text{for all } m, n, k) \quad , \quad (13)$$

$$\sum_n Y_{mn}^K = R_m^K \quad , \quad (\text{for all } m, n, k) \quad , \quad (14)$$

$$\sum_m Z_{mn} A_{mn} = B_n \quad , \quad (\text{for all } n) \quad , \quad (15)$$

$$Z_{mn} = \begin{Bmatrix} 0 \\ 1 \end{Bmatrix} \quad , \quad (\text{for all } m, n) \quad (16)$$

where:

- $m$  = location;  $n$  = sectors;  $K$  = resources;
- $\bar{A}_m$  = vector of maximum production capacities;
- $\bar{R}_m^K$  = vector of consumption of resource  $K$  in point  $m$  which corresponds to  $\bar{A}_m$ ;
- $\bar{B}$  = vector of outputs of the region under consideration;
- $\bar{\sigma}_m^K$  = vector of technological coefficient of input;
- $R_m^K$  = total consumption of resource  $K$  in location  $m$ ;
- $f_{mn}(Y_{mn})$  = variation of expenditures of sector  $n$  as a function of the size of production (or resources used) in location  $m$ ;
- $\varphi_m^K(R_m^K)$  = cost of resource  $K$  as a function of the size of consumption in location  $m$ ;
- $S_m(\bar{Y}_m^K)$  = agglomeration economy in the case of joint construction and exploitation of enterprises in point  $m$ , as a function of the amount of consumption of resource  $K$  in location  $m$ ;
- $\bar{Y}_m^K$  = vector of optimal allocation of resource  $K$ ;
- $\bar{Z}_m$  = vector of intensity of use of maximum capacity  $\bar{A}_m$ .



In problems (11)-(16) economies of scale are expressed as a function of size of the resources used and their distribution among the enterprises of location  $m$ . Within the separate locations, economies of scale,  $S$ , can be expressed as a function of total capital investments, number of employees (wage expenditures), and the amount of land needed for the jointly located enterprises:

$$S = \alpha \cdot K^{\beta} \cdot L^{\sigma} \cdot T^{\delta} , \quad (17)$$

where:

$\alpha, \beta, \sigma, \delta =$  constants;

$K =$  total capital investments;

$L =$  total wage expenditures;

$T =$  amount of land required.

Although it results in some loss of accuracy, economies of scale can also be expressed as a function of a single variable--the consumption of a particular resource (water, for example).

Diseconomy of scale can also be included in equations (11)-(16), although it would be a function of variables other than those in (17). Diseconomy of scale would depend instead on such varied factors as congestion, pollution, etc.

#### *Other Sectors of the Economy*

Other sectors of the economy include the construction industry and the transportation and water supply systems. The allocation of the construction industry should correspond to the location of the centers of new activities.

Choosing the best way to develop a comprehensive transportation network is a much more difficult problem. Special models need to be implemented here [5].

Estimates of regional growth and the planned location of new activities provide a good basis for estimating future water demand and developing a water supply model. Calculation of total water demand is fairly straightforward, since most of the demand is fixed and the rest is population-related.

The problem here lies in elaborating a water-supply model detailed enough to provide necessary information about the availability of resources and water costs for different sub-regions during different times of the year. Work on this problem has already been done at IIASA [6].

### Level III - Labor and Financial Balance Problems

#### *Goals*

The main objectives at this level are to achieve a balance between the regional employment level and the regional labor force, and to estimate the ratio of income to expenditures of the local population.

#### *Sequence of Analysis*

Regional migration models play a central role at this level of analysis because they provide data necessary for estimating regional population growth and, especially, for calculating regional labor resources.

The ratio of income to expenditures is needed to help estimate internal capital investments for further regional growth. And, because migration rates depend to a great extent on the income differentials between regions, data on local income can also be used to improve the accuracy of regional migration models.

Given these considerations, the following sequence of calculations can tentatively be suggested:

1. Begin by estimating the income-expenditure ratio.
2. Run the regional migration model.
3. Run the regional population model using information from steps 1 and 2.
4. Use the results of these calculations as a basis for estimating the regional labor force.

### *Information Needed*

The following information, obtained from previous levels of analysis, is needed for calculations of this level:

1. All the data concerning the growth of sectors of regional specialization. These data were obtained from Levels I and II.
2. All the data concerning the growth of tertiary industry. These data were used tentatively in the first iteration in Level II and become more and more precise from iteration to iteration.

The following information needs to be used from Level IV of the analysis:

1. Data measuring the level of satisfaction with housing and services in the region.
2. Data concerning the standard of living in the region. This information can be used in the migration model and can influence the rate of in- and out-migration.

Finally, some additional information should be prepared especially for this stage of analysis:

1. Data on the past birth and death rates and rates of in- and out-migration in the region.
2. The results of the survey into the budgets of different groups in the population.

### *Useful Models*

An approach developed by A. Rogers [7] can be used to calculate regional population growth. This method, however, considers fixed migration rates, and should be modified to include variable rates. Variable migration rates can be expressed as a function of the standard of living, and regional economic growth and its efficiency.

To calculate future regional migration, a special model developed by A. La Bella [8] may be used. In this approach, the propensity to migrate,  $q_{ij}^*$ , can be expressed as a function of the current and estimated future differentials between region i and region j:

$$q_{ij}^x = q(x; \Delta R_{ij}, \Delta C_{ij}, \Delta h_{ij}^R, \Delta h_{ij}^C, r, L_x, \gamma_{ij}) \quad ,$$

where:

- $\Delta R_{ij}, \Delta C_{ij}$  = current differentials in benefits and costs;
- $\Delta h_{ij}^R, \Delta h_{ij}^C$  = expected differentials in rates of growth of income and cost of living;
- $x$  = age group;
- $r$  = discount factor;
- $L_x$  = indicator of differential situation of local labor markets;
- $\gamma_{ij}$  = fixed cost of the move.

From this basic equation, several different models can be derived, including some with dynamic and stochastic aspects, at varying levels of sophistication and simplicity of implementation. In the first test run of this model, two simplified versions of the aggregate propensity to migrate were used. The first one is linear, and the second one is a constant-elasticity function [8].

Estimates of the regional labor force can be easily calculated using regional census data stratified by age groups. In turn, the labor force estimate and other demographic data can aid in estimates of the income-expenditure ratio.

Level IV - Problems of Human Settlements, Services, and  
Pollution

*Goals*

The goals of this level are not only to find the best way to deal with the problems related to human settlements, services and pollution, but also to supply important information for the migration model in Level III. This information can be used in analyses regarding how the standard of living and the quality of life influence regional migration.

*Sequence of Analysis*

Depending on the information received from Levels I and II on rural and urban population, all three main topics in this level can be analyzed separately. There is some interaction between these problems, however. For example, the results of running the water and air pollution models can show that a given urban concentration is impermissible. In that case, some restrictions on urban concentration would need to be taken into consideration. Likewise, a municipal system of services can also be used by adjacent rural areas. A convenient sequence of analysis would be: rural settlements, urban settlements, urban service system, rural service system (if not covered previously), regional water pollution, and regional air pollution.

*Information Needed*

Much of the information needed for this final stage of analysis has already been generated in the first three levels:

1. Data about the location of the main industrial sectors. This information should start from the point where industrial growth is first estimated.
2. Projections of regional population growth, by age group. This information can be used to plan the growth of educational centers, recreation areas, and so on.

3. Data about the growth of the different enterprises in the region. This can be the basis for water and air pollution estimates.

Additional information needed here consists of the characteristics of the present settlement system, the public service system, and the quality of life in the urban and rural areas.

#### *Useful Model*

The final choice of the best model of human settlements will be done jointly with representatives of IIASA's Human Settlements and Services Area. A multi-objective optimization approach for analyzing urban and rural settlements currently seems to be the most promising. The same approach can be used for the analysis of infrastructure problems.

There are two principle model types for analyzing water and air pollution problems: models of physical processes (diffusion of pollutants) and pollution quality management models. The latter is more important. The water quality management model can use either linear programming [9], or discrete dynamic programming [10].

Results of the water quality model should be compared with the results of the water supply model, because water dilutants can be used as one of the ways to satisfy water pollution constraints. Marginal costs in both models need to be equal.

#### INITIAL STAGE OF WORK

The completion of the entire model system shown in Figure 1 requires a long time. However, practical results are needed in a relatively short time. If one agrees that the main problems of the Silistra region are agricultural growth, and migration, then the following simplified version of the system of models can be proposed as a first stage of investigation (Figure 4).

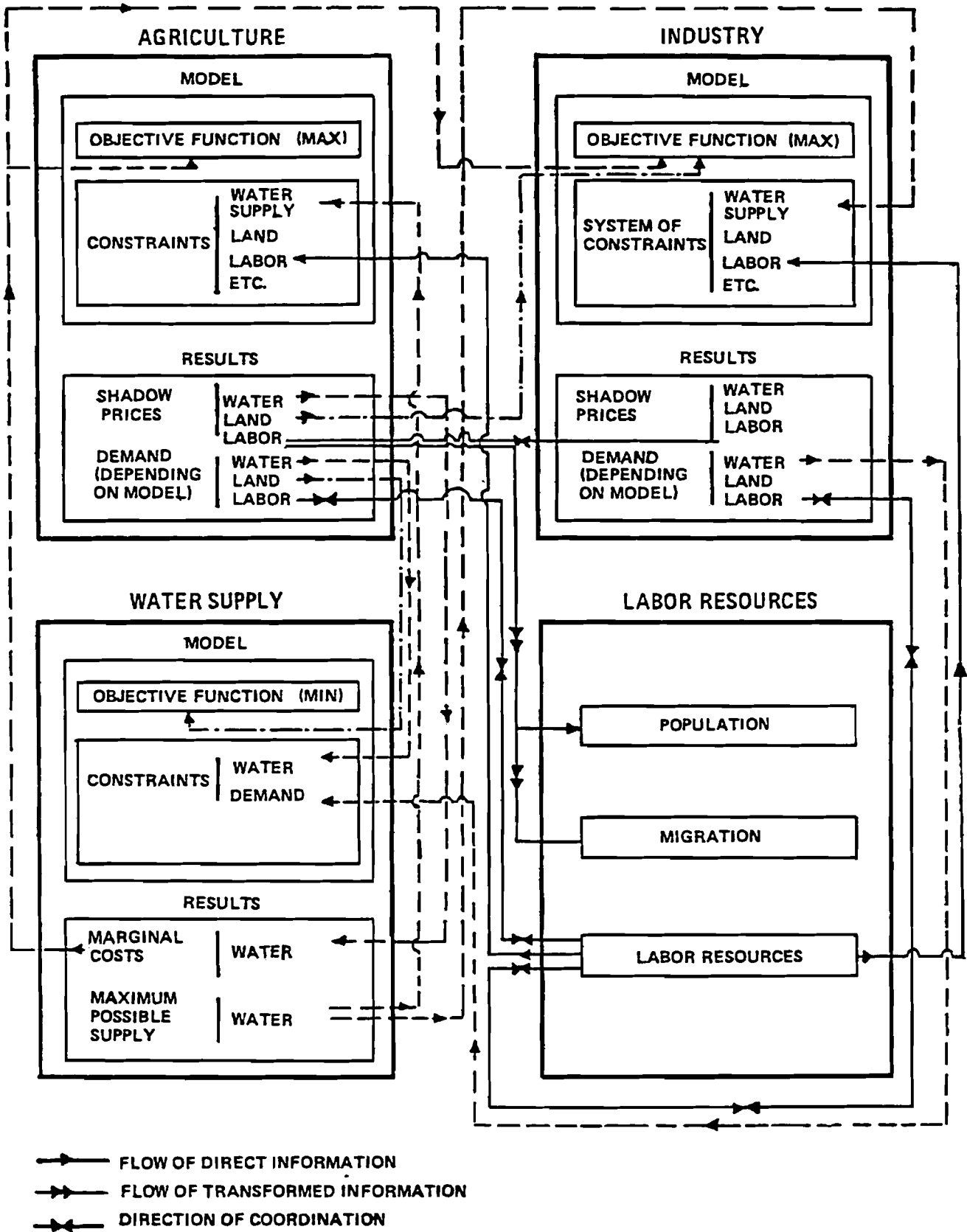

Figure 4. Simplified system of models.

This simplified version of the full system of models consists of only five models:

- a regional agricultural model;
- a regional industrial model;
- a regional water supply model;
- a regional labor resource model; and
- a coordinating model.

All of them are taken from the first three levels of the original scheme. All these models are close to completion.

The generalized regional agricultural model (GRAM) has been written in draft form and will appear as an official publication at IIASA [4] and is now in the process of being equipped with auxiliary sub-programs. The pilot version of this model for the country as a whole in an actual situation in the USSR.

A number of different types of growth and location models currently exist. Among them, there are discrete and continuous models, some involving both production and some involving production alone. These models can use either a matrix or a network approach, involving one stage or many stages and use deterministic or stochastic variables [11]. Enough work has already been done that sectoral analysis should pose no major difficulties. However, as was demonstrated before, the analysis of sectoral models is only the first stage. All sectors must then be considered simultaneously, as shown in (11)-(16).

The water supply model is operational and is broad enough to describe the actual situation in the Silistra region. As was shown earlier two simplified versions of the regional migration model have recently been tested.

The main objective with this simplified model is to coordinate the decisions of the three special diversified models (agriculture, industry, and water supply) with the point model of regional migration. A coordinating model, identical to the one shown in Scheme 1 may be used for this purpose.



### *Information Needed*

The preliminary data needed to run this simplified version are estimates of the direction that regional specialization will take, and estimated regional growth rates. This information is simply the characteristics of the region as a whole.

To complete the cycle of calculations, one needs to have the following information:

- Amount of commodity production by agriculture, and primary and secondary industries in the region as a whole.
- Growth of tertiary sectors of industry in the region as a whole and tentative estimates for each subregion.
- The number of employees, average cost of water, land and other resources for the region as a whole.
- The economic costs locating economic units in various areas in different subregions (cost of construction, of energy, and so on).
- Technical characteristics of the enterprises for all the sectors of the regional economy, i.e., demand for water, energy, labor, capital investment, and so on, per unit of commodity produced.

### *Sequence of Analysis*

The calculations can start with the agricultural model. Before running the agricultural model the first time, one needs to know the prices for commodities, limits on capital investment, and limits on the use of the labor force, water, etc. The results of these calculations should be: the size of production of different commodities, consumption of labor, water, capital investments, etc., and an aggregated function of sectoral efficiency based on the amount of capital investments and labor used.

For a disaggregated function of sectoral efficiency, marginal costs may be used (for example, marginal costs of land for the location of industrial sectors).

After solving the problem of agricultural and industrial location, it is easy to use the regional water supply model. The majority of water demand is known, and the portion determined by the population can be tentatively assigned on the basis of the first iteration. The results of the calculations are limited to marginal costs of the water supply for each subregion, and to average costs for the region as a whole. All these data are to be used on the next iteration to coordinate the solutions of agricultural and industrial models.

The model of regional labor resources is needed to balance the demand and supply of labor resources. The control variables are those factors which influence regional migration (see the description in Level III). By changing such indices as the number of dwellings per capita, or by altering wage levels in the given region and in the rest of the country, one can stimulate an in-flow or out-flow of migrants to balance regional demand and supply of labor.

Finally, the coordinating block uses the results of the four previous models, and yields more precise data about the future growth of regional commodity production.

#### CONSISTENCY PROBLEM ANALYSIS

This system of models is designed primarily to solve the problem of regional specialization, with subsequent analysis of interrelated intraregional problems. There is a problem, though, with the overwhelming number of sectors in the regional economy. The following procedure, using input-output analysis techniques, can be used to check the consistency of the assigned growth of specialized sectors to the growth of other sectors in the region.

Let us assume that for the beginning of the period under consideration, a regional input-output model exists such that:

$$(I - A_t - B_t) X_t = Y_t ,$$

where

- I = diagonal unit matrix;
- $A_t$  = matrix of current demand coefficients for year t;
- $B_t$  = matrix of investment demand coefficients;
- $Y_t$  = vector of final consumption;
- $X_t$  = vector of production of commodities.

Let us assume that vectors of production and final consumption are shared, and  $n = 1, 2, \dots, N^1$  are the sectors of regional specialization;  $n = N^1+1, N^1+2, \dots, N^{11}$  are the commodities; and  $n = N^{11}+1, N^{11}+2, \dots, N^{111}$  are the sectors of tertiary industries whose growth is dependent on the size of the local population and the average level of income. For the year  $t + \tau$ , the problem

$$(E - A_{t+\tau} - B_{t+\tau}) X_{t+\tau} = Y_{t+\tau} ,$$

has only one solution, because for the full number of sectors  $N$  one has to know the following figures:

- for  $n = 1, 2, \dots, N^1$  the figure  $X_{t+\tau}$  = on the basis of regional specialization solution;
- for  $n = N^1+1, N^1+2, \dots, N^{11}$  the figure  $Y_{t+\tau} = 0$  because these sectors produce only intermediate commodities;
- for  $n = N^{11}+1, N^{11}+2, \dots, N^{111}$  the figure  $Y_{t+\tau} \neq 0$ . This can be calculated when the size of population and its average income are known.

The coefficients of matrix A can be calculated for the first  $N^1$  commodities as:

$$a_{t+\tau} = \frac{\beta_{t+\tau} \cdot a_t \cdot \gamma_{t+\tau} \cdot X_t + a_\tau \Delta X_{t+\tau}}{X_{t+\tau}},$$

where:

- $a_t, a_\tau, a_{t+\tau}$  = input coefficients for sector  $n$   
( $n = 1, 2, \dots, N^1$ ) for years  $t, \tau, t+\tau$   
respectively;
- $\beta_{t+\tau}$  = improvement of input coefficients of  
the existing enterprises in the period  
between years  $t$  and  $t+\tau$  (in percent  
share);
- $\gamma_{t+\tau}$  = increase or decrease of commodities  
in the existing enterprises between  
the years  $t$  and  $t+\tau$  (in percent share);
- $\Delta X_{t+\tau}$  = increase or decrease of production of commodities  
in new plants in the period under  
analysis;
- $X_{t+\tau}$  = general production of the commodity  
in the year  $t+\tau$ .

For other sectors forecasts of improvement of the input coefficients can also be used.

#### ASSESSING POLICY OPTIONS

As is clear from previous discussions, the results of all the calculations can be expressed in two ways. The first is in terms of different actions that can be taken (what and how much to produce, where to locate enterprises or housing settlements, who shall benefit from services, etc.). A second way of viewing the results is in terms of the expenditures that correspond to these actions. Thus, governmental or local policy decisions can be assessed on a monetary basis

The central goal can affect regional growth by:

1. The total size of capital investments to the region under analysis.

2. The special regional wage policy designed to regulate regional migration flows.
3. The change ratio between exchangeable currency and local currency to stimulate regional production for export.

Local authorities can influence regional growth by:

1. Redistributing local budgets in favor of housing construction, improvements in service systems, etc.
2. Introducing stringent pollution controls.

All these factors can be included in the model in different ways. They can be included as:

- a. Constraints (as for example, limits on pollution or size of governmental capital investments).
- b. Changeable parameters (as for example, the ratio between hard and local currencies).
- c. Control variables (as for example, a preliminary assignment of low production limits).

#### CONCLUSIONS

The main purpose of the approach proposed here is the use of detailed sectoral models to formulate practical recommendations for decision makers. Special methods for coordinating the different models are also proposed. The scheme outlined here should be considered as a starting point. In the course of its completion, some changes, of course, are possible. In general, however, the approach is very attractive because it is capable of achieving the desired goals.

REFERENCES

- [1] Aganbegyan, A.G., K.A. Bagrinowski and A.G. Granberg (1972) System of Models for National Economy Planning. Moscow.
- [2] Granberg, A.G. (1974) The Construction and Use of Inter-regional Interindustry Models in the USSR. Sixth International Conference on Input-Output Techniques held in Vienna.
- [3] Models of Production Location (1975), Sciences, Moscow.
- [4] Albegov, M. (1979) Generalized Regional Agriculture Model (GRAM): Basic Version. WP-79-00 (forthcoming). Laxenburg, Austria: International Institute for Applied Systems Analysis.
- [5] Koslov, E.T. and V.N. Livshiz (1967) Choice of Rational Scheme of Transport Network Development. Using of Mathematical Methods and Computers in Transport Development Planning. Transport. Moscow.
- [6] Albegov, M. and V. Chernyatin (1978) Water Supply in Regional Model Systems. Paper presented at the II Notec Regional Development Task Force Meeting, in Jablonna, Poland, September 1978.
- [7] Rogers, A. (1975) Introduction to Multi-regional Mathematical Demography. John Wiley and Sons.
- [8] La Bella, A. (1979) Factors Mobility in Regional Development. RR-79-00 (forthcoming). Laxenburg, Austria: International Institute for Applied Systems Analysis.
- [9] Revelle

- [9] Revelle, C., D. Loucks and W. Lynn (1968) Linear Programming Applied to Water Quality Management. Water Resources Research, 4, 1, February.
- [10] Stanishievsky, C. (1974) On Application of Qualified Dynamic Programming to Optimization of Water Protection Measures. Water Protection Problems, 5, (in Russian).
- [11] Basic Principles of Growth and Location of Production, (1969) Moscow-Novosibirsk (in Russian).





A SYSTEM OF MODELS FOR  
INTEGRATED REGIONAL DEVELOPMENT:  
An Application to the Silistra  
Case Study

Ake E. Andersson and  
Agostino La Bella\*

\*With the participation of Andras Por and Tuomo Nenonen



## SCENARIOS IN REGIONAL PLANNING

It is argued in this paper that the creation of different scenarios is a necessary feature of the planning process. Such planning scenarios can be developed verbally and be aided by sketching as is often done in physical planning. However, experience shows that such a procedure is only viable if the number of factors to be planned is extremely small. This implies that computer-assisted planning procedures become more suitable as the number of fundamental dimensions and their disaggregation increases.

The economic structure can be seen as one of the planning dimensions, the regional structure can be looked upon as another dimension and the time structure of activities is a third dimension. If we make the assumption that the economic structure is represented by 30 production sectors, the regional structure is represented by 10 regions, and the time structure by only three periods, the minimal size of a model featuring all interdependencies would be 900 variables. It goes without saying that if a plan is to guide the development of such a system, then it is only possible to construct such a plan with the aid of a formal computer model.

It was often assumed in the early theory of planning that such a big planned system must by necessity have one and only one global goal function to be maximized, subject to certain technological constraints. Analogously, one should make one giant model for the whole system and maximize the global function subject to the possible variations in the variables which can be looked upon as the instruments of planning.

This attitude can be criticized along at least three different lines:

1. It may not be possible to construct an empirically reasonable and yet numerically computable model of a whole economy with spatial, sectoral, and dynamic dimensions.

2. Policy makers may not be willing or able to state their valuations in a form usable for programming purposes before they have a feeling for the general structure of the consequences of their valuations. It is, thus, disputable if valuations can be determined before the planning process. Valuations might have to be learned through the planning process.
3. With a spatial subdivision one has to acknowledge the possibility of regional, sectoral, or even regional-sectoral differences in the opinions on the relative importance of goals for the production sectors and the regions.

The first issue is discussed at some length in section 3 of this paper. One point could, however, be mentioned at this stage in relation to it. Most planning models can be given quite a concrete and statistically reasonable specification when it comes to those constraints which have a clearly technological background. This is the case with the resource use constraints. Most planning models for an economy contain very well-specified constraints on the use of primary materials, labor, and other factors of production. One can also specify the interdependencies between the sectors with some degree of precision. It is, however, rather hard to specify the behavioral constraints which regulate the activities of the households as consumers and other decision makers in the economic system. It is thus probable that a model for the planning of an economy will be insufficient in terms of the specification of behavioral relations. This means that formal constraints on the choice of a planning strategy often cannot take behavioral constraints sufficiently into account. The way out of this dilemma is possibly to generate a large number of alternatives, all technologically feasible, but with different behavioral consequences and let the qualitative analysis of the politicians determine which one of these technologically feasible solutions to the planning problem should be accepted as a basis of implementation.

The second issue above makes the claim that valuations are in fact developing through the planning process. This has also been shown to be true at the psychological level, when people have been involved in decision-making experiments. The implication of this attitude is the one that policymakers should be continuously involved in the use of computerized planning models.

Our suggestion is thus that we should organize a system of models, which would be such that they could highlight essential decision problems at different levels of decision making in the form of scenarios, all consistent within the framework of the different models used in the total planning procedure. These different scenarios could then be used by the Bulgarian planners as an input into their discussions of the policy-making process and possibly lead to a converging set of interesting scenarios.

#### THE GENERAL STRUCTURE OF THE SILISTRA CAST STUDY ACCORDING TO THE FRAMEWORK OF CONSISTENT SCENARIOS

As we have concluded in the preceding section it will not be possible to create one comprehensive model for the whole study of Silistra. It is rather the case that we must design an almost hierarchical set of models successively narrowing down the planning problem. A comprehensive outline of the approach to modeling is given in Figure 1.

#### *International Demand*

The forecast of international demand from non-Bulgarian economies is of extremely great importance for any study at the national or regional level for a country with a dependence on exports as high as Bulgaria's. The importance of international demand must be formulated both in terms of the product involved and in terms of countries of import.

A forecast prepared for the Economic Commission for Europe indicates that the following products will face a stagnating world market in the 1980s:

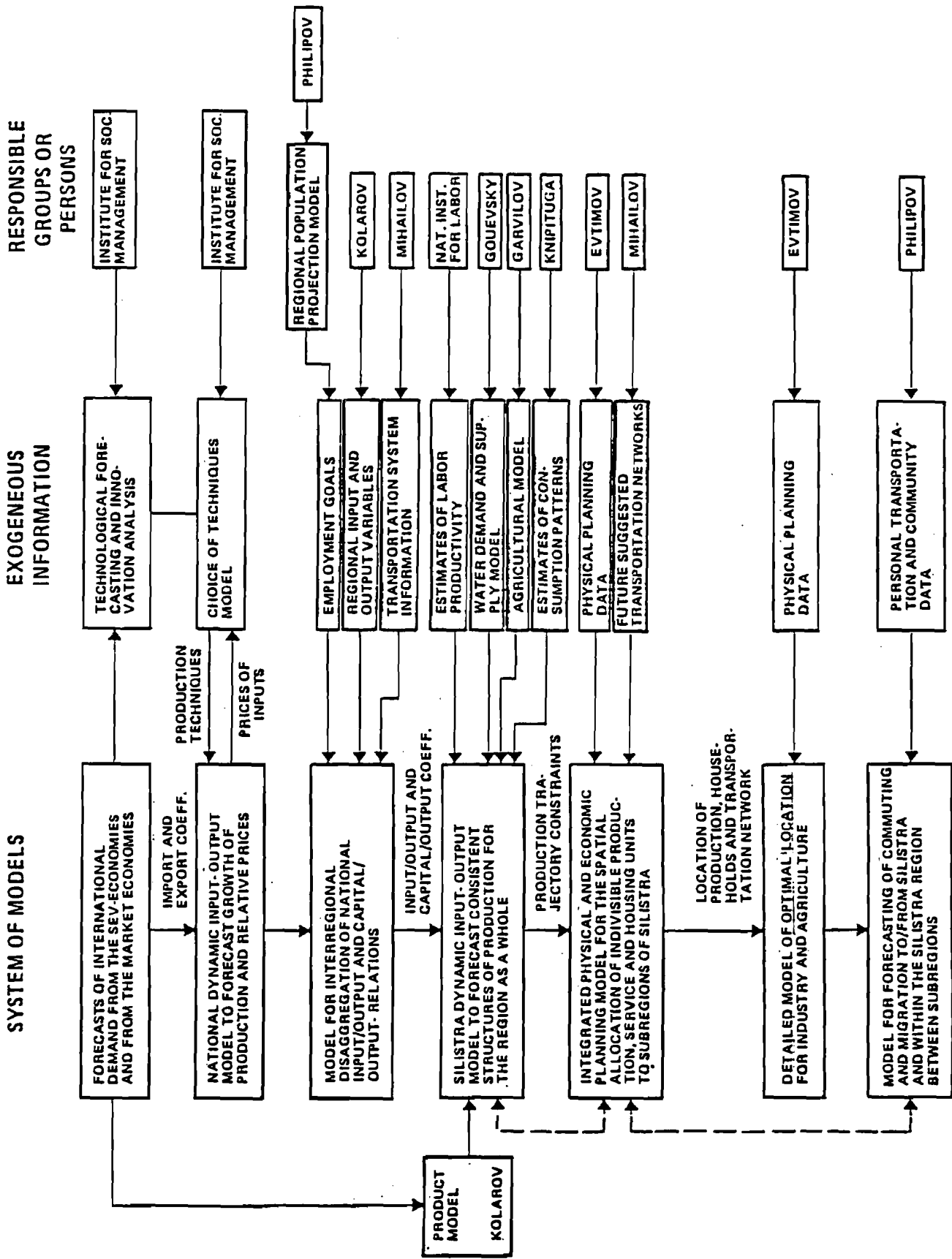

Figure 1. Outline of the Interrelations of Models Proposed for the Silistra Study.

- Leather manufactures;
- Vegetable and animal fats, and oils;
- Grains;
- Clothing;
- Oil refinery products;
- Tobacco;
- Preserved fruit and vegetables; and
- Footwear.

It is obvious from this list that the production and export structure of Bulgaria is to some extent concentrated on products with a slow growth of world demand. As an important example, one can mention tobacco in which Bulgaria is strongly specialized. By the end of the 1960s Bulgaria had approximately 9% of the whole world market for tobacco. The demand for tobacco has been growing very slowly in the 1970s and studies of consumer behavior in the market economies indicate that this product has a gloomy future. It is absolutely necessary from this point of view to make international demand projections for the most important commodities currently being produced in the Silistra region. These projections should also be disaggregated into a set of different marketing areas in the western market economies and in the SEV economies. It would also be advisable to create demand forecasts for some products, that are currently not produced in the Silistra region, but which could in the future be new focal points of industrialization.

#### *Future Technologies and Choice of Techniques*

Another analysis of great importance concerns forecasting of future technologies and the innovation of already available techniques. This analysis should be preferably tied to the actually existing and probable future production sectors of the Silistra region. This does not mean that the analysis should be executed within a narrow regional framework. On the contrary, one must use national and even international data to perform this kind of analysis. Dr. Kolarov has suggested one promising approach to such studies [see his paper in this volume].

The choice of techniques cannot be analyzed without consideration of available resources and input prices. Such input prices must however be generated in some national dynamic input-output model which can forecast the growth of production, primary resource supply, relative prices of all the inputs and the equilibrium rate of interest in the long run. It is thus needed to generate the future input-output matrices iteratively with a national dynamic input-output model and a model for the choice of techniques. The results of this iterative procedure are input-output and capital-output ratios for all the sectors of the Bulgarian economy for the planning years 1980, 1985, 1990 and 1995. (See Figure 7.)

#### *Interregional Trade and Regional Interdependencies*

These national input-output and capital-output coefficients must be disaggregated into their regional and interregional components. This is primarily needed because the creation of regional input-output tables based on actual measurements of the flows is extremely time consuming and would require a major research effort. Secondly, it is hardly possible to create such regional input-output tables also for future time periods. We have thus chosen a technique for optimal disaggregation of the national input-output and capital-output relations. This model, which is described in some detail in the section below, uses the national input-output and capital-output matrices as a priori organizing information. It also uses information about the employment goals for the regions and information about the capacities and frictions of the transportation system. The model for interregional disaggregation of national data then computes the most probable regional and interregional input-output and capital-output tables.

The information about interdependencies between production sectors of Silistra and other regions of Bulgaria are then used as essential information for a dynamic input-output model for the Silistra region. The basic purpose of this dynamic input-output model is to forecast consistent and long-term growth



maximizing structures of production for the Silistra region as a whole. The idea is to subdivide the input-output model into the following sectors:

- |                       |   |                                    |
|-----------------------|---|------------------------------------|
| Animal products       | : | 1. meat                            |
|                       |   | 2. milk                            |
|                       |   | 3. wool                            |
|                       |   | 4. eggs                            |
| Foodstuffs            | : | 5. grain                           |
|                       |   | 6. seed                            |
|                       |   | 7. forage                          |
|                       |   | 8. fruits and vegetables           |
| Cash crops            | : | 9. tobacco                         |
|                       |   | 10. beans                          |
|                       |   | 11. sunflower                      |
| Agricultural products | : | 12. meat products                  |
|                       |   | 13. milk products                  |
|                       |   | 14. leather processing             |
|                       |   | 15. other food-processing industry |
|                       |   | 16. textiles                       |
|                       |   | 17. other                          |
| Industries            | : | 18. machine and metal producing    |
|                       |   | 19. wood processing                |
|                       |   | 20. clothing and footwear          |
|                       |   | 21. fertilizers and chemicals      |
|                       |   | 22. forestry                       |
|                       |   | 23. construction                   |
|                       |   | 24. energy                         |
|                       |   | 25. water                          |
|                       |   | 26. environmental protection       |
|                       |   | 27. trade                          |
|                       |   | 28. communications                 |
|                       |   | 29. social services                |
|                       |   | 30. industrial services            |
| Households            | : | 31. lower education                |
|                       |   | 32. higher education               |

Import-Export : 33. other regions in Bulgaria  
34. (SEV) countries  
35. other countries

To this list should be added two extra sectors of a "dummy" character. These two sectors should be used to test the overall consequences for the Silistra region of the introduction of completely new sectors.

The division of the households into a group of lower and another group of higher education is needed if the problem of bottlenecks in the supply of educated people is to be addressed.

This dynamic input-output model requires separate regional estimates of labor productivity and consumption patterns of the households. It also requires certain coefficients from the water demand and supply model and from the agricultural model. These data requirements cannot be handled at the national level for the simple reason that most of the productivity variations are reflected in the labor productivities and not in the other input-output coefficients. There can also be rather large regional variations in the warranted patterns of consumption. Finally it seems to be necessary to integrate the separate demand and supply models of water, where demand and supply are represented as simple input-output coefficient rows, in columns of the dynamic input-output model for Silistra. In the same way the agricultural models will provide information that must be aggregated into relevant row and column vectors for the simplified Silistra dynamic input-output model.

#### *Integrated Physical and Regional Planning*

The outputs of the dynamic Silistra input-output model should be trajectories of production which can indicate the economic requirements for the spatial planning of the internal structure of Silistra as a set of geographically distinct local communities. The basic idea is thus to generate a projected structure of production in the Silistra region of the future. A set of subareas to be used for location of production and

household units and a number of possible transportation networks to be used as external conditions for the optimality analysis of location patterns must then be generated exogenously by KNIPITUGA, the agency of regional planning.

The model for integrated physical and economic planning does have to handle indivisible units of alternative networks of transportation. The goal function of this model incorporates transportation, investments and congestion, and other environmental costs. This implies that the goal function must be non-linear. The model will thus be handling integer-valued variables at the same time as it treats interdependencies between all the variables. It is also planned to cover a small number of construction periods. The basic problem with this model is to limit the number of variables to keep the model computable. This means that the number of sectors must be restricted (say 6 sectors including households). This in its turn implies that there is a need for a more detailed model of optimal location of industry and agriculture with fine divisions of industry and agriculture into their branches. It is not necessary at this level of analysis to use integer variables. There is also no need for a specification of the timing. This means that the number of sectors can be increased very much and it might also be possible to use some nonlinear goal functions to express the costs of interactions because of the possibility of using the rough physical structure as computed in the integrated physical and economic planning model. The test of the reasonableness of the spatial pattern of production and household location will be tested in an economic model for forecasting of commuting patterns and migration between the subregions of the Silistra region.

Section 4 will contain a detailed discussion of the separate models presented above, and Section 3 focuses on the problems associated with hierarchical systems of regional models.

## THE GAINS AND COSTS OF A HIERARCHY OF MODELS

That the socioeconomic system is complex is beyond any doubt; the efforts required for a quantitative analysis, including modeling and optimization, are often overwhelming given the high dimensionality and the complexity in the coupling and interactions among the variables. Moreover, the nature itself of the socioeconomic systems is such that they defy, almost by definition, a complete and detailed mathematical description.

To tackle the problems of regional development, there is obviously a need to take into account the numerous behavioral aspects of the system under consideration; one is therefore inclined to build a comprehensive model, reproducing as closely as possible the complexity of the real system. However, the use of very complicated and gigantic models has at least two serious shortcomings:

- in the first place, it becomes more and more difficult to maintain a clear understanding of the model behavior throughout the model building process;
- in the second place, the serious limitation of the available optimization techniques as far as high-dimensional nonlinear problems are involved requires drastic simplification of large models, by such means as linearization, in order to allow the use of linear programming methods.

This dilemma between simplicity and complexity can be solved making use of a hierarchical description of the system [Mesarovic, Macko, Takahara (1970)], i.e., building a family of models each concerned either with a specific aspect of the overall system, or with the behavior of the system viewed from a different level of abstraction. This procedure yields a hierarchy of low-dimensional models, which, with the use of suitable theoretical tools and computational techniques, enable one to understand the behavior of the real system through the independent (up to a certain extent) analysis of the single models. Different optimization procedures can also be applied

to the different models (from now on referred to as submodels) of the hierarchy.

It is the purpose of this section to present the mathematical framework for the formulation of the above ideas. In doing this, we freely borrow concepts and symbolism from Mesarovic, Macko, and Takahara (1970) and Mesarovic and Takahara (1975).

Using Mesarovic's terminology, we can distinguish at least five strata, or levels of abstraction, in the representation of a regional system:

- at the highest level of abstraction (the fifth stratum), the region can be viewed as an open entity in a much wider international economic system, allowing for a description in terms of international trade and exchanges;
- at a lower level (fourth stratum), the region can be viewed within its national system, and the description will be in terms of the relationships with the other national components;
- the third stratum is concerned with the description of the regional structure (using, for example, such techniques as input-output analysis);
- on the second stratum the internal regional structure is deeply analyzed, explicitly considering the space concept and making use of sectoral models; from the planning point of view, resource allocation models can be included here; and
- the first stratum is concerned with the detailed study of the spatial distribution and movements of the population (i.e., migration and commuting).

There exists, of course, a strong interdependence among the different strata; however, such interdependence is in many aspects asymmetrical, in the sense that, for instance, the functioning of the international market is likely to affect very much the behavior of a small region; the opposite is not

true in any way. In general we can affirm that the behavior of the higher strata is conditioning the functioning of the lower ones. However, the higher stratum receives feedback information about the lower ones, which provide a substantial basis for its own functioning.

It should also be noted that different strata are concerned with phenomena having different dynamic behavior. As an example, we can affirm that in the representation of the region within the national system we deal with such variables as the interest rate which have a very fast dynamic. On the contrary, in the physical planning level, we are concerned with physical variables, for instance the structure of a transportation network, having a strong "inertia" against changes.

The inclusion, in the hierarchical representation, of the dynamical behavior of the different phenomena is of the utmost importance for a clear understanding of the reciprocal interactions. Each phenomenon must therefore be described in terms of a frequency spectrum of its time variations, analyzing the influence of each subset of frequencies on the dynamics of the other phenomena. A discussion of this problem in the field of control system design can be found in Lefkowitz, I. (1966); the similar problem occurring in the field of regional modeling and planning will be the subject of further research.

Figure 2 provides a pictorial interpretation of the hierarchical approach to regional model building. For understanding how the system works we must go through all the strata, getting more details as we go down the hierarchy, but obtaining a broader description and a better comprehension of the system in a larger environment as we move up the hierarchy.

In order to formalize this approach, we must regard our model as a functional system  $S: X \rightarrow Y$ , where  $X$  is the input set and  $Y$  is the output set. The starting point for a hierarchical approach is the assumption that both the  $X$  and  $Y$  sets can be portioned into components that may be put in correspondence with each stratum:

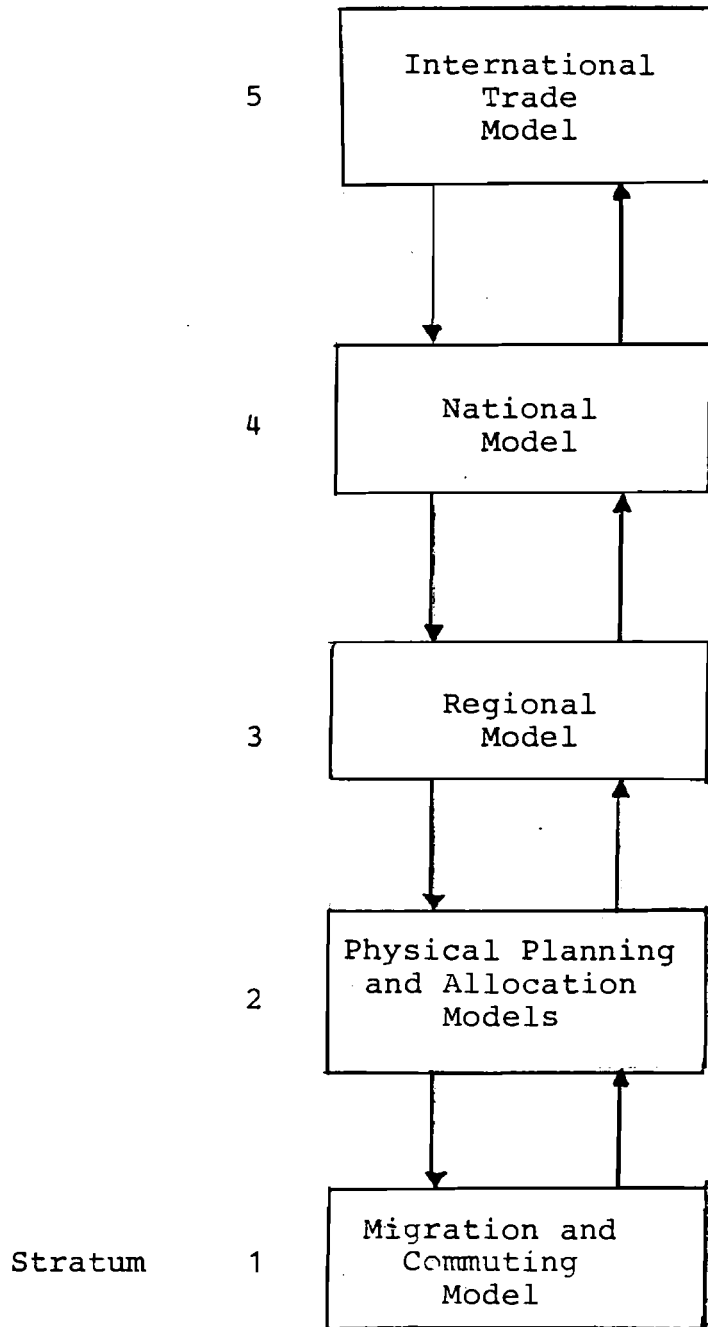

Figure 2. Hierarchical Approach to Regional Model Building.

$$X = X_1 \times X_2 \times \dots \times X_5$$

$$Y = Y_1 \times Y_2 \times \dots \times Y_5$$

Thus, each stratum will be represented with the proper map  $S_i$ :

$$S_5: X_5 \times F_5 \rightarrow Y_5$$

$$S_i: X_i \times C_i \times F_i \rightarrow Y_i \quad 1 < i < 5 \quad (1)$$

$$S_1: X_1 \quad C_1 \quad Y_1 \quad .$$

where  $C_i$  and  $F_i$  represent the sets of stimuli originating respectively from the strata immediately above and below the  $i^{\text{th}}$  stratum.

A necessary condition for (1) to be a stratified representation of the system  $S$  is the existence of the two families of mapping

$$\gamma_i: Y_i \rightarrow C_{i-1} \quad 1 < i \leq 5 \quad (2)$$

$$\phi_i: Y_i \rightarrow F_{i+1} \quad 1 \leq i < 5 \quad (3)$$

representing the interactions among the strata.

Since stratum 2 is evidently a decomposition of the regional system into a convenient number of subsystems, we can go further in our representation. Let us assume that we want to consider  $n$  subsystems, the  $j^{\text{th}}$  of which is a mapping

$$S_{2j}: M_{2j} \times Z_{2j} \rightarrow Y_{2j} \quad (4)$$



where

$$M_{2j} = X_j \times C_{2j} \times F_{2j} \quad ,$$

$$X_2 = X_{21} \times X_{22} \times \dots \times X_{2n} \quad ,$$

$$Y_2 = Y_{21} \times Y_{22} \times \dots \times Y_{2n} \quad ,$$

$$C_2 = C_{21} \times C_{22} \times \dots \times C_{2n} \quad ,$$

$$F_2 = F_{21} \times F_{22} \times \dots \times F_{2n} \quad ,$$

$$M_2 = M_{21} \times M_{22} \times \dots \times M_{2n} \quad ,$$

$Z_{2j}$ : set of inouts through which the subsystem  $S_{2j}$  is coupled with the other subsystems on the same stratum.

The introduction of the interaction variables, coupling the different subsystems, is an obvious consequence of the decomposition. Therefore, for each subsystem, there must exist a further mapping

$$H_{2j}: M_2 \times Y_2 \rightarrow Z_i \quad , \quad (5)$$

which generates the coupling variables.

Denoting with  $\bar{S}_2$  the uncoupled subsystems and with  $H_2$  the couplings with

$$H_2(m, Y) = [H_{21}(m, Y), \dots, H_{2n}(m, Y)] ,$$

$$\bar{S}_2(m_2, z_2) = [S_{21}(m_{21}, z_{21}), \dots, S_{2n}(m_{2n}, z_{2n})] ,$$

the following consistency condition (Mesarovic 1970) must hold for all  $(m_2, Y_2) \in M_2 \times Y_2$ :

$$Y_2 = \bar{S}_2[m_2, H_2(m_2, Y_2)] \leftrightarrow Y_2 = S_2(m_2) , \quad (6)$$

i.e., for all  $m \in M$ , there must exist a unique solution of the system

$$\left\{ \begin{array}{l} y_2 = \bar{S}_2(m_2, z_2) \\ z_2 = H_2(m_2, Y_2) \end{array} \right. , \quad (7)$$

and it must yield the output  $y_2 = S_2(m_2)$ .

It should be mentioned that the coupling functions  $H_i$  are the key elements of the decomposition. In many cases they will simply be projection mappings (i.e., the interface will simply consist of some of the components of  $[m_2, Y_2]$ ), but they can often be somewhat more complicated.

Figure 3 pictorially represents this kind of decomposition.

A particular case arises when only some of the components of  $S_2$  are explicitly considered. In this case, some components of the output  $y_2$  will be unknown. Therefore, rather than the coupling functions  $H_i$ , we should use a kind of interaction function  $K_{2i}$  embodying in some way the overall process  $P$ , i.e.,

$$K_{2i}: M_2 \rightarrow Z_{2i} . \quad (8)$$

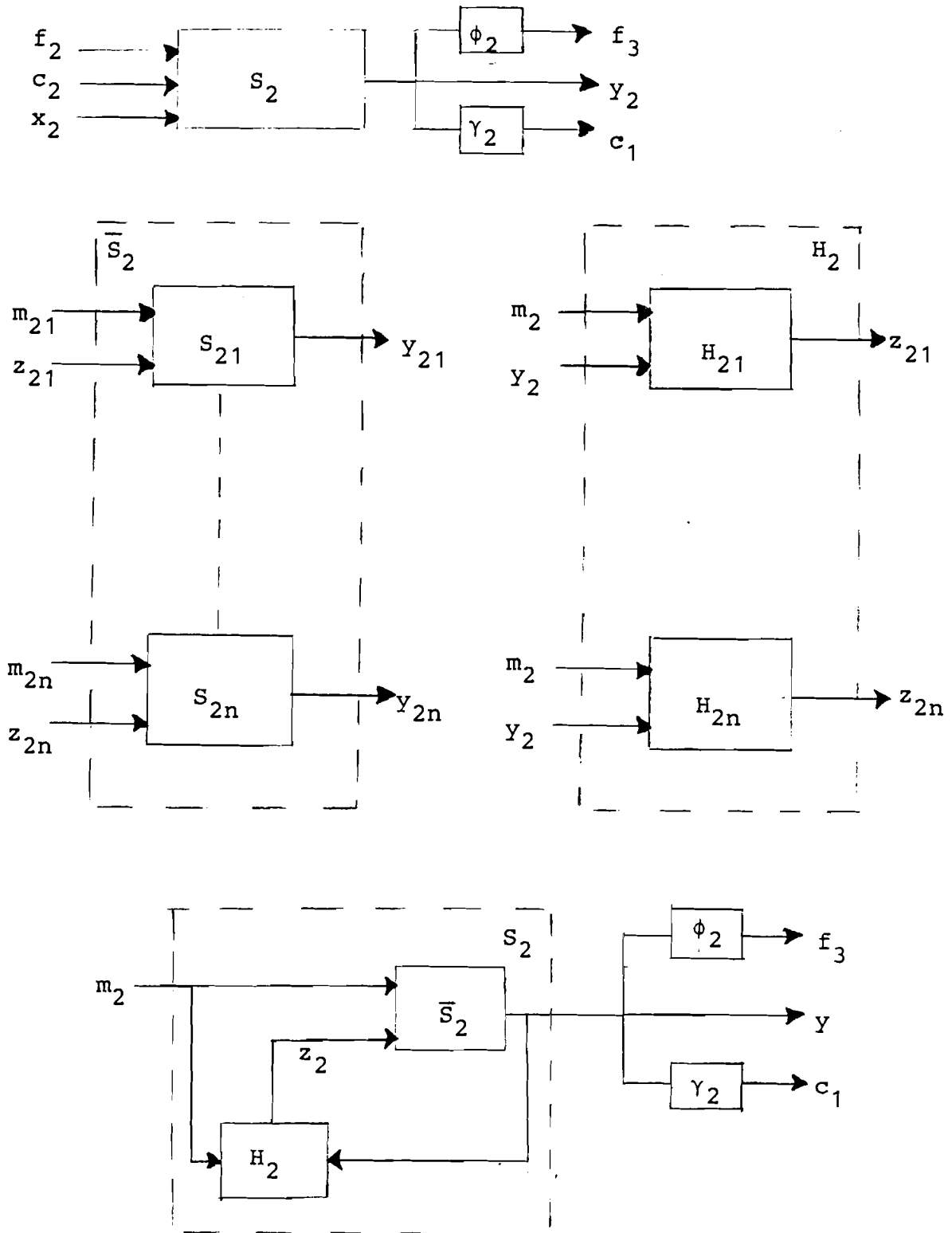

Figure 3. Representation of decompositions.

Then, each subsystem can be seen as

$$S_{2i}(m_{2i}, z_{2i}) = S_{2i}[m_{2i}, K_{2i}(m_2)]$$

where the interactions are expressed as a function of the inputs only.

Also, in this case, there must hold a consistency condition given as

$$y_2 = \bar{S}_2[m_2, K_2(m_2)] \leftrightarrow y_2 = s_2(m_2) \quad (9)$$

with

$$K_2(m_2) = [K_{21}(m_{21}), \dots, K_{2n}(m_{2n})] \cdot$$

Figure 4 shows a pictorial representation of this kind of decomposition.

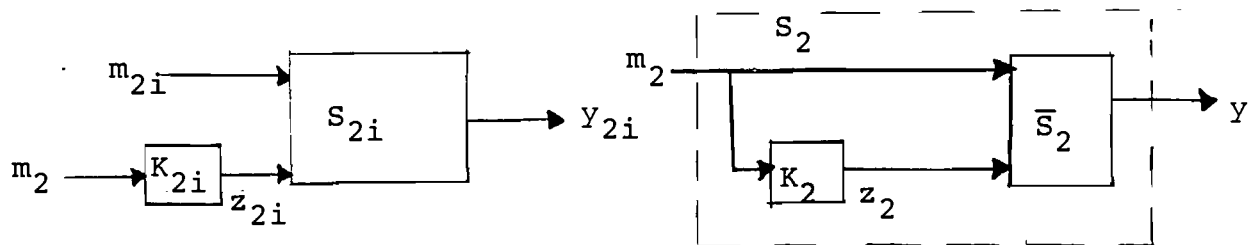

Figure 4. Consistency and decomposition.

So far we have neglected any decision-making aspects in our representation of the system. Now we have to distinguish between decision-making processes based on efficiency criteria, and decision-making processes based on a system of values. Whereas the former can be included in the model, the latter are too closely connected with the identity of the decision makers and change too fast to be susceptible of a mathematical formulation.

On this basis, it seems that, in the structure depicted in Figure 1, the second level is the most suitable for including decisional (optimization) submodels as allocation models, sectoral optimization models, and so on.

With the inclusion of decisional aspects, we would have a family of decision problems  $D_2(m_{2i}, z_{2i})$  associated with the general component of the second level. The relative map then becomes

$$D_{2i}: M_{2i} \times T_{2i} \rightarrow \Gamma_{2i} \quad (10)$$

$$P_{2i}: M_{2i} \times Z_{2i} \times \Gamma_{2i} \rightarrow Y_{2i} \quad (11)$$

where  $h_{2i} \in \Gamma_{2i}$  is a solution of the decision problem  $D_{2i}(m_{2i}, z_{2i})$ . Moreover, there must exist a further map  $\theta_{2i}$  such that:

$$\theta_{2i}: Y_{2i} \times Z_{2i} \rightarrow Y_{2i} \quad (12)$$

A pictorial interpretation is given in Figure 5. The inputs  $m_{2i}$  and  $t_{2i}$  to the decisional unit  $D_{2i}$  fix the values of the parameters and specify which variables must be included in the decision problem of  $S_{2i}$ .

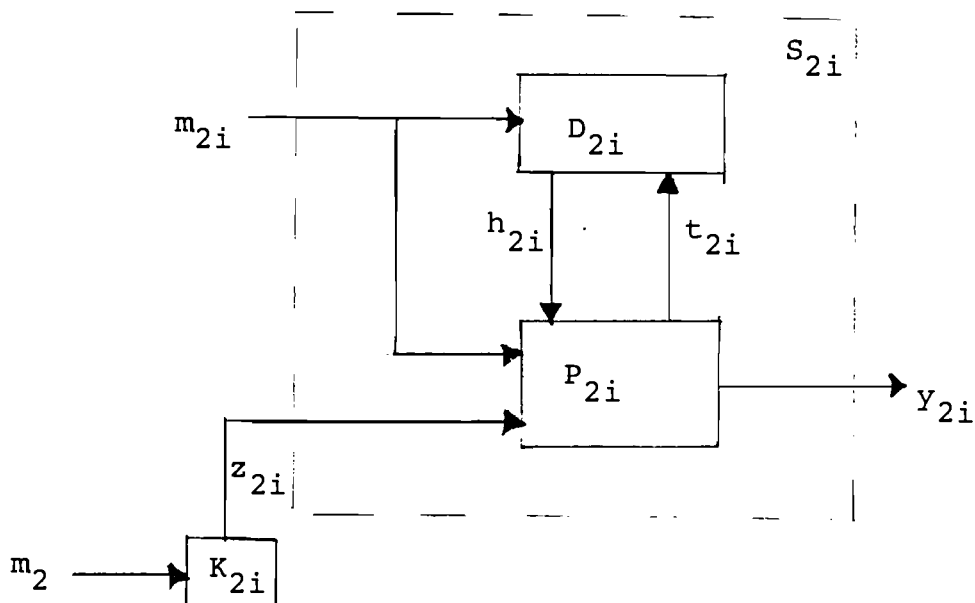

Figure 5. Decisional units and decompositions.

$P_{2i}$  can be used as a representation of the "physical" process to be studied, and  $D_{2i}$  represents the associated decisional unit. The exchanges between the decisional units and the environment occur both directly, through the variables  $m_{2i}$ , for what regards the interaction with the outer environment and the other strata, and through the physical process for what regards the interactions with the other subprocesses within the same stratum.

We turn now to discuss three fundamental topics related to the implementation and use of our hierarchical model for planning purposes. In fact, we should specify:

1. how the model fits in a planning procedure, and what kind of reciprocal interactions there can be with the decision makers;
2. to what extent the responses of each stratum to localised stimuli are themselves localized (in other words, to what extent changes in one of the submodels do not affect the functioning of the others);
3. what advantages can be expected by the use of the proposed model with respect to the alternative use of a "global" optimization model.

1. A possible scheme for understanding the place of a hierarchical model of the proposed type in a planning procedure is illustrated in Figure 6.

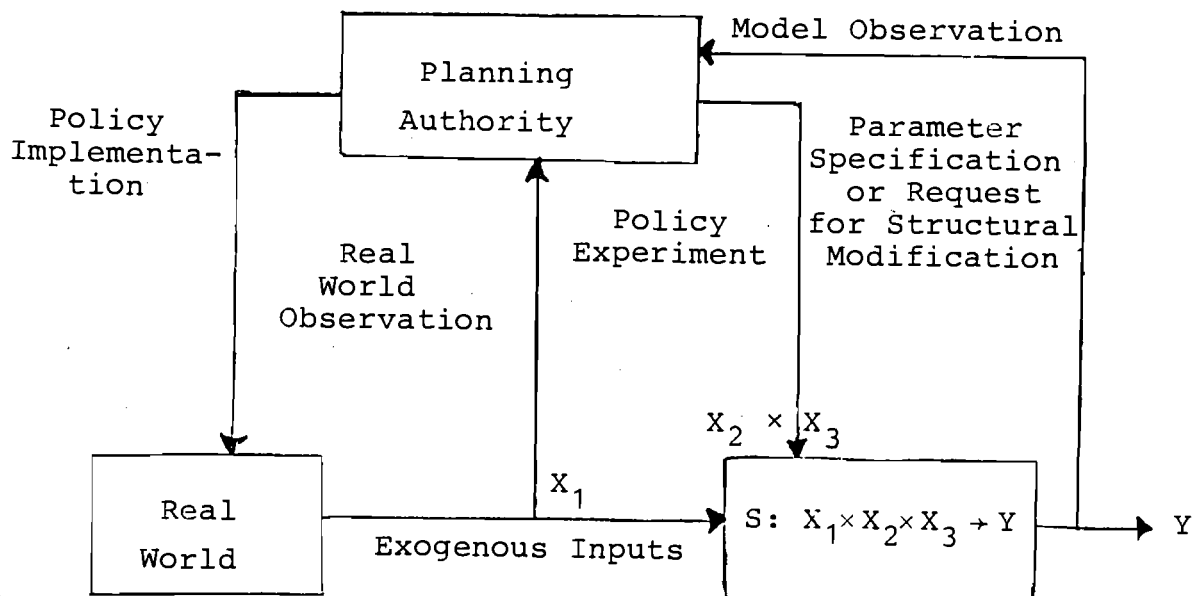

Figure 6. The planning system.

The input set  $X$  to the model is regarded here as the Cartesian product of three subsets  $X_1 \times X_2 \times X_3$ . The first subset represents exogenous input variables coming from the observation of the real world, whereas  $X_2$  and  $X_3$  represent the set of inputs to the model coming from the decision makers. Through  $X_3$  the decision makers would specify the value of some of the parameters of the model, or request structural modification, whereas  $X_2$  represents the set of possible planning policies. Hence, there is the need of building an adaptive model, able to allow partial structural changes in some of its submodels.

It is quite clear, from the scheme of Figure 5, that the proposed model is a scenario-generating model, rather than an optimization one. However, since the model incorporates optimization procedures, we can observe that those scenarios would be generated under maximum effectiveness conditions according to the characteristics of each subsystem and the specification of its effectiveness criterion.

Therefore, in the whole planning procedure, we would have two decisional stages, one mathematically formalized at the model level, and the other, more general and more important, embodied at the planning authority level and based on an implicit and not formalized performance index of the whole system as perceived by the decision makers.

The structure of the model is such that there would not be any coordination problem in the sense of Mesarovic (1970). However, we can expect that the set of values and perceptions, which are the basis of the planning authority decisions, will change over time. We can also expect that the insight gained with the use of the model will effect that change.

2. It is evident that responses to changes in the stimuli  $x_i$  will be completely localized in the  $i^{\text{th}}$  stratum if there is no change either in  $c_{i-1}$  or in  $f_{i+1}$ . In fact, using (2) and (3), an alternate representation to (1), can be the following:

$$y_5 = S_3[x_5, \phi_4, (y_4)]$$

$$y^i = S_i[x_i, \gamma_{i+1}(y_{i+1}), \phi_{i-1}(y_{i-1})] \quad 1 < i < n \quad (13)$$

$$y_1 = S_1[x_1, \gamma_2(y_2)]$$

Therefore, more formally, we can affirm that the response of the  $i^{\text{th}}$  stratum is completely localized if, for any  $(c_i, t_i) \in C_i \times F_i$ ,

$$\gamma_i[S_i(x_i, c_i, f_i)] = \gamma_i[S_i(x'_i, c_i, f_i)] \quad (14)$$

$$\phi_i[S_i(x_i, c_i, f_i)] = \phi_i[S_i(x'_i, c_i, f_i)]$$

for any  $x_i$  and  $x'_i$  in  $X_i$ .

A completely localized model would have very little in common with the real world. However, the assumption is quite realistic that  $S_i$  be partially localized; i.e., that there exist subsets  $\bar{C}_i \subseteq C_i$ ,  $\bar{F}_i \subseteq F_i$ ,  $\bar{X}_i \subseteq X_i$  such that condition (14) holds for any pair  $(c_i, f_i) \in \bar{C}_i \times \bar{F}_i$  and any  $x_i$  and  $x'_i$  in  $\bar{X}_i$ . The identification of those subsets would be of very great importance because it would allow the generation of many different scenarios without running the whole model again.

3. We conclude this section by summing up the advantages of hierarchical models in the solution of large-scale problems:

- the use of a multilevel model structure allows one to maintain a clear understanding of the system behavior throughout the model-building procedure;
- it allows one to reduce the dimensionality of each sub-model, so that sophisticated nonlinear mathematical techniques can be used;
- the study of the interactions arising among the sub-models because of the decomposition often leads to a good conceptual understanding of the functioning of the whole system;



- there is no restriction to static models; dynamic submodels can be embodied in the hierarchical structure, and dynamic optimization techniques can be used;
- finally, hierarchical models have a high degree of adaptability and flexibility which is of particular relevance for planning purposes. In fact, requests for structural changes are likely to be frequent to keep the model up to date and to keep up with the changing views of the decision makers. In this case, a hierarchical structure would often allow a localized intervention on some submodels, without the need of a complete restructuring.

#### THE NATIONAL AND INTERREGIONAL LEVEL OF ANALYSIS

##### *Technological Development and Technical Choice*

The problem of technological development basically contains four stages of analysis.

The first stage to be considered is the inventive process in which genuinely new knowledge is created. The second stage concerns the actual preparation of the invention for a production process. The third stage concerns the choice of a distinct best set of innovative techniques to be used in the economic system from the point of view of minimization of costs or maximization of long-run profits. Finally, there is an important element which we would call the administrative element, and which concerns the actual problem of implementation of the cost-minimizing or profit-maximizing techniques.

We will not dwell upon all these different aspects of technological development in this context, although they should be discussed at later stages of this project. We will just discuss the limited problem of optimal choice of techniques from a set of innovations, where the criterion of optimality is minimization of long-term costs. Figure 7 outlines the basic principle.

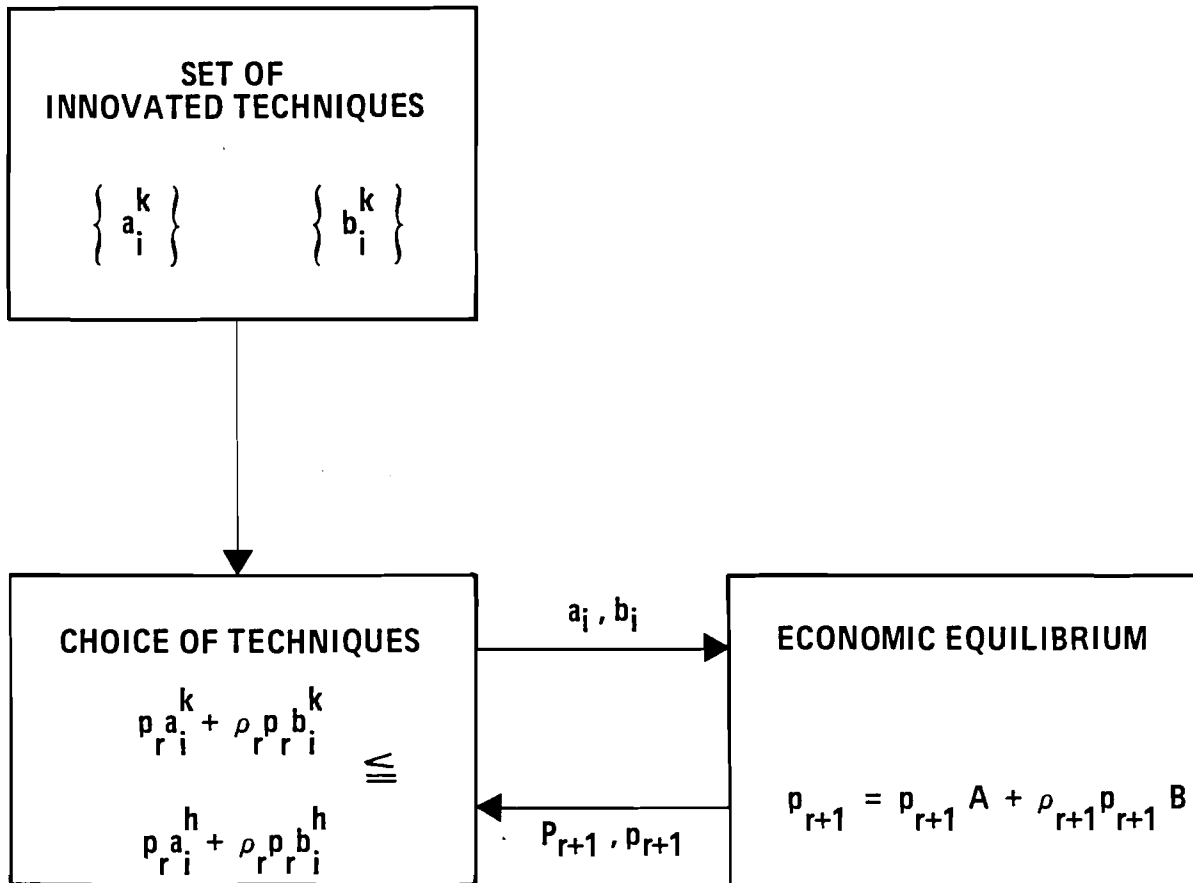

WHERE  $h, k =$  TECHNIQUE ( $h, k = 1, \dots, K$ )

$i =$  SECTOR ( $i = 1, \dots, n$ )

$p =$  PRICE VECTOR OF DIMENSION  $n$

$a_i^k =$  COLUMN VECTOR OF INPUT-OUTPUT COEFFICIENTS OF SECTOR  $i$  WITH TECHNIQUE  $k$

$b_i^k =$  DITTO FOR CAPITAL OUTPUT COEFFICIENTS

$r =$  ITERATION  $r$

$\rho =$  RATE OF INTEREST

Figure 7. Model of choice of techniques.

The principle of choice of techniques (see Brody 1970) outlined above consists in the following optimum-equilibrium problem. The cost and revenues of production can be calculated with the following equations:

$$\text{Revenues of sector } i = p_i x_i ,$$

where

$p_i$  = price per unit of commodity from sector  $i$ ; and

$x_i$  = volume of commodity produced in sector  $i$ .

Cost of production in sector  $i$  =

$$\underbrace{\sum_j p_j a_{ji} x_i}_{\text{current input cost}} + \rho \underbrace{\sum_j p_j b_{ji} x_i}_{\text{capital input cost}} ,$$

current  
input  
cost

capital  
input  
cost

where

$a_{ji}$  = fixed technical input-output coefficient giving the amount of input  $j$  needed to produce one unit of output  $i$ ;

$b_{ji}$  = fixed technical capital-output coefficient giving the amount of input  $j$  required to increase production of output  $i$ ; and

$\rho$  = real rate of interest on capital (assumed to be borrowed from financial institutions or the owners).

The equilibrium condition of entry and exit can be formulated as:

$$p_i x_i \leq \sum_j p_j a_{ji} x_i + \rho \sum_j p_j b_{ji} x_i \quad (i = 1, \dots, n) .$$

It is relevant to ask if there would exist any  $\rho^*$  such that:

$$p_i x_i = \sum_j p_j a_{ji} x_i + \rho^* \sum_j p_j b_{ji} x_i ; \quad (i = 1, \dots, n) .$$

It is obvious that  $x_i$  can be eliminated from the system, which means that:

$$p_i = \sum_j p_j a_{ji} + \rho^* \sum_j p_j b_{ji} ; \quad (i = 1, \dots, n) ,$$

or equivalently with matrix notation:

$$p = pA + \rho^* pB ,$$

which is the common linear eigen-value problem. This can be transformed into an eigen-value problem with non-negative matrix by postulating  $\rho$  as given and equal to  $\bar{\rho}$  and inserting a new corresponding eigen-value  $\lambda$ :

$$\lambda p = p(A + \bar{\rho}B) \equiv pQ(\bar{\rho}) .$$

This problem will be solvable for  $p \geq 0$  and  $\lambda > 0$  according to the theorem of Frobenius (see for example, Nikaido 1968).

If the maximal eigen-value  $\lambda$  (the only positive one) would be less than 1, it would indicate that the rate of interest would be too small in the sense that the firms would get excessive profits. If, on the other hand,  $\lambda$  would be larger than 1, this would indicate that the economy was running at a loss for the sectors, a situation that would be a long-term disequilibrium solution. Only at a value of  $\lambda = 1$  would the economy be in an equilibrium in the long run. The corresponding value of  $\rho$  would then be the equilibrium real rate of interest on capital.

It is consequently possible to use an iterative scheme in which the final solution for  $p$  is determined by successive

changes of  $\bar{\rho}$  until  $\lambda 1$ . This procedure would also make the computation possible without any inversion of the matrix B.

Frobenius's theorem ensures the existence of a unique solution for  $\rho$  and a corresponding price-structure  $p \geq 0$ . This means that for any  $(A, B) \geq 0$  there will exist a unique pair  $(p, \rho)$ . These prices and the equilibrium rate of interest can be used to evaluate the best choice of technique out of the rectangular matrices  $A^R$  and  $B^R$  which are assumed to be pre-determined, rectangular matrices of innovated technological possibilities. These matrices will consequently be of the following form.

$$A^R = \begin{bmatrix} a_{11}^1 & a_{11}^2 & \dots & a_{11}^k & \dots & a_{1j}^1 & \dots & a_{1j}^H & \dots \\ \cdot & \cdot & & \cdot & & \cdot & & \cdot & \\ \cdot & \cdot & & \cdot & & \cdot & & \cdot & \\ \cdot & \cdot & & \cdot & & \cdot & & \cdot & \\ a_{n1}^1 & a_{n1}^2 & \dots & a_{n1}^k & \dots & a_{nj}^1 & \dots & a_{nj}^H & \dots \end{bmatrix}$$

and

$$B^R = \begin{bmatrix} b_{11}^1 & b_{11}^2 & \dots & b_{11}^k & \dots & b_{1j}^1 & \dots & b_{1j}^H & \dots \\ \cdot & \cdot & & \cdot & & \cdot & & \cdot & \\ \cdot & \cdot & & \cdot & & \cdot & & \cdot & \\ \cdot & \cdot & & \cdot & & \cdot & & \cdot & \\ b_{n1}^1 & b_{n1}^2 & \dots & b_{n1}^k & \dots & b_{nj}^1 & \dots & b_{nj}^H & \dots \end{bmatrix}$$

From these rectangular matrices of innovated technologies one specific set of techniques expressed as the quadratic matrices A, B should be chosen.

A technique, like the  $(a_i^K, b_i^K)$  - column vectors should be preferred if the condition:

$$\frac{\sum_j p_{rj} (a_{ji}^k - a_{ji}^h)}{\sum_j p_{rj} (b_{ji}^h - b_{ji}^k)} < \rho_r ; \quad \forall h \in R .$$

where

$p_{rj}$  = relative price of commodity  $j$  in iteration  $r$ .

The total equilibrium problem can be formulated as the problem of finding the solution to the problem

$$p = pA(p, \rho) + \rho pB(p, \rho) \quad .$$

This can be regarded as a standard fixed point problem or a nonlinear eigen-value problem. In either formulation the existence of an equilibrium solution can be proved. We thus know that it is reasonable to formulate an iterative search for a national technical choice strategy and a corresponding equilibrium set of prices and rate of real interest to guide the allocation of resources among sectors of production.

The result of the technical choice procedure outlined is a consistent set of techniques  $\{a_{ij}\}$  and  $\{b_{ij}\}$  to be used as constraints on the derivation of regional input-output and capital-output coefficients  $\{a_{ij}^{rs}\}$  and  $\{b_{ij}^{rs}\}$ . A model for derivation of such trade and technology coefficients is given in the following section.

*Transportation, Trade and Intersectoral  
Relations Between and Within Regions*

The formulation of the equilibrium problem in trade and transportation is in some contexts based on a purely economic reasoning at the micro level. Lefeber (1958) analyzed the problem of personal and commodity transportation within such a microeconomic framework. The transportation sector is in his analysis looked upon as a purely intermediate sector in which transportation needs (rather than demands) are seen as functions of the location of production and inputs. Transportation supply is on the other hand seen as an unlocalized production of services regulated by conventional, concave, always differentiable production functions. The network is totally implicit in this kind of transportation equilibrium

approach. With suitable assumptions about the individual utility and production functions for the nontransportation sectors, it can be proved within this framework that an equilibrium must be such that the difference between FOB- and CIF-prices is equal to the marginal costs of transportation for each one of the consumer commodities. It can also be shown that the marginal value product of each factor must be equal to the scarcity rent of the factor of production plus the marginal cost of transportation of the same factor. Such a transportation equilibrium is a possible but a very restricted definition of a transportation equilibrium. One of the most important implications is the result that there can be no cross-hauling of similar commodities or persons, an implication that is grossly at variance with observations at all statistically possible levels of aggregation.

The concept of equilibrium used in this class of model should not really be viewed as a microeconomic behavioral concept. It is rather formulated within the framework of neo-classical welfare economics. This kind of model presumes the existence of some agent that maximizes a weighted sum of utilities from consumption accruing to all the individual households. There are no real suppliers of commodities and transportation, and only production functions act as constraints. It has been an argument used in microeconomic studies without any global maximization function, that individual consumers maximizing their own utility in congested situations on the road network will never act in such a way that a Lefebvre-equilibrium is achieved. Instead of looking at the socially relevant marginal costs of transportation, consumers will only take into account the average costs of the system.

It thus seems evident that one can subdivide the equilibrium concepts for the transportation system according to the fundamental level of inquiry. A completely micro-oriented approach would demand that each user of the transportation system is looked upon as a decision unit located at every instant of time on some link connecting some pair of nodes. It must

also be assumed that the micro decision unit has no incentive to change this decision. It seems natural to assume that decisions can only be taken in the nodes. In order to get a global equilibrium of such a micro specified transportation network the ex ante- and the ex post-evaluation of equilibria at every point in time and space must coincide.

The Lefeber type of model and thus also most other neo-classical transportation models suffers from another weakness. It does not have the capacity to handle the production interdependencies of input-output economies.

Practical trade and transportation network analysis is often performed within the framework of the assignment/ transportation model approach. This is a very special variant of a Lefeber model. A macro planner is assumed to exist and this macro planner minimizes a total cost function (often assumed to be linear) with all the trips as arguments. The production functions are substituted with quantitative transportation needs as constraints. The transportation system is represented by estimated minimal costs of movement between each pair of nodes in the network. If a linear goal function is used the transportation pattern regularly turns out to be too concentrated as compared with statistical data (Nijkamp 1975).

Our approach to the transportation problem is macro oriented and yet an equilibrium approach in the macro sense. We have taken the dynamic interregional growth and allocation model as an a priori organizing principle of the flows in space. That model organizes the allocation of production regionally of the different sectors of production in such a way that demands and supplies are equated in the different nodes of the network and with a criterion that the rate of capacity use will be maximized for any given expectations of growth in demand for the products. Alternatively, the model can be used in such a way that it maximizes the rate of growth of the production system as a whole. But such an allocation of production is not the only a priori information that has to be fulfilled by the pattern of transportation. Politicians



normally require spatial interactions to be such that they are consistent with certain political goals. It is common in economically developed societies to require the economic system to work in such a way that some politically determined full employment level is achieved in each one of the nodes (regions). There is also regularly some requirements that the use of the transportation system would not be excessively resource consuming. Such a goal can be expressed as a constraint for the whole system or, in a more specified situation, for links connecting pairs of nodes.

We argue that any transportation pattern is in equilibrium if it is such that it preserves a balance situation on each one of the regionally differentiated markets for commodities, and is consistent with goals like full employment and some given level of conservation of resources in the use of the network, and will not require any further coordination of the flows on the network.

One can consequently argue that an equilibrium of the transportation system should be such that it fulfills all economic and political requirements, while it distributes the traffic over the system in such a way that it requires a minimum amount of organization at work. We have understood the principle of maximum entropy to be such a minimum organization principle.

Another way to argue about the distribution of trade and traffic on the transportation system is to assume that the market equilibrium, employment and network constraints are given and regard the formally observed pattern of transportation as the structure that requires the least amount of reorganization of decisions. This approach would then define the equilibrium distribution of transportation flows to be the most conservative in the sense that it gives the minimal deviation of flows from a pattern observed in earlier periods.

These two principles will give similar results under very special assumptions.

We also assume that the politicians require a certain level of employment to be achieved in each one of the regions, while they feel completely free to vary the product flows between sectors and regions as long as it is consistent with full employment.

$$\sum_i n_i^r \sum_{j,s} x_{ij}^{rs} = \bar{s}^r \quad \text{Full employment}$$

$n_i^r$  = labor output ratio for sector i, when located in region r

$\bar{s}^r$  = politically defined level of full employment.

system should be used in such a way that flows are compatible with the design capacity, either as defined at the absolute macro level or with respect to the shortest route links between pairs of nodes.

$$\sum_{i,j} c_{ij} x_{ij}^{rs} = x^{rs}$$

$c_{ij}$  = volume of commodity i per unit of delivery to sector j

$$\sum_{ij,rs} c_{ij} d^{rs} x_{ij}^{rs} = T$$

$d^{rs}$  = distance on shortest route between region r and region s

T = distance dependent capacity of transportation network.

We have discussed above principles of equilibria on transportation and trade networks. It is now time to formalize some of these arguments within the framework of a computable model approach. To simplify the analysis we will from now on assume that the transportation network is given. This means that the links on the network and the nodes are predetermined both in terms of capacity and in terms of location. What we are discussing now is consequently an equilibrium transportation and trade problem in a restricted sense. We will further assume, although only as an intermediate step, that the pattern of location of all kinds of production is predetermined. This means that there is a consistency requirement both from the output side as well as from the input side of the economy:

$$\sum_{s_j} x_{ij}^{rs} = x_i^r \quad \underline{\text{Output balance}}$$

$$\sum_r x_{ij}^{rs} = a_{ij} x_j^s + b_{ij} \Delta x_j^s = (a_{ij} + b_{ij} g_j^s) x_j^s \quad \underline{\text{Input balance}}$$

or

$$\sum_r x_{ij}^{rs} = a_{ij} (1 + g_j^s T_j) x_j^s$$

where

$x_{ij}^{rs}$  = flow of commodities from production sector i, located in region r to production sector j located in region s

$g_j^s$  = expected or planned rate of growth in sector j, region s

$x_j^r$  = total production in delivery sector i located in region r

$T_j$  = turnover time for commodity j.

The trade-transportation equilibrium model can now be formulated in the following way:

$$\max_{\{x_{ij}^{rs}\}} : - \sum_{\substack{ij \\ rs}} x_{ij}^{rs} \ln x_{ij}^{rs}$$

subject to:

Lagrange multiplier

$$\sum_r x_{ij}^{rs} = a_{ij} (1 + g_j^s T_i) x_j^s ; \quad \mu_{sj}$$

$$\sum_{s,j} x_{ij}^{rs} = x_i^r ; \quad \eta_{ir}$$

$$\sum_i n_i^r \sum_{js} x = S^r ; \quad \gamma_r$$

$$\sum_{i,j} c_{ij} x_{ij}^{rs} = X^{rs} ; \quad \text{some } r, s \quad \beta_{rs}$$

$$\sum_{\substack{i,j \\ r,s}} c_{ij} x_{ij}^{rs} d^{rs} = T ; \quad \gamma$$

The optimal solutions for  $x_{ij}^{rs}$  in this problem will be of the form:

$$x_{ij}^{rs} = \exp(\mu_{sj} + \eta_{ir}) \exp[\beta_{rs} c_{ij} + \gamma_r n_i^r + \lambda c_i d^{rs}]$$

which says that trade between sector  $i$  in region  $r$  and sector  $j$  in region  $s$  expands

- a. if the technological interdependency increases between  $i$  and  $j$ ;
- b. if production located to area  $r$  or  $s$  of activity  $i$  and  $j$  increases; and
- c. if the capacity of transportation on some links or the distance dependent transportation capacity (cars, trucks, trains, etc.) increases.

It is obvious that congestion phenomena will occur only in certain region combinations which call for inequalities in the link constraints. It is probably possible to revise the algorithm in such a way that it will be capable of handling inequalities in the constraint set. Such an amendment is necessary if the capacities of the transportation network should be properly represented.

The result of this model is a nationally consistent set of input-output  $\{a_{ij}^{rs}\}$  and capital-output  $\{b_{ij}^{rs}\}$  coefficients that can be used for interregional dynamic/economic analysis and projections. We will not propose to use the interregional information in this context.

It is rather our proposal to use the matrices  $\{a_{ij}^{rr}\}$   $\{b_{ij}^{rr}\}$  plus aggregated import- and export-coefficients for the Silistra region.

The dynamic order of determination of the variables must be observed at this stage.

As the most stable element of the spatial system we use the national transportation network ( $d^{rs}$ ). It is assumed that the basic structure of such a network can be changed only over an extremely long time period (say 30-50 years).

The location/allocation pattern is assumed to be changeable within a time period corresponding to 5-15 years. The transportation system, when used for trade in commodities, is assumed to react almost instantaneously to changes in the network and the pattern of location and allocation.

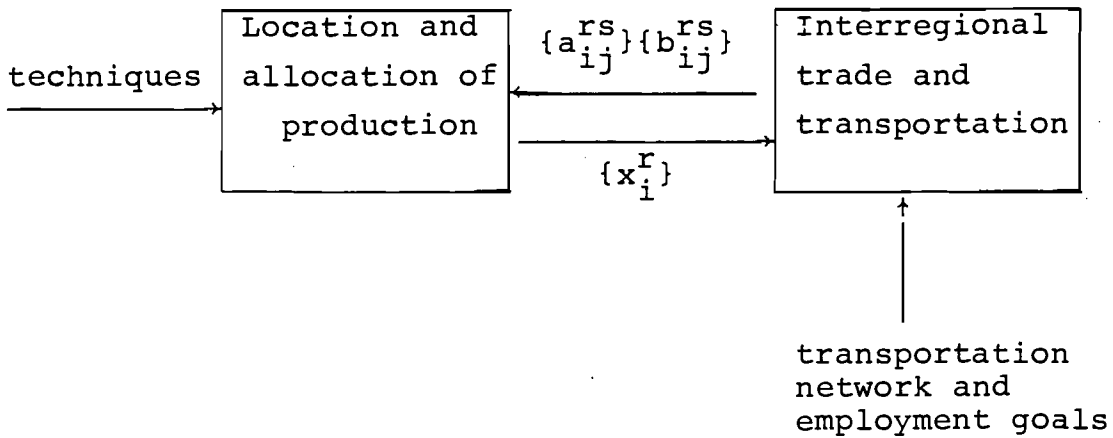

Figure 8. The Silistra dynamic allocation modeling problem.

It must finally be stressed that the interactions between the interregional location/allocation and transportation/trade models should ideally be modeled in a completely interdependent pattern, as illustrated above in Figure 8.

#### THE SILISTRA DYNAMIC ALLOCATION MODELING PROBLEM

As concluded in the preceding section, the interregional trade and transportation model can produce interregionally consistent regional input-output and capital-output coefficients. These estimates provide the most essential information for a study of the future production and employment structure of the Silistra region. To this information should be added the important coefficients of labor productivities, or their inverses--the labor-output coefficients. It is not possible to use the assumption that these productivities are the same everywhere in Bulgaria. Ample evidence indicates that labor productivities show great and systematic variation among regions. The factors of greatest importance to the labor productivities are:

1. Educational background;
2. Health status;
3. Vocational training; and
4. Environmental conditions.

We have for this reason concluded that there must be some separate studies of the effects of health, vocational training, and environmental investments on labor productivity in the different sectors. It is suggested that the educational dimension is treated differently. It is both possible and for planning purposes more reasonable to disaggregate labor into at least two labor "sectors"--of high and low formal education level. In this way it is also possible to integrate some of the important problems of educational supply through schooling or migration between regions.

With the subdivision of labor into two or more categories there should be a corresponding subdivision of the households as consumers. For each period there is thus a need to estimate labor-output coefficients  $t_{ej}^l$  and  $t_{ej}^c$ , where

$t_{ej}^l$  = labor use of category e at time t per  
unit of production in sector j

and

$t_{ei}^c$  = consumption of commodity i by category e at  
time period t per unit of labor.

In the long run the consumption coefficients must, of course, be looked upon as functionally determined by income per capita, price structures, etc.

The demand from other parts of the world as well as demand from Silistra vis-à-vis other parts of the world is of great importance to the construction of the model. Some of this information--on trade with other parts of Bulgaria--comes from the interregional trade and transportation model.

For these purposes we suggest the use of aggregated coefficients giving the import and export relations from Bulgaria to and from the Silistra region.

This approach cannot be used for the interrelations with the world market (disaggregated into SEV and market economies).

For international demand projections it is necessary to forecast the import and export coefficients for each one of the sectors of Silistra under different world trade scenarios. We thus need three sets of coefficients:

$$t^u_i \text{ and } t^v_i ; \quad t^e_i \text{ and } t^m_i ; \quad t^w_i \text{ and } t^z_i$$

where

$t^u_i$  = export of commodity  $i$  per unit production to rest of Bulgaria;

$t^v_i$  = import of commodity  $i$  per unit production from rest of Bulgaria;

$t^e_i$  = export of commodity  $i$  per unit production to the SEV area;

$t^m_i$  = import of commodity  $i$  per unit production from the SEV area;

$t^w_i$  = export of commodity  $i$  per unit production to market economies; and

$t^z_i$  = import of commodity  $i$  per unit production from market economies.

Some sectors are modeled with separate models like those for agriculture and water.

In these cases it is obvious that one should use aggregates of input-output and capital-output coefficients derived in these highly specified models. Finally, a most important question must be addressed, namely, the issue of new sectors not yet created in the Silistra region.

Summarizing: The general framework of modeling at the level of Silistra as a whole is suggested to be within the framework of dynamic input-output analysis with a primary reference to the approaches discussed in Brody (1970).

The input-output matrix to be used in this specific case has the design as in the Table below.



Table 1. Simplified input-output table.

Table of coefficients in Silistra snapshot model.

From \ To	Purchasing Sectors 1,2,...,28	Social service	Industrial service	Low educ. households	High educ. households	Other regions in Bulgaria	SEV	Other Countries	
Purchasing sectors	1 2 . . . 28	$a_{ij}, b_{ij}$	$a_{is}$	$a_{iI}$	$C_{li}$	$C_{hi}$	$E_{Bi}$	$E_{Ki}$	$E_{Ri}$
Social service	0,0,0,...,0	0	0	$a_{shl}$	$a_{shh}$	0	0	0	
Industrial service	$a_{s1}, a_{s2}, \dots, a_{s28}$	0	0	0	0	0	0	0	
Low educ. households	$a_{l1}, a_{l2}, \dots, a_{l28}$	$a_{ls}$	$a_{lI}$	0	0	0	0	0	
High educ. Households	$a_{h1}, a_{h2}, \dots, a_{h28}$	$a_{hs}$	$a_{hI}$	0	0	0	0	0	
Other regions in Bulgaria	$m_{B1}, m_{B2}, \dots, m_{B28}$	$m_{Bs}$	$m_{BI}$	$m_{Bl}$	$m_{Bh}$	0	0	0	
SEV	$m_{K1}, m_{K2}, \dots, m_{K28}$	0	0	0	0	0	0	0	
Other countries	$m_{R1}, m_{R2}, \dots, m_{R28}$	0	0	0	0	0	0	0	

A closed dynamic model of the Silistra region could then take on the following appearance:

$$X(t) \geq A(t)X(t) + B(t)\Delta X(t) \tag{I}$$

where

$X(t) \equiv \{X_i(t)\}$  = vector of output per unit of time in time period  $t$  for the  $i = 1, \dots, n$  sectors of Silistra,

$\Delta X(t) \equiv \{\Delta X_i(t)\}$  = vector of production increases over time period  $t$ ,

$A(t) \equiv \{a_{ij}(t)\}$  = input-output coefficients in time period  $t$  (including households and interregional and international sectors),

$B(t) \equiv \{b_{ij}(t)\}$  = capital-output coefficients in time period  $t$ .

We can now make the convenient assumption that we are looking for a solution for which the common rate of growth  $\lambda$  (in  $\Delta X(t) = \lambda X(t)$ ) is the maximal, while there is an exact balance between production and input requirements in all sectors.

We then have the system of equations:

$$X(t) = A(t)X(t) + \lambda(t)B(t)X(t) \quad .$$

If we further assume that the elements  $b_{ij}(t) = T_i(t)a_{ij}(t)$ , where  $T_i$  = turnover time of commodity; in the production process, we have

$$X(t) = [A(t) + \lambda(t)\hat{T}(t)A(t)]X(t) \quad . \quad (II)$$

A solution scheme for this problem would be to form the matrix:

$$Q = (I - A)^{-1}\hat{T}A = (I + A + A^2 + \dots)(\hat{T}A) = \hat{T}A(A + A^2 \dots)$$

and then to solve the problem

$$\beta X = QX \text{ where } \beta = \frac{1}{\lambda}$$

where  $\beta$  is the only positive and maximal eigen-value. To this corresponds a unique positive rate of growth  $\lambda$  with a corresponding semipositive vector of production shares (i.e.,  $X_i \geq 0$ ) for all sectors.

From the numerical point of view, this is a simple and useful approach to the problem of scenario projections of the production structure for Silistra. It only involves the computation of the Q-matrix and the subsequent calculation of the maximal eigen-value and the corresponding eigen-vector. For these purposes standard computer subroutines exist and can be implemented immediately.

The dynamic system (I) can also be used as a set of constraints in an optimal control model, beside constraints on the natural and human resources. We would, however, recommend the use of the more simple balancing model (II) in the initial phases and to formulate optimal control models (or equivalent temporal programming models) only at a late stage, when the interdependencies have become better known and the number of interesting long-range scenarios have been narrowed down to a limited set.

*Integrated Physical and Economic Planning*

The KNIPITUGA institute has a responsibility for the Silistra project. It also has its own research focus and planning responsibility in location and transportation planning. This implies that models for overall economic planning for the Silistra region are not enough, but that planning should be completed with models for integrated long-term physical and economic planning.

Although oriented to smaller regional units, the analytical complexity of planning is very large. The subdivision of the region into a set of zones and subregions necessarily implies an increasing importance of threshold or indivisibility, leading to increasing returns to scale in production. We thus have to deal with either: indivisibilities (combinatorial analysis) or nonconcave production functions.

The physical planning approach is normally to work within indivisibility or combinatorial analysis. This means that the primary objects are indivisible units like production plants, housing and service complexes, transportation links and terminals, etc. The size of such indivisible units is normally predetermined in a nonspatial microeconomic analysis in this case.

The constraints for the planning problem are:

1. The amount of land in each zone, which should not be planned to be used beyond a certain maximum congestion point.

2. The planned level of production for each sector of Silistra as a whole should be fulfilled. This means that the macroeconomic planning goals should not be violated by the physical planning process.
3. The construction sector production capacity localized to the Silistra region as a whole should not be overused.
4. Restructuring of areas should not go faster than is economically reasonable.

These general constraints can be formalized into quantitative mathematical constraints:

$$1. \quad \sum_{jt} \lambda_{jt} x_{jt}^r \leq L^r \quad j \quad (r = 1, \dots, 2)$$

where

$\lambda_{jt}$  = coefficient of use of land per unit of production in sector  $j$  at time period  $t$

$x_{jt}^r$  = capacity of production of sector  $j$  in zone  $r$  at time period  $t$

$L^r$  = amount of economically usable land of zone  $r$ .

$$2. \quad \sum_r x_{it}^r = X_{it} \quad ;$$

where

$X_{it}$  = total production in Silistra of commodity  $i$  in time period  $t$

$$3. \quad \sum_{r,j} \beta_j^r (x_{j,t}^r - x_{j,t-1}^r) \leq C_t - \beta_r (\tau_t - \tau_{t-1})$$

where

$\beta_j^r$  = use of construction capacity per unit of new production capacity of sector j in zone r

$C_t$  = total construction capacity for the Silistra region in time period t

$\beta_r$  = use of construction capacity per unit of new transportation capacity

$\tau_t$  = transportation capacity in time period t.

$$4. \quad X_{jt}^r \geq \delta_j^r X_{j,t-1}^r ; \quad 0 < \delta_j < 1$$

$1 - \delta_j$  = rate of depreciation of production capacity sector j in zone r.

This set of constraints should be applied to a set of at least 10 zones, 5 aggregated sectors and 3 time periods. Using  $X_{i,t}^r$  as the fundamental variable the number of combinatorial variables should not be less than 150 implying a large combinatorial problem.

It is obvious that solutions to this problem can only be found with some optimality criterion. We suggest that a weighted sum of transportation, investment, and environmental costs be used as an objective to be minimized through variations in the  $\{X_i^r\}$  vector.

In the short term, when most of the spatial allocation pattern is given, it is often safe to assume the transportation cost to be linear. In the long run the linearity approach is not admissible. It is impossible in the long run of 20-30 years to plan exactly the location of the most efficient input-producers and households of certain types. If the focus is to create robust regions for the very long run it is much more reasonable to incorporate accessibility ideas into nonlinear transportation cost functions of the following form:

Expected cost of contact for one unit of production  $i$  if located in zone  $r$  for input of type  $j$ :

$$= \sum_s c_i a_{ij}^S d_{rs}(\tau_r) (x_j^S / \sum_s x_j^S) ,$$

where

- $\{a_{ij}^S\}$  = the input-output coefficients for the Silistra region;
- $c_i$  = transportation capacity use per unit of trade; and
- $\tau_r$  = transportation network characteristics from zone  $r$ .

Aggregating, we get the following expected total cost of contacts:

$$\sum_{rs} x_i^r c_i a_{ij}^S d_{rs}(\tau_r) x_j^S = x^T K x ,$$

which is a quadratic potential transportation cost function.

Investment costs may be represented linearly with respect to the increases in production as long as the physical planning problem is formulated in a combinatorial way. (With a reformulation in continuous variables, the average investment cost must fall with increasing scale of production.)

Investment costs would consequently be of the following form in the integer programming version:

$$\text{Investment costs} = \sum_{r,i} b_i^r (x_{it}^r - x_{i,t-1}^r) .$$

Environmental costs are evidently much harder to estimate but it is nevertheless proposed that they be included in the evaluation function. The representation of environmental costs must obviously include "synergisms." This precludes the use of a linear environmental cost function. The simplest representation would be with the quadratic form.

$$\text{Environmental costs} = \sum_{r,i,j} x_{it}^r e_{ij} x_{jt}^r$$

The interpretation is the following:

Assume that sector  $i$  is heavy industry and  $j$  is housing. A positive  $e_{ij}$  would then indicate that co-location of these activities would increase environmental costs.

Summarizing, the model for integrated physical and economic planning has the following general structure:

Minimize :	Transportation costs + Investments costs + Environmental costs
subject to constraints on:	Land availability production requirements construction capacity depreciation possibilities integer-valued changes of the location variables.

The programming of this model is a task of considerable mathematical complexity and it will probably require certain modification to be adaptable to currently available solution methods. A group of scientists consisting of Dr. Killio of SDS, and scholars from Regional Development and KNIPITUGA should be formed to investigate these issues.

#### ECONOMIC MODELS OF INTERREGIONAL MIGRATION

Migration is important at the regional level because of its effect on the size and structure of the population; it produces faster changes than purely natural birth and death processes. Therefore, migration will yield changes in consumption, in saving, in investment, and in government expenditure patterns as the size and structure of the population vary. Moreover, migration has proved to influence (and to be influenced by) labor markets, wage levels, housing situations, and capital

investments. [See, for instance, Karlqvist and Snickars (1977), Kulikowski (1978), Cooper and Schinnar (1973).]

Therefore, it seems obvious that a study of migration cannot be limited to its purely demographic terms, but should be extended to cover the main links with the economic and social processes [See Bilsborrow (1976), Willekens and Rogers (1977) for review and extensive bibliographies of the literature on this subject.]

This section is mainly based on the theory developed in Arcangeli and La Bella (1978); its aim is that of proposing a general economic model of the interregional migration process consistent with a framework of models of the economic processes and of the interregional interactions. In the first part of this section, starting from a microeconomic foundation, we develop a general migration model based on the analysis of economic determinants, and discuss several different versions. In the second part, we shall discuss the applicability of the model to the Silistra Case Study.

#### *A Microeconomic Approach*

In the analysis of the economic determinants of interregional migration flows, models tend to be primarily based upon one of the following three different theories (Greenwood 1975, Hart 1975b, La Bella and Venanzoni 1978, Arora 1974, Andersson and Holmberg 1976).

- the microeconomic consumer's theory (Hicks 1932);
- the microeconomic human capital theory (Schultz 1961, Becker 1962); and
- the macroeconomic interdependency theory (Andersson and Holmberg 1976).

It is not the purpose of this section to review the above theories, and the interested reader is referred to the literature. We shall give some details only about the human capital theory, on which the analysis carried out in this



section is based, which, as applied to the explanation of the migration phenomenon, leads to the following basic hypothesis:

Hypotheses 1: The decision of moving for an individual is based on a rational comparison between the expected costs and benefits of the move. Costs and benefits are computed for the expected duration of life and discounted to their present value.

As it is obvious, costs and benefits must be intended in the broad sense, including both monetary and nonmonetary elements. For instance, the costs should include the direct monetary cost associated with the move, the indirect monetary costs as earnings foregone while traveling, searching for and having a new job, and the psychological cost of moving.

Therefore, for an individual of age  $x$ , the present value of the move from region  $i$  to region  $j$  can be formulated as:

$$PV_{ij}^x(t) = \sum_{s=t}^{L_x(t)} \frac{R_j(s) - R_i(s)}{(1+r)^{s-t}} - \sum_{s=t}^{L_x(t)} \frac{C_j(s) - C_i(s)}{(1+r)^{s-t}} - \gamma_{ij} \quad , \quad (1)$$

where:

PV = expected value of the move,

R = expected income,

C = expected cost of living,

$\gamma$  = fixed cost of the move,

r = discount factor,

$L_x(t)$  = subjective expected duration of life for individuals of age  $x$  at time  $t$ .

The decision-making process for an individual can be represented by a function:

$$D(PV_{ij}^X) = \begin{cases} 1 & \text{if } PV_{ij}^X > 0 \\ 0 & \text{if } PV_{ij}^X \leq 0 \end{cases}, \quad (2)$$

where  $D = 1$  represents the decision of moving.

The formulation (1), (2) of the "decision of migrating" process assumes a deterministic environment and a full information situation. A more realistic model should take into account the differential probability of finding a job in region  $i$  and  $j$ , and the information available to the potential migrants. Therefore, equation (1) could be modified as follows:

$$PV_{ij}^X(t) = \sum_{s=t}^{L_X(t)} \frac{R_j(s) - R_i(s)}{(1+r)^{s-t}} L_{ij}(s) + \\ - \sum_{s=t}^{L_X(t)} \frac{C_j(s) - C_i(s)}{(1+r)^{s-t}} - \gamma_{ij}, \quad (3)$$

where  $L_{ij}(s)$  is an indicator of the differential situation of local labor markets.

Also, the decision function (2) should be modified in order to represent a probability distribution as a function of  $PV_{ij}^X(t)$  and  $L_{ij}(s)$ .

In this framework, it appears to be convenient to use an aggregate function of propensity to migrate, defined as the per capita net loss of population of region  $i$  with respect to region  $j$ :

$$q_{ij}^X(t) = \frac{M_{ij}^X(t) - M_{ji}^X(t)}{P_i^X(t)}, \quad (4)$$

where:

- $P_i^x$  = population of region i in the  $x^{\text{th}}$  age group,
- $M_{ij}^x$  = migrants from region i to region j in the  $x^{\text{th}}$  age group,
- $q_{ij}^x$  = propensity to migrate from region i to region j for individuals of age x.

We can also define the propensity to migrate from region i as:

$$q_i^x(t) = \sum_{j \neq i} q_{ij}^x(t) \quad (5)$$

Assuming constant, even if different, rates of growth of income and cost, one can expect  $q_{ij}^x(t)$  to be a function of the current and estimated future differentials between region i and region j:

$$q_{ij}^x(t) = q(x, \Delta R_{ij}, \Delta C_{ij}, \Delta h_{ij}^R, \Delta h_{ij}^C, r, L_{ij}, \gamma_{ij}), \quad (6)$$

where:

- $\Delta R_{ij}, \Delta C_{ij}$  = current differentials in benefits and costs,
- $\Delta h_{ij}^R, \Delta h_{ij}^C$  = expected differentials in rates of growth of income and cost of living.

Some authors (Hart 1975 a, Frick and La Bella 1977), have emphasized the need to accommodate in the model a response lag of potential migrants to economic stimuli, in order to distinguish the steady-state migration flows from the transient behavior of the population.

In order to take this point into account, we can postulate the following adjustment scheme:

$$\tilde{q}_{ij}^x(t+1) - \tilde{q}_{ij}^x(t) = \frac{1}{\tau_x} [q_{ij}^x(t) - \tilde{q}_{ij}^x(t)] \quad , \quad (7)$$

where  $\tau_x$  is a time constant, which might be expected to vary according to age of migrants, and  $\tilde{q}_{ij}^x(t)$  is the actual value of the propensity to migrate. It is easy to see that in steady-state conditions:

$$\tilde{q}_{ij}^x(t) = q_{ij}^x(t) \quad .$$

For simplicity we consider a two-region system and an age-aggregated function of propensity to migrate, and we drop the unnecessary indices. Equation (7) can be written in continuous form as:

$$\dot{\tilde{q}}(t) = \frac{1}{\tau} [q(t) - \tilde{q}(t)] \quad .$$

We multiply for the population size in region i,

$$\dot{M}(t) = aM(t) + b(t) \quad , \quad (8)$$

where

$$a = -\frac{1}{\tau} \quad , \quad b(t) = \frac{1}{\tau} q(t)P(t) \quad .$$

Some interesting considerations on other possible ways of representing the migration phenomenon can be drawn considering the following stochastic counterpart of equation (8):

$$dM_t = [a_1 M_t + b_1(t)] dt + [a_2 M_t + b_2(t)] dW_t \quad , \quad (9)$$

where  $W_t$  is a Wiener process and  $b_1, b_2$  are exogenous variables. A closed form solution for the inhomogeneous equation (9) can be expressed (Frick 1976) in the form:

$$M_t = \phi_t M_0 + \phi_t \int_{t_0}^t \phi_s^{-1} b_1(s) ds + \phi_t \int_{t_0}^t \phi_s^{-1} b_2(s) dW_s \quad ,$$

where  $\phi_t$  is the solution to the homogeneous equation.

$$d\phi_t = a_1 \phi_t dt + a_2 \phi_t dW_2$$

$$\phi_{t_0} = 1$$

given by:

$$\phi_t = \exp \left\{ \left( a_1 - \frac{1}{2} a_2^2 \right) (t - t_0) + a_2 (W_t - W_0) \right\} .$$

It is very well known that under certain continuity assumptions (Arnold 1974), these solutions  $M_t$  are also the solutions of a diffusion process with coefficients (Frick and La Bella 1977):

$$\beta(t, m) = a_1 m + b_1(t) \quad \text{drift} \quad (10)$$

$$\alpha(t, m) = [a_2 m + b_2(t)]^2 \quad \text{diffusion} \quad (11)$$

Moreover, it is very well known that, under not very restrictive assumptions (Frick 1976), a diffusion process with parameters  $\beta(t, m)$  and  $\alpha(t, m)$  has a continuous chain equivalent specified in terms of a birth-death process with parameters  $\gamma_m$  and  $\mu_m$  satisfying:

$$\beta(t, m) = \gamma_m(t) - \mu_m(t) \quad , \quad (12)$$

$$\alpha(t, m) = \gamma_m(t) - \mu_m(t) \quad . \quad (13)$$

When applied to our case, (10-13) provide another possible representation of the migration phenomenon seen as a stochastic birth and death process with parameters:

$$\gamma_m(t) = \frac{1}{2} [b_1 + b_2^2(t)] + \frac{1}{2} [a_1 + a_2^2 m + 2a_2 b_2(t)] m \quad (14)$$

$$\mu_m(t) = \frac{1}{2} [b_1 + b_2^2(t)] + \frac{1}{2} [a_1 - a_2^2 m - 2a_2 b_2(t)] m$$

Equations (6), (7), (8), (9), and (14) supply different representations of the migration process, viewed in relationship with its economic determinants at different levels of complexity and simplicity of implementation.

*Quantification of Variables and Implementation*

Even if the approach followed so far can be considered of general validity, one can expect that the form of the function of propensity to migrate and the quantification of the explanatory variables differ significantly when passing from a market-economy to a planned-economy framework. Moreover, it is evident that the sensitivity of the population to the many economic factors which determine the migration phenomena can be established only after careful statistical testing.

However, it is possible to formulate an "a priori" list of factors which may affect the costs and benefits of the move and, therefore, the decision to migrate in countries with centrally-planned economies:

- structure of employment in the different regions, and wage differentials among different sectors within regions;
- spatial differentials in the degree of urbanization; in location of social services and infrastructure, etc.;
- spatial differentials in availability and quality of housing facilities; and
- interregional distance (according to one of the possible measures).

In the first experiments, we shall restrict ourselves to consider two simple specifications of the aggregate propensity-to-migrate function (6), disregarding the influence of age. The first specification will be a linear one:

$$q_{ij}(t) = a + \sum_h b_h u_{ij}^h(t) \quad (15)$$

where  $q_{ij}(t)$  is defined according to (4), and  $\{u_{ij}^h(t)\}$  is the set of indicators of the differences between region  $i$  and region  $j$ . The second specification will have the form of a constant-elasticity function, such as

$$q_{ij}(t) = \alpha \prod_h [u_{ij}^h(t)]^{\beta_h} \quad (16)$$

The two above specifications will be tested and compared.

A first formulation of the set of indicators  $u_{ij}^h(t)$ , according to the above considerations, may be the following:

$$u_{ij}^1 = \frac{\sum_k E_j^k W_j}{P_j} \Big/ \frac{\sum_k E_i^k W_i}{P_i} \quad (17)$$

$$u_{ij}^2 = \frac{\sum_k E_j^k v_j^k}{L_j} \Big/ \frac{\sum_k E_i^k v_i^k}{L_i} \quad (18)$$

$$u_{ij}^3 = f(H_i, H_j) \quad (19)$$

$u_{ij}^4$  - distance between regions  $i$  and  $j$  ,

where:

$E_j^k$  = employment in sector k of region j

$P_j$  = population size of region j

$W_j^k$  = wage level in sector k of region j (or other measure of the preference of workers)

$v_j^k$  = quantification of social utility of services (i.e.,  $v=0$  for nonservice sector,  $v=1$  for educational opportunities) as perceived by the population

$H_j$  = indicator of housing situation in region j

$L_i$  = labor force in region i.

As is obvious,  $u^3$  is the indicator most closely related to the cost component of the function of propensity to migrate. There is a very well-established opinion that such a component should be dependent on the differential housing situation, but its quantitative formulation can differ significantly from case to case because of both structural differences and the availability of different data based on housing. As an example of a possible formulation, we may have:

$$u_{ij}^3(t) = \frac{\Delta H_j(t)}{M_j(t)} \bigg/ \frac{\Delta H_i(t)}{M_i(t)}, \quad (20)$$

where:

$\Delta H_j(t)$  = construction of new houses in region j during the period t

$M_j(t)$  = number of marriages in region j during the period t.

The models introduced so far can be estimated using econometric techniques on the basis of:



- time series data,
- cross-section data,
- mixed time series and cross-section data.

A first test of models (15) and (16) would require the following data:

1. Origin destination table for migrants (for the regions mentioned above);
2. Population size in each region;
3. Employment by sectors in each region;
4. Excess demand for labor by sector in each region;
5. Wage levels in the different sectors in the above regions;
6. Average distance among the above main cities of those regions can be used);
7. Housing construction in each region per year; and
8. Number of marriages per year in each region.

All data should be supplied in the form of yearly time series, as long as possible.

Once the model has been estimated, it would be used for simulation experiments, both alone and in connection with the models of the other components of the regional system.

#### MODELING THE COMMUTING PROCESS

Commuting is the other aspect of population mobility. Like migration, it arises when individuals seek satisfaction of their needs outside the borders of their place of residence, and it is usually dominated by labor markets and housing differentials; unlike migration, it is normally limited to short-distance movements. The distinction between migration and commuting is, however, quite blurred. An analysis of the relationships between these two phenomena is beyond the aim of this section, and can be found, together with a classification of the possible types of population mobility, in Andersson and Holmberg (1976).

Here we restrict ourselves to the consideration of the commuting trips between residence and work-place, and present two modeling approaches: the first approach is a normative one to calculate the economically optimal commuting pattern; the second approach, based on an entropy maximization procedure, is for forecasting the actual commuting pattern resulting from a given distribution of residences and work-places.

A common framework is constituted by the consideration of  $n$  settlements, among which people are allowed to commute,  $m$  economic sectors, and the following sets of constraints:

$$\sum_j T_{ijh} = L_{ih} \quad , \quad \forall i,h \quad , \quad (21)$$

$$\sum_i T_{ijh} \leq D_{jh} \quad \forall i,h \quad , \quad (22)$$

where:\*

$D_{jh}$ : labor demand in region  $j$  and sector  $h$

$L_{ih}$ : labor supply in region  $i$  and sector  $h$

$T_{ijh}$ : commuters from region  $i$  to region  $j$  in sector  $h$ .

We assume here that  $L_{ih}$  is a function of the relative housing situation of settlement  $i$  with respect to the average housing level for workers in sector  $h$ . Moreover,  $D_{jh}$  will be considered dependent on the capital stock installed in settlement  $j$  and sector  $h$ . Therefore, we have:

---

\*Note that (21) and (22) implicitly state that

$$\sum_i L_{ih} \leq \sum_j D_{jh} \quad ;$$

i.e., that integrating over all regions, the global labor demand is not less than the global labor supply.

$$L_{ih} = L_{ih}(H_{ih}, H_h) \quad , \quad (23)$$

$$D_{jh} = D_{jh}(K_{jh}) \quad , \quad (24)$$

where

$H_{ih}$ : indicator of housing availability and quality in settlement  $i$  for workers in sector  $h$ ,

$H_h$ : indicator of average housing availability and quality for workers in sector  $h$ .

We now tackle the following problem. With a given distribution of population and capital over the  $n$  settlements and the  $m$  sectors, what would be the economically optimal pattern of commuting? It must be noticed that in this formulation of the problem we assume  $H_{ih}$ ,  $H_h$ , and  $K_{jh}$  in (23) and (24) as fixed for all  $i, j$ , and  $h$ .

A solution to the above problem can be obtained with the use of a Cobb-Douglas production function for each sector and settlement:

$$Y_{jh} = A_{jh} K_{jh}^{\alpha_{jh}} \left( \sum_i T_{ij} \right)^{\beta_{jh}} \quad , \quad (25)$$

where

$Y_{jh}$ : output of sector  $h$  in settlement  $j$  ,

$A_{jh}$ : constant ,

$\alpha_{jh}$ ,  $\beta_{jh}$ : positive parameters .

We can now specify the total production as

$$Y_{**} = \sum_j \sum_h A_{jh}^{\alpha_{jh}} K_{jh}^{\beta_{jh}} \left( \sum_i T_{ij} \right)^{\beta_{jh}} \quad , \quad (26)$$

and therefore, the optimal pattern of commuting may be obtained by solving the following problem:

$$\begin{aligned} \max Y_{**} \\ \text{s.t. (21) and (22) .} \end{aligned} \quad (27)$$

The purpose of the second approach is to calculate the most probable pattern of commuting consequent to a given distribution of residences and working places. It is obvious that the pattern calculated in this way can be significantly different from that obtained as the solution of problem (27).

We recall that the most probable distribution of commuting trips compatible with constraints (21) and (22) can be found by maximizing the so-called entropy function given as

$$W = - \sum_i \sum_j \sum_h [T_{ijh} \ln T_{ijh} - T_{ijh}] \quad (28)$$

subject to (21) and (22). For calibration purposes only, the method requires a further set of constraints of the following kind

$$\sum_i \sum_j T_{ijh} c_{ijh} = C_h \quad , \quad (29)$$

where  $c_{ijh}$  is the cost of the individual commuting trip, and  $C_h$  poses an upper constraint on the total travel expenses for each category of commuters. A complete discussion of the use of entropy maximizing techniques can be found in Snickars and Weibull (1977) and Willekens, Por, and Raquillet (1978).

We can associate to the entropy maximization problem the following Lagrangean:

$$\begin{aligned} \max_{\{T_{ijh}\}} : L = W + \sum_i \sum_h \gamma_{ih} [L_{ih} - \sum_j T_{ijh}] + \sum_j \sum_h \mu_{jh} [D_{jh} - \sum_i T_{ijh}] + \\ + \sum_h \nu_h [C_h - \sum_i \sum_j T_{ijh} c_{ijh}] \quad , \end{aligned}$$

with

$$\mu_{jh} \geq 0 \quad \text{and} \quad \mu_{jh} [D_{jh} - \sum_i T_{ijh}] = 0 \quad \forall j, h . \quad (30)$$

From the first-order conditions, we get

$$\frac{\partial L}{\partial T_{ijh}} = -\ln T_{ijh} - \gamma_{ih} - \mu_{jh} - \beta_h c_{ijh} = 0 ,$$

and therefore,

$$T_{ijh} = e^{-\lambda_{ih} - \mu_{jh} - \beta_h c_{ijh}} .$$

Posing

$$A_{ih} = \frac{e^{-\lambda_{ih}}}{L_{ih}} , \quad B_{jh} = \frac{e^{-\mu_{jh}}}{D_{jh}} ,$$

we obtain:

$$T_{ijh} = A_{ih} \times B_{jh} \times L_{jh} \times D_{jh} e^{-\beta_h c_{ijh}} , \quad (31)$$

substituting in (21), (22) and using (30), we get

$$A_{ih} = [\sum_j B_{jh} D_{jh} e^{-\beta_h c_{ijh}}]^{-1} ,$$

$$B_{jh} = \begin{cases} 1/D_{jh} & \text{if } D_{jh} > \sum_i T_{ijh} \\ [\sum_i A_{ih} L_{ih} e^{-\beta_h c_{ijh}}]^{-1} & \text{if } D_{jh} = \sum_i T_{ijh} , \end{cases}$$

which can be used for iteratively solving the entropy maximizing problem [see, for instance, Willekens (1977), and Willekens, Por and Raquillet (1978)!]. The parameter  $\beta_h$  represents the

sensitivity of the  $h^{\text{th}}$  category of commuters to the commuting cost and can be used for calibrating the model.

Let us now call  $\{T_{ij h}^*\}$  the optimal commuting pattern obtained as a solution of problem (27), and  $\{T_{ij h}^o\}$  the commuting pattern obtained as a solution of the entropy maximization problem. From the planning point of view, the question arises of how to influence the commuting behavior of the population represented by  $\{T_{ij h}^o\}$  in order to make it as close as possible to the optimal one. In this framework, three types of interventions can be envisaged; experiments can be done on the models with each intervention separately or in different combinations:

1. changes in the commuting costs; this type of intervention would include changes in the transportation prices and the wage levels in the different settlements and sectors;
2. intervention on the housing sector;
3. intervention in the labor demand through investments in the various sectors and settlements.

It should be noticed that the changes in the commuting costs would only affect  $\{T_{ij h}^o\}$ , and would be very easy to compute once the parameters  $\beta_h$  are known. Instead, the other two types of intervention would influence both  $\{T_{ij h}^o\}$  and  $\{T_{ij h}^*\}$ .

Therefore, for planning purposes, a delicate problem of coordination of the two models arises. A scheme of the interaction between the two models and their place in a planning procedure is given in Figure 9.

As a concluding remark, we would like to point out that there are many possible generalizations of the above two models. The most important is the possibility of adding further constraints to the normative model in order to take into account specific planning requirements for deriving the optimal commuting pattern. For example, it can be required that the workers in agriculture in a given settlement  $h$  be not less than a specified number  $N_{ha}$ . In that case an addition to (21) and (22) of the following constraint would be sufficient:

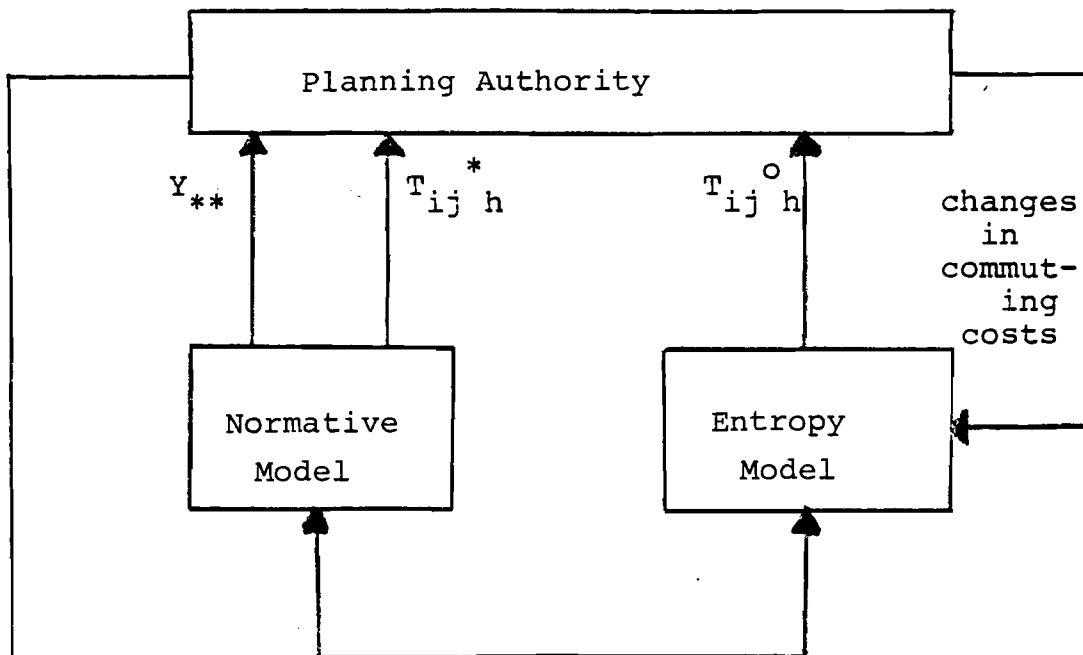

housing and investment planning

Figure 9. Planning and behavior.

$$\sum T_{iha} \geq N_{ha} ,$$

where a stands for agricultural sector.

REFERENCES

- Andersson, A.E. (1975) A Closed Nonlinear Growth Model for International and Interregional Trade and Location. *Regional Science and Urban Economics* 5.
- Andersson, A.E., and I. Holmberg (1976) Net and Gross Migration Analysis, in *Competition Among Small Regions*, edited by W. Bulir and P. Friedrich, Nomos Verlagsgesellschaft. Baden-Baden.
- Arcangeli, R., and A. La Bella (1978) Factors Mobility and Regional Development Policies, Paper presented at the Notec Regional Development Task Force Meeting II, Jablonna, Poland, September 12-15.
- Arnold, L. (1974) *Stochastic Differential Equations: Theory and Applications*. New York: J. Wiley and Sons.
- Arora, S.S. (1974) *Migration Flows and Their Determinants: A Comparative Study of Internal Migration in Italy and USA*. Working Paper No.26, National Bureau of Economic Research, Inc., Cambridge.
- Becker, G.S. (1962) Investment in Human Capital: A Theoretical Analysis. *Journal of Political Economy*, Supplement, Part 2, October.
- Bilsborrow, R.E. (1976) *Population in Development Planning: Background and Bibliography*. University of North Carolina at Chapel Hill, Laboratories for Population Statistics-- Technical Information Services, Chapel, North Carolina.
- Brody, A. (1970) *Proportions, Prices and Planning*. Amsterdam.



- Cassel, G. (1917) *Theory of Social Economy*, (translation from the German edition 1917). New York 1932.
- Cooper, W.W., and A.P. Schinnar (1973) *A Model for Demographic Mobility Analysis under Patterns of Efficient Employment*. *Economics of Planning* 13(3):139-173.
- Frick, P.A. (1976) *A Study of Stochastic Bilinear Systems as They Relate to an Economic Modeling Situation--The Scalar Case*. Research Report R.76-21. Centro di Studio dei Sistemi di Controllo e Calcolo Automatici. Rome.
- Frick, P.A., and A. La Bella (1977) *Models of Spatial Population Dynamics in Italy*. Research Report R.77-01. Centro di Studio dei Sistemi di Controllo e Calcolo Automatici. Rome.
- Greenwood, M.J. (1975) *Research on Internal Migration in the United States: A Survey*. *Journal of Economic Literature* 13(2), June.
- Hägerstrand, T. (1970) *Tidsanvändning och Omgivningsstruktur*, SOU 1970:14.
- Hahn, H. (1974) *Geometrical Aspects of the Pseudo Steady State Hypothesis in Enzyme Reactions*. Tübingen.
- Hart, R.A. (1975a) *Interregional Economic Migration: Some Theoretical Considerations (Part II)*. *Journal of Regional Science* 15(3):289-305.
- Hicks, J.R. (1932) *The Theory of Wages*. London: MacMillan.
- Karlqvist, A., and F. Snickars (1977) *Regional Migration and Labour Markets*, in *Demographic Economic and Social Interaction*, edited by A.E. Andersson and I. Holmberg:233-266. Boston: Ballinger.
- Kornai J. (1970) *Anti-equilibrium*. Amsterdam.
- Kulikowski, R. (1978) *Optimization of Rural-Urban Development and Migration*. *Environment and Planning A* 10:577-591.
- La Bella, A., and G. Venanzoni (1978) *Economic Determinants of Population Mobility in Italy*. *Proceedings of Airo Conference, Urbino, Italy (in Italian)*.
- Lancaster K. (1966) *A new approach to consumer theory*. *Journal of Political Economy* 74.
- Lefebvre, L. (1958) *Allocation in space*. Amsterdam.
- Lefkowitz, I. *Multilevel Approach Applied to Control System Design*. *Trans. ASME* 88 D(2) 1966.
- Mees, A.L. (1975) *The revival of cities in medieval Europe*. *Regional Science and Urban Economics* 5(4).

- Mesarovic, M.D., D. Macko, and Y. Takahara (1970) Theory of Hierarchical, Multilevel Systems. New York: Academic Press.
- Mesarovic, M.D., and Y. Takahara (1975) General Systems Theory: Mathematical Foundations. New York: Academic Press.
- Morishima M., and T. Fujimotor. The Frobenius Theorem, Its Solow-Samuelson Extension and the Kuhn-Tucker Theorem. Journal of Mathematical Economics 1.
- Morishima M. (1959) The Problem of Intrinsic Complementarity and Separability of Goods. Metro-economica 11.
- Nijkamp, P. (1975) Reflections on gravity and entropy models. Regional Science and Urban Economics 5(4).
- Nikaido, H. (1968) Convex Structures and Economic Theory. New York.
- Radner, R. (1975) Satisficing. Journal of Mathematical Economics 2.
- Sanderson, W.C. (1974) Does the Theory of Demand Need the Maximum Principle? in Nations and Households in Economic Growth, Essays in honor of Moses Abramovitz, edited by P.A. David and M.W. Reder.
- Schultz, T.W. (1961) Investment in Human Capital. American Economic Review 51(1).
- Scitovsky, T (1976) The Joyless Economy. New York.
- Simon, H.A. (1972) Theories of Bounded Rationality, in Decision and Organization, edited by C.B. McGuire and R. Radner. Amsterdam.
- Snickars, F., and J.W. Weibull (1977) A Minimum Information Principle: Theory and Practice. Regional Science and Urban Economics 7:137-168.
- Usher, D. (1977) Public Property and the Effect of Migration Upon Other Residents of the Migrants' Countries of Origin and Destination. Journal of Political Economy 85(5): 1001-1020.
- Wald, A. (1951) On Some Systems of Equations of Mathematical Economics. Econometrica 19.
- Weibull, J. (1977) unpublished Manuscript.
- Willekens, F. (1977) The Recovery of Detailed Migration Patterns from Aggregate Data: An Entropy Maximization Approach. RM-77-58. Laxenburg, Austria: International Institute for Applied Systems Analysis.

Willekens, F., and A. Rogers. (1977) Normative Modelling in Demo-Economics. RR-77-23. Laxenburg, Austria: International Institute for Applied Systems Analysis. December

Willekens, F., A. Por, and R. Raquillet (1978) Entropy and Multi-proportioned Techniques for Inferring Detailed Migration Patterns from Aggregated Data. Conference on Analysis of Multiregional Population Systems: Techniques and Applications. Laxenburg, Austria: International Institute for Applied Systems Analysis. September 19 - 22.

AN INFORMATION RETRIEVAL AND ANALYSIS SYSTEM:  
THE INTERFACE BETWEEN THE OBJECT OF STUDY  
AND THE SYSTEM OF MODELS

K. Evtimov, N. Grigorov  
and D. Kebedjiev

The research activities for the analysis and development of the Silistra region require the collection, systematization, and processing of enormous information blocks. Due to the complexity of the region, the fulfillment of such a task is impossible by means of traditional methods, hence the necessity of creating an information retrieval and analysis system, whose basic purpose is to provide information for the object of the study.

When developing the information system for the purposes of territorial organization, one should consider the following main requirements:

a) The information system data base must comprise all the information necessary for territorial organization in all its aspects. That involves the possibility of systematizing a large number of primary parameters in relevant groups, corresponding to the separate subsystems for territorial formation and organization. At the same time, the number of parameters should be allowed to grow continuously, as the information analysis

grows. Those parameters may be gradually aggregated into various data banks, each corresponding to the three levels of territorial organization: region, settlement system, and settlement.

b) The second main requirement concerns processing scope and variability of information system analysis. The system must provide information retrieval unrestricted in depth and scope for an arbitrary number of parameters, freely chosen from the separate data banks and generating the secondary parameters often used in practice. That presupposes a possibility for the user of the information system to define new parameters by means of freely set arithmetic expressions, in which the primary parameters introduced into the data bank are arguments.

c) The last requirement involves simplicity in using the information system. Nonspecialists in computers and programming should be able to operate the information system easily, and after only a brief introduction.

After fulfilling those three requirements, the information system and its data base will become a unifying information base for the system of models for territorial planning. In this respect, the information system is considered as an open system which is in a process of development, and in which the volume and the type of information as well as the number of methods for analysis increase.

#### INFORMATION SECTION

The basic principle of information object structuring is the functional-spatial one. The primary data are collected through inquiries and statistics. They are directly connected with the spatial organization of the environment and are assigned to each settlement in the region. On such a basis, a unified system of numerical indicators (coordinates) along the horizontal and the vertical rows of the scheme is created. The system corresponds to the conventional spatial identification of settlements in the Silistra region (116 in number). For the purpose of settlement data grouping into other territorial units

(settlement systems), the boundaries of those units are conventionally coded in the unified square system of the region.

Groups of parameters, 11 in this case, are composed according to their functional aspect. Those groups correspond to the following subsystems for territorial organization of the region: geographic conditions, economics, population, dwellings, public services, recreation, technical infrastructure, etc. The groups may be supplemented and developed without any restrictions because of the information system.

#### SOFTWARE SECTION

The system GRASP, created for the purposes of the National Geologic Service of the United States in 1975, was used as a basic model in the development of the information system for the Silistra region. That dialogue system was redesigned with a view to the main requirements for territorial planning information systems. A substantial change was made in the organization and structure of the data base files. The change allows the creation of a supplementary subsystem, which, with the information system operation, fulfills information updating in the data base in a dialogue.

Another important change concerns the increased possibilities for joining functionally different programs, written in FORTRAN with the information system. Such programs may be:

- methods for information analysis in the data base;
- programs for generating input parameters for mathematical models; and
- small models from the system, which may be available to the information system for direct use.

The system was repeatedly programmed with view to its application in computers without virtual core memory, such as in the minicomputers. That makes it easily transferable to various computer systems, eliminating the necessity of data base transportation.

In its present version, the information system may compile various data banks, including numerical text, and graphic information.

In order to take advantage of the system, the user must be acquainted with its "language", which is easy for nonspecialists. From the user's point of view, that language represents a simple and fast mechanism for obtaining information from the data base and analyzing it. The language itself consists of 12 commands, which may be logically divided into the following four groups:

Group 1:

command FILE: Selects the data base called for by the user for work.

command NAMES: Gives information about the parameters from the chosen bank.

command DEFINITION: Allows the user to define new parameters by means of arithmetic formulae.

Group 2:

command LIST: Supplies data according to selected parameters from various data banks.

command DUMP: Operates like the LIST command, but for whole groups of parameters.

command FUNCTIONS: Fulfills the indicated programs included in the information system for arbitrarily chosen data.

Group 3:

command CONDITIONS: Accepts conditions of various parameters for information retrieval.

command LOGIC: Accepts a logical expression for information retrieval, consisting of conditions and their logical operations.

command SEARCH: Accomplishes information retrieval in the data bank, as indicated by the user.

Group 4:

command HELP: Gives brief information about the information system language.

command REVIEW: Gives information about the work done with the information system up to that moment.

command QUIT: Concludes operation with the system.

#### HARDWARE SECTION

The system was designed for the minicomputer NOVA 840, manufactured by DATA GENERAL, and later, for the computer system RC 4000 and the minicomputer RC 3600, both manufactured by the Danish firm REGNECENTRALEN.

The base configuration, necessary for the information system operation, must possess a core memory of 32 KB, a magnetic disc of 2 MB, and a terminal, or a console for a dialogue with the system.

The output from the information system operation may be received both on the terminal and printing devices (printer or hardcopy), and as a file on a disc, later used for another processing.

The information system allows recording of the whole dialogue, which may be later printed for secondary use.

#### MATHEMATICAL SECTION

At the present stage, the information system includes the following five programs for analysis of the information from the Silistra region:

##### 1. ESTIMATIONS:

This program computes up to five potential estimations, each of them including up to 20 parameters, from the following formula:

$$x_j = \frac{\sum_i x_i p_i}{\sum_i p_i} ,$$

$j = 1 \div (5 = \text{the number of potential estimation});$



$$i = 1 \div 20 ,$$

$$0 < p_i < 1 ,$$

$x_i$ ;  $p_i$  = parameter and its weight coefficient participating in the estimation.

The program allows recursive estimates so that each estimate might include the previous one as a parameter.

## 2. DISPLAY:

This program uses coordinate data of settlements and settlement systems boundaries. It constructs a graphic image of the growth of a selected parameter. This growth is expressed (up to 10) in a chosen value interval.

The number of degrees and the subintervals, studied for their sake, are set by the user.

The printing of the image, received on the terminal screen, allows a fast and simple drawing and duplication of schemes.

## 3. GRAPH:

This program plots a linear graph of settlements on the terminal screen from a set parameter.

Here, it is again the user who sets the boundary of the indicated parameter interval. The graph is plotted across the screen, which makes it unrestricted in length. The information about the separate settlements is delivered in alphabetical order.

## 4. FIT:

The program computes the statistical relation for two different variables and gives the following results:

- deviation;
- slope;
- correlation coefficient; and
- number of nonempty (x,y) points.

5. MEAN:

The program computes statistical estimations of the first rank, for arbitrarily chosen parameters (up to 5).

The five programs may operate simultaneously by a call to the FUNCTION command.

CONCLUDING REMARKS

As a result of the system application, the following most important features were observed:

- rapid processing of enormous volumes of input data and minimal manpower waste;
- transferable data banks;
- analysis objectiveness, achieved by many mathematic methods; and
- possibility for a direct use of the information system results.

The above-mentioned features of the information system give us grounds to consider in the future operative connection ("interface") between the data base for the Silistra region and the developed system of models. This relation will be realized by the following major functions of the system:

- compilation of primary information in various data banks;
- generating secondary information;
- search and transfer of information towards the system of models; and
- information actualization in the shared data bank as a result from the system of models work.

Thus, by means of the information system, two information images of the territorial object under study--the Silistra region--will be formed. The first image is built by the primary real data, necessary for the total functioning of the system of models. The second image represents the result from the system work or its objective. It will be built by means of all real, unchanging, primary data for the region, plus the new parameters generated by the system of models which outline the future development of the region.

Being bound into a new data base, these two object images will grant the possibility of fulfilling comparisons and estimations for the outcome of the system of models.

The development of a common data base, a system of models, and the information system will represent a contemporary approach, which may be applied to research activities, and design and planning of the territorial development not only in the region of Silistra, but also for the other regions in the country.

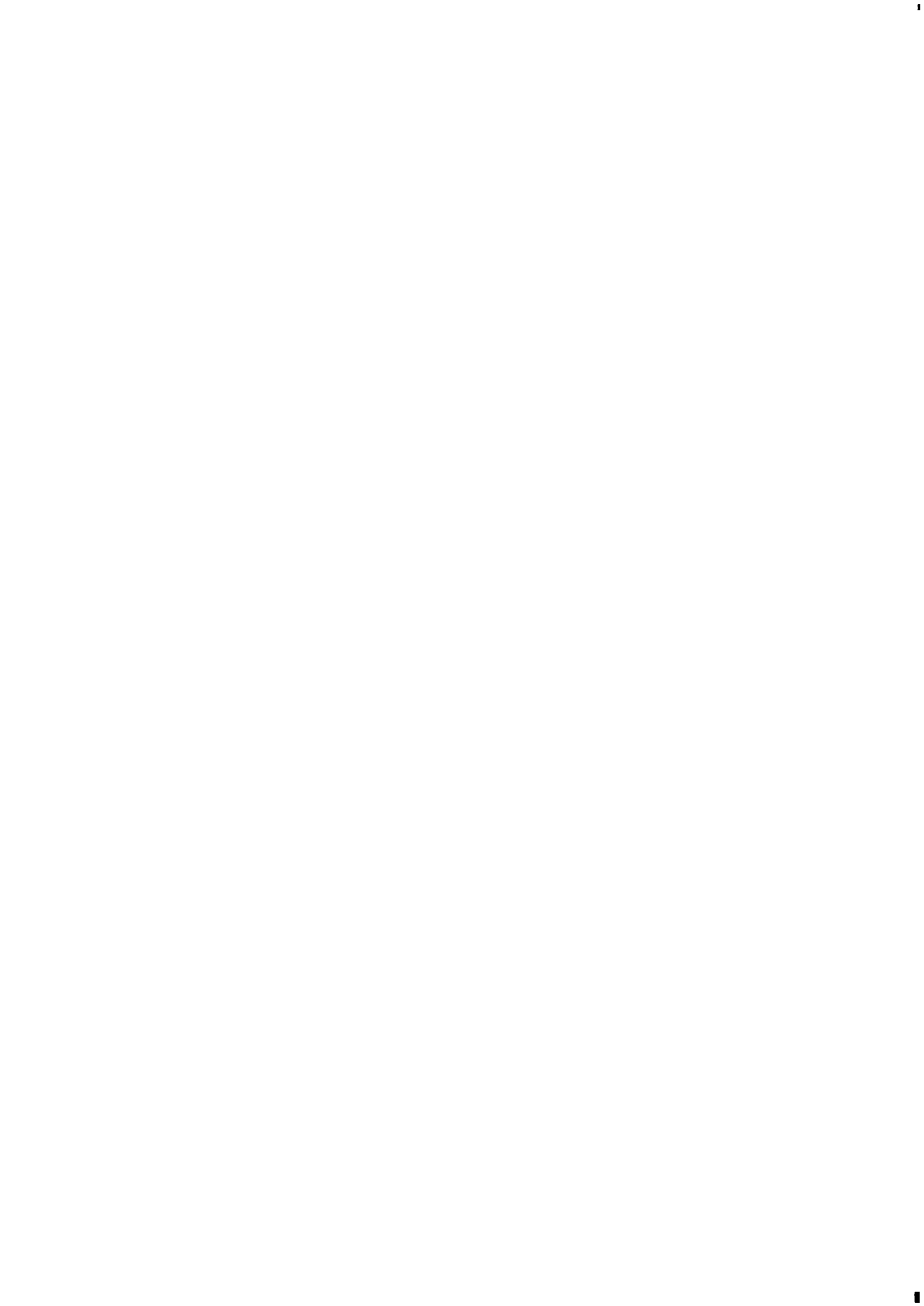

PART III

MODELING OF SUBSYSTEMS



ANALYSIS AND SIMULATED PROJECTIONS OF  
THE POPULATION OF THE SILISTRA REGION

Dimiter Philipov

One of the most important features of a contemporary complex analysis of regional development is the possibility of making any particular planned activity reasonable within the framework of the system approach. This comes about by multiple feedback between the separate models of the system, which may well cause substantial deviations from the expected results.

Depending on likely further repercussions within the system, a given line of action may even prove to be eventually self-defeating. In the opposite case, where desirable eventual effects can become much larger than those immediately following the action, the particular measures taken can have a catalytic effect (U.N., 1974, p. 103).

For instance, models which describe the development of industry, agriculture, physical planning, etc., are very often constructed without considering the amount of the classification of the labor force. If so, it may happen that, in order to meet the requirements of these models, the amount of labor in the region must rapidly increase. The regional population might not be able to ensure such an increase, so it becomes necessary to gain, through migration, from other regions.

It is obvious that the size of the migration flows, if not theoretically, are practically limited; therefore, it may well

happen that the regional requirements of the labor force, as predicted by the models, cannot be met at all. In such a case, the system of models will not be useful. Difficulties may arise also when the immigration flow is within its practical limits. The immigrants will need housing, education, health care services, transportation, etc., and if their number is considerable, some changes in the distribution of the investments will appear, which have not been accounted for by the models. In such a case, the line of action, as depicted by the models, is self-defeating.

The controversial point is met when there are fewer or more jobs than employees. If the planned regional development is a fast economic growth, ensured by an investment policy, one may expect that facilities may be available for the development of some additional activities in the region, in this way making it possible to speed still further the regional development. In such a case, the line of action as presented in the models will be catalytic.

From what has been stated above, it becomes clear that a system of models which does not incorporate studies on population, migration, and the labor force may be anything from self-defeating to catalytic. In order to avoid undesirable lines of action, it is necessary to link the different economic models with supplementary population studies, so that the linkage will describe the impact of population on economy, and vice versa.

In order to clarify this linkage, consider the following scheme:

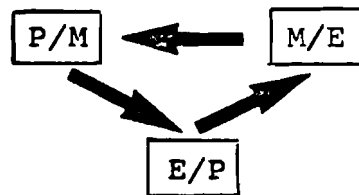

where P/M denotes those models where the population characteristics (age, sex, active population, etc.) are dependent on the migrations; M/E denotes the models which represent the migration movements as dependent on socioeconomic variables; and E/P



denotes the models which study the socioeconomic development of the region, as dependent on population (through the labor force, for instance).

The above-presented scheme does not consider the impact of socioeconomic changes on fertility and mortality, and vice versa. This is not necessary when the system of models is designed for a period of time not longer than 15 years.

In this report, the part P/M from the scheme will be considered. What is expected from it is to give a forecast of the population of the Silistra region, based on reasonable assumptions for the future trends of fertility, mortality, and migration.

The changes in fertility and mortality will be based on the demographic policy which is adopted in Bulgaria and its effectiveness in the Silistra region. The changes in migrations are based on the M/E models. For the time being, they are not available and will be replaced by descriptive scenarios.

The population projection and its simulations will be carried out and analyzed by making use of the multiregional demographic model which has been developed in IIASA and whose methodological basis is described by Rogers (1976). The study is carried out on the basis of the 1975 vital statistics data. The computer results are obtained through a package of computer programs created in IIASA (Willekens and Rogers 1978) and used for the study of the multiregional populations of all the member countries of the Institute.

#### ANALYSIS OF THE OBSERVED POPULATION

The multiregional approach to the study of population dynamics leads to the extension of the conventional demographic methodological tools: the single-region life table, the single-region population projection, the single-region stable equivalent population. The extension comes through the inclusion of the interregional migrations in the model, thus introducing the

spatial dimension into the population system. In the conventional case, the single-region population was closed to migrations, while in the extended case, a multiregional population is considered. Hence, methodological tools are provided for a more detailed study of the spatial population dynamics.

In the case of the Silistra region, the population is divided into two groups--Silistra natives and people from the rest of Bulgaria. The population data for 1975 are exhibited in Table 1.

Table 1. Observed population characteristics: input-data.

REGION SILISTRA					
AGE	POPULATION	BIRTHS	DEATHS	MIGRATION FROM SILISTRA TO SILISTRA R., OF, BUL	
0	14686.	0.	116.	0.	84.
5	15024.	0.	4.	0.	77.
10	12637.	4.	4.	0.	360.
15	17132.	539.	6.	0.	437.
20	15124.	1461.	10.	0.	170.
25	13753.	251.	16.	0.	66.
30	13784.	277.	17.	0.	55.
35	11979.	57.	19.	0.	31.
40	11842.	15.	30.	0.	21.
45	11577.	7.	43.	0.	14.
50	11592.	0.	22.	0.	10.
55	6707.	0.	76.	0.	5.
60	2613.	0.	160.	0.	5.
65	7166.	0.	235.	0.	4.
70	4091.	0.	259.	0.	3.
75	2621.	0.	262.	0.	2.
80	1193.	0.	191.	0.	1.
85	859.	0.	189.	0.	1.
TOTAL	176926.	3192.	1719.	0.	1374.

REGION PLOF, BUL					
AGE	POPULATION	BIRTHS	DEATHS	MIGRATION FROM PLOF, BUL TO SILISTRA R., OF, BUL	
0	652871.	2.	3834.	57.	0.
5	622246.	0.	316.	38.	0.
10	612498.	250.	270.	225.	0.
15	626311.	25149.	449.	270.	0.
20	640213.	65229.	607.	120.	0.
25	670307.	37960.	696.	97.	0.
30	643084.	11700.	725.	29.	0.
35	541814.	3539.	1706.	19.	0.
40	432208.	625.	1634.	7.	0.
45	401154.	70.	260.	5.	0.
50	341817.	0.	2181.	3.	0.
55	251140.	0.	2450.	3.	0.
60	170000.	0.	1900.	3.	0.
65	100000.	0.	1200.	1.	0.
70	70000.	0.	1000.	1.	0.
75	40000.	0.	1000.	1.	0.
80	20000.	0.	1000.	1.	0.
85	10000.	0.	1000.	1.	0.
TOTAL	6551037.	141837.	22000.	541.	0.

OBSERVED POPULATION CHARACTERISTICS

\*\*\*\*\*

INPUT-DATA

\*\*\*\*\*

REGION SILISTRA					
AGE	POPULATION	BIRTHS	DEATHS	MIGRATION FROM SILISTRA TO SILISTRA R.OF.BUL	
0	14686.	0.	110.	0.	84.
5	15096.	0.	4.	0.	77.
10	14657.	4.	4.	0.	360.
15	12182.	509.	6.	0.	437.
20	13126.	1461.	14.	0.	178.
25	13950.	861.	16.	0.	86.
30	13784.	277.	17.	0.	55.
35	11579.	57.	19.	0.	31.
40	11842.	16.	30.	0.	21.
45	11577.	7.	45.	0.	14.
50	11590.	0.	82.	0.	10.
55	6707.	0.	76.	0.	5.
60	8815.	0.	160.	0.	5.
65	7166.	0.	235.	0.	4.
70	4998.	0.	259.	0.	3.
75	2621.	0.	262.	0.	2.
80	1193.	0.	191.	0.	1.
85	859.	0.	189.	0.	1.
TOTAL	176428.	3192.	1719.	0.	1374.

REGION R.OF.BUL					
AGE	POPULATION	BIRTHS	DEATHS	MIGRATION FROM R.OF.BUL TO SILISTRA R.OF.BUL	
0	652871.	0.	3834.	57.	0.
5	622846.	0.	316.	38.	0.
10	612405.	234.	270.	225.	0.
15	626311.	23140.	449.	270.	0.
20	642213.	63820.	609.	120.	0.
25	676309.	37900.	696.	57.	0.
30	563856.	11786.	725.	29.	0.
35	551814.	3589.	1006.	19.	0.
40	622908.	898.	1628.	7.	0.
45	621155.	70.	2663.	5.	0.
50	603537.	0.	3981.	3.	0.
55	364560.	0.	3650.	3.	0.
60	440850.	0.	7678.	3.	0.
65	384096.	0.	11335.	1.	0.
70	277711.	0.	14248.	1.	0.
75	166260.	0.	14353.	1.	0.
80	73784.	0.	10461.	1.	0.
85	47851.	0.	10353.	1.	0.
TOTAL	8551337.	141437.	88255.	841.	0.

*Mean Ages*

The mean age of a population is an overall measure of its age-specific distribution. When the effect of the age distribution is eliminated, the mean age is a measure of the schedule of the observed characteristics, thus allowing for comparisons among different populations. Table 2 gives the mean ages of the population and of the schedules of fertility, mortality, and outmigration for Silistra and the rest of Bulgaria. For comparison, the same mean ages for the population of Sofia are added.

Table 2. Mean ages of the fertility, mortality, and outmigration schedules for three regions of Bulgaria.

Region	Population	Schedules of:		
		Fertility	Mortality	Out-migration
Silistra	33.60	24.21	78.58	20.44
Rest of Bul.	35.36	24.44	78.70	19.24
Sofia	34.37	25.44	80.04	27.20

Table 2 shows that the mean age of the Silistra population is low, which is due to its young mean age. Its schedules differ in a minor way from the schedules of the rest of Bulgaria. The differences are considerable when the highly urbanized region of Sofia is considered. Especially significant is the difference for the outmigration schedule.

The outmigration schedule of the Silistra population is exhibited in Figure 1. It can be seen that there is a high peak in the age group 15-20. This is due to the fact that in Bulgaria the pupils, upon finishing their primary education, have the choice of continuing their studies in a number of professional schools.

# OUT-MIGRATION SCHEDULE

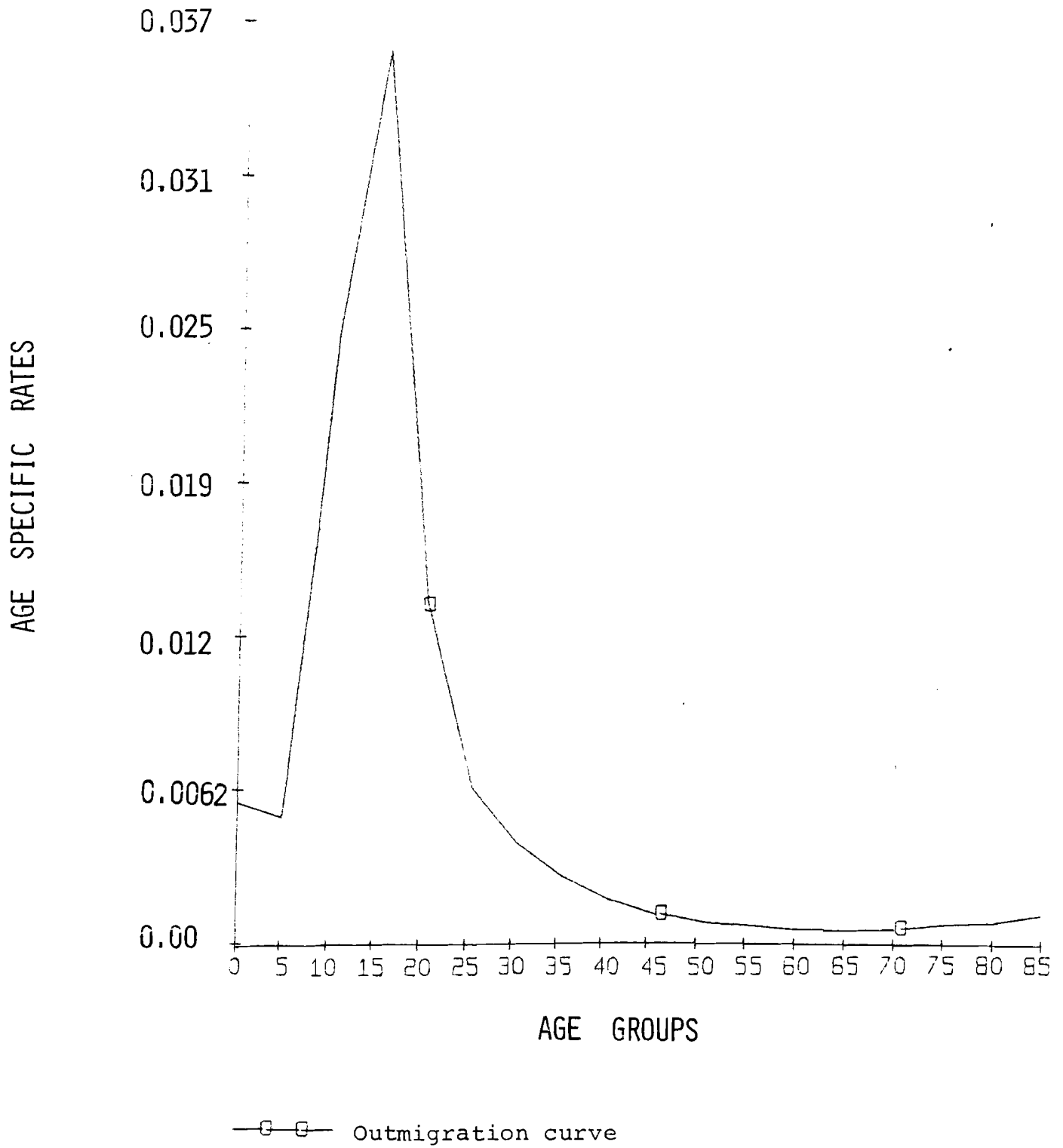

Figure 1. The outmigration schedule of the population of the Silistra region.

*Implications of the Life Table for Silistra  
and the Rest of Bulgaria*

The analysis of the observed 1975 population of Silistra will be continued by using multiregional concepts only. The life table for Silistra and the rest of Bulgaria will not be exhibited here because the two regions differ so much in size that their life-table characteristics should not be compared. Instead, implications of the life table will be discussed--they are outlined in Rogers (1975).

The expectation of life is a measure of mortality which is not influenced by the age structure of the population. The life expectancy of a Silistra baby was estimated to be 70.26 years, which is close to the one for the rest of Bulgaria--71.00 years. When infant mortality is eliminated, the difference is smaller: the life expectations of a person at the age of 5, are 67.84 and 68.04 respectively. This is the case for all other ages also. Therefore, it can be stated that the infant mortality in Silistra is higher than that of the rest of Bulgaria (this can also be observed by comparing the age-specific death rates).

The multiregional model gives the life expectancy distributed according to the regions concerned. A Silistra baby is expected to spend 48.77 years of its life in the Silistra region and 21.52 years in the rest of Bulgaria. Data on life expectancy show that the level of outmigration from the Silistra region is high, compared with the seven-region disaggregation of the country (Philipov 1978).

A well-known measure of the fertility level is the gross reproduction rate (GRR). It is the sum of the age-specific fertility rates multiplied by five. The GRR gives the number of babies per person when there is no mortality during the period of reproduction. This number is 1.21 for a person from the Silistra region and 1.11 for a person from the rest of Bulgaria. In both cases reproduction is ensured if the mortality level is reasonable.

When mortality during the reproduction period is taken into consideration, the overall measure of fertility is the net reproduction rate (NRR). In the case of the multiregional approach,

the NRR is transformed into the spatial NRR because the impact of migrations is included. The spatial NRR ( ${}_i\text{NRR}_j$ ) gives the number of babies born in region  $j$  to a person born in region  $i$ . It is computed according to the formula:

$${}_i\text{NRR}_j = \sum_{x=0}^Z {}_iL_j(x) \quad ,$$

where

${}_iL_j$  = the number of persons from the multiregional life-table population in region  $j$  and born in region  $i$ ;

$F_j$  = the age-specific fertility rates in region  $j$ ;

$Z$  = the last age group.

For the Silistra region,  ${}_1\text{NRR}_1 = 0.7845$  and  ${}_1\text{NRR}_2 = 0.3397$ , i.e., a person born in Silistra will produce 0.7845 of the births in Silistra and 0.3397 in the rest of Bulgaria to make a total of 1.1241 births. This implies that the stationary population of Silistra loses 0.3397 of its births because of the outmigrations.

Just as the GRR is computed from the age-specific rates of fertility, the gross migraproduction rates (GMR) are computed from the age-specific rates of outmigration. For the Silistra region,  $\text{GMR} = 0.53$ . This means that a person born in the region is expected to make 0.53 moves with a life of average length.

When mortality is accounted for, the net migraproduction rate is to be computed, according to the formula:

$${}_i\text{NMR}_j = \sum_{x=0}^Z {}_iL_j(x) M_j(x) \quad ,$$

where  $M_j(x)$  is the age-specific outmigration rate in region  $j$ . For Silistra, the total NMR is equal to 0.39, which is the number of moves per person from the stationary population if mortality is accounted for.

The life expectancy is a measure of duration--i.e., it states the number of years to be lived in a particular region.

But migration is also a recurrent event, like fertility. The NMR is a measure of the recurring of migration. Therefore, the life expectancy and the NMR give two different descriptions of the migrations.

In order to study the effect of the migrations, the analysis of the existing patterns is helped by the population projection, which is discussed further.

*Population Projection*

It is well-known by demographers that a population projection with fixed rates is not a forecast but, rather, a tool to analyze the characteristics of the observed population. The conventional single-region projection is carried out for a population with no migration, while the multiregional projection takes into account the migrations between the regions.

The projection discussed here is made on the basis of the fixed rates of fertility, mortality, and outmigration as they were observed in 1975. The results are presented in Table 3 for the years 1975, 2000, and 2025.

Table 3. Characteristics of the initial (1975), projected (2000, 2025) and the stable equivalent population of the Silistra region and the rest of Bulgaria.

	Population	Silistra	Rest of Bul.
	initial	33.60	35.36
Mean	2000	36.08	36.88
Age	2025	36.19	36.66
	stable equiv.	35.42	36.56
	initial	2.02	97.98
Share	2000	1.96	98.04
%	2025	1.88	98.12
	stable equiv.	1.59	98.41
	initial	1.007	1.014
Growth	2000	1.001	1.011
Ratio	2025	1.013	1.013



The multiregional population projection yields a number of characteristics presented in Table 3. The table also shows the values of the characteristics for the stable equivalent population of the Silistra region.

The stable equivalent population is defined as the population which, in the long run (in practice, after some 100 years), will reach the same numbers as the observed population. Therefore, it is a most useful tool with which to study the demographic characteristics of the observed population.

Mean Ages. Table 3 shows that the initial population of the Silistra region is younger than that of the rest of Bulgaria. It is aging quickly though and yet, in the year 2000, the difference will be insignificant. The stable equivalent population is more aged than the observed, but younger than the stable equivalent population of the rest of Bulgaria. Therefore, it may be inferred that the observed population of the Silistra region will age in the short- and middle-run (20-25 years) and to become younger afterwards.

This inference is of importance for the population policy in the region because it shows that the number of aged people should increase. This is shown also by the dependency ratio, defined as the proportion of the active population to the inactive population. In 1975, the dependency ratio was 0.54 and it will rise smoothly to 0.58 by 2025.

Regional Share. This is in fact the percentage distribution of the population. Silistra has 2.02 percent of the population; the percentage will decrease to 1.96 by the year 2000 and to 1.88 by 2025. The stable equivalent is 1.59 percent, which is considerably lower. Since fertility in the Silistra region is higher than that in the rest of Bulgaria, it can be inferred that the relative decrease of the regional share is due to net outmigration flow. Due to the outmigrations, the increase of the Silistra population is slower than that of the rest of Bulgaria.

Growth Ratio ( $\lambda$ ). This is defined as the ratio of the population of a given year to the population 5 years ago. The

growth ratio of the two regional populations is greater than the ratio of the period of projection, which shows that they are both increasing. Yet, the growth ratio for the Silistra population is smaller than for the rest of Bulgaria, which reflects its slower increase. It can also be seen that the Silistra population growth ratio is decreasing during the period of projection, which means that the rate of increase of the population is slowing down.

The growth ratio of the stable equivalent population is defined as the dominant root of the multiregional growth operator, therefore it is the same for all regions. In this case, it is 1.013, i.e., higher than that of the Silistra population during the same period of projection, and close to that of the population of the rest of Bulgaria.

The stable growth ratio is used to define the spatial intrinsic growth rate:  $r = 1/5 \ln \lambda$ . In this study,  $r = 6.46$  per thousand, which reflects the high natural increase of the Bulgarian population when migrations are taken into consideration.

Age Composition. The age compositions of the Silistra population in 1975 and its stable equivalent are presented in Figure 2. The figure reflects the larger size of the observed population: the area under its curve covers 176,428 persons while the area under the curve of the stable equivalent covers only 141,755 persons.

The curves reflect the inferences already made in the paper: it can easily be seen that the population is aging, that the number of aged people is increasing relatively, and that the observed population is decreasing when compared with the rest of the country.

#### SIMULATED POPULATION PROJECTIONS

The population projections discussed in the previous section were carried out on the basis of constant fertility, mortality, and migration rates. It was pointed out that such a projection is to be used for analyzing the observed population, and not for forecasting its changes.

# SILISTRA

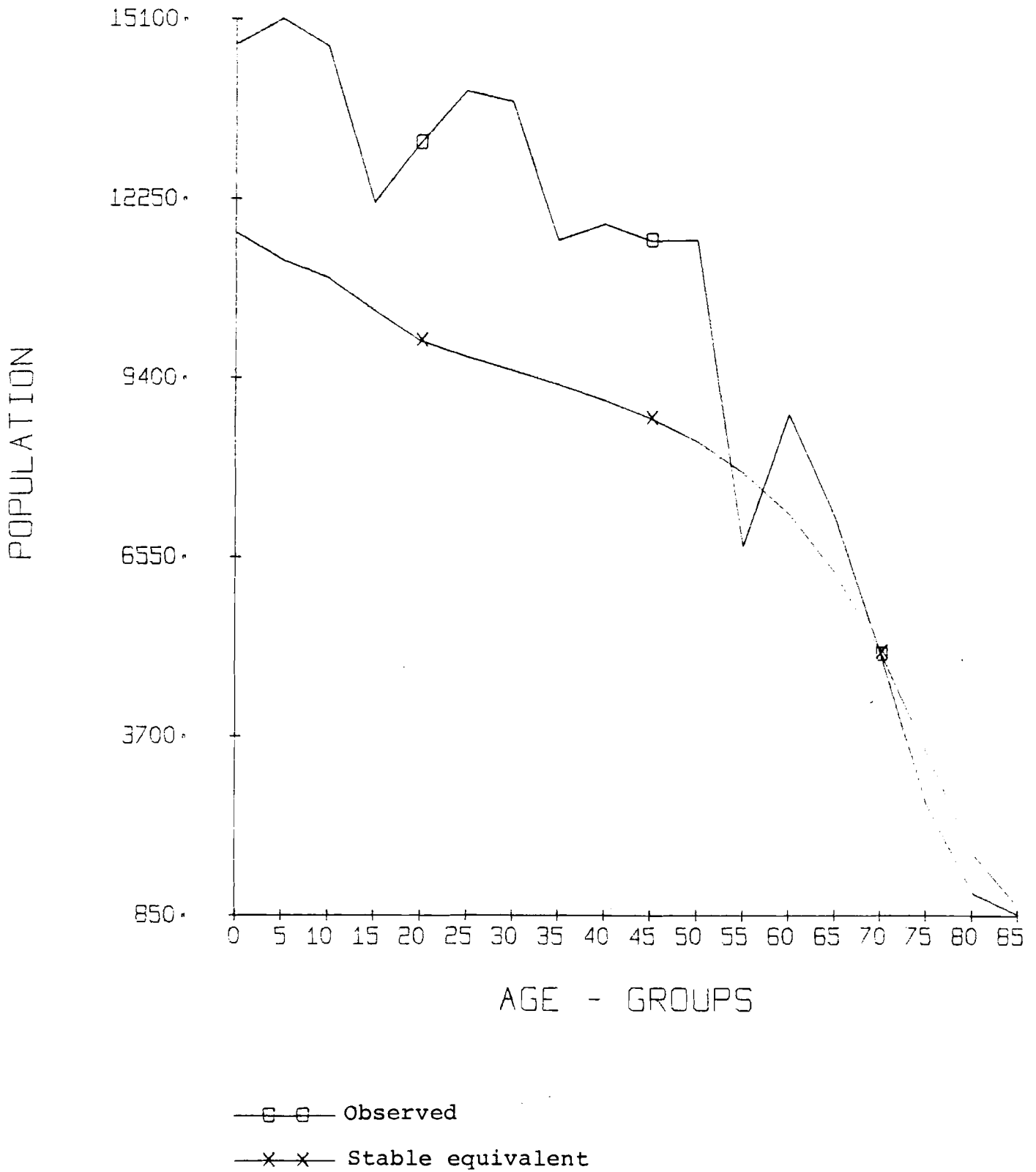

Figure 2. Age composition of the Silistra population in 1975 and its stable equivalent.

In order to forecast the dynamics of a multiregional population, it is necessary to introduce changes in the observed rates. Of course, it is impossible to change the rates exactly to the way they will be in the future. Under certain assumptions though, new values of the rates can be entered into the model and thus could influence the dynamics of the population. The new values can be obtained by two different approaches. First, from another model where the population characteristics are dependent variables and their dependence on a number of socioeconomic variables is described. No doubt such an approach is better than any other.

Second, a decision-making procedure may be adopted. It is supposed that the population characteristics will change in accordance with the population policy designed in the country and in the particular region. This approach can be used when one-time changes are introduced--for instance, how the immigration and outmigration flows will influence the behavior of the population if they are diminished or increased at a particular year.

In the case of the Silistra study, it was intended to use the first approach. A model of population dynamics has been developed by Professor La Bella. Unfortunately, the results of this model are not available yet, so the second approach was used instead.

The following changes have been suggested:

1) Fertility. The fertility analysis from the previous section showed that the fertility level in the Silistra region is above the replacement level and higher than in the rest of Bulgaria. Studies on regional birthrates in Bulgaria (Naumov et al. 1974; Stefanov et al. 1974) show that during the 20 30 years before 1970-1975, there has been a decrease in the differences among the regions. Regions with high levels exhibit a decrease and regions with low levels exhibit an increase. Therefore, it may be expected that in the future the birthrate in Silistra will diminish somewhat. At the same time, the policy to increase the birthrate adopted in the country has been effective during its 10 years of existence and there is no reason to believe that it

will not be effective in the future as well. Therefore, it can be expected that the birthrate in the whole country will rise. These two competing forces show that it is very difficult to suggest any changes in the birthrate in the Silistra region--that is why no changes have been introduced in the model.

2) Mortality. The mortality analysis showed that the largest difference exists where infant mortality is concerned (in the models, the age group 0-5 was concerned). Therefore, it was suggested that the mortality rate of this age group be decreased to the level of the rest of Bulgaria, over a period of 15 years.

The expectation of life being 71 years (after the decrease of infant mortality), it is hard to believe that there will be any major changes over a short period of time. This level of mortality has been constant in a number of countries for a very long period of time. That is why it was suggested that all the age-specific mortality rates be decreased so that the life expectancy will increase over the period of 15 years by 2.5 years in the two regions. The hypothesis is supported by the expected increase in the level of urbanization in the region, and it is well known that the mortality level is higher in the urban areas.

3) Migrations. It was shown that the outmigration flow from the Silistra region is the dominant one. It is expected that due to the investment policy and according to the planned socioeconomic development of the region, this flow will diminish. The experience in some European countries shows, however, that when investments were made, the immigration flow increased, and the outmigration flow hardly changed at all (this is the case, for instance, with Sweden) (WP-78-38).

In accordance with these observations, two hypotheses have been suggested: increasing of the immigration flow and decreasing of the outmigration flow.

The changes in the two migration flows were introduced through changes in the GMR's. The GMR defined as the sum of the age-specific migration rates multiplied by 5, is a measure of the area under the curve of outmigration (Figure 1). Hence it is an overall measure of the size of the migration flow,

which preserves the age-specific pattern of migrating. It is necessary to point out that the GMR's are estimated in accordance with the changes which take place over the population exposed to risk, during the projection process.

Changes in the GMR's reflect most accurately the effect of a migration policy. For, if only total numbers are concerned (for instance, if the outmigration flow decreases from 1400 to 700 during the period 1975-1990), the increase of the population is not accounted for, and the incentives necessary to meet the requirements might go beyond the population policy.

The two hypotheses are entered in the model by increasing the GMR of the immigration flow and by decreasing the GMR of the outmigration flow. In both cases, the changes take place over a period of 15 years (1975-1990). The changes in the magnitudes, together with combinations of the GMR's, yield a number of scenarios which are outlined below. All scenarios are designed so that any changes which could take place are in favor of the Silistra region, because the development of the region suggests an increase of its attractiveness.

The scenarios of the simulated projections have in common one change only (except for the first scenario): a decrease in the mortality rates so that the life expectancy will increase by about 2.5 years in the two regions. The mortality rate for the age-group 0-5 in Silistra is also decreased to the level in the rest of Bulgaria.

${}_1\text{GMR}_2$  further denotes the GMR for the flow from Silistra to the rest of Bulgaria.  ${}_2\text{GMR}_1$  refers to the counterflow.

Scenario 1. No changes are entered. Its results were discussed in the previous section and will be used here for comparisons.

Scenario 2. Changes in mortality only, as described above; no changes in the GMR's. This scenario reflects a population projection under the conditions of an ineffective migration policy.

- Scenario 3. Changes in mortality; a decrease by half of  ${}_1\text{GMR}_2$ . Reflects an effective migration policy in Silistra that reduces moves out of the region, with a constant inflow because of the investments which have been planned.
- Scenario 4. Changes in mortality;  ${}_1\text{GMR}_2$  one-third its rate in Scenario 2. Reflects an extreme migration policy in the region.
- Scenario 5. Changes in mortality;  ${}_2\text{GMR}_1$  doubles. Reflects the countereffect of the migration policy, that the region will become attractive for outsiders only.
- Scenario 6. Changes in mortality;  ${}_2\text{GMR}_1$  triples. Reflects an extreme countereffect of the migration policy.
- Scenario 7. Changes in mortality; a decrease by half of both  ${}_1\text{GMR}_2$  and  ${}_2\text{GMR}_1$ . Reflects an effective migration policy in the Silistra region and in the rest of Bulgaria.
- Scenario 8. Changes in mortality;  ${}_2\text{GMR}_1$  doubles and a decrease of  ${}_1\text{GMR}_2$  to half of its level in Scenario 1. This scenario reflects the impact of the planned regional development on the migration flows.
- Scenario 9. Changes in mortality;  ${}_2\text{GMR}_1$  triples and a decrease by two-thirds  ${}_1\text{GMR}_2$ . Reflects an extreme case of the assumptions of Scenario 8.

The detailed results of some scenarios are given in the Appendix. Table 4 presents the results of the projections under the nine scenarios. The data are given as follows:

1. The proportional distribution of the total numbers in three age groups: 0-14, 15-64, 65+. This allows for a brief analysis of the effect of a given simulation on the population of working age (15-64) and on the young (0-15) and old (65+) dependents.
2. M. AGE. The mean age is an overall measure of the age distribution and can be used for a preliminary comparison of different simulations.

Table 4. Results of population projections under nine scenarios.

SCENARIOS	1	2	3	4	5	6	7	8	9
	1 9 9 0								
1 9 7 5									
0-14	0.2369	0.2358	0.2377	0.2383	0.2383	0.2406	0.2364	0.2400	0.2429
15-64	0.6496	0.6464	0.6468	0.6470	0.6467	0.6469	0.6467	0.6471	0.6475
65+	0.1135	0.1178	0.1155	0.1148	0.1151	0.1125	0.1169	0.1129	0.1096
M.AGE	35.41	35.64	35.31	35.20	35.24	34.86	33.51	34.92	34.44
TOTAL	185307	186695	190631	191980	191407	196112	188247	195442	201663
	2 0 0 5								
0-14	0.2326	0.2297	0.2403	0.2439	0.2425	0.2528	0.2336	0.2519	0.2642
15-64	0.6400	0.6316	0.6322	0.6324	0.6321	0.6325	0.6320	0.6326	0.6330
65+	0.1274	0.1387	0.1274	0.1237	0.1254	0.1147	0.1344	0.1155	0.1028
M.AGE	36.23	36.83	35.53	35.10	35.29	34.05	36.34	34.14	32.65
TOTAL	189107	193218	211823	218656	215039	236766	200178	235285	266650



3. TOTAL: gives the total number of persons.
4. The results are presented for the initial year 1975, for 1990 and for 2005, i.e., two consecutive periods of 15 years are covered. The program for the development of the Silistra region is planned to take place until 1990, and that is why the data are presented for this year. Bearing in mind that demographic changes have a long-run effect on the population characteristics, it is necessary to study the projected population numbers over a longer period of time, and that is why the data for the year 2005 are presented.

The results will further be analyzed separately for the working population and for the three age groups.

Labor resources. The proportion of the age group 15-64 in 1990 is the same for the different scenarios, but is a little smaller than in 1975. Therefore, it can be expected that under any assumptions of demographic changes, the dependency ratio (non-working population to total population) will slightly increase. In 2005, the proportion of the working population is the same for all Scenario 1. The decrease in comparison with 1975 is a drop of 2 percent.

On the basis of these observations, the following inferences can be made. During the first 15-year period, there will be hardly any necessity to redistribute the social investments with regard to the proportion of the labor resources to the total population. During the second 15-year period, the distribution of the social investments must be adequate for the 2 percent increase of the dependents.

The totals of the labor resources will change considerably under the specifications of the scenarios. Bearing in mind the uniformity of their proportions, it suffices to discuss the numbers referring to the total population.

The comparison between Scenarios 1 and 2 shows that the decrease of the mortality rates brings about an insignificant increase of the total population in 1990. Until 2005 this increase is still insignificant, but must not be neglected. The totals of the other scenarios are somewhat larger, hence the changes in the

migration rates are not so important for the future population growth as the changes in the migration flows.

The scenarios 3, 4, and 5 give an increase of the labor force with approximately 3000 persons in 1990 when compared with the first scenario. The difference is considerable in 2005-- approximately 10,000-15,000 persons. Obviously, such a number of working people will be of great importance to the socio-economic life of Silistra.

The increase which is reached by Scenario 7 is not so large. It is an intermediate point between the two groups of scenarios considered above.

Scenarios 6 and 8 give an increase of the labor force, which is considerable by 1990, of approximately 7000 persons. The difference in 2005 is about 30,000 persons, which can be crucial to the later socioeconomic life in the region.

A surplus of 10,000 persons in 1990, which is reached under the specifications of Scenario 9, can be a burden or an aid to future development, as was discussed in the Introduction. The difference in 2005 is so large that the surplus can hardly be expected to help, for a surplus of 50,000 persons in the labor force is difficult to accommodate in a small region like Silistra. Recall that in 1975 the labor force is 100,000 persons.

The analysis of the nine scenarios can be briefly linked with the probable future needs of the labor force as follows. If the economic models show that only a small increase of the labor force is desired, the best results are yielded by Scenarios 1, 2, and 7, and partially by 3, 4, and 5. If the models show needs for a substantial increase, then Scenarios 6 and 8 give suitable results. Finally, Scenario 9 gives results which meet the needs of an enormous increase of the labor force. Precautions are necessary if the migration flows happen to follow the assumptions under Scenarios 6, 8, and 9, for during the second time period (1990-2005), they lead to an enormous increase of the labor force, which may well cause a number of problems.

Dependents. Here, the population proportions of the age groups 0-14 and 65+ will be analyzed.

During 1990, the proportions are placed within a very small range, the extremes being given by Scenarios 2 and 9. In general the outcome is that the population is aging, therefore a part of the investments for the population in the age group 0-14 (children, houses, schools, etc.) have to be transferred to meet the needs of the aged people (pensions, etc.). By 2005, some differences appear among the scenarios. It can be seen that the scenarios, with increasing migration flows, bring about a decrease in the mean age, i.e., a gain in the proportion of youngsters. The gain is due to the decrease in the proportion of people aged 15-64. Therefore, during the second 15-year period, the transfers of the investments must be directed from the labor force to the youngsters.

The analysis of the proportions is useful both for the distribution of the investments and for their total size. The total numbers of the two groups of dependents are the main factors for studying the amount of investments which are necessary to meet the needs of the population. Such an analysis will follow the above lines of discussion for the labor force, and need not be repeated here. It will only be pointed out that the assumptions of Scenario 9 lead to an enormous increase of the regional population, and this calls for a really substantial enlargement of the investments which are indispensable to meet the people's needs. That is why a policy encouraging such migration could be "self-destructive" rather than "catalytic".

Finally, it must be stated that scenarios giving increasing migration flows (5, 6, 8, and 9) show that difficulties of another type may arise. Namely, the enlarged number of newcomers has to be considered for the physical planning of the settlements, for housing construction, etc. Especially important is the problem of housing, because the main direction of the flow is rural-urban, and therefore the growth of the urban areas is much faster.

#### CONCLUSION

In this report, the simulated population projections were based on the assumption that the socioeconomic development of the Silistra region will lead to a decrease in the net

outmigration flow. Based on this assumption, the simulations were carried out for different changes of the immigration and outmigration flows. It was shown that the changes in the magnitude of the flows lead to changes of the population numbers which are much larger than changes in the mortality rates.

It was shown also that an extreme effect of the migration policy and of the economic planning will lead to an enormous increase in the regional population. Reasonable changes lead to results which seem to be favorable to the regional development. In any case, the results under different assumptions differ considerably, and it may therefore become necessary to optimize the magnitude of the migration streams so that they are consistent with the demands of the economic models. The increase in the total number of moves may cause some problems from the social point of view, but such a study must be enlarged to include the qualifications of the migrants which are "exchanged" by the two regions.

Note: the results in this report are based on the data in Table 1. The major problem with the data is that the age distribution of the two flows was not available to the author. The age distributions of the departures and the arrivals was used, which include the moves within the region. The total numbers of the interregional flows were disaggregated according to the percentage distribution of the departures and the arrivals. Such a procedure could be wrong, because the migration schedules of the interregional and intraregional moves could differ substantially. If this happens to be the case, the results of the simulations will differ considerably from those discussed here.

Appendix I gives the results of Scenario 7, which in general opinion is expected to be the most probable one.

REFERENCES

- Andersson, A.E., and I. Holmberg (1978) Migration and Settlement Patterns in Sweden: Description, Explanation, and Policy. WP-78-38. Laxenburg, Austria: International Institute for Applied Systems Analysis.
- Naumov, N., et al. (1974) La Population de la Bulgarie, C.I.C.R.E.D. Series. Sofia.
- Philipov, D. (1978) Migration and Settlement in Bulgaria. RM-78-36. Laxenburg, Austria: International Institute for Applied Systems Analysis.
- Rogers, A. (1975) Spatial Migration Expectancies. RM-75-57. Laxenburg, Austria: International Institute for Applied Systems Analysis.
- Rogers, A. (1976) Introduction to Multiregional Demography. Chichester: John Wiley and Sons.
- Stefanov, I. et al. (1974) Demography of Bulgaria. Manka i Izkustvo. Sofia (in Bulgarian).
- United Nations (1974) Methods for Projections of Urban and Rural Population. New York.
- Willekens, F., and A. Rogers (1976) Computer Programs for Spatial Demographic Analysis. RM-76-58. Laxenburg, Austria: International Institute for Applied Systems Analysis.

APPENDIX

The multiregional population projection: year 1975.

POPULATION			
- - - -			
AGE	TOTAL	SILISTRA	R. OF BUL.
0	667557.	14686.	652871.
5	637942.	15096.	622846.
10	627062.	14657.	612405.
15	638493.	12182.	620311.
20	655339.	13126.	642213.
25	690259.	13950.	676309.
30	577640.	13784.	563856.
35	563393.	11579.	551814.
40	634750.	11842.	622908.
45	632732.	11577.	621155.
50	615127.	11590.	603537.
55	371267.	6707.	364560.
60	449665.	8815.	440850.
65	391262.	7166.	384096.
70	282709.	4998.	277711.
75	168881.	2621.	166260.
80	74977.	1193.	73784.
85	48710.	859.	47851.
TOTAL	8727765.	176428.	8551337.
BIRTHS	144629.	3192.	141437.
DEATHS	89974.	1719.	88255.
EMIG	0.	0.	0.
IMMIG	0.	0.	0.

MIGRATION FLOWS (FROM COLUMN TO ROW)

ARRIVALS SILISTRA R.OF.BUL

SILISTRA	2572.	1731.	841.
R.OF.BUL	1374.	1374.	0.
DEPARTURES	3946.	3105.	841.

SUMMARY TABLE

REGION	POPULATION ,000.	% M.	AGE	RATES OF BIRTH	NATURAL DEATH	INCREASE GROWTH	GROWTH RATE
SILISTRA	176.	2.02	33.60	0.018092	0.009743	0.008349	0.005328
R.OF.BUL	8551.	97.98	35.36	0.016540	0.010321	0.006219	0.006281
TOTAL	8728.	100.00	35.33	0.016571	0.010309	0.006262	0.006262

DEMOGRAPHIC PARAMETERS

\*\*\*\*\*

SILISTRA R.OF.BUL

GRR	1.210282	1.108520
GDR	3.106431	2.894158
GMR		
SILISTRA	0.669588	0.006949
R.OF.BUL	0.533649	0.000000
GMR TOT	1.203237	0.006949

LIFE EXPECTANCIES

\*\*\*\*\*

SILISTRA R.OF.BUL

SILISTRA	48.73813	0.28198
R.OF.BUL	21.52022	70.71629
TOTAL	70.25835	70.99828

YEAR 1980

POPULATION

AGE	TOTAL	SILISTRA	R.OF.BUL
0	706809.	15200.	691608.
5	656873.	14250.	642622.
10	636447.	14650.	621797.
15	625264.	13721.	611543.
20	635845.	11616.	624228.
25	652100.	12846.	639254.
30	686275.	13744.	672530.
35	573179.	13578.	559601.
40	557192.	11394.	545798.
45	623929.	11597.	612333.
50	615794.	11227.	604567.
55	590161.	11046.	579115.
60	346839.	6226.	340612.
65	400461.	7765.	392696.
70	321139.	5812.	315327.
75	202598.	3474.	199124.
80	97663.	1402.	96260.
85	44680.	651.	44029.
TOTAL	8973247.	180201.	8793046.
LAM	1.028127	1.021386	1.028266
R	0.005548	0.004232	0.005575
BIRTHS	142270.	3029.	139241.
DEATHS	97992.	1857.	96135.
EMIG	0.	0.	0.
INNIG	0.	0.	0.

MIGRATION FLOWS (FROM COLUMN TO ROW)

	ARRIVALS	SILISTRA	R.OF.BUL
SILISTRA	2617.	1774.	843.
R.OF.BUL	1408.	1408.	0.
DEPARTURES	4024.	3162.	843.



SUMMARY TABLE

REGION	POPULATION			RATES OF NATURAL INCREASE			GROWTH RATE
	,000.	% M.	AGE	BIRTH	DEATH	GROWTH	
SILISTRA	180.	2.01	34.27	0.016807	0.010306	0.006501	0.003366
R.OF.BUL	8793.	97.99	35.79	0.015835	0.010933	0.004902	0.004967
TOTAL	8973.	100.00	35.76	0.015855	0.010921	0.004934	0.004934

DEMOGRAPHIC PARAMETERS

\*\*\*\*\*

	SILISTRA	R.OF.BUL
GRR	1.210262	1.108520
GDR	2.937041	2.729439
GMR		
SILISTRA	0.669588	0.005799
R.OF.BUL	0.444566	0.000000
GMR TOT	1.114154	0.005799

LIFE EXPECTANCIES

\*\*\*\*\*

	SILISTRA	R.OF.BUL
SILISTRA	52.14334	0.24727
R.OF.BUL	18.84780	71.49084
TOTAL	70.99115	71.73811

YEAR 1945

-----

POPULATION

-----

AGE	TOTAL	SILISTRA	R.OF.BUL
0	696444.	14981.	681462.
5	696144.	14801.	681343.
10	655419.	13941.	641477.
15	634725.	13874.	620852.
20	622819.	13066.	609753.
25	632881.	11434.	621448.
30	648550.	12684.	635865.
35	681273.	13582.	667691.
40	567228.	13373.	553854.
45	548230.	11175.	537055.
50	608162.	11264.	596894.
55	592191.	10731.	581460.
60	553449.	10297.	543153.
65	310909.	5524.	305385.
70	332327.	6370.	325957.
75	234433.	4118.	230315.
80	120787.	1922.	118865.
85	63651.	839.	62811.
TOTAL	9199622.	183981.	9015641.
LAM	1.025228	1.020977	1.025315
R	0.004983	0.004152	0.005000
BIRTHS	140186.	3090.	137096.
DEATHS	103205.	1958.	101247.
EMIG	0.	0.	0.
IMMIG	0.	0.	0.

MIGRATION FLOWS (FROM COLUMN TO ROW)

-----

ARRIVALS SILISTRA R.OF.BUL

SILISTRA	2490.	1776.	713.
R.OF.BUL	1174.	1174.	0.
DEPARTURES	3664.	2950.	713.

SUMMARY TABLE

REGION	POPULATION			RATES OF NATURAL INCREASE			GROWTH RATE
	,000.	% N.	AGE	BIRTH	DEATH	GROWTH	
SILISTRA	184.	2.00	34.96	0.016796	0.010644	0.006152	0.003647
R.OF.BUL	9016.	98.00	36.31	0.015206	0.011230	0.003976	0.004027
TOTAL	9200.	100.00	36.28	0.015238	0.011218	0.004020	0.004020

DEMOGRAPHIC PARAMETERS

\*\*\*\*\*

	SILISTRA	R.OF.BUL
GRR	1.210282	1.108520
GDR	2.767651	2.564719
GMR		
SILISTRA	0.669568	0.004650
R.OF.BUL	0.355483	0.000000
GMR TOT	1.025071	0.004650

LIFE EXPECTANCIES

\*\*\*\*\*

	SILISTRA	R.OF.BUL
SILISTRA	55.89372	0.20859
R.OF.BUL	15.86674	72.31624
TOTAL	71.76047	72.52483

YEAR 1990

POPULATION

AGE	TOTAL	SILISTRA	R.OF.BUL
0	693077.	15324.	677753.
5	686572.	14632.	671940.
10	694695.	14550.	680145.
15	653752.	13403.	640349.
20	632393.	13338.	619055.
25	620090.	12851.	607239.
30	629643.	11322.	618322.
35	644107.	12554.	631553.
40	674623.	13407.	661216.
45	558651.	13136.	545515.
50	535199.	10880.	524319.
55	586225.	10801.	575424.
60	557492.	10045.	547447.
65	499357.	9198.	490159.
70	260879.	4584.	256295.
75	247132.	4602.	242530.
80	144103.	2357.	141746.
85	86306.	1262.	85044.
TOTAL	9404295.	188247.	9216048.
LAM	1.022248	1.023189	1.022229
R	0.004401	0.004585	0.004397
BIRTHS	140670.	3157.	137513.
DEATHS	106722.	2059.	104664.
EMIG	0.	0.	0.
IMMIG	0.	0.	0.

MIGRATION FLOWS (FROM COLUMN TO ROW)

ARRIVALS SILISTRA R.OF.BUL

SILISTRA	2373.	1786.	587.
R.OF.BUL	944.	944.	0.
DEPARTURES	3317.	2730.	587.

SUMMARY TABLE

REGION	POPULATION /000.	% M.	AGE	RATES OF BIRTH	NATURAL DEATH	INCREASE GROWTH	GROWTH RATE
SILISTRA	188.	2.00	35.51	0.016771	0.010936	0.005835	0.003937
R.OF.BUL	9216.	98.00	36.82	0.014921	0.011357	0.003564	0.003603
TOTAL	9404.	100.00	36.79	0.014958	0.011348	0.003610	0.003610

DEMOGRAPHIC PARAMETERS

\*\*\*\*\*

	SILISTRA	R.OF.BUL
GRR	1.210282	1.108520
GDR	2.598260	2.400000
GMR		
SILISTRA	0.669588	0.003500
R.OF.BUL	0.266400	0.000000
GMR TOT	0.935988	0.003500

LIFE EXPECTANCIES

\*\*\*\*\*

	SILISTRA	R.OF.BUL
SILISTRA	60.03373	0.16544
R.OF.BUL	12.53773	73.20100
TOTAL	72.57146	73.36644

YEAR 1995

-----

POPULATION

-----

AGE	TOTAL	SILISTRA	R.OF.BUL
0	703426.	15610.	687816.
5	683886.	15410.	668476.
10	685235.	14442.	670792.
15	693042.	14132.	678910.
20	651504.	13038.	638466.
25	629800.	13161.	616639.
30	617121.	12729.	604392.
35	625606.	11227.	614379.
40	638220.	12412.	625808.
45	665069.	13195.	651873.
50	546212.	12815.	533397.
55	517103.	10458.	506645.
60	554002.	11153.	543849.
65	506301.	9036.	497264.
70	423660.	7721.	415939.
75	197646.	3377.	194270.
80	156617.	2724.	153893.
85	113267.	1703.	111564.
TOTAL	9607716.	192942.	9414774.
LAN	1.021631	1.024938	1.021563
R	0.004280	0.004926	0.004267
BIRTHS	144142.	3194.	140948.
DEATHS	109517.	2100.	107416.
EMIG	0.	4.	0.
IMMIG	0.	0.	0.

MIGRATION FLOWS (FROM COLUMN TO ROW)

ARRIVALS SILISTRA R.OF.BUL

SILISTRA	2272.	1821.	451.
R.OF.BUL	722.	722.	0.
DEPARTURES	2993.	2543.	451.

SUMMARY TABLE

REGION	POPULATION /000.	% M.	AGE	RATES OF NATURAL BIRTH	DEATH	INCREASE GROWTH	GROWTH RATE
SILISTRA	193.	2.01	35.96	0.016552	0.010886	0.005666	0.004262
R.OF.BUL	9415.	97.99	37.27	0.014971	0.011409	0.003562	0.003590
TOTAL	9608.	100.00	37.25	0.015003	0.011399	0.003604	0.003604

DEMOGRAPHIC PARAMETERS

\*\*\*\*\*

SILISTRA R.OF.BUL

GRR	1.210282	1.108520
GDR	2.598260	2.400000
GMR		
SILISTRA	0.669588	0.003500
R.OF.BUL	0.266400	0.000000
GMR TOT	0.935988	0.003500
GER	0.000000	0.000000

LIFE EXPECTANCIES

\*\*\*\*\*

SILISTRA R.OF.BUL

SILISTRA	60.03373	0.16544
R.OF.BUL	12.53773	73.20100
TOTAL	72.57146	73.36644

YEAR 2005

POPULATION

AGE	TOTAL	SILISTRA	R.OF.BUL
0	739171.	16136.	723034.
5	714018.	15543.	698475.
10	692746.	15078.	677667.
15	680930.	14355.	666575.
20	681253.	13640.	667613.
25	687827.	13579.	674248.
30	645726.	12758.	632969.
35	622765.	12915.	609851.
40	607561.	12468.	595093.
45	611108.	10928.	600179.
50	615173.	11919.	603254.
55	628276.	12375.	615901.
60	498717.	11575.	487143.
65	443794.	8842.	434953.
70	426863.	7667.	419196.
75	325437.	5588.	319849.
80	203421.	3367.	200055.
85	98466.	1445.	97022.
TOTAL	9923253.	200178.	9723075.
LAM	1.014537	1.016307	1.014501
R	0.002886	0.003235	0.002879
BIRTHS	150441.	3304.	147138.
DEATHS	120683.	2350.	118333.
EMIG	0.	0.	0.
IMMIG	0.	0.	0.

MIGRATION FLOWS (FROM COLUMN TO ROW)

ARRIVALS SILISTRA R.OF.BUL

SILISTRA	2337.	1879.	458.
R.OF.BUL	744.	744.	0.
DEPARTURES	3082.	2624.	458.

SUMMARY TABLE

REGION	POPULATION ,000.	% M.	AGE	RATES OF NATURAL BIRTH	DEATH	INCREASE GROWTH	GROWTH RATE
SILISTRA	200.	2.02	36.34	0.016503	0.011740	0.004763	0.003334
R.OF.BUL	9723.	97.98	37.54	0.015133	0.012170	0.002963	0.002992
TOTAL	9923.	100.00	37.52	0.015160	0.012162	0.002999	0.002999

DEMOGRAPHIC PARAMETERS

\*\*\*\*\*

	SILISTRA	R.OF.BUL
GRR	1.210282	1.108520
GDR	2.598260	2.400000
GMR		
SILISTRA	0.669588	0.003500
R.OF.BUL	0.266400	0.000000
GMR TOT	0.935988	0.003500
GER	0.000000	0.000000

LIFE EXPECTANCIES

\*\*\*\*\*

	SILISTRA	R.OF.BUL
SILISTRA	60.03373	0.16544
R.OF.BUL	12.53773	73.20100
TOTAL	72.57146	73.36644





MIGRATIONS IN THE SYSTEM OF MODELS  
FOR INTEGRATED TERRITORIAL DEVELOPMENT

Boris Mihailov

INTRODUCTION

The problem of modeling of the migrations is a complex one and comprises many different aspects due to their links with:

- demographic processes (fertility and mortality);
- economics;
- social conditions;
- political constraints;
- psychological motivations;
- spatiality.

It can, however, be said that *the investigations in the sphere of modeling of the migrations to date have been mainly directed to the influences of different factors on the migrations and have inadequately taken into account the repercussions (feedback) of the migrations on the development of different spheres and activities. In this sense the problem of regulating the migration processes is less elaborated in the regional aspect.*

The elaboration of the system of models for integrated territorial development of the Silistra region enables us to improve both the modeling of integrated regional development and of the migrations.

Migration flows are connected mainly with the movement of labor resources. In Bulgaria, great importance is paid to the problem of labor resources, their movement and their effective utilization. In this respect, many government decisions are adopted, as for example:

- elaboration of a general scheme for territorial distribution of productive forces and national balance of labor resources;
- extension of the private households to reach self-sufficiency of the population in terms of agricultural products, with the aim to fully utilize the labor of the total population;
- construction of a system of services which is based on the territorial allocation of the population as consumers of the services;
- implementation of two and three work shifts per day in the material sector with the aim of fully utilizing capital.

It can be claimed that where problems connected with labor resources, their movement and utilization are concerned, *one feels the lack of the models for regional decision-making. The Silistra project is an appropriate case for solving these problems.* It is necessary to stress that the economic mechanism for management in Bulgaria is centralized, which will influence to some extent the assigning of input of some parameters to the model of the migrations. At the same time, the subjective character of the motivation of the personal behavior will move closer the instruments for the regulation of migration processes in centrally planned economies to those in market economies. One can also claim that differences in mechanisms of management in different countries will provoke differences rather in the approach to the calculation scheme

connected with the modeling of the migrations than in the instruments for their practical regulation, which makes the mutual participation of specialists from different countries working on this complex problem especially useful.

*This report will further be based on the following initial conditions:*

- an intraregional input-output model should be elaborated within the region in order to provide constraints to the different subsystem models, including the model of the migrations;
- separate models with local criteria for different productive and non-productive subsystems should be elaborated, in which the problem of labor resources will play an important role;
- despite local optimums for development of the separate subsystems, strategic-type models have to be solved within the framework of the region in order to satisfy the global optimum of the region;
- the reverse influence of migrations on the separate subsystem's development requires that the migration processes be regulated in terms of the appropriate instruments.

The defining of the parameters in the migration model, the linkage with the other subsystem models, and the instruments for its solution, require that *systems analysis has to be carried out within the following main problems and in the following sequence.*

1. The scope of the migration model has to be defined and differentiated from the other subsystem model of the region.
2. The factors which influence the size of the migration flows have to be investigated and be linked with the parameters of the remaining subsystem models within the region.
3. The calculation scheme of the migration modeling and its regulation has to be connected with the optimization scheme of the whole system of regional models.

The main goal of this investigation is to define such an approach to the modeling of the migrations as a subsystem which will serve as improvement to the optimization scheme of the whole system of regional models.

#### SCOPE AND DIFFERENTIATION OF THE MIGRATION MODEL (MM)

The investigation of the problems connected with the migrations enables us to clarify the subject of MM: namely, it is a spatial demographic process, i.e., population movement under the influence of demographic, economic, and social factors, the consequences of that movement, and its regulation. Determining the subject of migration modeling in this way requires that special attention be paid to spatiality in the other subsystem models within the framework of the region.

It is obvious that the migration flows, in spite of the factors which have provoked them, are constrained by the demographic changes in the population. The population demographic growth in the single-region case may be expressed by the well-known Leslie model (see Keyfitz 1968) [2]:

$$\{K_{\sim p}^{t+n}\} = L_{\sim p} \{K_p^t\} , \quad (1)$$

where

$\{K_{\sim p}^{t+n}\}$  = column-vector of the projected population of subregion p (or a point within the region) after n time-periods of projection;

$L_{\sim p}$  = Leslie matrix derived by the fertility and mortality rates in the same subregion;\*

$\{K_p^t\}$  = column-vector of the population under analysis during the initial year t in subregion p.

---

\*For ease of exposition,  $L_{\sim p}$  is one and the same for all p.

This model has to be used at the initial stage of the regional input-output model.

The Rogers' model [7] can be used successfully to forecast the population growth, and to define the size of the inter-regional migration flows:

$$\{K_{\sim p}^{t+n}\} = G_{\sim p} \{K_p^t\} , \quad (2)$$

where

$\{K^{t+n}\}$  = column-vector of the projected population of all the subregions;

$G$  = multiregional growth matrix (Rogers 1975);

The multiregional model was applied to the biregional system Silistra-rest of Bulgaria. The projection is expressed graphically in Figure 1 using formula (2). As compared with the population growth projection without migration in Figure 2 (the computations were made by D. Philipov using formula (1)) one can observe the effect of a negative migration flow to the Silistra region.

It is necessary to point out that this approach to derive migration flows does not answer the following question: Which are the factors and how do they influence the size of the migration flows? It is obvious that the influencing factors during the initial year will change during the projection period. *Hence, if we directly connect the migration rates with the factors from which the migrations depend, the above-shown approach can be used successfully for forecasting the size and structure of the migration flows for a prospective period.*

In this way the MM can be differentiated as independent with its own significance in the system of regional models.

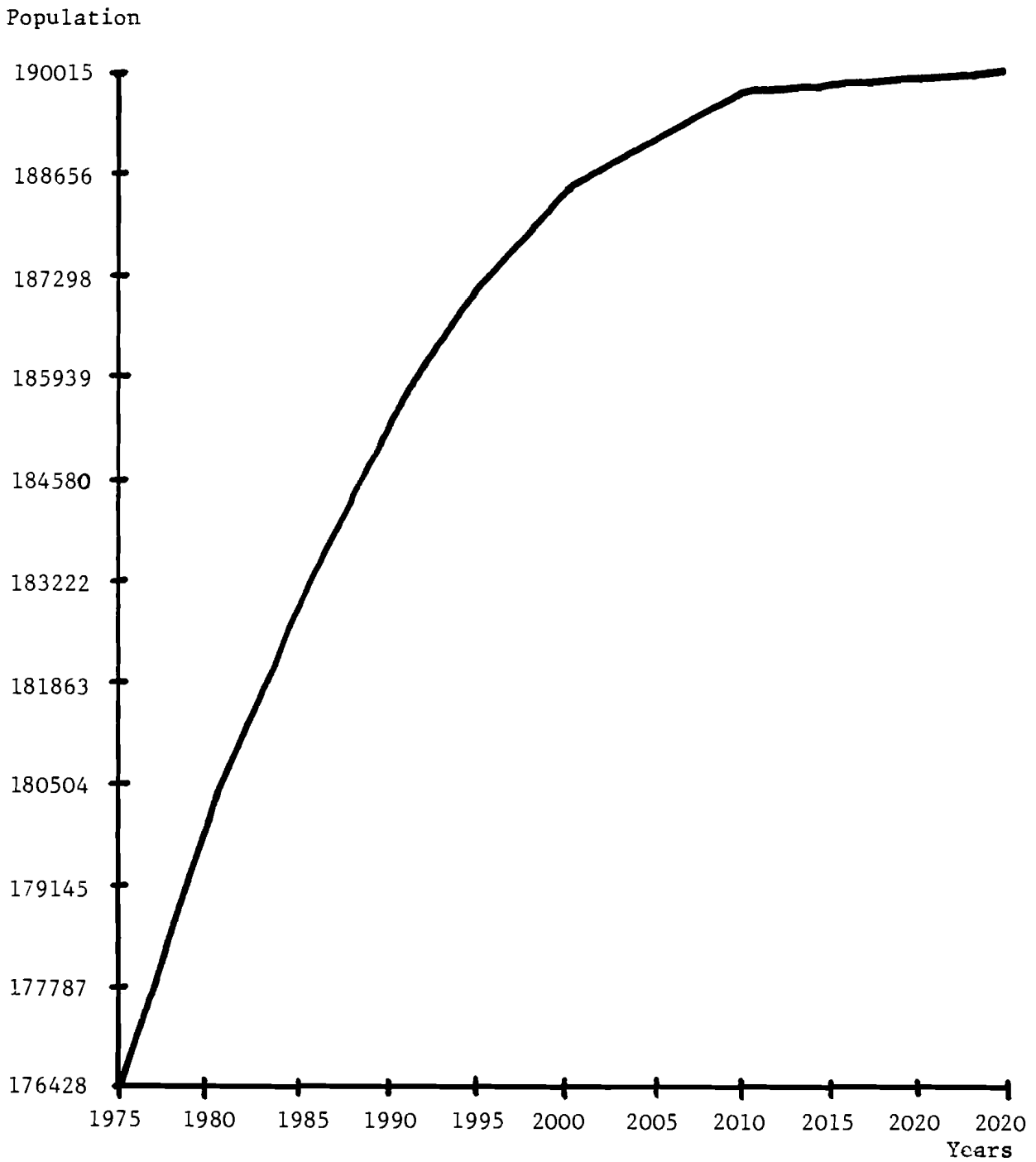

Figure 1. Bi-regional projection of the Silistra population (Silistra--rest of Bulgaria).

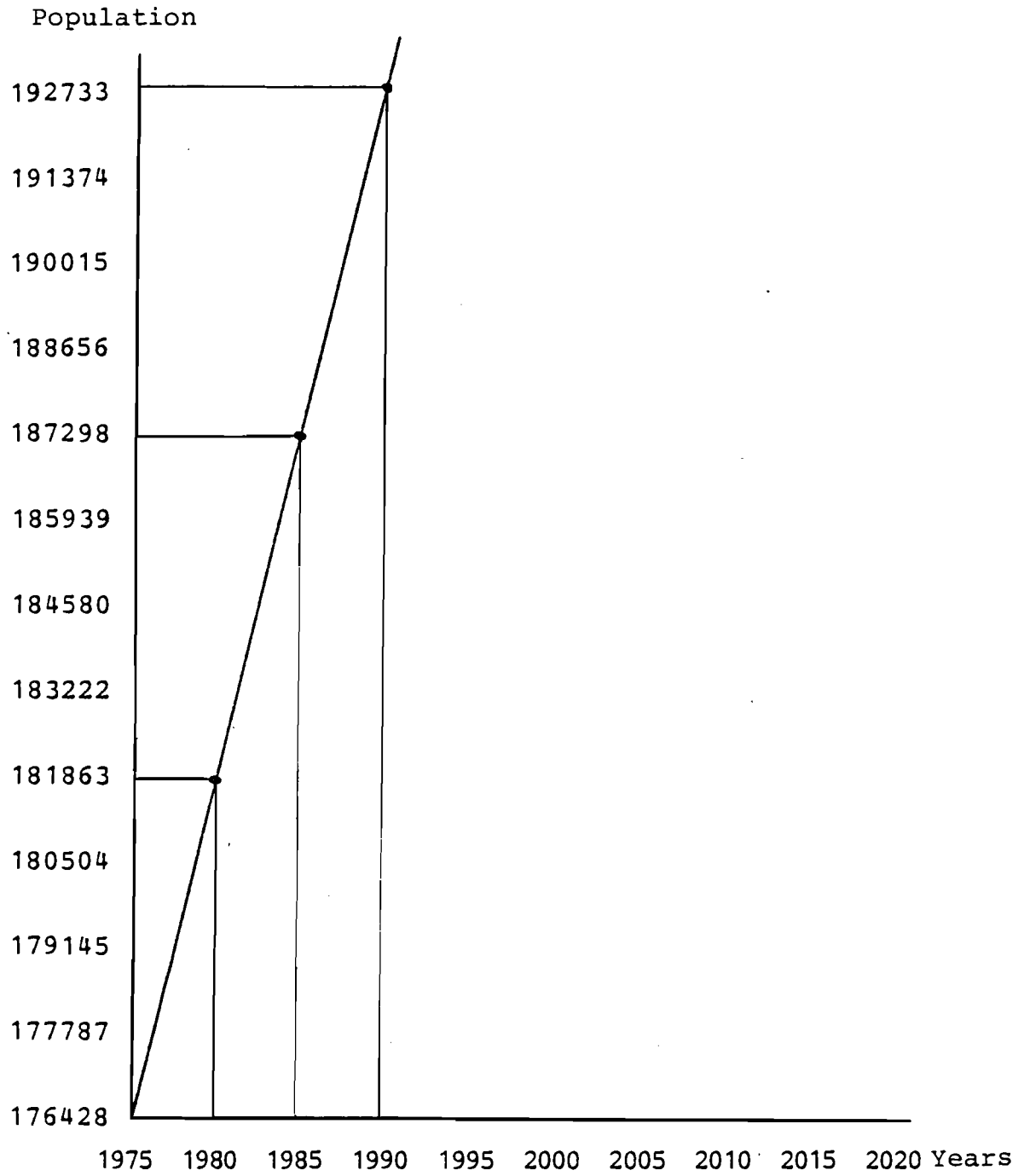

Figure 2. Single region projection of the Silistra population.



FACTORS INFLUENCING THE SIZE OF THE MIGRATION FLOWS

The age-structure of the population is of extreme importance in the investigation of factors which influence the migrations. This enables one to investigate the place and role of labor resources in the integrated system of regional models.

In accordance with the remarks above, one can persuade the following main ideas:

- more precise definition of the MM and the other subsystem models (in the latter, labor resources take part in defining the efficiency of their activity);
- a comprehensive analysis of factors which influence the movement of the labor resources; and
- linkage of the MM with the other subsystem models.

A general idea concerning the relations between the labor resources and the other subsystem models in the region is presented in Figure 3.

Generally, we can see from the scheme that the model of labor resources and other subsystem models are interrelated: the first model supplies the others with data on a labor force, while the other models provide data on commodities, facilities, lifestyle, etc., concerning the population and labor resources.

The formation of labor resources by subregions and their movement can be expressed with the following equation:

$$L_p^{t+n} = K_p^{t+n} - N_p^{t+n} + \sum_{\substack{p=1 \\ i \neq p}}^r M_{ip}^{t+n} + \sum_{\substack{p=1 \\ i \neq p}}^r CP_{ip}^{t+n} , \quad (3)$$

where

$L_p^{t+n}$  = the labor resources in subregion p after n time-period;

$K_p$  = demogrowth of population in subregion p (defined by formula (1));

$N_p$  = inactive population in subregion p (defined by formula (1));

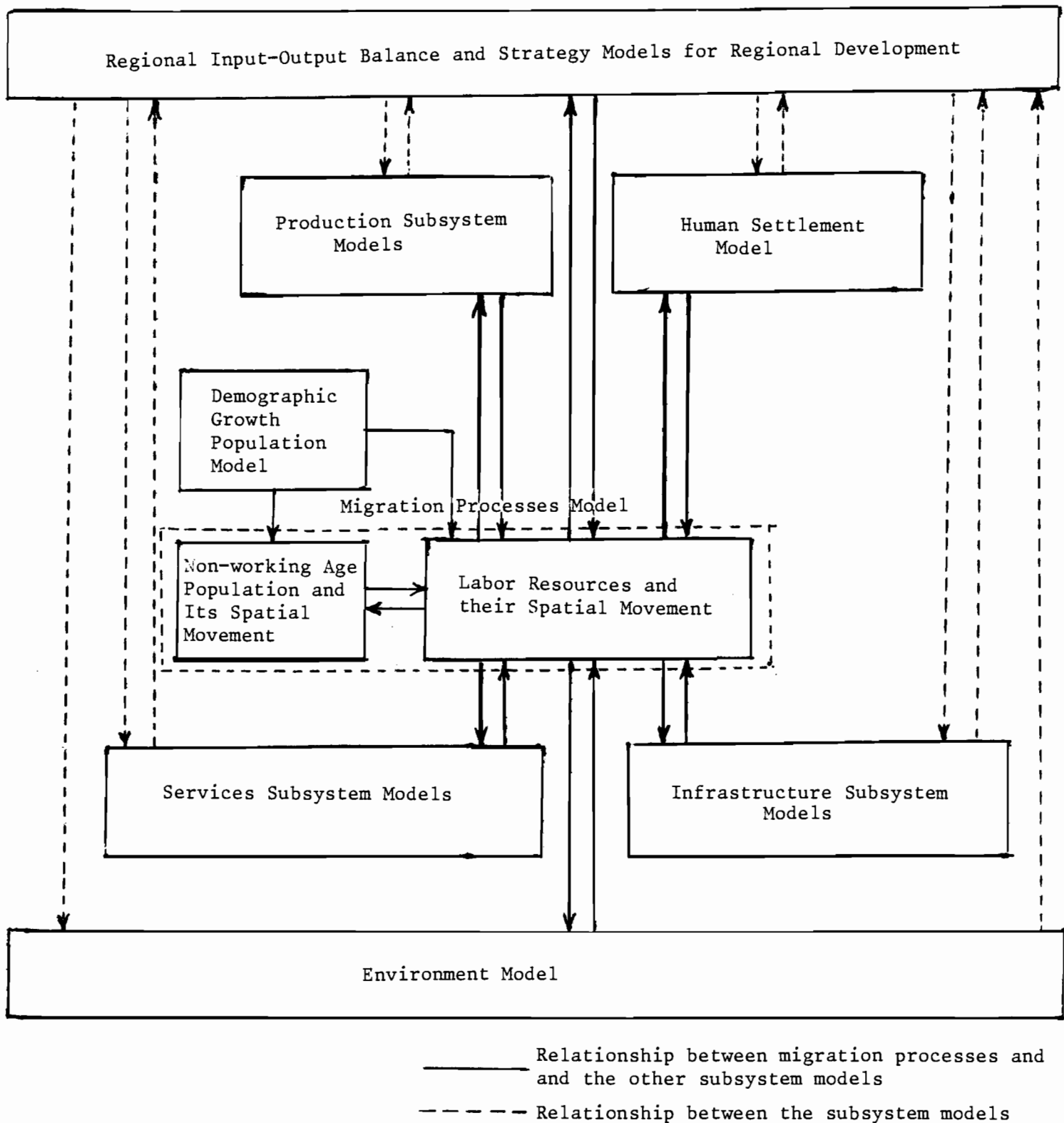

Figure 3. Relationship between the migration model and the other subsystem models.

- $r$  = the total number of subregions;  
 $M_{ip}$  = the net migration flow between subregions  $i$  and  $p$   
 (defined by formula (2));  
 $CP_{ip}$  = the net number of commuters between subregions  
 $i$  and  $p$ .

Since the basic regional input-output model will play an important role in the equilibrium of the subsystem elements within the region (including labor resources) it is necessary to include there the separate subsystems as a basis for the allocation of the labor resources:

$$\sum_{p=1}^r \sum_{i \in J} (X_{ip}^t + Im_p^t) = \sum_{p=1}^r \sum_{j \in J} (A_{ij} X_{jp}^t + B_{ij} X_{jp}^t + Ex_p^t) + \sum_{p=1}^r (\alpha_i Z_1^t + \beta_i Z_2^t) \quad (4)$$

$$i \in I, \quad j \in J, \quad p \in P,$$

where

- $X_{ip}^t$  = volume of the  $i$ -th product produced in the  $p$ -th subregion during the initial year  $t$ ;  
 $r$  = the number of the subregions;  
 $Im_p$  = import to the subregion  $p$  from other regions;  
 $Ex_p$  = export from subregion  $p$  to other regions;  
 $A_{ij}$  = volume of  $i$ -th product needed for the production of unit of  $j$ -th product (for current productive consumption of the separate subsystems);  
 $B_{ij}$  = production fund coefficient;  
 $\alpha_i Z_1$  = volume of  $i$ -th product for final non-productive consumption by the population ( $\alpha_i$  = assortment coefficients for participation of the  $i$ -th product in the total volume of the production for consumption);

$\beta_i Z_2$  = volume of the  $i$ -th product for consumption by the non-productive subsystems ( $\beta_i$  coefficients analogous to  $\alpha_i$ ).

The differentiation of the subsystems in the regional balance makes it possible to differentiate the allocation of the labor resources when the latter are viewed as productive resources. This may be expressed in the following way:

$$\sum_{p=1}^r \sum_{j \in J} \left( L_{mp}^t + L_{mp}^{im.,t} = \sum_{p=1}^r \left( v_{m1} X_{jp}^t + v_{m2} X_{jp}^t + v_{m3} X_{jp}^t + v_{m4} X_{jp}^t + \sum_{i \in I} L_{mp}^{ex.,t} \right) \right) \quad (5)$$

where

$L_{mp}^t$  = quantity of local resources in subregion  $p$  by  $m$ -th type of qualifications ( $m = 1, 2, \dots, n$ ) during basic year  $t$ ;

$L_{mp}^{im.,t}$   $L_{mp}^{ex.,t}$  = labor resources from and to other regions;

$v_1, v_2$  } labor coefficients for participation of the  
 $v_3, v_4$  } labor force relatively in the subsystems, producing products for current consumption, for productive funds, for final consumption and for non-productive subsystems.

Summarizing the labor resources by columns of the input-output table makes it possible to derive the total quantity of labor resources used by different types of qualifications in the different subsystems and by the subregions of the region:

$$L_{mp} = \sum_{i=1}^r \sum_{i \in I} v_{mj} X_{jp} \quad (6)$$

The gross wages by subsystems and subregions of the region may be expressed as follows:

$$V_{jP} = \sum_{i=1}^r \sum_{i \in I} v_{mj} \gamma_{mi} X_{jp} \quad , \quad (7)$$

where

$\gamma_{mi}$  = normative wage by m-th type of qualification in the i-th sector.

The balancing of labor resources within the region by subregions enables us to derive the differentiation of the socio-economic conditions by subregions, both with regard to labor resources utilization and to meeting the needs of the labor resources and the population with different products, services and facilities. The differentiation of conditions concerning labor resources, can be done by subregions within the region and outside the region, as follows:

- the differentiation of labor resources by qualification types:  
( $m = 1, \dots, n, \dots, n+q$ ) where:  $n+q$  - index for the differentiation outside of the region, in  $q$  previously specified number of places;
- differentiation of labor resources by the obtained wage volume  $V_j$  ( $j = 1, \dots, m, \dots, m+n$ ) where:  $m+n$  = differentiation outside of the region, in  $n$  previously defined number of places;
- differentiation of labor resources utilization in different activities:

$$v_{mj} = \frac{L_j}{X_{ij}} \quad , \quad (j = 1, \dots, n, \dots, n+q) \quad ,$$

where:  $q$  = previously defined number of places out of the region;

- differentiation of the population by meeting the needs with products for current personal consumption:

$$\frac{\alpha_i Z_1}{K_p} ; \quad \frac{\alpha_i Z_1'}{K_q} ,$$

(the second fraction here and further refers to the differentiation outside of the region);

- differentiation of the population by meeting the needs of dwelling area:

$$\frac{\beta_i Z_2}{K_p} ; \quad \frac{\beta_i Z_2'}{K_q} ,$$

- differentiation of the population by potentiality for education:

$$\frac{\beta_i Z_3}{K_p} ; \quad \frac{\beta_i Z_3'}{K_q} ,$$

- differentiation of the population by availability of health care services:

$$\frac{\beta_i Z_4}{K_p} ; \quad \frac{\beta_i Z_4'}{K_q} ,$$

- differentiation of the population by availability of cultural facilities:

$$\frac{\beta_i Z_6}{K_p} ; \quad \frac{\beta_i Z_6'}{K_q} .$$

The above differentiations in living and working conditions of the population and of the labor resources in different subregions of the region express the factors which form the population's motivation to migrate from one subregion to another, or

out of the region. This means that the differentiation by a variety of factors requires to differentiate the relative subregions of potential inflow or outflow of the population within the region and out of the region. This shows, on the other hand, the objective fact that *as a rule, the labor resources distribution by means of the regional input-output model (respectively by means of subsystem models) will always differ from the real distribution of labor resources expressing the propensity of the population to migrate to different subregions of the region or out of the region.*

In this respect the following inequality will be valid:

$$\sum_{p=1}^r K_p^{t+n} + \sum_{p=1}^r \sum_{j \in J} L_p^{t+n} - \sum_{p=1}^r N_p^{t+n} \geq \sum_{p=1}^r \sum_{j \in J} M_{ip}^{t+n}, \quad (8)$$

(the elements are taken from formula (3) without considering the commuting patterns and  $L_p^{t+n}$  is derived from formula (5) through regional input-output model). The above difference is due to the fact that the deriving of the size of the labor resources by means of regional input-output model and other subsystem models has not taken into account the factors which provoke migration of the population. The above circumstances raise two basic problems to be solved by the system of regional models: the first requires that the real size of the migration flows be defined taking into account the factors which provoke them; the second requires that the migrations be regulated in the direction which would satisfy both the criteria used by planners and the personal incentive of the population.

The factors which influence the migrations are comparatively well investigated and in this respect, La Bella's investigations which also have an applicable character ([4], [5] and [6]) deserve special attention. The factors expressing the differentiation of the potentiality to have different commodities, services, and facilities, have an entirely exogenous character, therefore planners can forecast them and at the same time forecast the possible decision of the population to migrate. *The objective character of the migra-*

tion factors, as previously stated, makes possible, in principle, the usage of common techniques for forecasting migration flows in both market and centrally planned economies.

Thus, it may in principle be accepted that the index  $q_{ip}$  for the propensity of the population to migrate respectively from the  $i$ -th to the  $p$ -th subregion of the region, expresses the fraction between the number of migrants and the population size in the relative subregion:

$$q_{ip}^{t+n} = \frac{M_{ip}^{t+n}}{K_p^{t+n}} \quad . \quad (9)$$

The above fraction is a function of the differences of the above mentioned factors between the subregions of the migration and the subregions of attraction which provoke differences in the expected profit for the migrants (see A. La Bella [2]):

$$q_{ip}^{t+n} = f(a, \Delta R_{ip}, \Delta C_{ip}, \Delta h_{ip}^R, \Delta h_{ip}^C, r, L_{ip}, v_{ip}) \quad , \quad (10)$$

where:

$\Delta R_{ip}, \Delta C_{ip}$  = existing differentiation in the costs and benefits of the population living in different subregions;

$\Delta h_{ip}^R, \Delta h_{ip}^C$  = expected differentiation in growth rates of the same factors;

$r$  = discount factor;

$L_{ip}$  = differentiation of the potentiality for finding work;

$v_{ip}$  = expected cost of the move.



In this regard it is necessary to stress that the differentiation of the factors for migration by subregions of the region requires that a comparison be made between the subregions of the Silistra region and specific subregions outside the region but not, as some authors propose, with the average level of the country's conditions. This is necessary because the average level of the factors of a country tends to compensate for the differences between the specific attractive subregions and reduces their real power of attraction in the model.

The further investigation of the problem requires that the place of the MM be shown in the system of regional models.

#### PLACE OF THE MM IN THE OPTIMIZATION SCHEME OF THE SYSTEM OF REGIONAL MODELS

The lack of a general concept for the system of regional models requires that only the main stages of the optimization scheme of the system of regional models be treated. Therefore, the following statement may be accepted: the optimization of separate subsystems has to be realized with constraints to the labor resources by separate subregions of the region, which are defined by the natural demographic population growth, (i.e., without population migration) defined by formula (1). The possible population movement (migration processes) has to be defined at the subsequent stage, after deriving the expected real size of the migration flows and taking into account the influence of the factors which provoke them. This makes it possible to use the MM as an independent model. On the other hand, it is possible, at the initial stage of the optimization scheme of the system of models, that a solution of the other subsystem models be found. In such a case, the surpluses of labor resources are released by subregions of the region. These surpluses influence the optimal decision of these models which is derived considering the final expenditures and efficiency concerning the movement of the labor resources within the region.

The main stages of the optimization cycle of the system of regional models with respect to the place of the migrations may be formulated as follows (see Figure 4):

*Stage 1: Elaboration of Prospective  
Regional Input-Output Model*

This model must be elaborated by starting with a basic regional input-output balance, by the limitations derived by a prospective national interregional intersectoral model, and by the population model. In this respect, the prospective regional input-output model may be represented as follows:

$$\sum_{p=1}^r \sum_{j \in J} (X_{ip}^{t+n} + Im_p^{t+n}) = \sum_{p=1}^r \sum_{j \in J} (A_{ij} X_{jp}^{t+n} + B_{ij} X_{jp}^{t+n} + Ex_p^{t+n}) + \sum_{p=1}^r (\alpha_i Z_1^{t+n} + \beta_i Z_2^{t+n}) ,$$

$i \in I , \quad j \in J , \quad p \in P ,$

(the notations are the same as in (4), but referring to n time-years prospective period).

The prospective regional input-output model has the following constraints:

$$\sum_{p=1}^r \sum_{j \in J} Im_p^{t+n} \leq \bar{I} ,$$

-- constraints for maximum import of production in region r from other regions q;

$$\sum_{p=1}^r \sum_{j \in J} Ex_p^{t+n} \geq \underline{E} ,$$

-- constraints for minimum export from region r to other regions q;

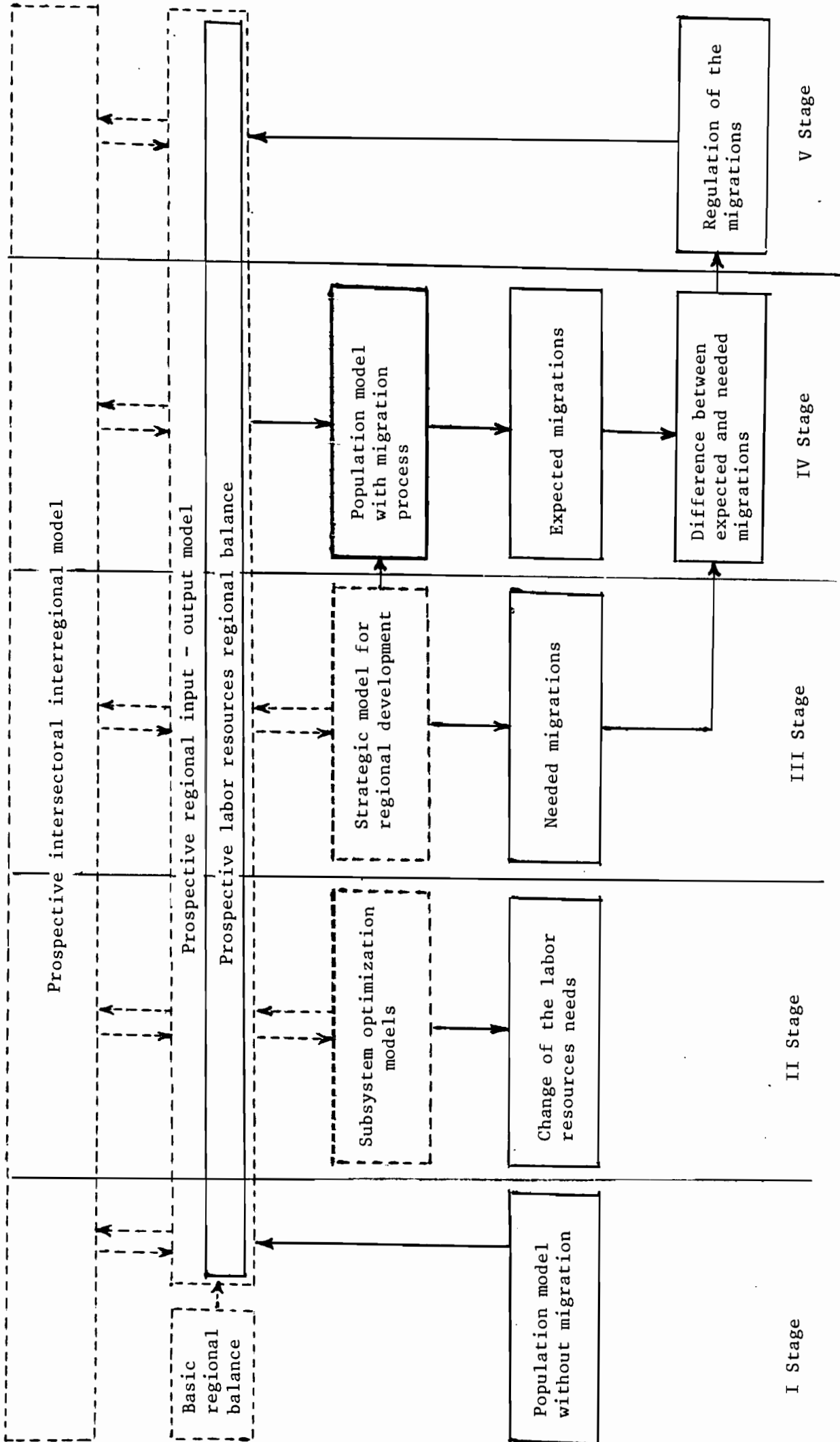

Figure 3. Optimization scheme of the system of regional models including migrations.

$$\sum_{p=1}^r \sum_{i \in I} \alpha_i z_1^{t+n} \geq \underline{H}_1 ,$$

-- constraints for minimum final personal consumption;

$$\sum_{p=1}^r \sum_{i \in I} \beta_i z_2 \geq \underline{H}_2 ,$$

-- constraints for minimum volume of production for consumption by the non-productive subsystems;

$$\sum_{p=1}^r \sum_{i \in I} A_{ij} x_{jp}^{t+n} \leq \bar{A} ,$$

-- constraints for maximum volume of material resources;

$$\sum_{p=1}^r \sum_{i \in I} B_{ij} x_{jp}^{t+n} \leq \bar{B} ,$$

-- constraints for maximum volume of capital investments;

$$\sum_{p=1}^r \sum_{i \in I} v_{mj} x_{jp}^{t+n} \leq \bar{L} ,$$

-- constraints for maximum quantity of labor force by different types of qualification and by subregions of the region. In this case the quantity of labor resources is derived by formulae (1) and (3) without taking into account the size of the migrations and of the commuting patterns;

$$\sum_{p=1}^r \sum_{i \in I} v_{mj} \gamma_i x_{jp}^{t+n} \leq \bar{V} ,$$

-- constraint for maximum gross wage.

*Stage 2: Optimization of Separate Subsystems*

The optimization may be realized using local criteria and taking into account the constraints assigned by the prospective regional model (11). Generally speaking when the separate subsystem maximizes its final income, the volume of this income may be derived by means of summing up the relative columns of the regional input-output balance and will consist of the following elements:

$$\sum_{p=1}^r \sum_{i \in I} P_j X_{jp}^{t+n} = \sum_{p=1}^r \sum_{i \in I} A_{ij} P_i X_{jp}^{t+n} + \sum_{p=1}^r \sum_{i \in I} V_{mj} \gamma_{mi} X_{jp}^{t+n} + \sigma \sum_{p=1}^r \sum_{i \in I} B_{ij} P_i X_{jp}^{t+n} \quad (12)$$

revenue	current material costs	wage costs	profit (income)
---------	---------------------------	------------	--------------------

Thus, the income of the separate subsystems will represent the difference between revenue and production costs and has to be maximized:

$$\max \left\{ \sum_{i \in I} \sum_{p=1}^r [P_j X_{jp}^{t+n} - (A_{ij} X_{jp}^{t+n} + V_{mj} \gamma_{mi} X_{jp}^{t+n})] \right\} \quad (13)$$

The optimization of the separate subsystems will result in new quantities of their elements, in the framework of the assigned constraints. They will differ from the quantities in the regional input-output model. As far as labor resources are concerned (viewed as productive resources) the difference obtained in the result of the optimization will be:

$$\sum_{p=1}^r \sum_{i \in I} V_{mj} X_{jp}^{t+n} \pm \sum_{p=1}^r \sum_{i \in I} \check{V}_{mj} \check{X}_{jp}^{t+n} = \check{L}_{mp}^{t+n} \quad (14)$$

This requires the new quantities of the subsystem elements to be included in the regional input-output model (11). It is necessary to point out, that using the input-output model for a shorter time period (up to 5 years) than the population model (up to 30 years) requires that the input-output model be updated every 5 years.

*Stage 3: Strategic-Type Model-Solving  
for Development of the Region*

We shall expose here only the outline of one feasible model of a strategic type. This model is based on the alternative development of the major productive subsystems depending on their efficiency. The alternative development is caused by the redistribution of the resources within the region (including the spatial relocation of labor resources). Hence, the optimization in the regional aspect is realized by means of criteria of higher rank, than the local criteria of the separate subsystems.

Feasible criteria of such a strategic type model may be the maximization of final personal consumption and of the consumption intended for the non-productive subsystems, on the basis of a previously defined assortment structure:

$$\max_{z_1, z_2} (\alpha_i z_1^{t+n} + \beta_i z_2^{t+n}) \quad . \quad (15)$$

The constraints are taken from the prospective regional input-output model as a result of the solving of the separate subsystem models (13). The constraints to the resources by subregions of the region (including labor resources) are not taken into account.

$$\sum_{j \in J} \check{I}_{mp}^{t+n} \leq \bar{I} \quad ,$$

$$\sum_{j \in J} \check{E}x_p^{t+n} \geq \underline{E} \quad ,$$

$$\sum_{i \in I} \check{V}_{mj} \check{X}_j^{t+n} \leq \bar{L} \quad ,$$

etc., following the constraints of (11).

The result of the strategic model-solving will be the relocation of labor resources among the subregions of the region. Their quantities will be:

$$\sum_{p=1}^r \sum_{j \in J} \left( \check{L}_{mp}^{t+n} + \check{L}_{mp}^{im.,t+n} \right) = \sum_{p=1}^r \left( v_{m1} \check{X}_{jp}^{t+n} + v_{m2} \check{X}_{jp}^{t+n} + v_{m3} \check{X}_{jp}^{t+n} + v_{m4} \check{X}_{jp}^{t+n} + \sum_{i \in I} \check{L}_{mp}^{ex.,t+n} \right) \quad (16)$$

The required quantity of migration flows originating from the above solution may be derived in the following way:

$$\sum_{p=1}^r \check{M}_{ip}^{t+n} = \sum_{p=1}^r K_p^{t+n} - \sum_{p=1}^r N_p^{t+n} - \sum_{p=1}^r \sum_{j \in J} \left( \check{L}_{mp}^{t+n} + \check{L}_{mp}^{im.,t+n} - \check{L}_{mp}^{ex.,t+n} \right) - \sum_{p=1}^r \Delta m_{ip} \quad (17)$$

where

- $\check{M}_{ip}$  = required size of migration flows from subregions i to p of the region;
- $K_p$  = population size derived by means of the Leslie model [1];
- $N_p$  = size of inactive population;
- $\Delta m_{ip}$  = additional part of the population (families) which are expected to migrate because of their relation to the labor resources movement.

The section of the model in parentheses represents the size of the labor resources [derived by formula (16) as a result of the optimization decision of strategic type models (15)].

It can definitely be claimed that the above allocation of labor resources by subregions is submitted to the requirements

of a strategic type for the development of the region, but it does not directly reflect the propensity of the population to move between the subregions of the region and out of the region. Nevertheless, the strategic decisions provoke alterations in the socio-economic conditions and in the reasons for migration. Some reasons will objectively favor the migration though, while others may restrict them. This requires the derivation of an expected quantity of migration flows.

*Stage 4: Defining the Expected Quantity of Migrants*

The expected size of migration flows might be expressed in terms of Rogers' model (2) in which the migration rates  $q_{ip}^{t+n}$  are derived by La Bella's model (10) and under the conditions consistent with the strategic type models (16).

$$\{M_{ip}^{exp, t+n}\} = G_p \{K_p^t\} \quad , \quad (18)$$

Where

$\{M_{ip}^{exp, t+n}\}$  = vector of the expected size of the net migration flow between subregions  $i$  and  $p$  for the prospective period  $t+n$ .

*The derivation of the expected size of net migration flows brings about their comparison with the so-called required size of migration flows which are provoked by solving strategic type models (17). The difference between the required migration size and the expected migration size is represented by:*

$$\sum_{p=1}^r \left( M_{ip}^{t+n} \pm M_{ip}^{exp, t+n} \right) = \Delta \sum_{p=1}^r M_{ip}^{t+n} \quad . \quad (19)$$

The specific features of the stages treated so far show that the difference (19) has to be reduced to zero when it is positive [because the expected size of migration flows is undesirable with respect of the optimal decision (15)] or to be realized in the full size when it is negative (because these



migration flows are needed with respect to the optimal decision). The problem is, however, that the provoked additional size of the migration flows or the prevention of the undesirable size of these is connected with sensitive additional expenditures out of the expenditures considered in the optimal solutions so far. *This requires that the problem of regulating migrations, in a broad sense, be treated in conjunction with the final efficiency of the migration flows.*

*Stage 5: Regulation of the Migrations*

The regulation of the migrations presents a new model of a strategic type, by taking into account the efficiency and the expenditure additionally and directly provoked by the migration flows. In this case, a criterion of higher rank has to be used which meets both the requirements for the development of the region, and the incentives of the people who make decisions to migrate. But prior to answering the question of how to regulate the migrations, it is necessary to prove which migration flow is to be regulated in order to be effective. The answer to the latter question is predetermined by the above stages of the optimization scheme. From the optimization process, we can see that this is a part of the required migrations which is covered by the expected migrations (the first is calculated by means of the strategic-type model at stage 3), and hence we can claim that this part is effective. *To answer the question whether the difference between the required and the expected migrations is effective, it is necessary to make an assessment of the efficiency of this difference.*

The following more general formulation of migration efficiency may be adopted: a given additional size of migration flow is effective in the regional framework when the difference between the additional income and costs per capita provoked by these migrations exceeds, or is equal to, the net income per capita as calculated at the previous stages of the optimization scheme:

$$\sum_{p=1}^r \sum_{i \in J} \frac{\Delta Q_{ip}^{t+n} - \Delta C_{ip}^{t+n}}{\Delta M_{ip}^{t+n}} \geq \sum_{p=1}^r \sum_{j \in J} \frac{v_{jp}^{t+n} + B_{ij} x_{jp}^{t+n}}{K_p^{t+n}}, \quad (20)$$

where

$\Delta Q_{ip}$  = additional income from migrations expressing the difference between income created in subregions i and p of the region as a result of different labor productivity.

$$\Delta Q_{ip} = Q_p - Q_i \quad , \quad (21)$$

where

$\Delta C_{ip}$  = additional expenditures for migrations which express:

$\Delta C_{ip1}$  = the expenditures for living space,

$\Delta C_{ip2}$  = additional expenditures for municipal services,

$\Delta C_{ip3}$  = additional expenditures for education

$\Delta C_{ip4}$  = additional expenditures for the development of health care services,

etc., and additional expenditures (salary or other facilities) which will provoke the propensity to migrate =  $\Delta C_{ipn}$ . Generally:

$$\Delta C_{ip} = \Delta C_{ip1} + \Delta C_{ip2} + \dots + \Delta C_{ipm} + \Delta C_{ipn} \quad , \quad (22)$$

where

$V_{jp}$  = gross wage within the region;

$B_{ij}X_{jp}$  = realized profit within the region.

Thus, the optimal size of the migration flows  $\Delta M_{ip}^*$  must be derived when the marginal additional value of the income (I) as a result of the migrations is equal to the marginal expenditures (E) provoked by the migrations:

$$\frac{dI}{dE} = 0 \quad . \quad (23)$$

In the case when the effectiveness of the additional size of migrations  $\Delta M_{ip}$  is claimed, a problem of the regulation of these migrations arises. I.e., it is necessary to create conditions which will transfer the expected migration flows (18) into the required migration flows (17) which is necessary to the optimal decision (15).

The problem may be solved on the basis of La Bella's model (10) in which the additional value  $\Delta C_{ipn}$  has to be added with the aim of provoking the additional migrations in size  $\Delta M_{ip}$ . In this case La Bella's model for forecasting migration flows may be transformed in the model for migration regulation.

$$K_p^{t+n} \cdot q_{ip} + \Delta M_{ip}^{*t+n} = f(a, \Delta R_{ip}, \Delta C_{ip}, \Delta h_{ip}^R, \Delta h_{ip}^C, r, L_{ip}, \gamma_{ip}, \Delta C_{ipn}) \quad (24)$$

As shown above, the additional value  $\Delta C_{ipn}$  which plays the role of regulator of the migrations exists also in formula (21) for the efficiency of the additional size of migration. This ensures convergence between the efficiency of the migrations and their regulation.

The quantity of the additional value  $\Delta C_{ipn}$  may be derived by solving the reverse function regarding  $\Delta C_{ipn}$ :

$$\Delta C_{ipn} = f(\Delta M_{ip}^*, a, \Delta R_{ip}, \Delta C_{ip}, \Delta h_{ip}^R, \Delta h_{ip}^C, r, L_{ip}, \gamma_{ip}) \quad (25)$$

Introducing  $\Delta M_{ip}^* = \text{const.}$  in the above function, it is possible to obtain the required value of  $\Delta C_{ipn}$  which will provoke the necessary migrations  $\Delta M_{ip}$ .

#### BASIC CONCLUSIONS AND REQUIREMENTS

1. The elaboration of the system of regional models requires the investigation, on the one hand, of the factors which influence the migrations and, on the other, the reverse influence of the migrations on the development of other subsystems of the region.
2. The migration modeling seems to be similar in centrally planned and market economies.
3. In the population model including the migrations (2) it is necessary to differentiate the population by age groups. Basic subregions of the population allocation must necessarily be introduced.
4. In the basic regional input-output balance (4) and the prospective regional input-output model (11) the main sectors and activities have to be differentiated by subregions of the region. The consumption has to be also differentiated by subregions of the region.
5. In the basic regional balance of labor resources (5) and in the prospective balance of labor resources (16) the allocation of labor resources has to be differentiated by subregions of the region, by qualification types and by subsystems.
6. The differentiation of the conditions reflecting the reasons for migration (10) is necessary to be made by main subregions of the region and by concrete subregions outside the region, but not by average conditions for the country.

7. The interdependency between the models of the separate subsystems (in horizontal line), and their links with the regional input-output model and with the strategic-type models (in vertical line), requires that the efficiency of the migrations and their regulation be also realized in horizontal and vertical lines. Hence, the full scheme of modeling of the migrations has to be treated as a hierarchical system of models of two levels.
8. Defining the required size of the migration flows (adequate to the optimal decisions of the other subsystems) and defining the expected size of the migration flows (adequate to the incentives of the population) are key problems of the migration modeling. The difference between the required and expected size of migration flows raises the problem of their regulation.

REFERENCES

- Albegov, M et al. (1977) Models and Algorithms in Solving Tasks of Production Relocation (in Russian). Moscow, USSR.
- Keyfitz, N. (1968) Introduction to the Mathematics of Population. Addison Wesley edition.
- Kulikowski, R. (1978) Regional Development Modelling: Labor, Investments and Allocation Policy Impact. Paper presented at the Notec Task Force Meeting I. RM-78-40. Laxenburg, Austria: International Institute for Applied Systems Analysis.
- Frick, P.A., and A. La Bella (1977) Models of Spatial Population Dynamics in Italy. R-77-01. Istituto Automatica, Università di Roma.
- La Bella, A. (1978) A possible Approach to the Analysis of Migration and Commuting Patterns in Bulgaria (Silistra Region). Laxenburg, Austria: International Institute for Applied Systems Analysis. Forthcoming.
- La Bella, A. et al. (1977) Dynamic Modelling in Development Planning. Applied Mathematical Modelling 1, December. Rome, Italy.
- Willekens, F., and A. Rogers (1976) Computer Programs for Spatial Demographic Analysis. RM-76-58. Laxenburg, Austria: International Institute for Applied Systems Analysis.

APPENDIX

OBSERVED POPULATION CHARACTERISTICS, 1975

INPUT-DATA

REGION	SILISTRA				
AGE	POPULATION	BIRTHS	DEATHS	MIGRATION FROM SILISTRA TO SILISTRA R.OF.BUL	
0	14686.	0.	110.	0.	84.
5	15096.	0.	4.	0.	77.
10	14657.	4.	4.	0.	360.
15	12182.	509.	0.	0.	437.
20	13125.	1461.	14.	0.	178.
25	13950.	851.	16.	0.	86.
30	13784.	277.	17.	0.	55.
35	11579.	57.	19.	0.	31.
40	11842.	16.	30.	0.	21.
45	11577.	7.	45.	0.	14.
50	11590.	0.	82.	0.	10.
55	6707.	0.	76.	0.	5.
60	8815.	0.	160.	0.	5.
65	7166.	0.	235.	0.	4.
70	4998.	0.	259.	0.	3.
75	2621.	0.	262.	0.	2.
80	1193.	0.	191.	0.	1.
85	859.	0.	189.	0.	1.
TOTAL	176428.	3192.	1719.	0.	1374.

AGE	POPULATION	BIRTHS	DEATHS	MIGRATION FROM R.OF.BUL TO SILISTRA R.OF.BUL	
0	652871.	0.	3834.	57.	0.
5	622846.	0.	316.	38.	0.
10	612405.	234.	270.	225.	0.
15	626311.	23140.	449.	270.	0.
20	642213.	63824.	609.	120.	0.
25	676309.	37900.	696.	57.	0.
30	563856.	11786.	725.	29.	0.
35	551814.	3589.	1006.	19.	0.
40	622908.	898.	1626.	7.	0.
45	621155.	70.	2663.	5.	0.
50	603537.	0.	3981.	3.	0.
55	364560.	0.	3650.	3.	0.
60	440850.	0.	7578.	3.	0.
65	384096.	0.	11335.	1.	0.
70	277711.	0.	14200.	1.	0.
75	166260.	0.	14353.	1.	0.
80	73784.	0.	10461.	1.	0.
85	47851.	0.	10353.	1.	0.
TOTAL	8551337.	141437.	68255.	841.	0.

MULTIREGIONAL POPULATION PROJECTION  
 \*\*\*\*\*

POPULATION	YEAR 1975		
AGE	TOTAL	SILISTRA	R.OF.BUL
0	667557.	14686.	652871.
5	637942.	15096.	622846.
10	627062.	14657.	612405.
15	638493.	12182.	626311.
20	655339.	13126.	642213.
25	690259.	13950.	676309.
30	577640.	13784.	563856.
35	563393.	11579.	551814.
40	634750.	11842.	622908.
45	632732.	11577.	621155.
50	615127.	11590.	603537.
55	371267.	6707.	364560.
60	449665.	8815.	440850.
65	391262.	7166.	384096.
70	282709.	4998.	277711.
75	168881.	2621.	166260.
80	74977.	1193.	73784.
85	48710.	859.	47851.
TOT	8727765.	174428.	8551337.



POPULATION	YEAR 2020		
-----	-----		
AGE	TOTAL	SILISTRA	R. OF. BUL
0	753311.	15214.	738098.
5	730968.	14721.	716247.
10	725165.	14361.	710804.
15	719218.	13627.	705591.
20	702144.	12912.	689232.
25	679837.	12584.	667253.
30	666945.	12370.	654576.
35	665813.	12149.	653664.
40	664930.	12191.	656739.
45	621012.	11464.	609548.
50	586973.	11521.	575452.
55	554844.	10949.	543895.
60	529308.	9210.	520098.
65	485839.	9103.	476736.
70	422094.	8009.	414085.
75	254543.	5558.	248986.
80	144674.	2540.	142134.
85	98236.	1441.	96795.
TOT	10009855.	189923.	9819932.

## MODELING THE HEALTH CARE SYSTEM

E.N. Shigan, D.J. Hughes  
and P.I. Kitsul

### INTRODUCTION

The goal of the bio-medical task is to develop a national health care system model (NHCS) in collaboration with national research teams. Such a model will help decision makers on a national level to consider different versions of planning decisions and to choose the best alternative from their point of view. Moreover, developing a HCS model on the basis of the generalization of the international experience will be a good methodological tool for development of mathematical models for other hierarchical levels of health care system.

The starting point of the HCS Modelling Task is well summarized by the following observation of its first leader.

Health care is a complex social dynamic functional system created and used by society for carrying out social and medical measures for protecting and improving health and for the continuous accumulation of medical knowledge (Venedictov, et al., 1977).

In Figure 1 we can see that both internal and external parts of the health care system may be divided into interrelated subsystems.

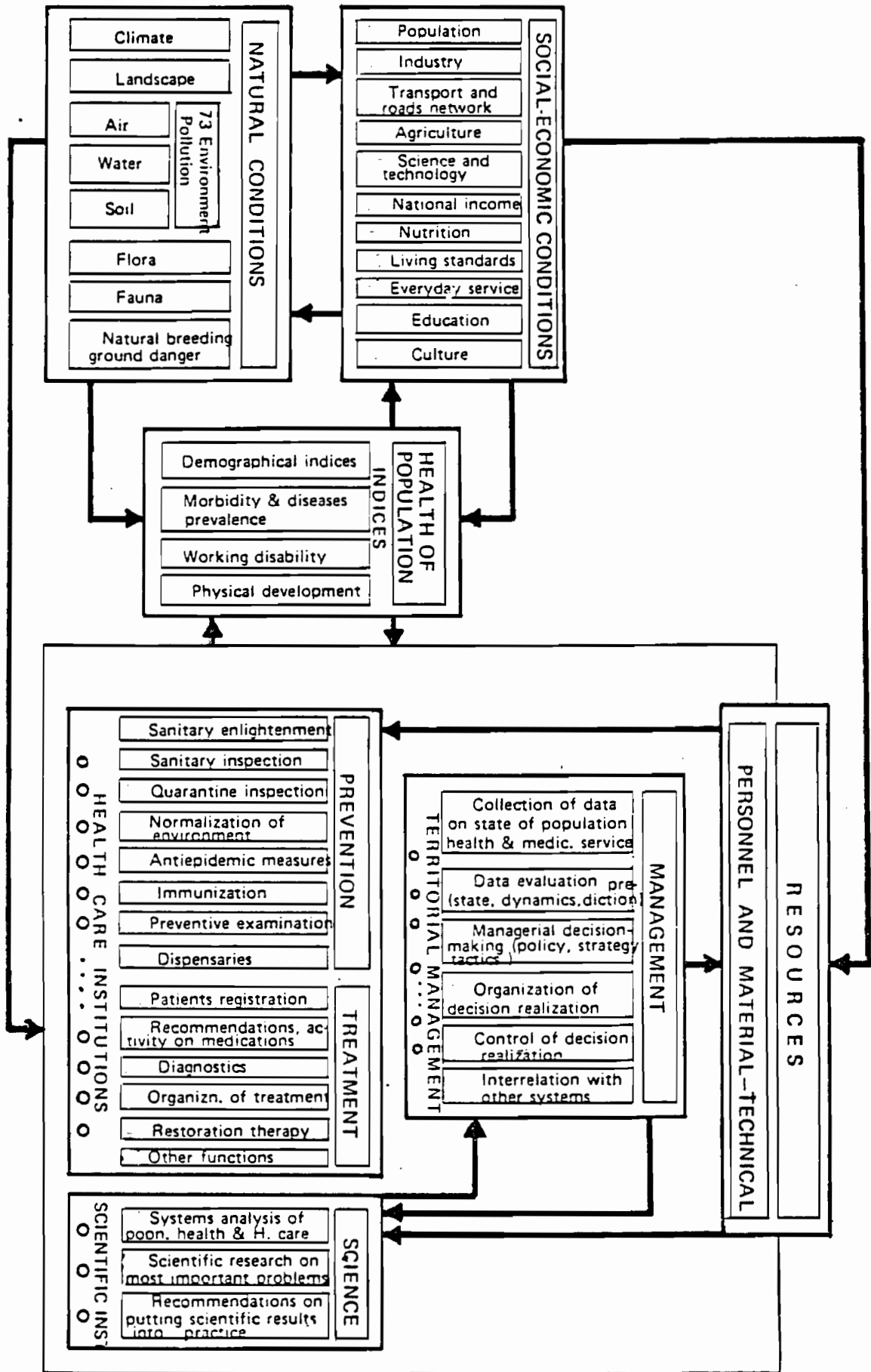

Figure 1. Functional chart of a public health system.

Source: Venedictov (1977).

## MODELING APPROACH

### *Health Care Systems*

Health care systems have certain features which distinguish them from the more common engineering systems investigated by mathematical modelers. Here we show how these features have influenced our approach to model building, and we summarize the conceptual framework and methods which we have used.

What is special about health care system?

- The health care system is a social system. Its behavior reflects the participation of individuals such as patients, doctors, health managers, and their interrelations with external systems.
- The HCS is often organized *hierarchically*. Not only are the systems in particular regions often managed separately, there is usually some specialization according to the severity of disease.
- The HCS is *dynamic*. The number of doctors available today depends upon the training policy of five to six years ago, and society's health today may depend upon the activity of the HCS during the last half century.
- The main result of HCS activity--the health status of population--can only be estimated by a set of interrelated quantitative and qualitative indices.
- Almost nothing in the HCS blocks can be subjected to experiments, even at local levels.
- There are some specific communication problems between the decision maker and the model builder, caused by different educations, experiences and approaches to the solution of real health care problems.
- Existing medical data bases are adapted mainly to classical medical statistical aims of different policies in health care systems management.

In summary, from the point of view of mathematical modeling, the HCS is a complex, hierarchical, dynamic, large-

scale system with a number of quantitative and qualitative criteria and with incomplete and indirect observations. At the present time problems in such systems are solved by decision makers on the basis of their personal experience. We believe that the HCS modeling activity will not only assist the present decision process but also will help to improve existing methods of long-term planning.

Figure 2 depicts our general approach to model building. We have divided this scheme between the creation and the use of models to emphasize the importance of each step of work. In general our modeling activity is oriented to the right side of this scheme, but this fact does not prevent us from creating and using models in different ways in different particular situations.

Figure 3 summarizes the outcome of this process. It represents one part of the larger system shown in Figure 1: namely, the processes by which people fall ill and by which health resources are provided and used for their treatment. This model also summarizes the system of submodels constructed by the IIASA HCS Modelling Task up to 1978. There are five groups of submodels. *Population* projections are used by *morbidity* models to predict true health needs. Such estimation of needs can be used either to estimate *resource requirements* at a certain normative level, or they can be partially satisfied according to a *resource allocation* model which has some inputs from a *resource supply model*. The areas of choice for the decision maker include his policies, standards, and performance indicators. Beyond the HCS boundary are the external systems of environment and economy.

#### *A Mixed Modeling Strategy*

Our 1977 review of mathematical models (Fleissner and Klementiev, 1977) distinguished between models according to their modeling techniques: macroeconomic, systems dynamic or optimization. But mathematical models have since become more sophisticated, and such a classification is less useful

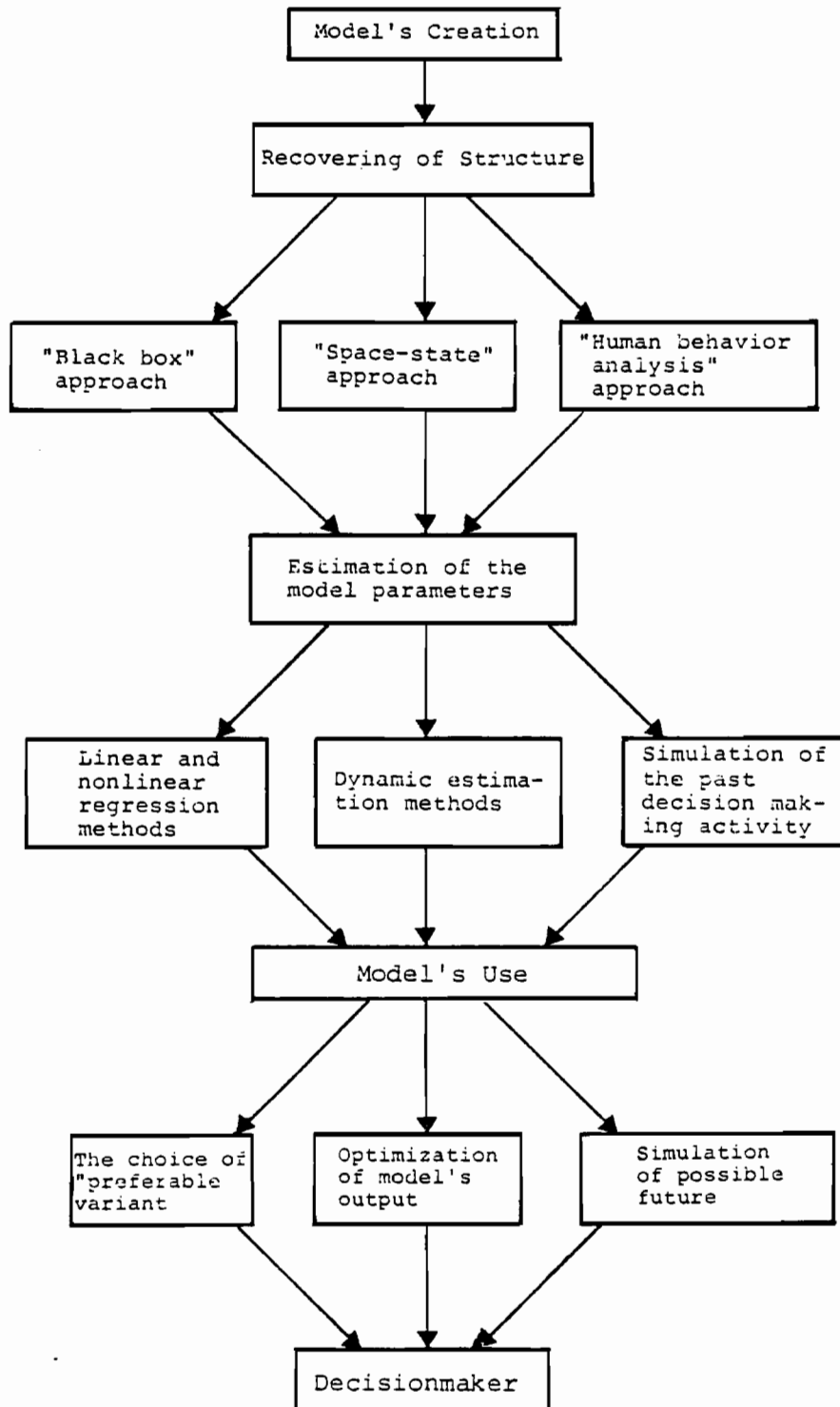

Figure 3. Different stages of modeling.

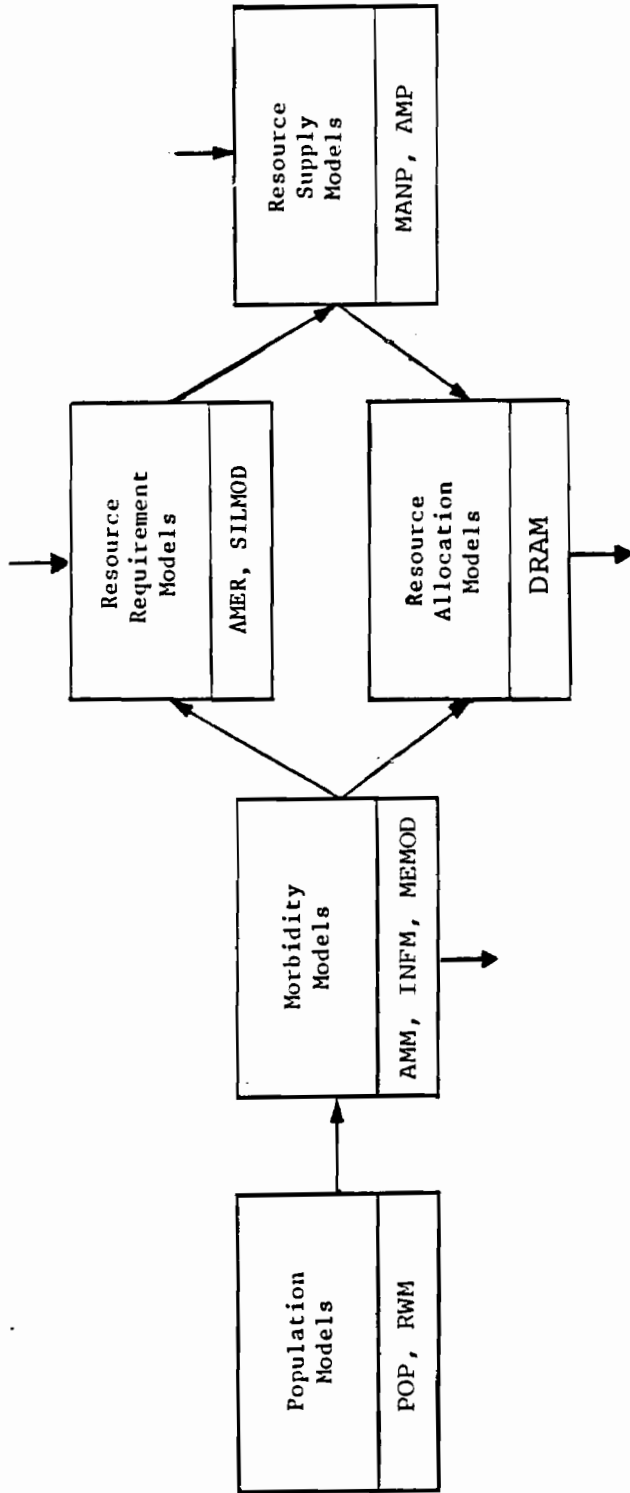

Figure 3. Family of Health Care System submodels.

From our point of view, it is more useful to distinguish models according to the aims of the modeling or the tupe of use. Accordingly, we can divide HCS models into two groups: simulation models and optimization models.

As Yashin and Shigan (1978) and Figure 2 indicate, there are different stages of modeling for both of these approaches: recovering of structure, estimation of the model parameters, and model use. Moreover, one can use different mathematical methods in either type of model. As an example, in the creation of any optimization model, before using the special optimization technique, it is necessary to have the *model of the system*, to *estimate its parameters* and to carry out *sensitivity analyses*, i.e., to build a simulation model. On the other hand, in some simulation models it is necessary to simulate human behavior, and it is natural to use for this aim the *utility function* and some *optimization technique* to recover the input-output interrelation of the system.

We can illustrate this mix of approaches in the IIASA HCS models. Our morbidity estimation models are state-space structured simulation models but incorporate no element of human behavior and no optimization technique. The resource requirement models also do not use any optimization technique but simulation models permit the choice of the "most preferable" resource allocation. Our resource allocation model is also a simulation model, but in order to simulate some element of human behavior it assumes that the human agents in the system act as if they were maximizing a utility function. Lastly, the manpower education and training model is an optimization type model, although application of the dynamic linear programming technique presupposes a successful simulation using the state-space approach.

#### STATE-OF-THE-ART IN HCS MODELING AT IIASA

##### *Models for Demographic Projection*

It is obvious that the dynamics of mortality rates and, hence, morbidity rates themselves are correlated with the



dynamics of demographic age pyramid, and that this correlation is a different registered morbidity rate, changing very slowly over time in comparison with the dynamics of age structure. Evidently, therefore, models for morbidity prediction must be age-specific and indeed all of our submodels need information about population.

In some applications it is possible to use population projections provided by national agencies with specific responsibility for such work. For other applications we have two separately developed models. The first is a model for projecting a population structure on the level, Klementiev (1976). The second model of Willekens and Rogers (1976) uses spatial demographic data and can be used, not only on the regional (multiregional) or national level, but also for more precise projections of population, because it uses more detailed information about fertility and mortality rates in the different regions and includes multiregional migrations. The population forecasts were used in the Aggregate Model for Estimating HCS Resource Requirements AMER (Klementiev and Shigan, 1978) and in other IIASA HCS models.

#### *Morbidity Models*

The problem of estimating trends in health indices is one of the serious problems in all countries, and much attention has been given to it by the WHO. The WHO and others have used a number of indices, all of them roughly divided into groups-- demographics, morbidity, physical development, etc. All these indices taken independently could estimate the health status only partly. The combination of all these rates reflects much more accurately the health status of the population.

Because collection and identification of all possible individual information is desirable, many developed countries are working now to organize computer registers containing complete medical and non-medical individual information. The organization of such banks of information seriously depends on solving several problems such as the technical capacity of

present and future computer facilities, standardization and formalization of all existing medical records, and confidentiality.

Unfortunately, these problems have at present not been solved anywhere, and in developed countries dynamic computer registers are being created only for small localities or to cover parts of the population. Because all these experiments are proceeding according to very limited aims and have only just started, the main sources of complete information about the health of the population in many developed countries are special comprehensive studies in a sample locality during a fixed period of time. Such comprehensive studies, repeated over several years, allow us to estimate trends in health indices for different groups of the population.

In some countries where problems of confidentiality of personal medical information are too serious, the results of such a study are practically unavailable or can be used only by limited groups of specialists. In other countries all this information is available for different scientific purposes, including the modeling of health care systems. In the IIASA group, where scientists are working from different countries, the lack of information in one country can be compensated for by information taken from other countries. Because there are many sources of morbidity data in each country, differing in coverage and accuracy, the procedure of estimating morbidity rates becomes more difficult and requires mathematical description. The development of such mathematical models would have the following effects:

- In countries where there has been difficulty in obtaining and generalizing personal medical information, only simplified processes would be required and the associated problems would be reduced.
- In other countries the application of these mathematical methods would bring about a decrease in the number of expensive studies.
- For all countries these models would help in forecasting health status and medical resource

requirements on the basis of a universal system methodology.

Different alternatives exist for estimation morbidity rates using the information available in different countries (Shigan, 1977). Such models can be divided by their degree of detail into the following types:

- *aggregative morbidity models*, which estimate and forecast "crude" general morbidity rates without specifying specific diseases or groups of diseases,
- *group morbidity models*, which model groups of diseases, i.e., the classes in the International Classification of Diseases (ICD), or the groups used in several IIASA publications (degenerative diseases, infections, accidents, etc.),
- *specific morbidity models*, which consider specific diseases (e.g., cancer, cholera, tuberculosis, etc.) and
- *stage of disease models*, which look not only at a specific disease, but also at the different stages of its development and at risk-group estimation and classification.

Together with a number of national centers, and also using the statistics of the WHO, we have designed and constructed three computer models:

- for estimation of aggregative morbidity rates,
- for estimation of morbidity rates for infectious diseases, and
- for estimation of morbidity rates for terminal degenerative diseases.

#### Aggregative Morbidity Model

As mentioned above, data about morbidity and its trends can, with a certain amount of difficulty, be taken from real comprehensive studies conducted periodically in some developed countries. But since there are only slight variances among aggregate morbidity rates, aggregate mortality rates, and the rations between them (risk rations) over time, it is possible

to estimate roughly aggregate morbidity data using mortality data from official vital statistics and the risk from such studies. The model uses as input the age-specific mortality rate, a forecast of the population age structure and the age-specific risk ratio. The central assumption of the model is that risk ratios are constant in time. As output the model forecasts age-specific morbidity. This model was used as an auxiliary morbidity submodel in the AMER model described by Klementiev and Shigan (1978) and in the section below on Health Resources Requirement Models.

#### A Morbidity Submodel of Infectious Diseases

This model was designed by Fujimasa et al. (1978). The aim of the model is the estimation of age-specific prevalence and death rates per total population for two groups of infectious diseases: epidemic diseases (ICD A1-A44), and diseases of the respiratory system (ICD A89-A96). On the basis of some standard rates which one can easily obtain from domestic health statistics, it is possible to estimate the prevalence rate, disease specific death rates per capita, and mean length of stay in the sick state, under the assumptions that mean length of stay in the sick state is less than one year and prevalence is constant over time. In accordance with the model's first assumption, the ageing of sick individuals during the duration of the disease is not taken into account. On the other hand, the second assumption implies that prevalence does not oscillate during this time. It means that this model itself is static and its technique is static analysis, but that the output of the model can be dynamic if one of the model's inputs, for example, population structure, is changing over time.

To test the validity of the model, we applied it to the data of Japan and compared the results for various countries: Finland, Austria, Sweden, England, Japan, and France. The results of application show that the model can predict the fundamental part of infectious diseases, and that this type of approach is feasible in health planning.

## Morbidity Models of Degenerative Diseases

Degenerative diseases are inherent to human beings. They are caused by the ageing process, and the morbidity rate in these diseases usually increases with age. In our work, we have defined three groups of diseases as degenerative: cardiovascular disease (ICD A80-A88), malignant neoplasms (ICD A45-A60), senile deaths and deaths from unknown causes (ICS A136-A137). Unlike infectious diseases, degenerative diseases have slower dynamics, and so we must take into account not only the population structure and its changes, but also the individual dynamic property of each specific diseases.

In the IIASA morbidity models for degenerative diseases, different assumptions and techniques are used. Nevertheless, we shall try to describe these problems in a unified form. For this, we shall indicate the main data that we can use to estimate the morbidity of degenerative diseases on the basis of mortality statistics. These data are:

- the age distribution of *specific* mortality rates and their dynamics over time;
- the age distribution of *general* mortality rates and their dynamics over time;
- survival characteristics which describe in some sense the dynamics of disease, e.g., the proportion of individuals who were afflicted with a given disease at a certain time and age, and who did not die within a certain time interval; and
- the population's age-structure and its dynamics.

It is possible to describe mathematically the dynamics of the process "health sickness death" by integral equations that link the statistical data listed above with morbidity rates and prevalence distributed by age. Many morbidity estimation problems can be formulated in these terms, but the HCS modeling activity in this field is focused on one particular problem:

- how to estimate prevalence distributions and morbidity rates from general and specific data, survival probabilities, and population age-structures?

Because the quality of data is not the same in all countries, different assumptions about survival were used in the two IIASA morbidity models. In the first IIASA model of this type (Kaihara et al., 1977), the following assumptions were used:

1. All variables are independent of time.
2. Sick people suffering from degenerative diseases are considered as sick for the duration of their lives.
3. Persons who become ill will inevitably die at a certain definite time after contracting the disease. The duration of illness ( $T$ ) is dependent only on the type of disease.

In accordance with these assumptions, the model uses as input the population age-structure, the durations of illness, and the death rate according to cause specified by age, to give as output the age-specific morbidity rate, and the age-specific prevalence rate.

In comparison with the first model, assumption c in the second IIASA degenerate morbidity model (Klementiev, 1977) assumes that persons who become ill at time  $t$  can die at time  $t + \tau$  with probability  $P(t, \tau) = P(t - \tau)$ , and the possibility of death from other causes is not equal to zero. This model needs some inputs additional to those of the first model. They are death rates specified by age, for all causes, and the survival probabilities  $S(t - \tau) = 1 - P(t - \tau)$  obtained from clinical experience. This new assumption is more realistic than assumption c in the first model but complicates the model's structure. Nevertheless, the estimate of prevalence and morbidity rates can be obtained as the solution of a sequence of systems of linear equations.

Estimation of malignant neoplasm prevalence was carried out for Austria, Bulgaria, France, and Japan. The direction of the development of the morbidity models is toward reducing the number of restrictions on population structure dynamics and disease dynamics. For example, we require a morbidity model for unstabel and unstationary population structures.

In addition, it is necessary to adapt these models to use comprehensive health study data about a specific region, to avoid the inevitable error of extending clinical survival data to the latent sick individuals. Both those aspects are studied at the present time.

*Health Resources Requirement Models*

The IIASA HCS Modeling Group is developing several models for health resources requirements using the experience of different countries in this field. As a first step we have started from a normative planning approach. On the basis of this approach, knowledge is obtained from data about population, health status, present levels of care, their dynamics, and of how health conditions are converted into health resources. Standards can then be calculated for the number of out-patient visits per capita, the duration of one out-patient visit (in minutes), the number of out-patient visits per patient with a specific disease, etc., and for similar measures associated with other forms of care.

It is clear that the quantitative level of these standards indeed reflects the real situation of each country and differs greatly from country to country. That is why we have started with commonly used standards such as average length of hospital stay, bed occupancy rate, and bed turnover interval.

Two models have so far been developed at IIASA: AMER, Aggregative Model for Estimating Resource Requirements (Klementiev and Shigan, 1978), and SILMOD, Sick Leave Model (Fleissner, 1978). The basic structure of AMER and SILMOD is represented in Figures 4 and 5. As shown in these figures, the main difference between AMER and SILMOD consists in the methods of morbidity estimation and in the population groups which are taken into account in each model. To calculate out-patient doctor equivalent requirements in the AMER model, the substitution effect should be taken into account: the lower the hospitalization and the shorter the average length of stay, the greater is the number of consultations per episode. The

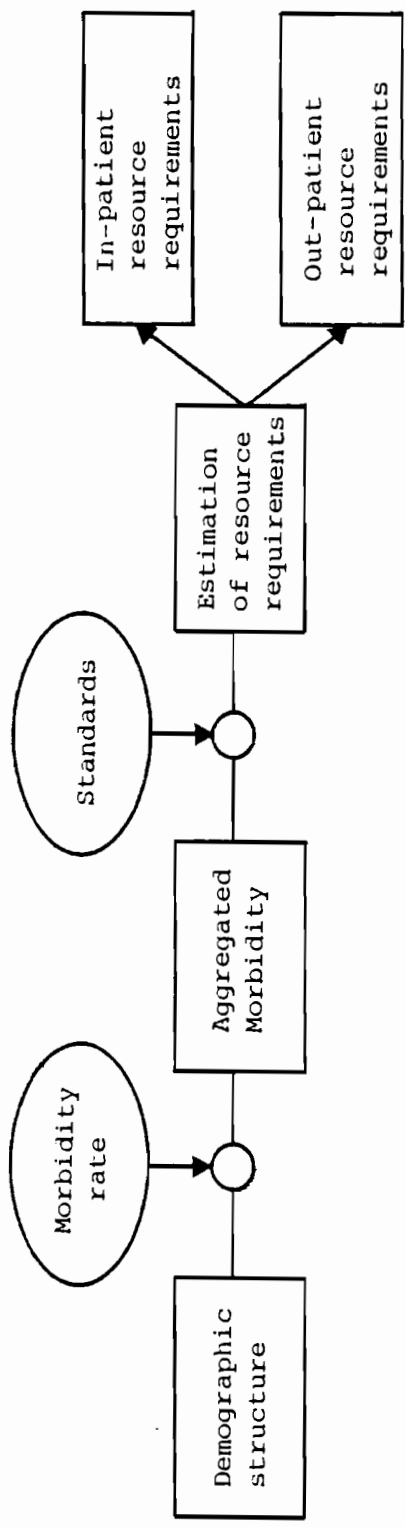

Figure 4. Basic structure of AMER.

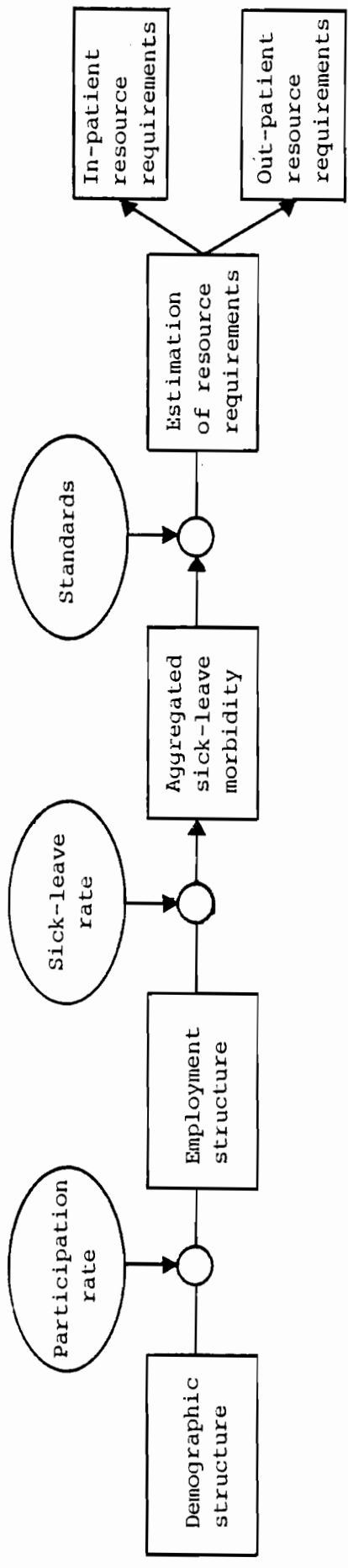

Figure 5. Basic structure of SILMOD.



main assumptions of AMER are linearity and stationarity of the substitution effect. In the SILMOD model, the substitution effect is not taken into account. However, both models assume stationary prevalence rates (or risk ratios and sick leave rates) over time.

The resource requirement models will help the national level decision maker, working in an interactive regime, to test different policy options and to select the best among them. A model also makes it possible to forecast population structure changes and mortality and morbidity trends which are very important to health care.

Although these models are designed for forecasting aggregate health resources, in some cases they can be used for specific classes of disease with precise medical resources.

#### *Health Resource Allocation Models*

DRAM is an acronym for Disaggregated Resource Allocation Model. This model was proposed by Gibbs (1978) and subsequently developed by Hughes (1978). In the conceptual framework shown in Figure 3, the resource allocation model lies between the estimation of ideal resource levels and the prediction of available resource levels. It seeks to represent how the HCS allocates limited supplies of resources between competing demands.

In every country, doctors have clinical control over the treatment of their patients, and it is local medical workers who ultimately determine how to use the resources (e.g., hospital beds, nursing care) which are available to them. The specific question underlying DRAM is:

If the decision maker provides a certain mix of resources, how will the HCS allocate them to patients?

DRAM takes input data on demand and supply, uses an hypothesis about how allocation choices are made, and gives indicators of the predicted behavior of the HCS. The demand inputs are: the total number of individuals who need treatment

by category (from the morbidity and population submodels), the policies for treatment (i.e., the feasible models of treatment for each patient category--in-patient, out-patient, domiciliary, etc.), and the ideal quotas of resources needed in each patient category and mode of treatment. The supply inputs are the amounts of resources available for use in the HCS, and their costs (from the resource supply production model). The model outputs represent the levels of satisfied demand in a HCS limited resources. They are: the number of patients of different categories who receive treatment, modes of treatment offered, and the quotas of resources received by each patient in each mode of treatment. Inevitably these levels fall short of the ideal demand levels. DRAM models the different equilibria which the HCS must choose in order to balance supply and demand. These results can be used by health planners to explore the consequences of alternative policies for resource production, treatment, and prevention.

The model has been established in Berlin, London, Montreal, and Munich, and one of these groups has run DRAM with nearly 100 disease categories, reporting a very efficient solution.

#### *Application Experiments*

Application-oriented IIASA HCS modeling activity has two directions. The first is the testing of our models on the national or regional statistics of different countries--Japan, CSSR, UK, USSR, Bulgaria, GDR, FRG, France, Austria--both by the IIASA HCS team and by collaborating scientific teams in these countries. Some results of this work have been described in earlier sections.

Since IIASA HCS models are intended also for possible interactive remote use by decision makers at regional, national or international levels, the second direction is the experimental establishment of dial-up computer links between IIASA and the offices of the decision makers. This experimental work is being carried out in close cooperation with the IIASA computer network group, who conceived the general framework for such

operations (Computer Science Group, 1978).

#### CONCLUSIONS

In conclusion, it is necessary to emphasize that all submodels developed can be used for modeling health care systems on the regional level. With the help of these submodels and the Silistra region information, it is possible to forecast population structure tendency and trends in morbidity rate level, to estimate the health resources requirement, and to test several planning alternatives of health resources allocations. In order to help in developing a simulative model of the Silistra region health care system, the IIASA biomedical group need various informations as official "routine" data as well as the results of different sample studies conducted in Bulgaria during the last ten years.

It would also be very useful to organize a permanent link between the two computer centers at IIASA and at the Bulgarian Ministry of Health, which would simplify exchange of information, models and computer programs.

REFERENCES

- Venedictov, D.D., et al. (1977) Health Care: A Systems Approach, in D.D. Venedictov (ed.), Health Systems Modeling and the Information System for the Coordination of Research in Oncology. CP-77-04. Laxenburg, Austria: International Institute for Applied Systems Analysis.
- Venedictov, D.D. (1976) Modeling of Health Care Systems. Proceedings of 1976 IIASA Conference, May 10-13, 1976. Vol. 2. Laxenburg, Austria: International Institute for Applied Systems Analysis.
- Fleissner, P. and A. Klementiev (1977) Health Care System Models: A Review. RM-77-49. Laxenburg, Austria: International Institute for Applied Systems Analysis.
- Yashin, A.I. and E.N. Shigan (1978) Problems of Modeling and Decision Making in Health Care. WP-78-21. Laxenburg, Austria: International Institute for Applied Systems Analysis.
- Klementiev, A. (1976) Computer Method for Projecting a Population Sex-Age Structure. RM-76-58. Laxenburg, Austria: International Institute for Applied Systems Analysis.
- Willekens, F. and A. Rogers (1976) Computer Programs for Spatial Demographic Analysis. RM-76-58. Laxenburg, Austria: International Institute for Applied Systems Analysis.
- Shigan, E.N. (1977) Alternative Analysis of Different Methods for Estimating Prevalence Rate. RM-77-40. Laxenburg, Austria: International Institute for Applied Systems Analysis.



A MODEL FOR THE DEVELOPMENT OF  
THE AGRO-INDUSTRIAL  
COMPLEX "DRASTAR"

G. Gavrilov, S. Stoikov,  
H. Milenkov, and A. Kehaiov

The development of agriculture on the territory of Silistra is one of the most substantial aspects of economic development of the region. Analysis of the existing state shows that economic and social processes occurring in agricultural production are important determinants of the social and economic development of the region.

Arable lands on the territory of the region are managed by the agro-industrial complex "Drastar". A significant part of the industry manufacturing products used by agriculture also belongs to the complex. The complex manages 150,000 hectares of arable land and large production funds. In accord with the tendencies for specialization and concentration of agriculture, the complex specializes in grain production and stock breeding. Most important in final production is stock breeding and its by-products (Figure 1).

Those premises make the problem of agricultural development research particularly interesting, up-to-date, and important. A series of firms have shown a desire to develop certain aspects of the future growth of the complex. The system proposed by "Globe Services International" from Chicago is rather comprehensive. Without analyzing the benefits and shortcomings

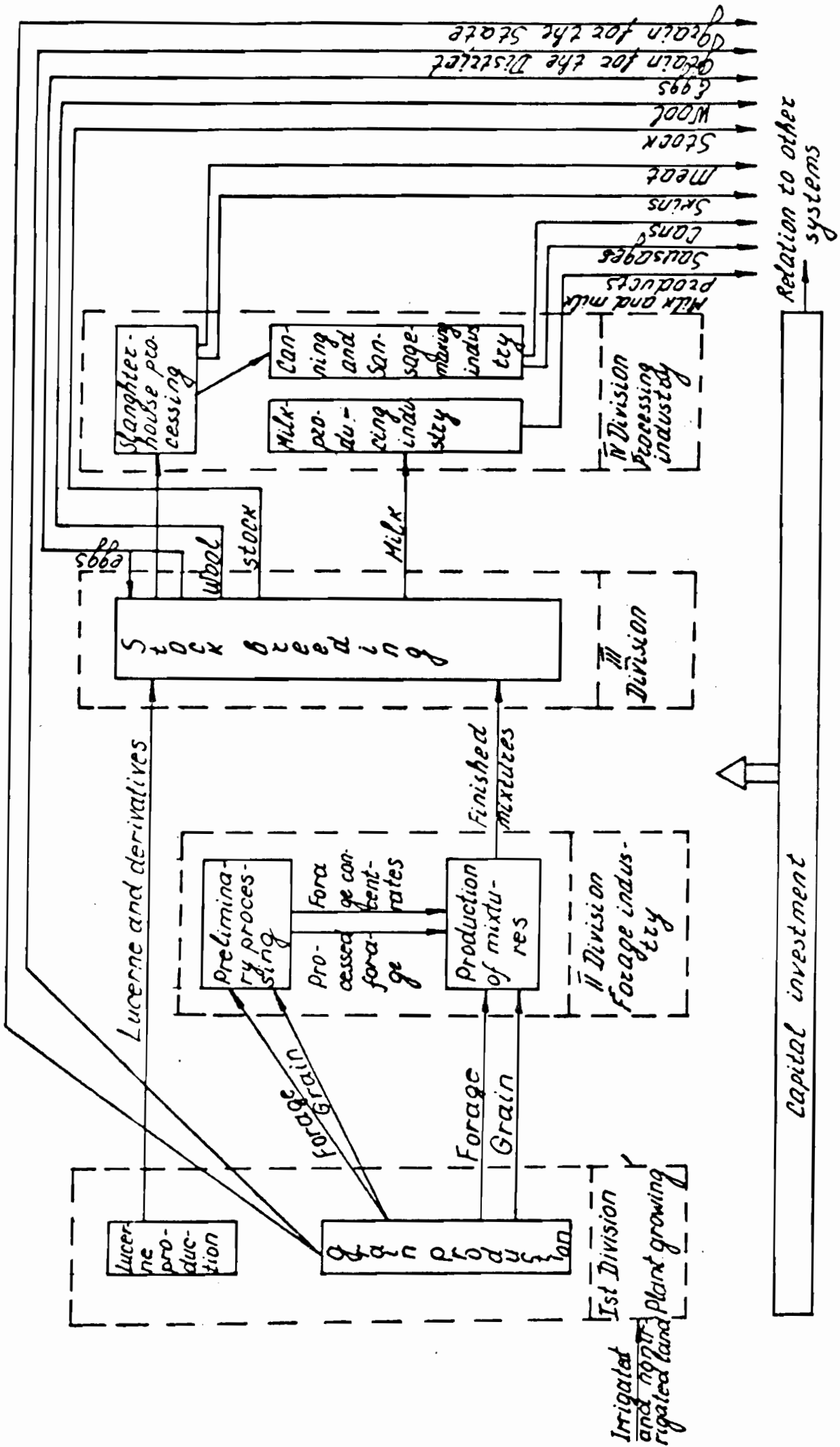

Figure 1. Divisions of "Drastar" and relationships.

of this project, it must be pointed out that it was directed mostly at stock breeding.

After estimating the shortcomings of such an approach, a research group from the Institute for Social Management was entrusted with choosing the optimal production structure of the complex to maximize net income. Because of the complexity of the task, mathematical modeling had to be applied.

After preliminary discussions of the developed statistical model of the "ideal" state of the complex and the methods for its achievement, the idea arose, in cooperation with the Food and Agriculture Program at IIASA, to develop a dynamic linear optimization model. An approach was adopted synthesizing formalized procedures in a mathematical model and expert procedures with participation of scientists, technologists, and managers.

After discussing more than 60 variants of the model, some of them were chosen and became the basis of the modeling of the development of the agro-industrial complex "Drastar".

Because of the presence of an already existing model (or a system of models and programs) for the development of agriculture of the Silistra region, the present study gives only a brief mathematical description of the basic dynamic model. It mainly contains problems created by the necessity to integrate this model with other ones. An attempt at such an integration has already been accomplished in the case of the model of water resources planning /5/.

More details about the results of that study may be found in /4/.

#### MODEL DESCRIPTION OF THE AGRO-INDUSTRIAL COMPLEX DEVELOPMENT

The main dynamic linear model simulates development for fifteen one-year periods. It consists of several connected blocks, reflecting development of crop production, stock breeding, industrial power and economic characteristics.



The initial basis of complex development is plant-growing. It originates from the desire to develop stock breeding and the green crop needed for feed so that only a minimum of components for animal food needs to be bought.

A great variety of crops are grown in the complex. They differ in nature and in technology applied for their growing; for example, agricultural technique, technological processes, type of land used, degree of irrigation, etc.

Let

$x^1(t)$  and  $x^2(t)$  with components

$$x^1(t) = \{x_1^1(t), \dots, x_i^1(t), \dots, x_n^1(t)\}$$

$$x^2(t) = \{x_1^2(t), \dots, x_i^2(t), \dots, x_n^2(t)\}$$

be the vectors of irrigated and nonirrigated crops, respectively, and

$$x(t) = \begin{bmatrix} x^1(t) \\ x^2(t) \end{bmatrix}$$

the vector of all crops.

Then, if  $X(t)$  is the quantity of cultivated land per years, the basic relation of land use is

$$\sum_{i=1}^n x_i^1(t) + \sum_{i=1}^n x_i^2(t) = X(t) \quad (1)$$

with the constraints:

$$x^1(t) \geq 0 \quad ; \quad x^2(t) \geq 0 \quad , \quad (2)$$

and

$$\sum_{i=1}^n x'(t) \leq x^1(t) \quad , \quad (3)$$

where

$x^1(t)$  is the quantity of irrigated land in year  $t$ .

Breeding of 4 kinds of animals is planned ( $Y_j(t); j=1,2,\dots,6$ ). These are: cattle (beef cattle and milk cattle), sheep (for meat and milk), pigs and poultry. Animals are also differentiated into categories, according to the specific technologies for the breeding of the separate age groups. Animals are thus characterized according to their function.

If

$$y_j^k(t) = \{y_{ij}^k(t), \dots, y_{ij}^k(t), \dots, y_{mj}^k(t)\}$$

is a vector of the number of animals from type  $j$  and group  $\kappa$ , and  $A_{(k)} = \{a_{ij}(\kappa)\}$  is the animals' transition matrix from group  $\kappa$  into group  $\kappa + 1$ ,

then

$$y_j^{k=1}(t) = A_{(k)} y_j^k(t) \quad . \quad (4)$$

If  $y(t)$  is the vector of animals from the various types and categories,  $B(t)$  - the animals' transition matrix from group into group, and from year to year and  $u(t)$  - the vector of the bought animals, a dynamic equation may be written as [see reference 6]:

$$y(t+1) = B(t)y(t) + u(t) \quad ; \quad (t = 0, 1, 2, \dots, T-1) \quad . \quad (5)$$

The following constraints are also imposed:

$$y(0) = y^0 \quad , \quad (6)$$

$$y(t) \geq 0 \quad , \quad u(t) \geq 0 \quad . \quad (7)$$

An upper constraint on the solution is also used:

$$u(t) \leq R^t \quad , \quad (8)$$

where  $R^t$  are the maximal numbers of animals in year  $t$ .

If  $C(t) = \{C_{ei}(t)\}$  is the matrix whose elements reflect the quantity of green crop of the type  $l$  from one unit of the crop  $i$ , then  $C(t)X(t)$  is the vector of obtained green crops.

Analogously, if  $D = \{d_{qj}^k\}$  is a matrix with elements reflecting the consumption of green crops of the type  $q$  by an animal of the type  $j$  in group  $k$ , then  $Dy(t)$  is the vector of food consumed by the animals during the year  $t$ .

$v(t) = \{v_l(t)\}$  is a vector of nutrients supply.  $w^1(t)$  and  $w^2(t)$  are vectors of purchases and sales of plant production.  $p(t)$  is a vector of consumption by the population of the region. It is now possible to formulate the balance equation:

$$C(t)x(t) - D_y(t) + v(t) - v(t+1) + w^1(t) - p(t) = 0 \quad , \quad (9)$$

with the constraints:

$$v(t) \geq 0 \quad , \quad w^1(t) \geq 0 \quad , \quad w^2(t) \geq 0 \quad (10)$$

and

$$v(t) \leq \bar{v} \quad , \quad p(t) = \bar{p}(t) \quad . \quad (11)$$

$\bar{v}$  and  $\bar{p}$  are set according to exogenous studies.

Let  $F = \{f_{qj}\}$  be a technological matrix, connected with animal production, and let  $z(t) = z_q$  be a vector of final products obtained from stock breeding. Then:

$$z(t) = F_Y(t) \quad (12)$$

and

$$z(t) \geq 0 \quad (13)$$

The "Drastar" complex needs production capital such as agricultural machines, buildings, machines and equipment for stock breeding, manufacturing works for green crops, meat and milk processing industry, store capacities, etc.

Then, if  $G = \{g_{\ell j}\}$  is a matrix with elements reflecting the necessity of machines for the respective crops, and  $g(t) = \{g_{\ell}(t)\}$  is a vector of the machines for land cultivation, then

$$g(t) = Gx(t) \quad (14)$$

When constructing the matrix  $G$  in (14), the most intensely planted periods for the respective crops were chosen.

Let  $H = \{h_{qj}\}$  reflect the use of buildings, machines and equipment for stock breeding, and let  $h(t) = \{h_q\}$  be the vector whose elements are the respective capacities. Then

$$Hy(t) - h(t) \leq 0 \quad (15)$$

Analogously, if  $S = \{s_{m\ell}\}$  is a matrix whose elements are technological rates of animal production processing and  $s(t)$  is the vector of manufacturing capacities, then

$$Sz(t) = s(t) \leq 0 \quad (16)$$

If  $r(t) = \{r_\ell(t)\}$  is the vector of store capacities, then

$$v(t) - r(t) \leq 0 \quad . \quad (17)$$

The following constraints are valid for the relations (14) - (17).

$$g(t) \geq 0 \quad , \quad h(t) \geq 0 \quad , \quad s(t) \geq 0 \quad , \quad r(t) \geq 0 \quad . \quad (18)$$

$\alpha(t) = \{\alpha_\ell(t)\}$  is a vector of expenditures (material, labor) in agriculture.  $\beta(t) = \{\beta_q(t)\}$  is a vector of expenditures in stock breeding.  $r(t) = \{r_q(t)\}$  is a vector of expenditures.  $\delta(t) = \{\delta_\ell(t)\}$  - is a vector of income from plant production sale and  $\varepsilon(t)$  is a vector of income from animal production.

The net income of the complex will then be determined as:

$$J(t) = \delta(t)w^2(t) + \varepsilon(t)t(t) - \alpha(t)x(t) - \beta(t)y(t) - r(t)z(t) \quad . \quad (19)$$

$\theta(t) = \{\theta_\ell(t)\}$  is a vector of purchase prices of agricultural machines.  $\rho(t) = \{\rho_q(t)\}$  is a vector with elements reflecting the value of one animal stall unit for animals of the respective type and function.  $\tau(t) = \{\tau_m(t)\}$  is the value of a unit capacity in manufacturing.  $\phi(t) = \{\phi_\ell(t)\}$  is a vector of the value of one unit storage capacity. The equation of financing can then be formulated as:

$$\begin{aligned} \theta(t)g(t) + \phi(t)h(t) + \tau(t)s(t) + \phi(t)v(t) + \Delta(t) \\ - M(t-1) - N(t) - a^J J(t-1) = 0 \quad . \end{aligned} \quad (20)$$

where:

$M(t)$  = allowances for depreciation during the period  $t$ ;

$N(t)$  = necessary credits;

$\Delta(t)$  = credit payment;

$a^j$  = coefficient showing what part of the net income of the complex may be used for development.

For this formulation of the problem, the criterion of decision quality can be formulated as:

$$\text{Maximize: } J = \sum_{t=0}^T \frac{1}{(1-v)^t} J(t) .$$

DESCRIPTION OF THE MODEL INPUT AND OUTPUT

*Input*

The input data may be conventionally divided into four groups:

- a) Data connected with the initial state of the complex and including all technical, technological, and economic parameters of the annual report for 1977 and the plan for 1978. Here are included the estimations of available stalls, machines, and equipment as well as the estimations of the possibilities for reconstruction and/or modernization of certain stalls.
- b) Data about grain and grain crop production; including
  - cultivated land by years;
  - the yield of main and supplementary production from various crops grown on irrigated and non-irrigated lands with different technologies, about fertilizers, seeds, preparations for plant protection, water, requirements of main types of machines, qualified and non-qualified manpower, labor and material expenses, etc., until 1985 and after 1985;
  - the biological interaction between separate crops and crop rotation;
  - the prices of the various kinds of grain, groats and the biological and mineral components of animal food;
  - capacity and cost of grain and crop storage, etc.;
  - others.
- c) Data about stock breeding (fertility, output, refuse, fecundity, milk capacity, laying capacity, etc.); dynamics of flocks; nutrition receipts and rules for the substitution of nutriment components; necessary quantities of food of definite type for one animal

of a given type and/or function, breed, and category; terms of using and cost of one stall of a given type; labor intensity and production expenses for inputs and prices of animal production.

- d) Data about the development of irrigated lands, the natural and economic parameters in grape-growing, vegetable production, and about regional requirements for food and animal production, etc.

#### *Endogenous Decision Variables*

The standard decision variables of the linear problem are the following:

- irrigated and nonirrigated lands with selected crops cultivated with one or another technology;
- number of animals of a definite type, breed and age, bred with one or another technology (including the number of animals bought;
- number of newly built stalls of a certain kind;
- number of newly bought machines of a certain kind;
- estimations of working time efficiency of machines;
- quantity of reserves, purchases and sales of different kinds of grain;
- economic characteristics--labor and material expenses, expenses for building-installation activities, for the purchase of new animals, machines and equipment, allowances for depreciation, credits, total production, net income, etc.

#### SOURCES OF INFORMATION

The following may be said about use of data and information supply:

The initial stage in model construction is assignment of objectives, scope and character of research activities. Though there have been corrections and additions to the assignment,



the basic conception has been preserved to the end: "A project for an agro-industrial complex should be developed, applying the latest achievements of world and Bulgarian science, using completely the available resources, possessing an efficient export and a high degree of specialization in the field of plant growing and stock breeding." It was accepted that all substantial-energetic resources entering the complex as feeding resources or leaving it as final products should be evaluated at international prices (including raw materials and intermediate goods produced in Bulgaria and products for internal consumption).

Because of the impossibility of including peculiarities of various climatic and soil regions, technologies for the separate crops differ in the following parameters:

- a) type of crop;
- b) type of soil--with and without irrigation;
- c) type of agricultural technique applied.

Parameters connected with soil and climatic characteristics have been averaged.

The separate crop technologies have been developed by specialized scientific institutions. They have been subject to numerous discussions, and during the process of the model development and its functioning, a series of technologic and economic parameters were further specified and corrected. More than 300 technologies for plant-growing are included in the model and for the separate crops from 4 to 30 different technologies compete.

All technologies are worked out in two variants, containing parameters, which must be reached in 1980 and 1985, respectively.

Due to the fact that 30% of the terrain in the region is hilly, all technologies were accordingly adjusted. Chain machines were obligatorily introduced, which brought about corrections in labor and material expenses (except for beans, which will be grown 90% on flat terrain and only 10% on hilly

terrain). It was additionally accepted that 50% of the maize for grain will be collected as seeds and 50% as cobs.

The technologies for the separate types of stock breeding were also worked out by specialized scientific institutions. Due to the fact that up to now no such complex project has been developed and that there exist substantial differences between the separate technologies, there was no representation of technologies available. Some aggregate natural and economic parameters were an exception and for them a unified form of representation has been developed. In order to avoid an excessive expansion of the model, certain types of animals are not treated separately but in aggregate form. For every separate kind of animal we propose a module unit of breeding, including all necessary equipment, service buildings, grounds, etc., but without purification equipment.

Technologies for grain-crop production and for grain-crop manufacturing include description of production processes, necessary raw materials and their quantities, semi-manufactured goods and materials and their quantities as well as economic characteristics of final output. These technologies may be divided into four main groups: (a) for manufacturing concentrated grain crops and obtaining concentrate and bio-concentrate mixtures; (b) for manufacturing raw grain crops; (c) for grinding alfalfa into flour; (d) for obtaining silage and hay. The first three have an industrial character and require specialized technologies, while the last one concerns only the silage pits and here the standard agricultural technique is applied.

Data from the presented model with its technological representation are used to determine manufacture of animal products. The presented figures are indicative only. Variants for packing houses equipped with various machines, and dairies of different capacity and structure of final product are presented. There are available no projects and technologies for processing of wool and fur, and these are therefore evaluated as raw products.

No poultry project is presented because the neighbouring districts dispose of sufficient vacant capacities.

Information about some servicing and accompanying activities is also needed. This is the case, for example, for agrochemical service, control of hail damage and erosion, and water and air purification. Those activities do not result in direct production, but their application requires additional capital deposits and production expenses. It is thus necessary to represent them in economic parameters that can clarify the financial and management problems of the complex. These variables, however, have not been formally introduced in the model.

For the determination of the dimensions of nonirrigated lands by years, the plan for the construction of irrigation systems in the Silistra region till 1990 was used. According to that plan, the total area of irrigated land in the region must reach 1 100 dka in 1989. The specialists in water supply and development have participated in the determination of the technological and economic parameters of crop growing under irrigation.

Since the object of modeling is only the development of grain production and stock breeding in the complex, the information about the development of vegetable growing and permanent crops is taken from a special project. The land used for those activities is deducted from the total land balance, and the development of those fields is not modeled.

From the analysis of the variants obtained from the model, it became clear that a series of them does not correspond to the requirements of certain political, social, and economic criteria. That brings about the necessity to seek the assistance of higher level planning experts who can determine lower and upper limits on the development of certain products. Such constraints have been used for pig breeding (top limit), for sheep breeding, for the purchase of some raw materials, and for animal imports from abroad.

Data on the development of the complex until the beginning of the model may be divided into four groups:

- a) initial data: those are data about available animals (according to the plan) till 31.XII.1978, agricultural machines, available irrigated lands, perennial crops (for example, alfalfa), and others;
- b) characteristics of certain technologies (mainly in stock breeding), which will be used in the complex and which are supposed to exist in future as well;
- c) available and estimated future basic funds;
- d) financial obligations, payment of which will be made in the period of the project.

Forecasts of world market possibilities have a preliminary character and have been worked out by specialized external-trade organizations. They refer to the possibilities of machine import, equipment, stock breeding, deficit raw materials, materials and energy import, and to the possibilities for exports of final products.

Several forecasts about prices of agricultural products at the international market have been made for the period until 1990. All production exported by the complex, and all purchased machines, equipment, animals, and raw materials in the model are evaluated according to these international prices.

#### PROBLEMS OF INFORMATION SUPPLY

A lot of problems are connected with the determination of coefficients, due to their large number as well as the variety of information sources.

*A Unified Metric System*

The first and main task consists in working out a unified metric system, which can simplify comparison of various coefficients and parameters.

*A Unified System of Parameters*

In economic practice a great variety of cardinal value parameters is used. The same refers to development of technologies for the various products. In separate technologies, or groups of technologies, incommensurate parameters are often used. The inclusion of such parameters in the models is impossible because it will bring about important computing difficulties. In order to avoid these problems a unified system of parameters was developed which has made possible direct comparison between separate technologies.

The system embraces the following main groups of indices:

- a) Productivity per unit of a typical representative of a given manufacture.
- b) Production expenses in value (labor and material) per unit of input.
- c) Necessary capital per unit of animal or machine.
- d) Resource expenditure, by types and products, per unit of land or animals.

All parameters in this system refer to one period (period in the sense of the model).

*Definition of Some Economic Parameters*

In order to obtain a more distinct picture of the real economic achievements of the complex and in order to eliminate the influence of certain imperfections in the prices, etc., the evaluation is accomplished according to planned normative prime costs of production. In order to estimate the efficiency of various technologies in stock breeding, it is assumed that the whole grain-crop quantity necessary for animal

nutrition is obtained from irrigated lands. Thus, parameters may be obtained, as for example:

- area necessary for feeding of one animal;
- expenses connected with breeding of one animal;
- profitability of stock breeding production as compared with crop-growing production;
- quantity of meat per decare;
- total value of production of stock breeding and agriculture;
- net income per decare from stock breeding and agriculture, etc.

*Problems of Machine Model Information Supply*

The data for such a large model produces a series of difficulties. The greatest problem concerns elimination of mechanical mistakes when data are transferred to tapes, discs, etc. The large number of columns and rows also makes it difficult to detect mistakes. The following is done in order to avoid mistakes:

- a) A suitable system for indexing of rows and columns in the model is chosen. This indexing simplifies the interpretation of the model. For example, all rows and columns referring to a definite period have one and the same last figure. The most important variables have a mnemonic record.
- b) Where possible, programs for automatic generation of the matrix coefficients are used.
- c) Explanations of the sense and contents of separate rows and variables are included.

## ADDITIONAL PROGRAM SUPPLY

In order to eliminate some of the above-mentioned problems and to facilitate the work of the researchers using the model, a package of additional programs is created, which handle the model input, its running and the processing of final results.

### *Data Supply and Updating It*

As was already mentioned, significant difficulties are encountered in generation and renewal. For the elimination of those difficulties, a special package of programs has been worked out, allowing automated generation of coefficients in a format suitable for the standard programs. This brings about a significant facilitation of technical operation and reduces the possibility of technical mistakes.

### *Model Running*

For the purpose of the facilitation the running process and the preservation of the matrix and the obtained results from unauthorized access and breakage, a complex of special matrices is built, providing the fulfillment of the following functions:

- a) matrix renewal--all necessary information is preliminarily recorded in the machine operation system on a disc. The files remain in safe-keeping under the operation system control.
- b) recording of matrix on a magnetic tape. Thus, three generations of the matrix are stored for possible use if the basic magnetic disc is damaged.
- c) recording of the obtained decision in a file (simulated map file) to be used by other programs. It is done by the operation system;
- d) making a security copy of the matrix from one disc onto another disc.

*Programs for Processing the Obtained Results*

The processing of the results obtained from the machine in a form suitable is accomplished by a specially designed package of programs. The programs are written in FORTRAN IV and use for their input the optimal decision parameters of the linear problem, normatives for the obtaining of derivative parameters (for example, expense norms, productivity, proportions, nonlinearity, lags, prices, etc., are not reflected in the model) and preliminarily set texts. By means of this package, the following problems are solved:

- a) disaggregation of the parameters by two-year periods for the constituent one-year periods. By means of suitable subprograms, the best approximating curve of the development is chosen, corresponding to the dynamics of the relevant parameter;
- b) by means of the inserted additional relations all tributary parameters, which are not computed by the basic model, are determined. Thus from 1041 variables (in the model), more than 3500 parameters are computed;
- c) possibilities are created for making additional corrections in the decision, obtained by the model;
- d) all parameters are printed in tables, convenient for using by a wide circle of specialists.

The package gives the following output information:

- irrigated lands and total areas with definite types of crops;
- aggregated data about area distribution--areas, covered by grain crops, joint and earthed-up crops, second crops, total irrigated and nonirrigated areas, etc.;
- grain production and additional products from tillage;
- the number of different types of animals;
- the production of various kinds of meat;



- additional animal production--milk, wool, eggs and furs;
- the number of people in the separate fields of stock breeding;
- available and newly built stalls of various types;
- available and newly bought machines of different kinds;
- the incomes from sales of various types of pure meat and by-products;
- labor intensity in grain and other production per months;
- labor and material expenditures in grain production and in stock breeding;
- economic characteristics--labor and material expenses, capital deposits, basic funds, currency expenses, total production, net production, net income, various estimations of economic efficiency, etc.

POSSIBILITIES FOR EXPANDING AND IMPROVEMENT OF THE LINEAR DYNAMIC MODEL AND ITS ADDITIONAL PROGRAM SUPPLY

*Specifications and Details of the Existing Correlations*

A part of the arable land is gradually adopted for road construction, irrigation equipment construction, farm grounds, etc., as well as for field-protecting belts. Thus the total arable land is constantly decreasing.

In grain production, the transition from the existing to the modern technologies is accomplished step by step. The method of realization of this transition is an object of annual update.

The observed "main types of agricultural machines" may be specified according to types, trademarks, and models. This will bring about details of the information about the prices, manufacturing possibilities, terms of fitness, expenses for repairs and maintenance, necessary labor resources, etc. As a result, the work load of the machinery will be further surveyed

as well as the possibilities for interchanges, etc.

If the biological and mineral components in animal food and fertilizers used in grain production and perennial crops are considered as natural parameters, important information will be obtained about the activities of supplying services.

If the model considers what is additionally produced in private farms, corrections in the correlations reflecting satisfaction of regional necessities can be made.

By means of an annual actualization of the prices and the amounts of grain and stock breeding production, for which guaranteed markets exist, evolutions may be made within the framework of the accepted strategy for the development of the complex.

*Including New Correlations and Values*

It is only proper to reflect education and personnel displacement expenses, and to account for the relevant social and political effects.

With a view to the more complete utilization of land potentials, stock breeding technologies may be researched, utilizing to a higher extent raw grain crops, grain production waste, fruit- and vegetable-canning industry, mill- and meat-manufacturing industry, etc.

The review of construction and work of agrochemical centers and the consideration of expenses for services will help in the specification of the amount and structure of capital deposits and material expenses.

*Improvement of the Model Structure*

- External setting of the length of the studied period, time and transition from single and double to only single periods;
- simulation of nonfertility, droughts, and other natural disasters;
- study of the possibilities for the using of other types of grain crops and additional stock breeding;

- creation of a set of different purposeful functions, which may be of interest in various economic, technological or social analyses;
- creation of a relatively differentiated block for the study of manufacturing industry and its relations with stock breeding;
- considering the economic contacts of the agro-industrial complex with those from other regions.

POSSIBILITIES FOR DEVELOPMENT OF THE SYSTEM OF MODELS  
FOR AGRICULTURAL PRODUCTION DEVELOPMENT PLANNING AND  
ITS CONNECTION WITH OTHER MODELS OR SYSTEMS

The future of the developed system of models, based on the linear dynamic model of the development of the large agro-industrial complex, may be reviewed in two aspects:

*Automation of the Information-preparing Base of the Model*

It is essential to develop an information system, which will update the information for the model, after each correction of the technology maps or the stock breeding technology. That would simplify the analysis of the effect of separate technological coefficients and help to transfer the optimizing system into a simulation system. To this end, optimization models for the separate technological processes may be created, which will fulfill the information-preparing function. We could take a step back--to land potentials, and then look for the best technologies corresponding to the possibilities. But all that requires a detailed preliminary activity of specialists in agriculture and specialists in information-retrieval systems, in order to develop an automated information system storing and processing all the necessary normative information. In our opinion, that approach allows a more complete automation of the process of project development, beginning from the land and terminating with a production program for a given territory or production unit.

*Connections Between the Models in the System of Models*

There is a connection between the developed system of models and models or systems of models treating the remaining problems of the development of a territorial unit or a region. Such models may consider problems connected with settlement systems, transport, engineering network and equipment, etc. In our opinion, several basic groups of problems must be solved:

- The communication between the separate models on information level requires the development of suitable parameters of transition from one model to another one and the way of transfer. It is not necessary to do that in an "ON LINE" mode in the machine, but it is preferable to accomplish it on the level technic bearer (magnetic tape, magnetic disc).
- The technological connection of the models presents problems not only to the technique of modeling, but to the modeling of the process as a whole. It is necessary to specify clearly the inputs and the outputs, connecting the separate models and the consequence of the connections. The graph of the connection will not be open, but it will have separate cycles, i.e., as iterative decision will be required.

The additional model must be constructed by connecting the base linear dynamic model with a series of assisting models of a certain process or phenomenon in agriculture; for instance:

- Model for ration optimization;
- Model for optimization of the machine and tractor park;
- Model for supply and reserve management;
- Routing models, etc.

All those models may serve for the postoptimization of the obtained decisions, or be used for the automation of the information-preparatory activities.

That is the idea of the future connection of the base model with the model for the territorial location of production capacities.

- The boldest ideas are connected with the further development of the system of models with a view to embracing the whole planning cycle. By applying the system for report information processing, the chain may be closed (Figure 2).

After that, or parallel with it, an attempt can be made for quasi-expansion of the base model by expanding and further developing the existing system of preliminary assumptions, and creating a representative set of modeling blocks and a macro-language for them. Thus, every agro-industrial complex will give in to modeling by the assembling of a proper combination of those blocks and the adjustment of certain parameters and connections.

Finally, the possibility may be considered for the inclusion of the developed system of models in a hierarchical system of models for planning the development of agriculture within the country.

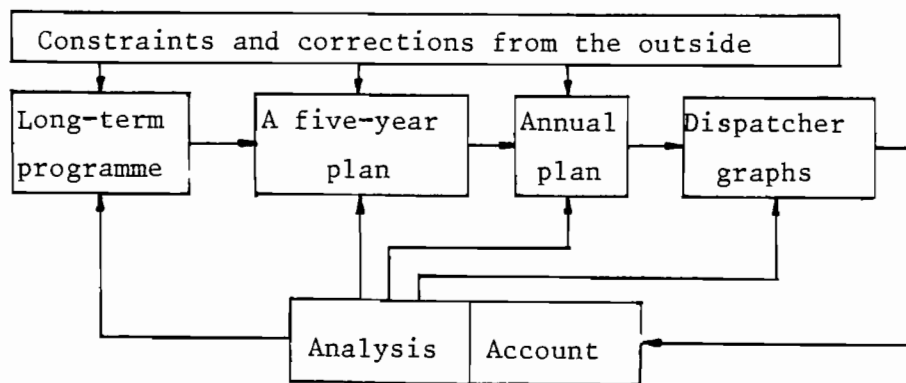

Figure 2. The planning cycle.

REFERENCES

- Carter, H.O., C. Czaki, and A. Propoi (1977) Planning long-range agricultural investment projects; a dynamic linear programming approach. RM-79-00. Laxenburg, Austria: International Institute for Applied Systems Analysis. Forthcoming.
- Czaki, O. Dynamic linear programming model for agricultural investment and resources utilization policies.
- Gavrilov, G., H. Milenkov, and A. Kehayov. A dynamic linear model of the development of a large agro-industrial complex. "Nauchni trudove ISU", 4/1977, Sofia.
- Gavrilov, G., S. Stoikov, H. Milenkov, and A. Kehayov (1979) Model of the development of a large agro-industrial complex. CP-79-00. Laxenburg, Austria: International Institute for Applied Systems Analysis.
- Gouevsky, I. et al. (1979) A system of models for water resources development in Silistra region. CP-79-00. Laxenburg, Austria: International Institute for Applied Systems Analysis.
- Propoi, A.I. (1976) Problems of dynamic linear programming. RM-76-78. Laxenburg, Austria: International Institute for Applied Systems Analysis.
- Stoikov, S. (1974) Linear dynamic models for optimization the structure and territorial distribution of industry. Planning in agriculture organizations and works. Zemizdat: Sofia.
- Swart, W., C. Smith, and T. Halderby (1975) Expansion planning for a large dairy farm. North Holland: Elsevier, NY.

A SYSTEM OF MODELS FOR WATER  
RESOURCES DEVELOPMENT

I. Gouevsky, S. Stoykov, V. Genkov,  
A. Stanoulova and B. Topolsky

Water resources have played an important role in most of the regional development programs due to the substantial impact of these resources on technological, political, economic, social, and environmental processes in the respective regions. The Silistra development program--launched several months ago--will not be an exception in this respect because of the vital importance of water for the region. The intensive agricultural and regional development in the next years calls for withdrawal of considerable amounts of water which is generally rather scarce in the region. Water is available in the region through the following three sources.

- Danube river which borders the region. No other rivers--which could augment water supply in the irrigation season--exist in the area;
- Groundwater is available only in small quantities or at depths exceeding 400 m, which makes it an unimportant resource as far as crop irrigation is concerned. This source is mainly used for potable water supply in areas closed to the Danube terrace;
- Precipitation (rainfall, snowfall) is insufficient over the irrigation season (May-September) even in a wet year as is shown in Figure 1.

This Figure illustrates the region's average rainfall and

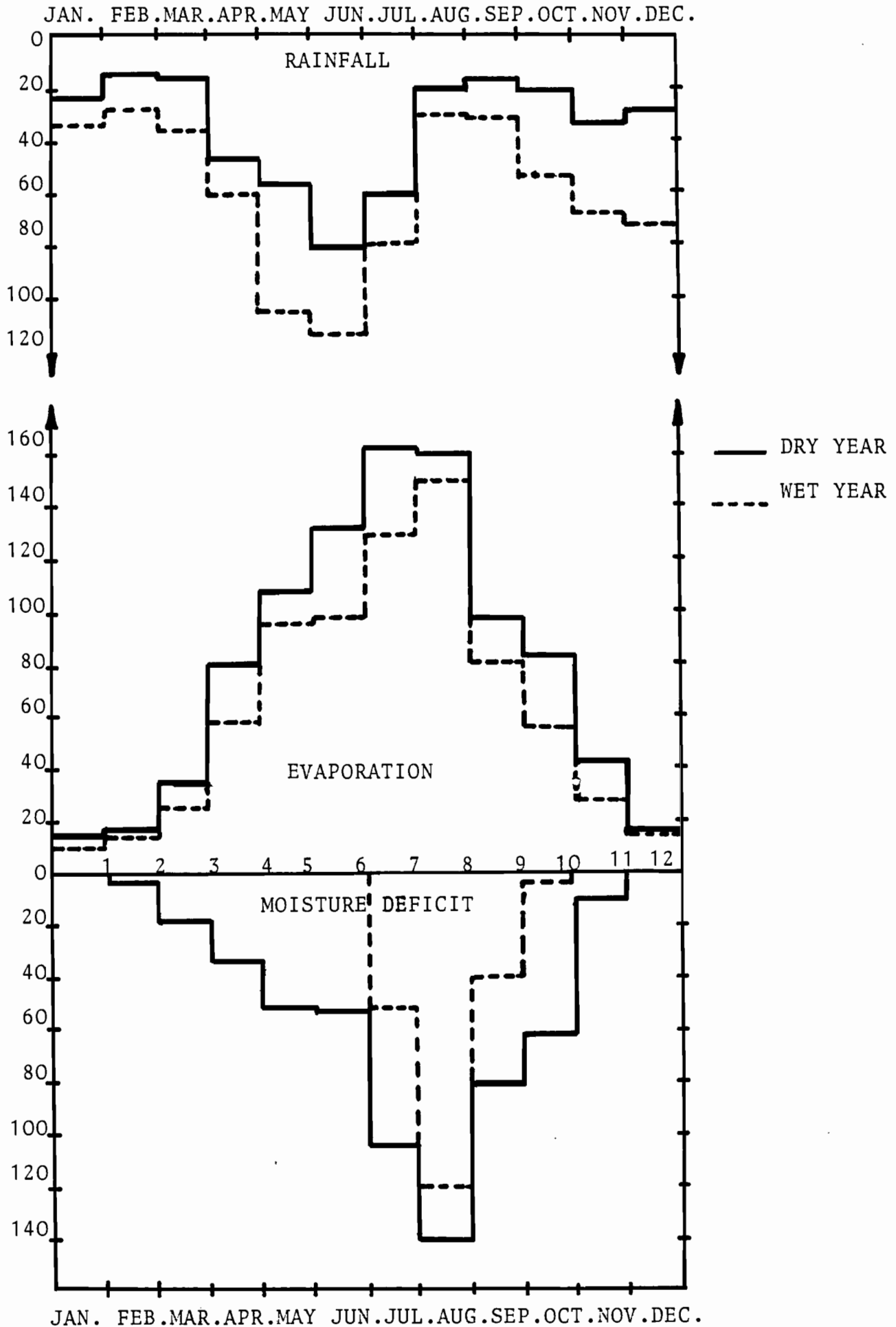

Figure 1. Rainfall, evaporation and moisture deficit in representative years (1 out of 4 years is dry and 3 are wet).



evaporation distributed over time in both dry and wet years. In a dry year the moisture deficit is throughout the irrigation season, while in a wet year it is only for June, July, August and September. Hence, to ensure stable agricultural production, a large reliable water supply has to be made available in the region.

Any water resources development that takes place under these conditions should be preceded by a thorough analysis of a number of economic, technological and environmental problems. This analysis is intended to assist with:

- evaluating the impact of water resources on the overall regional development as well as on the other regional resources (labor, machinery, fertilizers, etc.);
- estimating irrigation and livestock water demands and their distribution in space and time within a given year; forecasting of these demands for some years ahead;
- determining the optimal proportion of the arable land within the region that should be developed for irrigation;
- evaluating the impact of water pricing policies in the region on quantity of water demanded (demand function for water)
- determining the type of irrigation equipment in the region, taking into account economic, technological, topographical and labor conditions,
- determining the least-cost system of facilities (reservoirs, pumping stations, irrigation canals) to meet the projected water demands.

The Silistra water resources have been under development for many years. A few scientific and development organizations have been engaged from the very beginning. A leading role among them has been played by "Vodproject" who's main concern is designing of reservoirs and irrigation systems. A detailed geographical, geological and economic study has been carried out and a number of alternatives for augmenting the water supply have been proposed. In 1977 the IIASA Water Demand group carried out a water demand analysis (see Gouevsky,

Maidment, 1977, Gouevsky, Maidment, Sikorski, 1978) of irrigation and livestock potable water demands in the Silistra region. The model is being further extended and refined in Bulgaria by the authors of this paper in close cooperation with the Institute for Engineering Cybernetics at the Bulgarian Academy of Sciences and the Ministry of Agriculture and Food Industry. In 1978 the IIASA Regional Development Task initiated a case study to evaluate water supply alternatives for one of the irrigation system in the region. The preliminary results were presented in Jablonna, Poland (Albegov, Chernyatin, 1978).

The aim of this paper is to outline the general methodology for developing water resources models and linking them with other regional models of (agriculture, industry, human settlements and services) in Silistra region.

#### WATER USE IN THE SILISTRA REGION

Water is being used now and will be widely used in the future mainly in the following activities:

- agriculture (crop and livestock production and processing)
- potable water supply (population and livestock)
- industry
- transportation (and other in-stream uses)
- recreation (and other on-site uses)

Agriculture is assumed to be the largest water user in the region due to the vast irrigation development to meet the feed requirements of meat- and milk-producing livestock.

Potable water supply for people and livestock is the second important use. This supply requires transfers of water approximately 60-80 km from the water source. Substantial capital investments are required to provide this supply.

Industry is the next important water user. Two types of enterprises exist: heavy water users (food and kindred

products, wood-processing) and other users (machine building, services). The residuals generated from the industry may also cause some up-stream - down-stream conflicts in the future.

Water use for transportation and recreation is limited for the time being to areas located near the Danube. The development of the region however calls for providing the opportunity for people living in the central and southern part of the region to have access to these services. In this respect there may be conflicts in the future between agriculture and these two water users. To avoid such conflicts a comprehensive analysis of user demands should be carried out.

#### GENERAL STRUCTURE OF WATER RESOURCES DEVELOPMENT MODELS

Water resources development in the Silistra region is carried out in the regional economic, social and environmental policies, needs, and technologies. Important factors influencing overall development of the region are: scarcity of water, high cost of providing water to various localities, large water demands in agricultural activities that are spread all over the region; existence of other important users (potable water supply, industry) whose water demands must be met by guaranteed water supply. All this requires that both water demand and supply alternatives have to be thoroughly examined to reveal the most preferable water resource development alternatives from the economic, social and environmental point of view. In doing so, two approaches can be implemented: extensive and intensive water resources development. The former is characterized by a progressive increase in the amount of water supplied when the demand rises. In contrast, the objective of the demand-oriented intensive approach is to make the most efficient use of the existing water supply. These two approaches can be combined to yield a system of water resources development models as shown in Figure 2.

This scheme indicates that in modeling water demands the respective activities can be decomposed into five separate models. The supply system however is the same for all users.

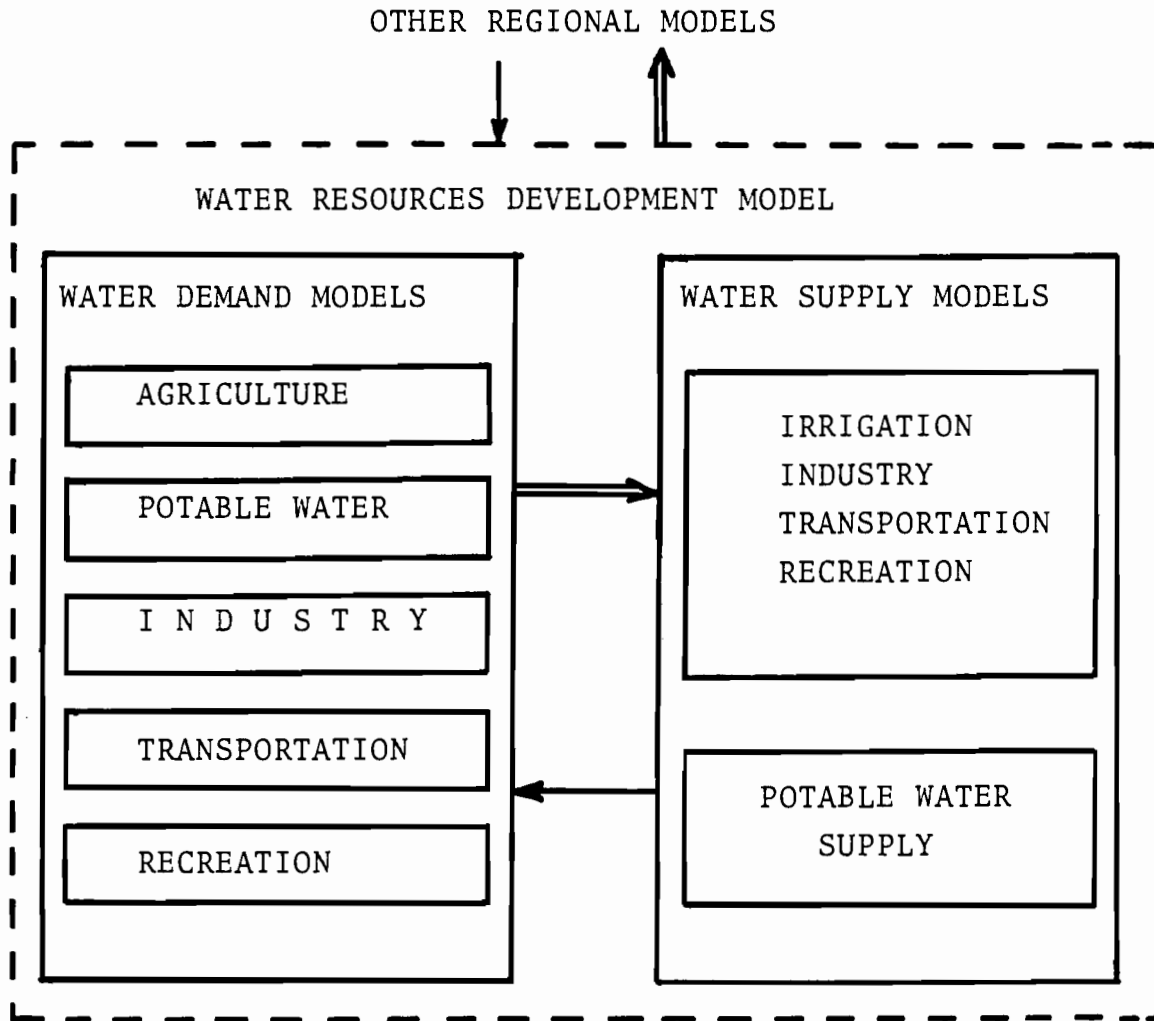

Figure 2. A System of water resources development models.

except for potable water supply.

The possibility for decomposition of water demand models is a great advantage in the modeling process. Having decomposed the models one can obtain a deeper insight into the respective activities, their relationship with other regional models as well as their particular impact on water supply.

The following discussion is mainly devoted to deriving the demands of the largest and the most significant water user --agriculture--as well as to the interactions of this model with the supply model and other regional models.

#### AGRICULTURAL WATER DEMAND MODEL

There are about 1,500 km<sup>2</sup> (150,000 hectares) of arable land in the Silistra region on which crops are grown to feed the livestock to meet the needs of local population, and to generate export of crop production. The aggregated agricultural production process is shown in Figure 3. There are seven subsystems: input resources, irrigated and nonirrigated crop production, crop processing, livestock production, livestock processing, marketing (import and export of crop and livestock products, domestic consumption), and environment.

#### *Objectives of the system*

The decision makers in the Silistra region have a number of objectives in mind for the development of agricultural activities. These include having:

- Maximum production so as to meet the needs of the Silistra population for food and other agricultural export from the region.
- Efficient production, i.e. minimum cost per unit of output. This implies that the flows of material between the various processes in Figure 3 are in harmony with one another and that the least-cost alternatives of inputs is used. It also involves an emphasis on using the most advanced technologies in crop and livestock production.

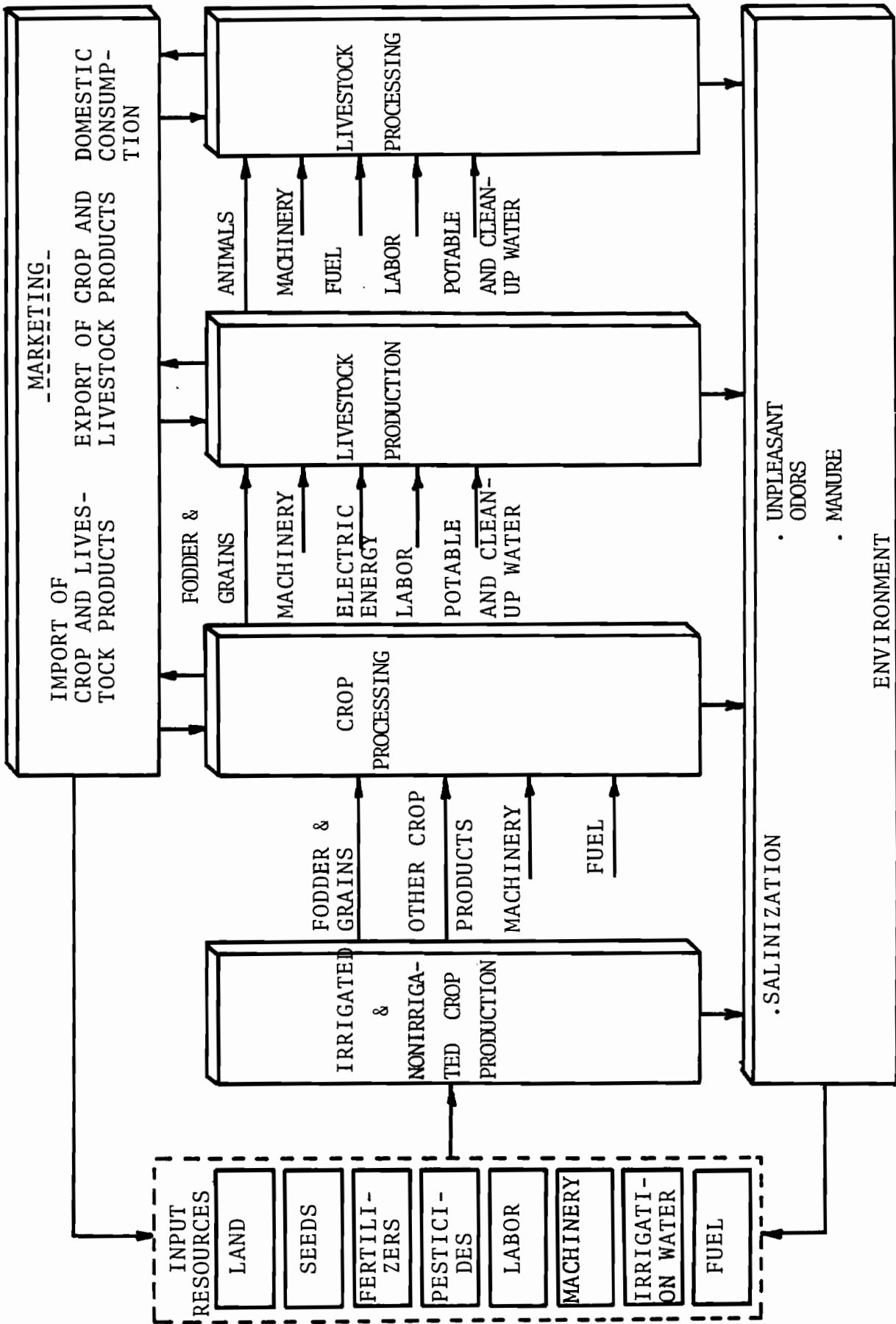

Figure 3. Aggregated agricultural production process in the Siliistra region.

- Sustainable production. Over the short-term this involves minimizing the impact of weather variations by providing irrigation, and producing reserves. Over the long-term soil fertility must be maintained through proper cultivation and crop rotation. There are also risks from diseases or market uncertainties if one tupe of animal is allowed to dominate over all others in the region.

*Brief Review of Water Demand Modeling  
Effort in the Silistra region*

Three agricultural water demand models have been developed since July, 1977: SWIM 1, SWIM 2, and SWIM 3 (Silistra Water for Irrigation Model) each of them incorporating in different ways the above stated objectives.

The first version, SWIM 1, was aimed at deriving agricultural water demands considering only crop production, processing, and marketing in the region as a whole. Grain crops were allowed to be exported or imported. Livestock was considered exogenously by specifying the required amount of grains and fodder to meet livestock feed demands. SWIM 1 is a small linear programming (LP) model with 56 constraints and 68 decision variables involving 400 data values. The model has been solved more than 50 times for the conditions of constrained irrigated land and constrained irrigation water for both a normal and dry year.

The second version, SWIM 2, was developed in September-November, 1977 after discussions of the results of SWIM 1 with agricultural and water experts in Silistra. The following basic modifications were introduced in SWIM 2:

- the region was divided into three subregions according to the three major irrigation systems to be built;
- livestock (cows, pigs, sheep, hens) and their feed requirements expressed in feed units and protein were introduced as endogenous variables;
- as far as crop production is concerned the region was modeled as a self-contained one, i.e. no import or export of grains and fodder were allowed;

- SWIM 2 computes the total required capital investments divided into two parts: irrigation investments, and machinery and buildings investments;
- two levels of fertilizer application were modeled: 100% of the amount needed to get optimal amount of yield, and 80% of this amount;
- crop rotation was explicitly introduced;
- water crop use coefficients ( $m^3/ha$ ) for all crops were calculated on the base of rainfall, temperature, wind speed, and cloudiness using the Penman method;
- water demands were calculated for 10-day intervals in the irrigation season and assumed irrigation efficiency;
- grain reserves were explicitly accounted for in the model;
- potable water demands for all animals were also explicitly computed;
- a feedback was introduced to allow for substitution of manure for fertilizers and vice verse;
- SWIM 2 internally determines the optimal level of irrigation land development and the corresponding water demands;
- the model was used to provide forecasting of water demands as well as to evaluate the impact of constraining resources (water, fertilizers, capital investments).

SWIM 2 has 152 constraints, 218 decision variables and 2020 data values.

In August 1978, a new version, SWIM 3, was begun by the authors of this paper. This version is a further refinement of SWIM 2, making it up-to-date with the newest conceptual developments for the region. SWIM 3 is also being designed to allow for close interaction with the other models, and in particular with the agricultural model developed by Gavrilov et al. (1978) and with the water supply model suggested by Albegov and Chernyatin (1978). The basic changes that are



introduced in SWIM 3--in comparison with SWIM 2--are as follows:

- further subdivision of the Silistra region has been made to allow for soil fertility, climatic and weather conditions, and different costs of the water supply. Thus, SWIM 3 has five subregions instead of the three in SWIM 2;
- cows, sheep and pigs have also been further subdivided into 20 categories distinguished by herd structure, animal age, and purpose (for meat, milk, wool)
- the requirement that Silistra is self-sufficient in grain and fodder production has been relaxed. SWIM 3 allows for some grains to be exported or imported;
- irrigation capital investments have been refined to take into account more recent figures obtained for the region;
- three types of irrigation techniques have been introduced to find the optimal mix among them;
- the two levels of fertilizer application have been abandoned;
- potable water for crop and livestock processing is explicitly taken into account;
- when SWIM 3 is used to forecast water demands over the planning horizon (1980-1990), the livestock numbers are exogenously introduced from the agricultural model (this is one of the basic connections between the two models);
- SWIM 3 accounts for constraints on labor over the cultivation season and its critical phases, i.e., irrigation and harvesting of various crops.

The driving force for the changes of the model has been the interaction process between the model builders and the Silistra decision makers. This process has involved identification and clarification of the objectives of the system, various ways of achieving the goals, different opinions about one or another development alternative. It is quite clear that this process will continue in the future and that the more models are introduced the more complicated the preference and decision structure will become.

*Basic Modeling Assumptions*

The previous section reveals some of the modelling assumptions for the three SWIM versions developed so far. There exist, however, some basic assumptions which have not been changed during the study. These include the following:

- to obtain the agricultural water demands the system is modeled for one year. Depending on the coefficients included in the model, this one year can represent the conditions of any specified year such as 1985, 1990, etc. Year-to-year variations are not included however, because of the intended interaction between the SWIM model and the agricultural model, which accounts for such variations;
- linear relationships are assumed to exist among the decision variables; nonlinear relationships are piece-wise linearized and the obtained segments are introduced as separate decision variables (e.g. crop yield vs. soil fertility);
- all costs, prices, and technological coefficients are known; economies of scale are not explicitly included. For example, in a given subregion, the cost per hectare of delivering irrigation water to the field does not depend on the number of hectares irrigated;
- the agricultural system is decomposed from other regional systems (industry, potable water supply, transportation, recreation) for the purpose of deriving irrigation water demands. The coordination among the models of these systems is achieved by running the respective models interactively;
- supply alternatives are not explicitly incorporated in the model. Instead, only the cost of supplying a given subregion is introduced. These supply costs serve as coordination parameters between the demand and supply models;
- the single criterion optimization approach is used, namely, maximization of the net benefit from agricultural production; if other objectives exist they are incorporated into the constraints;
- environmental considerations are limited only to modeling of the following factors: providing additional amounts of water to leach the salts in the soil; utilization of animal wastes.

*Mathematical Description*

The description that follows formalizes the relationships between the various subsystems in the agricultural system into an aggregate LP format. For ease of explanation, all activities (decision variables) and constraints in the model are aggregated into 15 decision vectors and 17 sets of constraints, as shown in Table 1. The objective function, OB, which has been adopted for the agricultural production in the region, maximizes the annual net benefits, i.e. the difference between the value of marketed livestock and crop products, and total production cost:

$$\begin{aligned}
 \text{maximize OB} = & \underbrace{b_4x_4 + b_5x_5 + b_6x_6 + b_7x_7 + b_{10}x_{10}}_{\text{crop and livestock production benefits}} \\
 & - \underbrace{c_1x_1}_{\text{crop production cost}} - \underbrace{c_2x_2 - c_3x_3}_{\text{crop processing cost}} \\
 & - \underbrace{c_9x_9}_{\text{livestock production cost}} \\
 & - \underbrace{c_{11}x_{11} - c_{12}x_{12}}_{\text{irrigation cost}} \\
 & - \underbrace{c_{13}x_{13} - c_{14}x_{14} - c_{15}x_{15}}_{\text{other inputs cost}}
 \end{aligned}$$

where

$x_i$  = a vector of aggregated activities (see Table 1 for details);

Table 1. Aggregated matrix structure of Agricultural water demand model

Decision vectors, $x_i$	Irrigated & nonirrigated crop areas	Fodder products	Grain products	Population crop products: grain, other	Grain reserves	Export of other crop products	Grain products for livestock	Grain products for livestock	Irrigation & drinking water demands	Irrigation equipment	Fertilizers	Machinery	Capital investments	RHS
Set of constraints	$x_1$	$x_2$	$x_3$	$x_4$	$x_5$	$x_6$	$x_7$	$x_8$	$x_{10}$	$x_{12}$	$x_{13}$	$x_{14}$	$x_{15}$	
Objective Function	$c_1$			$b_4$	$b_5$	$b_6$	$b_7$		$c_{10}$	$c_{12}$	$c_{13}$	$c_{14}$		
Land Balance	$A_{1,1}$													$\leq 4$
Irrigation & Livestock Drinking Water	$A_{1,2}$								$-1$					$= 0$
Irrigation Equipment	$A_{1,3}$									$-1$				$= 0$
Fodder Production	$A_{1,4}$	$-1$												$= 0$
Grain Production	$A_{1,5}$		$-1$											$= 0$
Grain Production Balance			$A_{1,6}$	$A_{1,6}$		$-A_{1,6}$		$-A_{1,6}$						$= 0$
Other Crop Production Balance				$-A_{1,7}$			$-A_{1,7}$							$= 0$
Livestock Feedstuff Requirements								$A_{1,8}$	$-A_{1,8}$					$\geq 0$
Livestock Products									$-1$					$= 0$
Fertilizers	$A_{1,10}$									$-1$				$= 0$
Machinery	$A_{1,11}$										$-1$			$= 0$
Capital Investments	$A_{1,12}$											$A_{1,12}$	$-1$	$= 0$
Constrained Irrigation Water									$1$					$\leq 2$
Constrained Fertilizers										$1$				$\leq 1$
Constrained Capital Investments													$1$	$\leq 1$
Population grain Products				$1$										$\leq 1$
Population other Products					$1$									$\leq 2$
Livestock Numbers														$\leq 1$

$\underline{c}_i$  = a vector of costs associated with aggregated activity  $\underline{x}_i$ ;

$\underline{b}_i$  = a vector of benefits associated with  $\underline{x}_i$ .

The objective function, OB, is maximized, subject to the following set of constraints:

Land Balance

$$\underline{A}_{1,1} \underline{x}_1 \leq \underline{\ell} \quad ,$$

where

$\underline{A}_{1,1}$  = a matrix relating irrigated and nonirrigated crop areas;

$\underline{x}_1$  = a vector of crop areas (in hectares);

$\underline{\ell}$  = a vector of available land in the subregions.

Irrigation and Potable Water Demands, and Irrigation Equipment

$$\underline{A}_{1,2} \underline{x}_1 + \underline{A}_{9,2} \underline{x}_9 - \underline{I} \underline{x}_{11} = 0 \quad ,$$

where

$\underline{A}_{1,2}$  = a matrix of unit crop water demands;

$\underline{A}_{9,2}$  = a matrix of unit livestock water demands;

$\underline{I}$  = the identity matrix;

$\underline{x}_{11}$  = a vector of irrigation and livestock water supply;

$$\underline{A}_{1,3} \underline{x}_1 - \underline{I} \underline{x}_{12} = 0 \quad ,$$

$\underline{A}_{1,3}$  = a matrix of irrigation equipment requirements on unit crop level;

$\underline{x}_{12}$  = the number of sets of equipment supplied.

Fodder and Grain Production

$$\underline{A}_{1,4} \underline{x}_1 - \underline{I} \underline{x}_2 = 0 \quad ,$$

$$\underline{A}_{1,5} \underline{x}_1 - \underline{I} \underline{x}_3 = 0 \quad ,$$

where

$\underline{A}_{1,4}$  and  $\underline{A}_{1,5}$  = matrices of yields associated with fodder and grain production, respectively;

$\underline{x}_2$  and  $\underline{x}_3$  = vectors of fodder, and grain produced and imported, respectively.

#### Grain Production Balance

$$\underline{A}_{3,6} \underline{x}_3 - \underline{A}_{4,6} \underline{x}_4 - \underline{A}_{6,6} \underline{x}_6 - \underline{A}_{8,6} \underline{x}_8 = 0 \quad ,$$

where

$\underline{A}_{3,6}$ ,  $\underline{A}_{4,6}$ ,  $\underline{A}_{6,6}$ , and  $\underline{A}_{8,6}$  = matrices associated with the total amount of grain produced and imported, population requirements of grains, reserves, and exports and grain products for livestock, respectively;

$\underline{x}_4$  = a vector of population crop products;

$\underline{x}_6$  = a vector of grain reserves and exported grain;

$\underline{x}_8$  = a vector of grain products for livestock.

#### Other Crop Production Balance

$$\underline{A}_{1,7} \underline{x}_1 - \underline{A}_{5,7} \underline{x}_5 - \underline{A}_{7,7} \underline{x}_7 = 0 \quad ,$$

where

$\underline{A}_{1,7}$ ,  $\underline{A}_{5,7}$ , and  $\underline{A}_{7,7}$  = matrices describing production of other crops (vegetables, tobacco, fruit, grapes); population requirements, and export of these crops;

$\underline{x}_5$  = a vector of other crops for the population;

$\underline{x}_7$  = a vector of exports of the other crops.

#### Livestock Feedstuff Requirements

$$\underline{A}_{2,8} \underline{x}_2 + \underline{A}_{8,8} \underline{x}_8 - \underline{A}_{9,8} \underline{x}_9 \geq 0 \quad ,$$

where

$\underline{A}_{2,8}$ ,  $\underline{A}_{8,8}$ , and  $\underline{A}_{9,8}$  = matrices of fodder products;  
grain livestock products, and animal diet requirements  
for these products, respectively;

$\underline{x}_9$  = a vector of animal numbers.

### Livestock Products

$$\underline{A}_{9,9} \underline{x}_9 - \underline{I} \underline{x}_{10} = 0 \quad ,$$

where

$\underline{A}_{9,9}$  = a matrix of livestock products generated by animals;

$\underline{x}_{10}$  = a vector of livestock products.

### Fertilizers, Machinery, and Capital Investments

$$\underline{A}_{1,10} \underline{x}_1 - \underline{A}_{9,10} \underline{x}_9 - \underline{I} \underline{x}_{13} = 0 \quad ,$$

$$\underline{A}_{1,11} \underline{x}_1 - \underline{I} \underline{x}_{14} = 0 \quad ,$$

$$\underline{A}_{1,12} \underline{x}_1 + \underline{A}_{9,12} \underline{x}_9 + \underline{A}_{12,12} \underline{x}_{12} + \underline{A}_{14,12} \underline{x}_{14} - \underline{I} \underline{x}_{15} = 0 \quad ,$$

where

$\underline{A}_{1,10}$  and  $\underline{A}_{9,10}$  = matrices of crop fertilizer  
requirements and manure generation, respectively;

$\underline{A}_{1,11}$  = a matrix of various machinery requirements in  
crop production;

$\underline{A}_{1,12}$ ,  $\underline{A}_{9,12}$ ,  $\underline{A}_{12,12}$ , and  $\underline{A}_{14,12}$  = matrices of capital  
investments for orchards, livestock farming houses,  
irrigation equipment, and machinery, respectively;

$\underline{x}_{12}$  = a vector of irrigation equipment;

$\underline{x}_{13}$  = a vector of fertilizers;

$\underline{x}_{14}$  = a vector of machinery types;

$\underline{x}_{15}$  = a vector of capital investments.

Constrained Input Resources

$$\begin{aligned} \underline{I} \underline{x}_{11} &\leq \underline{w} \quad , \\ \underline{I} \underline{x}_{13} &\leq \underline{f} \quad , \\ \underline{I} \underline{x}_{15} &\leq \underline{k} \quad , \end{aligned}$$

where

$\underline{w}$ ,  $\underline{f}$ , and  $\underline{k}$  = vectors of available amount of water, fertilizers, and capital investments, respectively.

Constrained Outputs

$$\begin{aligned} \underline{I} \underline{x}_4 &\geq \underline{g} \quad , \\ \underline{I} \underline{x}_5 &\geq \underline{p} \quad , \\ \underline{I} \underline{x}_9 &\geq \underline{n} \quad , \end{aligned}$$

where

$\underline{g}$ ,  $\underline{p}$  and  $\underline{n}$  = vectors of lower limit constraints on grain products (flour, cooking oil), other products for the population (vegetables, peaches, tobacco), and livestock numbers (cows, sheep, pigs, hens).

*Results of the Water Demand Model*

Associated with each of the questions needing to be addressed are a few key variables in the model: annual net benefit, irrigation capital investments, irrigated land to be developed, number of livestock, water demands in space and time, other constrained input resources (fertilizers, labor). To formulate a set of computer runs, these variables are assumed to take values within a certain range and the model is optimized for each of these values to obtain the required results.

The preliminary results<sup>1</sup> can be grouped in four sections: the first is validation of the model, in which the model's

---

<sup>1</sup>The results are preliminary because data change and become more accurate, and SWIM 3 and the other regional models are still being developed and refined.



results for a past year (1975) are compared with actual production statistics; the second considers investment in the development of irrigated land; in the third various forecast scenarios of the growth in water demands are made; and finally, the effect of not supplying all the water demands is examined.

### Validation of the Model

The objective of validation is to assess how closely the Water Demand Model reflects actual conditions in the agricultural process. It should be noted however, that as an optimization model it possesses internal decision-making capability to maximize net benefits subject to the set of constraints, and its solution may very well be different from what is currently practiced. In this context, the goal of validation is to ensure that the model adequately reflects the agricultural process in the Silistra region. This being so, the model can be used with confidence to suggest policies for situations different from those of the present.

In the process of validation, the production outputs for 1975 were compared with the model's results (Figure 4).

The model gives 0.6% less grains (maize, wheat, barley, soybeans, sunflowers), 24% less green fodder (alfalfa, maize silage), and 20% more livestock (cows, sheep, hens, pigs). This is in fairly good agreement considering that some of the 1975 production may not have been fed to animals and that the model was run on 1985 perspective data which do not correspond exactly to those of 1975.

### Irrigated Land Development

The development of irrigated land requires extensive capital investment to provide supply facilities at the water source, canals or pipes to deliver water to the field, and equipment to apply the water to the crops.

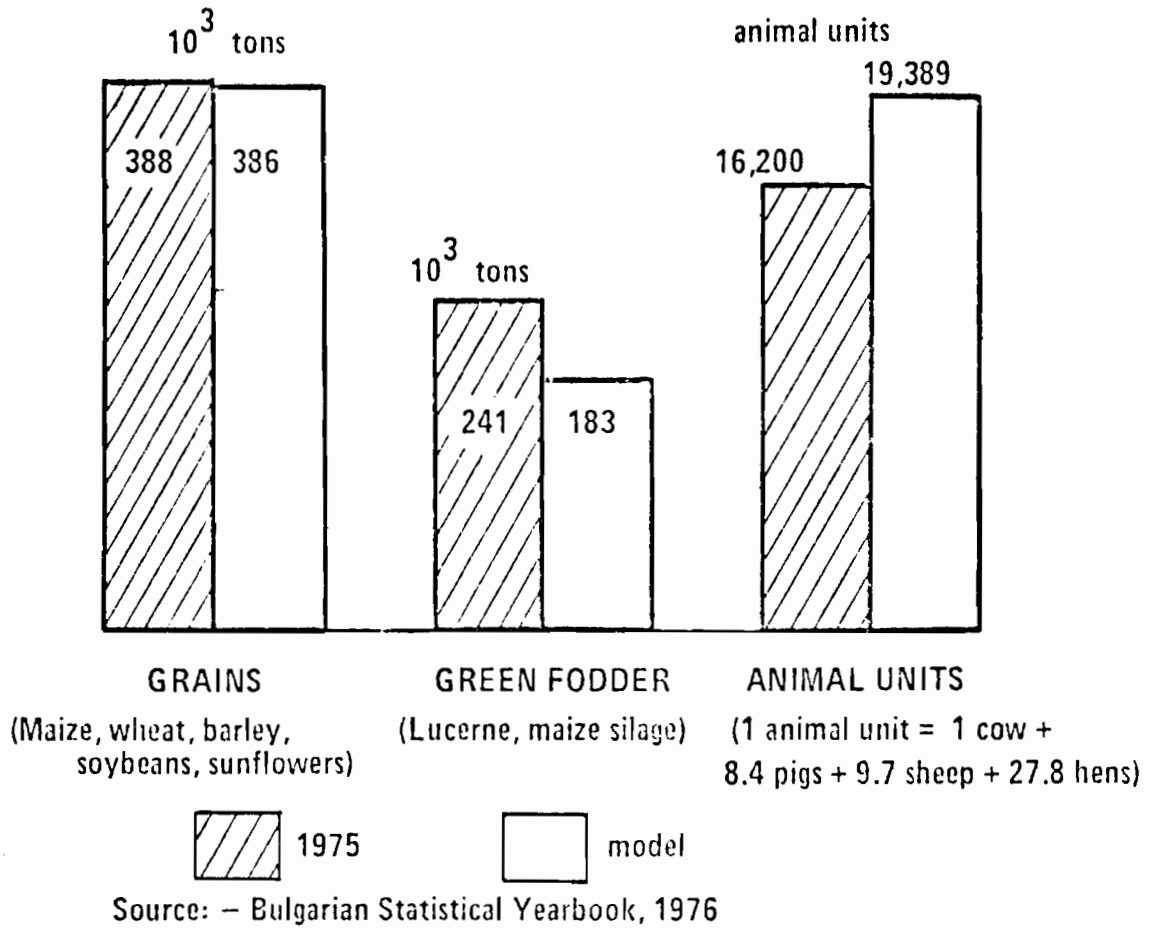

Figure 4. Comparison of production in the Silistra region.

It is generally true that developing irrigation land increases both benefits and costs of an agricultural enterprise because production is intensified. The net benefits (benefits minus costs) of irrigation development are usually positive, but it is normally the case that as additional land is irrigated, each increment generates a smaller increase in the net benefits over the whole region, i.e. there are diminishing marginal returns on the investment. If one keeps increasing the irrigation investment a point can be reached at which the marginal cost of additional irrigation equals its marginal benefit. This point can be considered as the optimal economic level of irrigation development.

The principle of diminishing marginal returns on investment is illustrated in Figure 5, which (due to irrigation) represents the additional net benefit in the Silistra region as a function of the irrigation investments. The optimal economic investment is approximately  $320 \times 10^6$  Lv (1 Lv = 1\$). This is the point of maximum benefits and the model does not utilize any further investment funds made available. It should be noted that the investment shown in Figure 5 is just a total; it has no time dimension and could actually be provided in increments over many years (more details about the investment's time dimension are given in the paragraph devoted to forecasting of water demands).

The diminishing marginal returns on investment are also illustrated in Figure 6, which is actually the demand curve for irrigation investments.

The irrigation investments to deliver water to the field are different for each of the subregions. It is to be expected that as more investment funds are provided the lower cost subregion will be developed first (Figure 7). Subregion 3 is developed first to the limit of its potentially irrigable area, followed by subregion 1 and 2. The optimal economic investment is reached before subregion 2 is developed to its limit. The corresponding optimal economic irrigation area is 105.000 ha, which is 70% of the arable land in the region. The demands

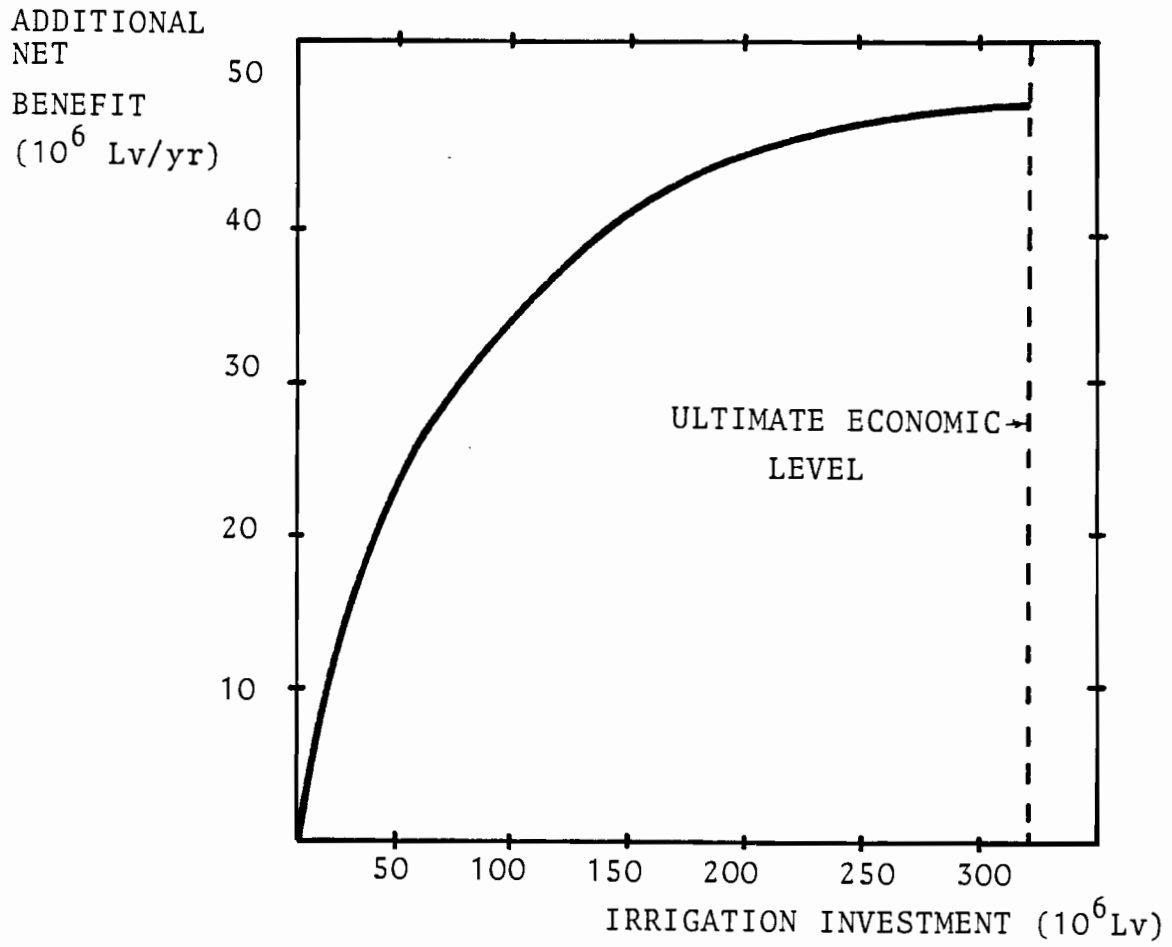

Figure 5. Benefits of irrigation investment.

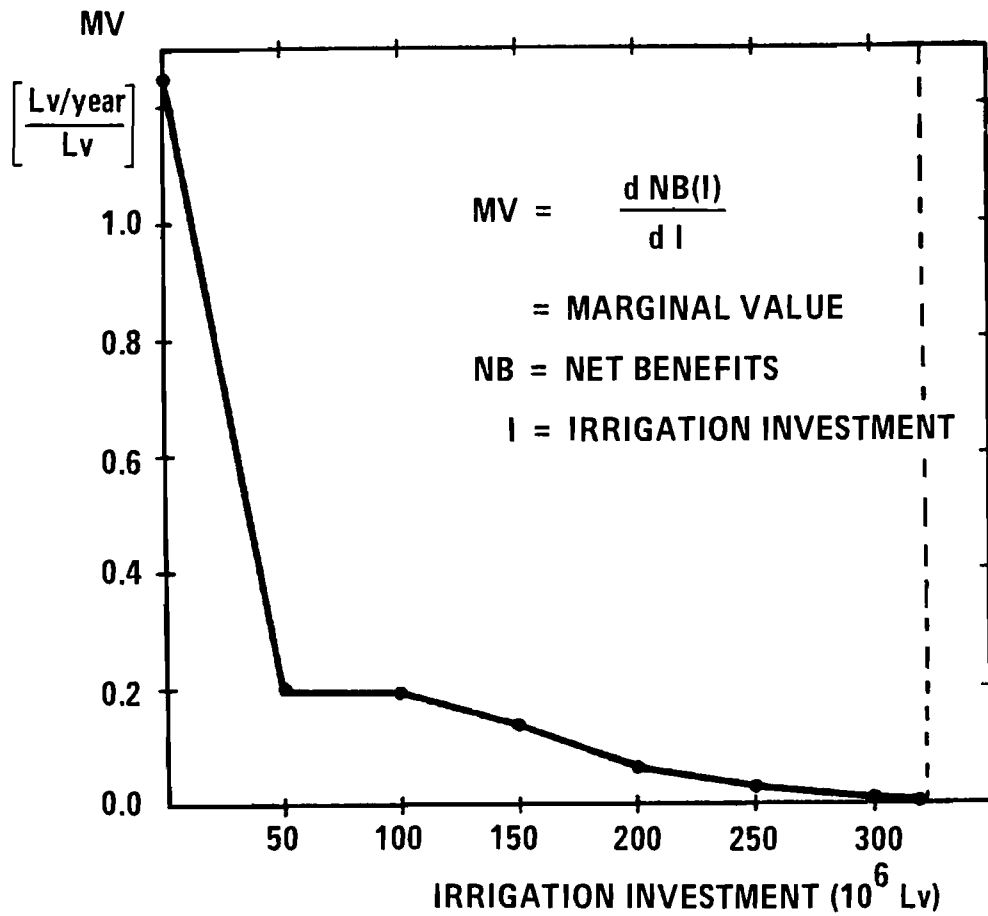

Figure 6. Marginal value of irrigation investment.

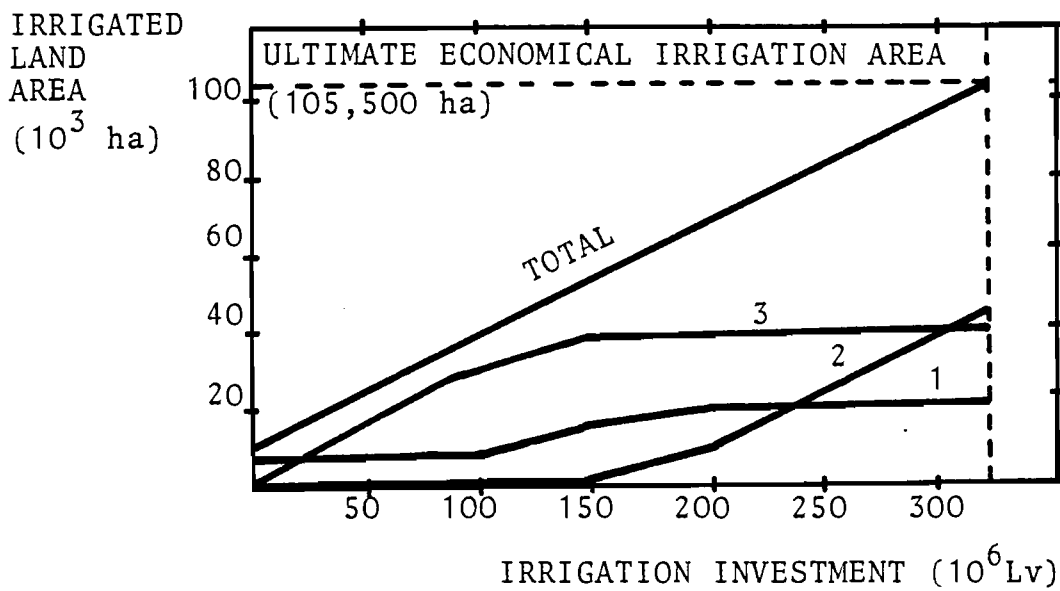

Figure 7. Development of irrigation land by subregions 1, 2 and 3.

for water which would result from developing the irrigated area are shown in Figure 8 for average and dry weather. These demands increase approximately linearly with increasing irrigated area to amounts of  $585 \times 10^6 \text{ m}^3/\text{year}$  (average weather) and  $820 \times 10^6 \text{ m}^3/\text{year}$  (dry weather). The corresponding water withdrawal coefficients are  $5500 \text{ m}^3/\text{ha}$  (550 mm) under normal weather and  $7750 \text{ m}^3/\text{ha}$  (775 mm) under dry weather conditions. Since an irrigation efficiency of 50% is assumed (5% conveyance losses, 30% application losses, and 15% for leaching of salts) these coefficients correspond respectively to 275 mm and 387 mm for use of irrigation water by the crops over the irrigation season.

### Water Demand Forecasting

Forecasts of water demands are the basis for the design of supply facilities. Two types of information are needed: the volume which will be demanded in future years, and the distribution of this volume within a given year to produce flow rates. In the Silistra region the growth in water demand over time is linked to the overall agricultural development of the region in which the numbers of livestock are the primary decision variables.

There are at least two ways to forecast the number of livestock:

- developing a set of scenarios each corresponding to specified future growth rates in the number of each type of animal;
- linking the water demand model to the agricultural model: the latter can provide the forecasted numbers of animals in the region and these numbers can be fed into the water demand model as exogenous variables.

Both ways have been examined so far. To illustrate the results the scenario approach will be briefly discussed.

Four scenarios have been formulated with equal animal growth rates for each type of animal of 2%, 4%, 5% and 10%, respectively. Two additional scenarios emphasizing cows have

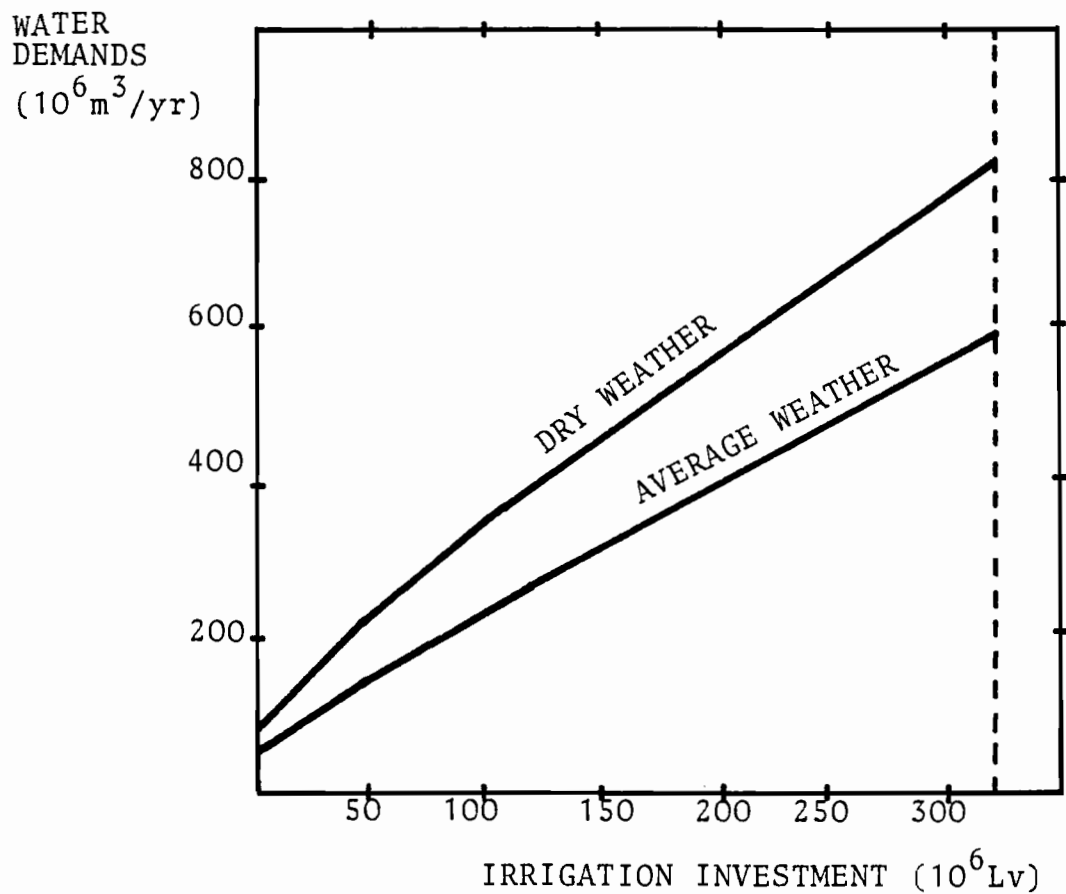

Figure 8. Demand for water in normal and dry weather.

also been formulated, one in which the number of cows grows at 5%/year and the other animals at 2%/year; and another in which cows grow at 10%/year, the others at 5%.

Having developed the scenarios, one can feed the numbers into the model. The model is run for 1980, 1985, 1990, 1995, and 2000 to determine the associated crop production, irrigated area, and water needed to support the fixed number of livestock. The results for normal weather conditions are shown in Figure 9. For the faster growth scenarios the optimal economic level of development is reached before the year 2000 so the forecast was terminated at that level. Figure 9 indicated that water demands grow about 4-5 times faster than the number of livestock. For example, under 5% annual livestock growth rate, water demands increase from  $78.1 \times 10^6 \text{ m}^3$  in 1975 to  $340 \times 10^6 \text{ m}^3$  in 1990, an increase of 335%, or 22% per year. This scenario involves developing the irrigated area at the average rate of 3000 ha/year involving average investment of  $10 \times 10^6 \text{ Lv/year}$  in irrigation. The allocation of capital investment for this scenario, from 1980 until the optimal economic irrigation level is reached, is shown in Figure 10.

The model also computes the distribution of water demands over the irrigation season to identify the peak demand rate which serves as the base for designing the pumping stations, canals, and pipes. A smoothed distribution of demand over the irrigation season is shown in Figure 11 for 1985 and 1995 for the "5% all" scenario. The peak demand rises from  $40.2 \times 10^6 \text{ m}^3/10 \text{ days}$  in 1985 to  $79.2 \times 10^6 \text{ m}^3/10 \text{ days}$  in 1995.

#### Allocation of Scarce Water Resources

If water is a scarce resource, it may be useful, when considering its allocation among various users, to derive the demand function for each particular use to measure the marginal net benefit of transferring a unit of water from one use to another.

The demand function for water can be derived by



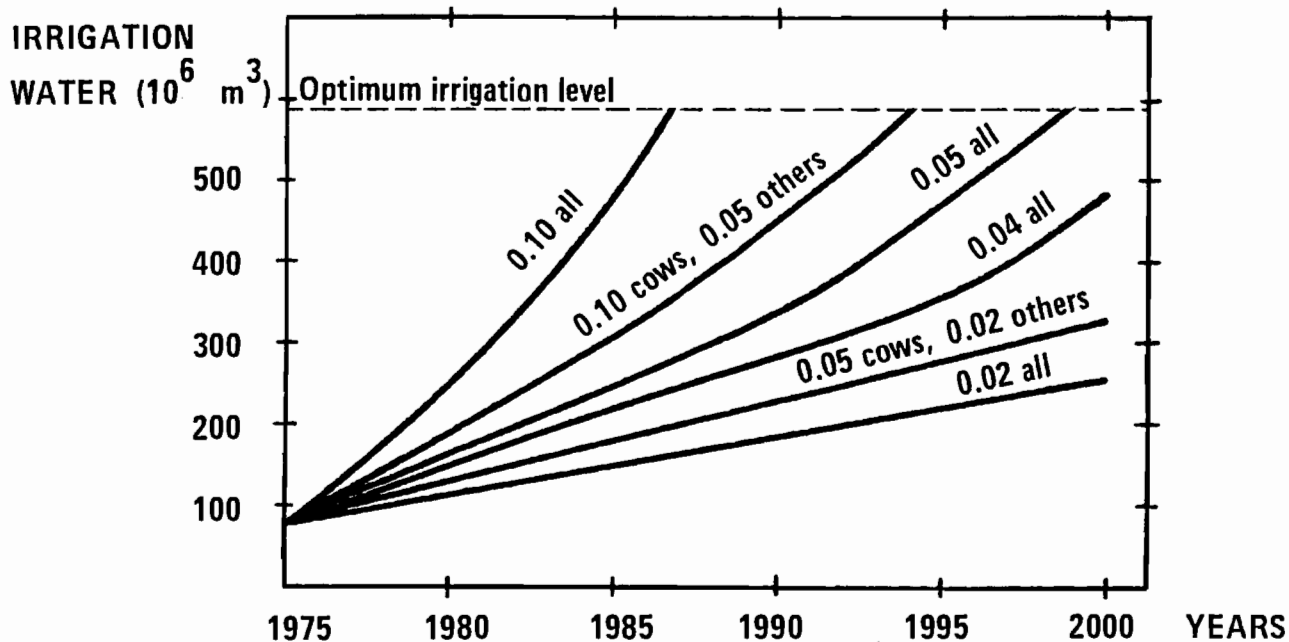

Figure 9. Comparison of water demands forecast scenarios.

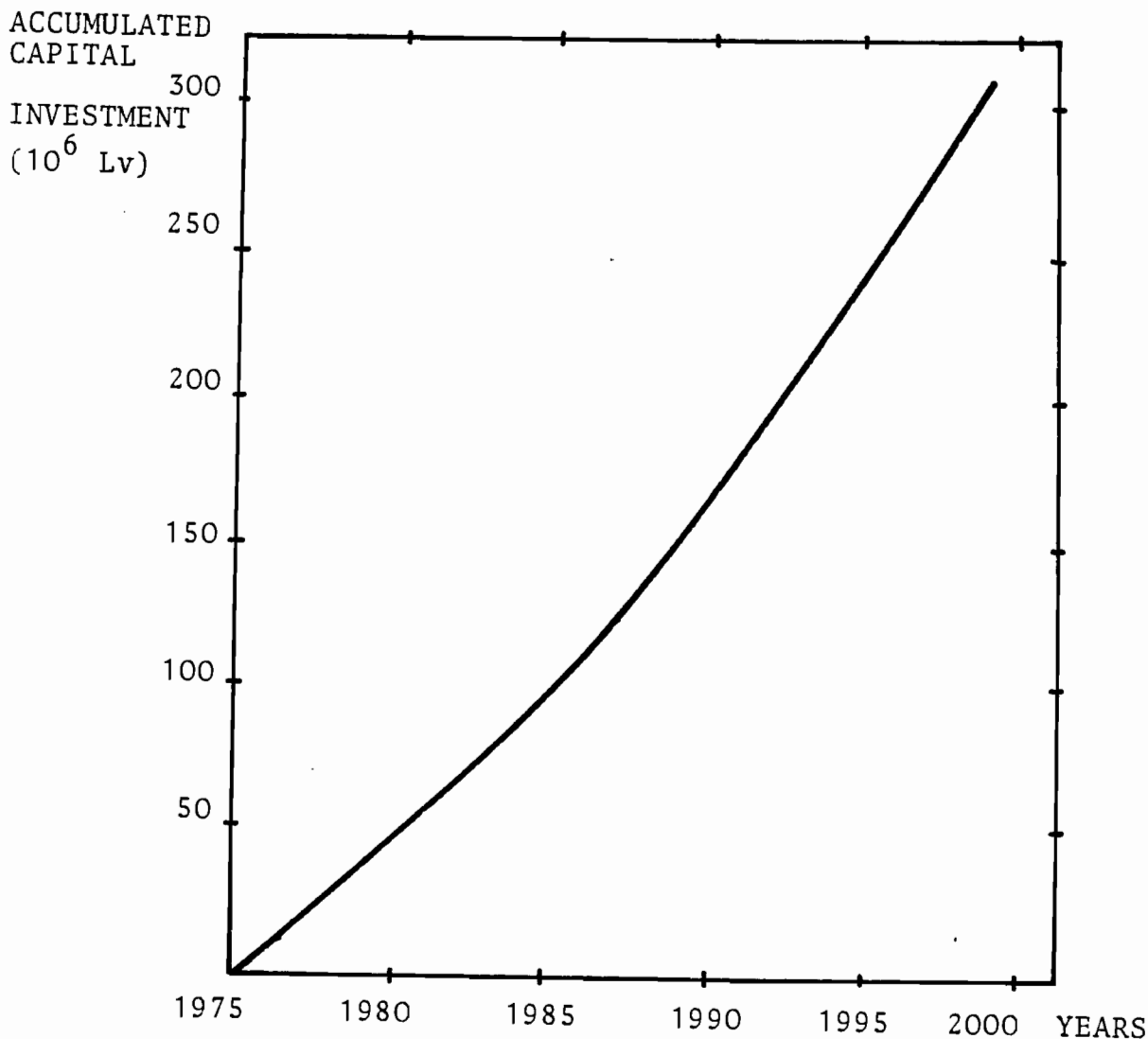

Figure 10. Accumulated capital investment in time ("5% all" scenario).

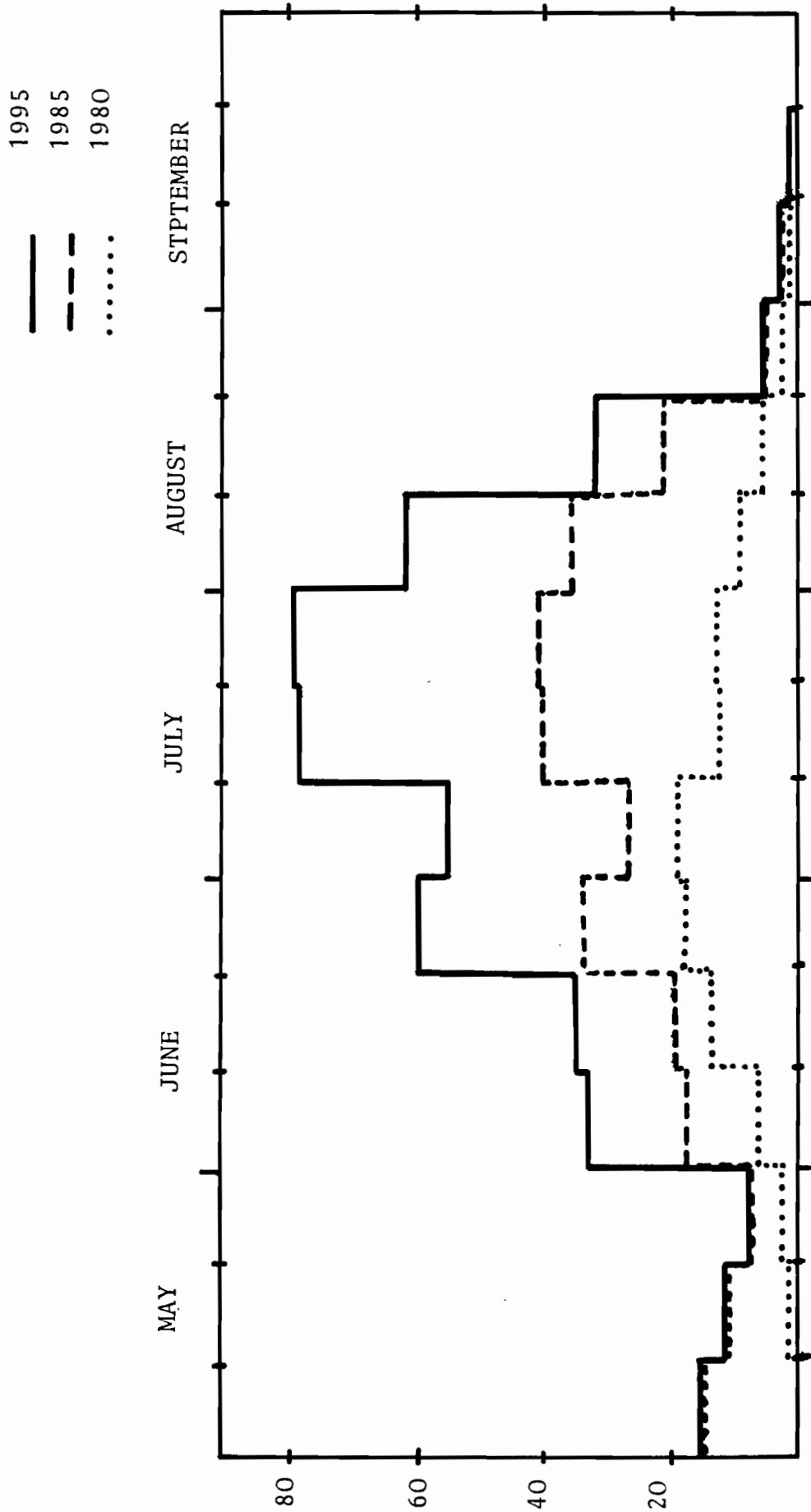

Figure 11. Distribution of water demands in time ("5% all" [5% livestock growth] scenario).

differentiating net benefits from Figure 5 with respect to water demands from Figure 8. In the model the demand function is found more readily as the dual value (or shadow price) of the constraint on water when all other input resources, except land, are unconstrained (Figure 12). There are 17 points on this function. At each point something changes in the model solution; for example, a different crop is irrigated or the animals' diets are changed.

As is the case in most irrigation areas of the world, the water price ( $0.017 \text{ Lv/m}^3$ ) charged in the Silistra region is very small compared with its marginal value. The equilibrium point at  $585 \times 10^6 \text{ m}^3/\text{year}$  is where the price of water equals its marginal benefit, and this is what actually determines the optimal economic level of development identified previously. The unit cost of water, based on the cost of the supply facilities, is estimated to be approximately  $0.13 \text{ Lv/m}^3$  in the region. If this were charged as the water price, the water demands at the equilibrium point would fall to  $275 \times 10^6 \text{ m}^3$ , which corresponds to 51,000 ha of total irrigated land. The water demands of the 10,000 ha currently irrigated have very high marginal values, however, and would be unaffected even if such a price were charged.

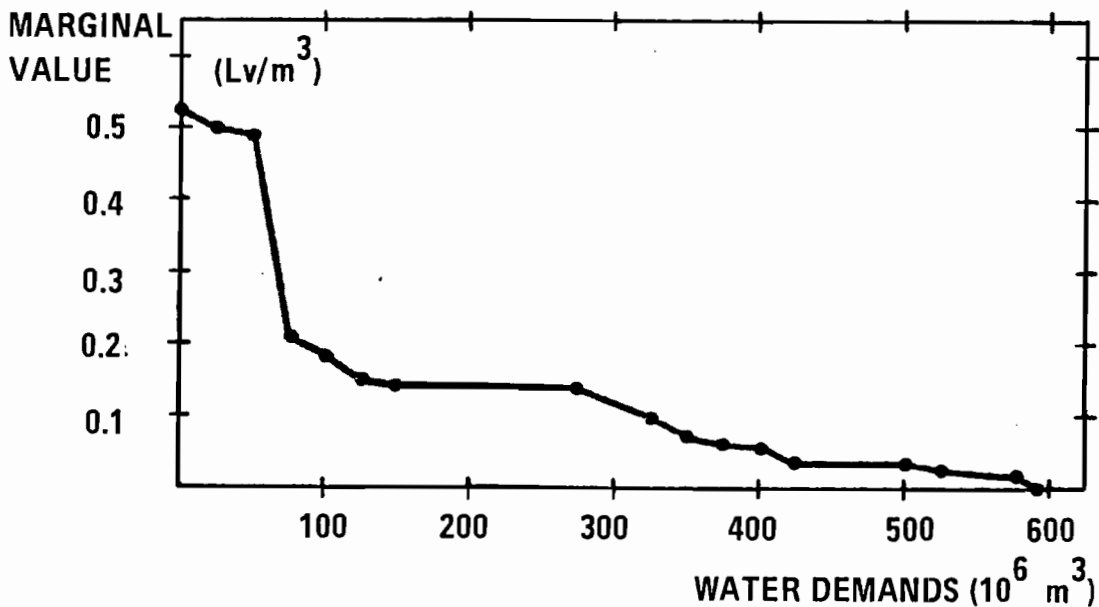

Figure 12. Demand function for irrigation water.

COORDINATION OF THE AGRICULTURAL WATER  
DEMAND AND WATER SUPPLY MODELS

Demand-supply coordination is one of the key concepts in water resources development. It is based on the assumption that if water in a given region is becoming scarce the marginal cost of supply increases because more distant or costly water sources are utilized. At the same time, the net benefit from using this amount of water decreases. The problem is to find such water demands for which the marginal benefit of increasing demand is equal to the marginal cost of providing the supply, i.e. an equilibrium in the system is achieved.

The theory of demand-supply coordination indicated two general approaches to carry out the coordination problem:

- developing a unified demand-supply model whose solution is internally coordinated;
- interaction between the demand and supply models until an equilibrium is achieved.

In the demand model discussed in Section 4, a simplified version of the first approach was implemented, i.e. the supply costs were assumed to be constant over the entire water demand range.

To apply the second approach, the key coordination variables in the demand and supply models have to be identified. For the Silistra agricultural water demand and supply models, these variables are shown in Figure 13.

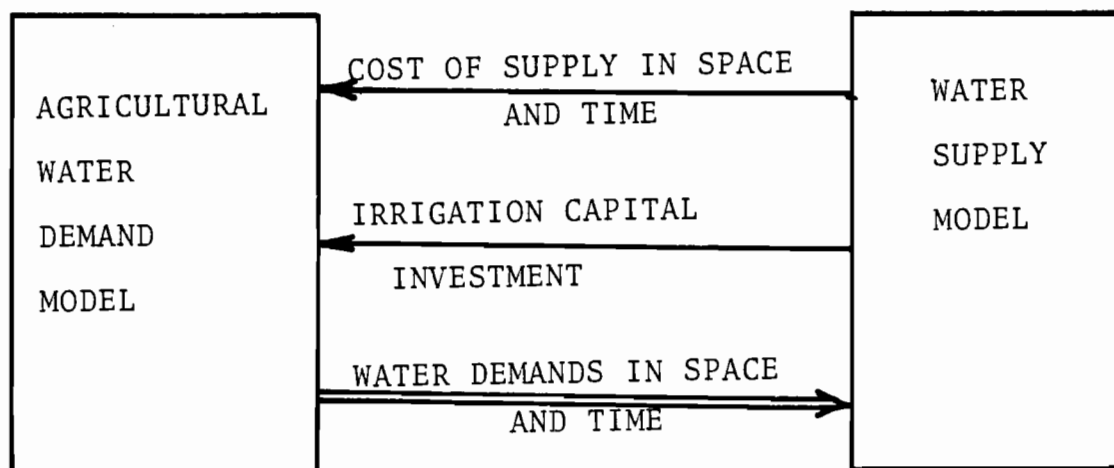

Figure 13. Water demand-supply coordination parameters.

The demand model provides the supply model with water demands in space and time. Based on these demands, the supply model generates the least-cost alternatives which can meet these demands, as well as the current costs and required capital investment costs of doing so. The costs are fed back to the demand model. The modified demand, reflecting the new cost and investments, are then obtained. This procedure can be implemented in an interactive way several times until satisfactory results are obtained. "Satisfactory results" means the following.

It may be economically desirable to obtain an equilibrium solution for which the costs of one unit of additional water supplied equals the benefits from this amount of water. Decision makers may wish, however, not to keep strictly to the equilibrium in order to fulfill other goals not explicitly incorporated in the models. For example, the decision makers may subsidize water as an incentive to increase agricultural production. Therefore, the coordination process shown in Figure 13 has to be implemented with participation of the decision makers responsible for the overall regional development.

It should be pointed out that although there are only two coordination parameters between the agricultural water demand model and water supply model, the latter has to be coordinated with the industry, transportation, recreation, and potable water demand models. When referring further to water resources development models we shall assume that all these models interact with the other regional models.

COORDINATION OF THE WATER RESOURCES DEVELOPMENT  
MODEL AND OTHER REGIONAL MODELS

Water resources development must adjust to changing human needs, social values, and environmental policies, institutions, and technologies. The data base used should provide the following advantages for analyzing alternative scenarios:

- data should be available for running models at any time regardless of the readiness of other models, i.e. the coordination of models must not necessarily be done at the same time;
- interaction among models will be greatly facilitated because any change in input data or results of a certain model will be recorded and displayed for use in running other models.

Figure 14 indicates the coordination parameters between the water resources development model and the other regional models. The data communication process among the models is to be carried out through the regional data base. The basic parameters which have to be exchanged among the models are as follows:

- Agriculture → Water resources: crop and livestock production alternatives: technological coefficients (yields, input resource rates, animal diets), production constraints (targets of crop and livestock production as well as their exports and imports), number of animals, lay-out of farming houses.
- Water resources → Agriculture: irrigated land, water demands in space and time, cost of water supply (for subregions over the irrigation season).
- Industry → Water Resources: production alternatives, technological coefficients, production constraints and targets, lay-out of enterprises.
- Water resources → Industry: water demands; cost of supply

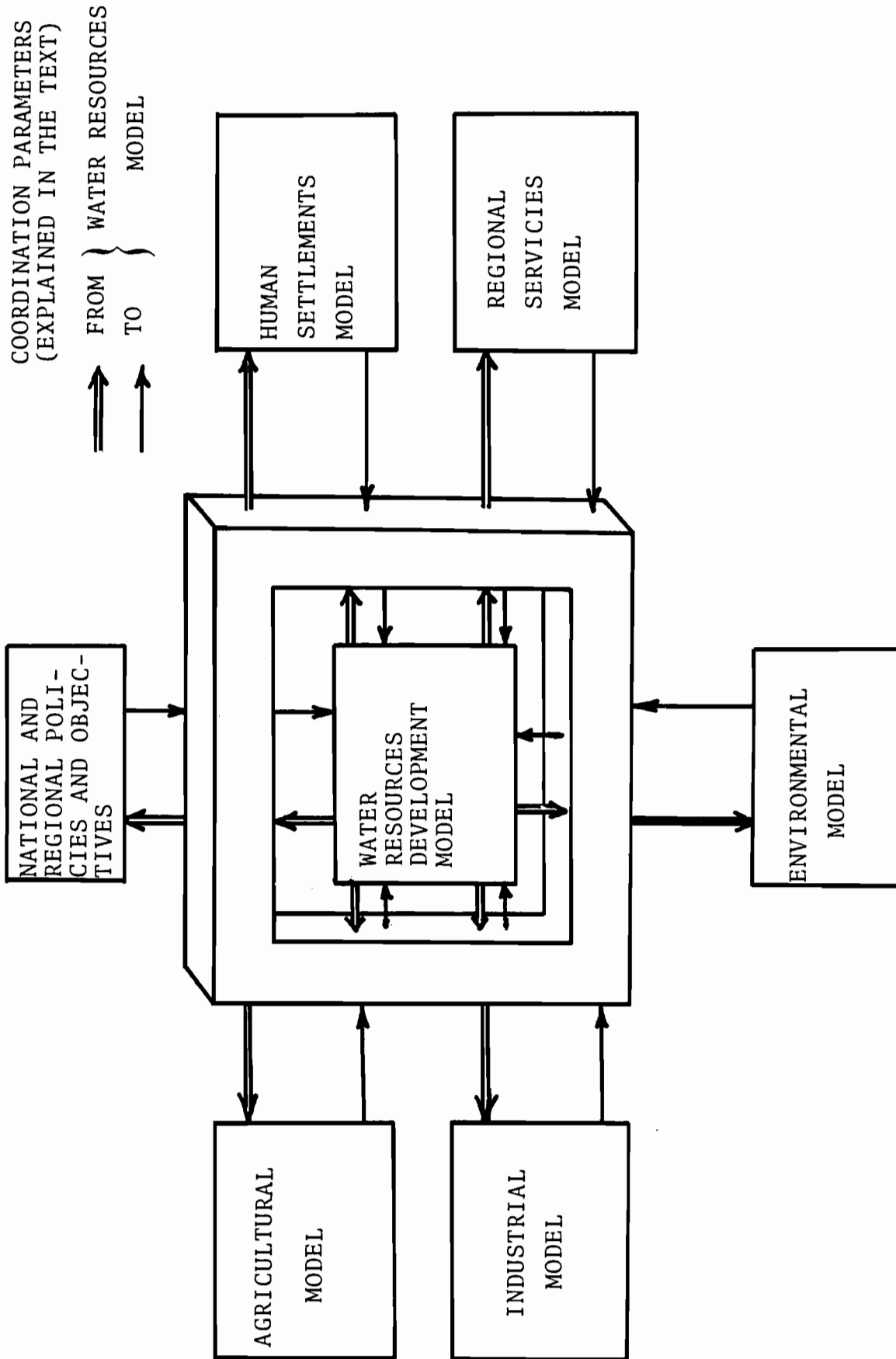

Figure 14. Coordination of water resources development model and other regional models.

- Human settlements → Water resources: number, spatial and temporal distribution of population; standard of living.
- Water resources → Human settlements: water demands; cost of potable water supply.
- Environment protection → Water resources: environmental standards and constraints (salinization of soil, water logging, chemical build-up, unpleasant odors).
- Water resources → Environmental protection: lay-out of water resources facilities.
- Regional services (transportation, recreation, etc.) → Water resources: lay out and size of regional services facilities.
- Water resources → Regional services: water demands; cost of water supply.

It should be pointed out that the coordination between the water resources development model and the other regional models is rather involved and consumes computer time, but the outcome is beneficial. This has already been proved in the process of coordination of the water demand and agricultural models.

#### CONCLUSIONS

There are many objectives and alternatives for development of the Silistra region. Water resources will have a great impact on the development of the region because of water scarcity within the region and the need for costly transferal of Danube water. To cope with this situation the paper suggests implementation of two interacting models: a water demand and a water supply model.

Some of the preliminary results of the demand model are presented dealing with the optimal economic level of irrigated land development (identifies as the point where 70% of the potentially irrigable land is developed for irrigation), deriving and forecasting of water demands in space and time, and impact of constrained input resources on the agricultural production process. It is shown that the level of irrigated



land development is quite sensitive to the price of water. Removing the existing price subsidy on water would reduce the optimal economic irrigation area to about 35% of the arable land.

The advantage of the water demand model is that it integrates the agricultural demands with the crop and livestock production process which determines these demands. This allows for changing inputs to the production process (e.g. changing the composition of animals' diets) and the production processes themselves (e.g. changing crops, converting land to irrigation). The integrated nature of the model is particularly important in the Silistra region because it corresponds to the centralized management structure controlling all aspects of agricultural production.

The next step in modeling of water resources development is to integrate the demand and supply models to obtain economic equilibrium solutions to be presented to the Silistra decision makers. An attempt should be made to coordinate these two models and the other regional models using the procedure suggested in this paper.

REFERENCES

- Albegov, M., and V. Chernyatin (1978) An Approach to the Construction of the Regional Water Resources Model. RM-78- Laxenburg, Austria: International Institute for Applied Systems Analysis.
- Gavrilov, G., S. Stoykov, C. Milenkov, and A. Kehajov (1978) Dynamic Linear Model of a Large Agricultural Industrial Complex CP-78-00 (forthcoming. Laxenburg, Austria: International Institute for Applied Systems Analysis.
- Gouevsky, I., and D. Maidment (1977) Agricultural Water Demands: Preliminary Results of Silistra Case Study. RM-77-44. Laxenburg, Austria: International Institute for Applied Systems Analysis.
- Gouevsky, I., D. Maidment, and W. Sikorski (1978) Modeling of Agricultural Water Demands: Completion Report of the Silistra Case Study. RR-78-00 (forthcoming). Laxenburg, Austria: International Institute for Applied Systems Analysis.

A WATER SUPPLY MODEL FOR THE  
SILISTRA REGION

M. Albegov, V. Chernyatin and  
A. Stanoulova

This report outlines the cooperative work being done by IIASA and the Sofia Institute on the modeling of a water supply system for the Silistra region. First, some general points concerning the modeling of a regional water supply are considered then an outline of the Silistra water supply model is presented.

The economic development of a region depends on many factors. Of these, water resources can be particularly important. Not only does water resource availability influence the production specialization of a region, it actually determines the development of irrigated agriculture, industries with high water consumption, and industries with severe water pollution, etc. Of course, the regional planner is interested not so much in what a regional water supply system should be, as in what the influence of water resource availability is on regional development. In essence, he would like to know:

1. Is it possible to meet the projected water demands?
2. What are the costs associated with the creation of an adequate regional water supply system?

Unfortunately, it is impossible to answer these questions, even roughly, without some analysis of the regional water

supply system itself.

To some extent, answers to these questions are related to the development of the region as a whole. Decisions concerning the location of production units within a given region are very sensitive to unit water costs for different geographical points and different time periods. In fact, an analysis of the Silistra agricultural model shows that unit water costs are among the main factors in determining regional water demands. Unit water cost depends on:

1. The geographical location of the water user
2. The quantities of water consumed by the other water users.
3. The season of the year

It should be stressed that we are dealing solely with cost rather than price of water.

In our opinion, taking into account such interdependencies in a regional production model, especially an agricultural model, would make that model impractical to use due to the increasing dimensionality and non-linearity of the problem .

As previously stated, the determination of unit water costs as functions of geographical location, water consumption, and season is impossible without some analysis of the regional water supply system. We would like to stress that it is hardly possible to correctly define unit water costs other than as marginal costs. As a rule, each water supply facility is multipurpose, and one cannot correctly allocate its capital costs according to the different water uses. Therefore, the a priori determination of unit water costs is extremely difficult.

That is why we attach great importance to the close integration of the water demand and water supply models. As Figure 1 illustrates, the water demand model, using unit water costs as one of its inputs, generates water demands as one kind of output. Conversely, for the water supply model, water demands are the main input and unit water costs are one of its outputs. Depending on the difference between the a priori and the endogenously determined costs, the water demand model

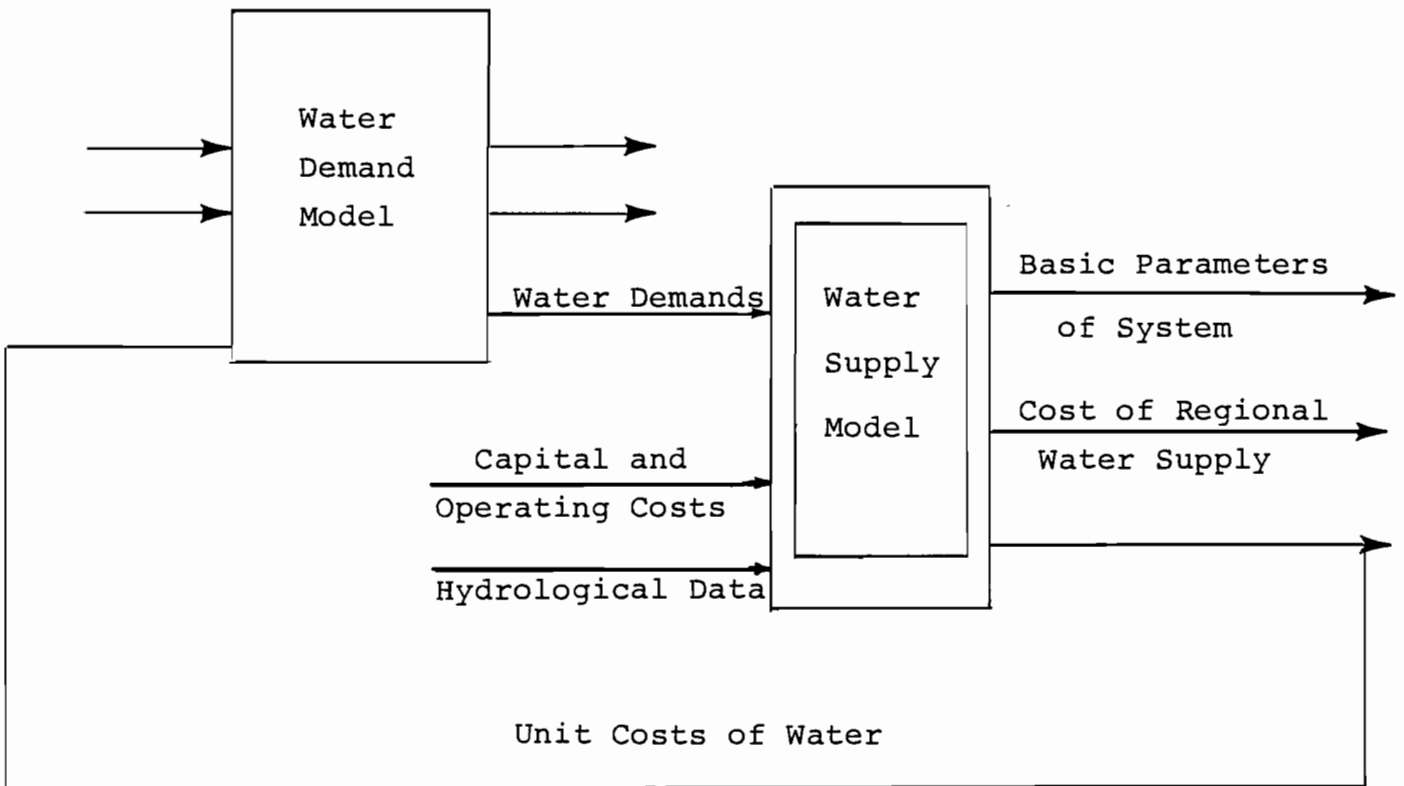

Figure 1. Interrelations between water demand and supply models.

corrects the water demands and directs them to the input of the water supply model, etc. Thus, we are dealing with an iterative process which is supposed to be convergent. Such an iterative process allows us to solve the problems of water demand and supply separately.

Many kinds of well elaborated water supply models already exist. Brilliant examples include the model developed in the United States by the Texas Water Development Board (1) and one developed in the Soviet Union by the Institute for Water Problems (2). Models such as these consider many specific situations in detail, including annual fluctuations in runoff, stochastic water demands, operating rules for each reservoir and canal, etc. These considerations are necessary for the exact calculation of a water resource system, but can be omitted when analyzing regional development.

However, these models do not cover a number of topics of significance to the regional planner, such as the dynamics of a water supply system during the planning period, the dependence of unit water costs on the factors listed above, and others.

It should be mentioned here that regional analysis implies the examination of a number of regional development alternatives. Therefore, a regional water supply model should not be oversophisticated, but operational.

Thus, we were forced to develop our own version of the regional water supply model that differed in many respects from the more detailed and sophisticated models already developed. In doing so, our main objective was to assess the water resource factor in regional planning rather than to develop a new technique for calculating a complex water resource system. In this context, the water supply model should provide the regional planner with the following essential data:

1. feasibility of the projected regional water demands,
2. the total cost associated with the creation of a regional water supply system,
3. the spatial and seasonal unit costs of water.

In the operational sense, the regional water supply model is a subordinate submodel in the regional system of models.

Many of these general principles have been implemented in the Silistra water supply model. The work is being carried out in close cooperation with the Sofia Institute for Water Systems Design. The relatively small size of the Silistra region as well as the ready availability of data make it an especially attractive subject for modeling.

The nature of water demand in the Silistra region requires that the water supply system be divided into two different parts: one for industrial and private use, and the other for irrigation.

About 10-15% of the total water demand comes from industry and the general population. Both require that the water be of drinking quality, since the major industry of the Silistra region consists of food enterprises. There are some non-food industries in the city of Silistra. However, they are located on the banks of the Danube and already have their own small water supply systems. The only source of drinking water is stream-terrace waters. This is a limited water source and can not be relied upon for agricultural use as well. In a technical respect, the drinking water supply system is a watermain system and is of interest solely for engineering.

The soil and climatic conditions of the Silistra region make it a particularly favorable area for the intensive development of irrigated agriculture. Fortunately, water for irrigation is available in virtually unlimited supply from the Danube. The entire Silistra region can be divided geographically into three non-connected irrigation systems. (Fig. 2). In the Tutraken system, this project is already under way and is, in fact, half finished. Thus, there is no further need for modeling. The topography in the Silistra irrigation system is such that the creation of reservoirs is impossible. And, since canal tracks have already been chosen, the development of the water supply system in this area is mainly a matter of engineering. Of the three irrigation systems, M. Preslovats is the most representative of the entire region with regard

# SILISTRA REGION

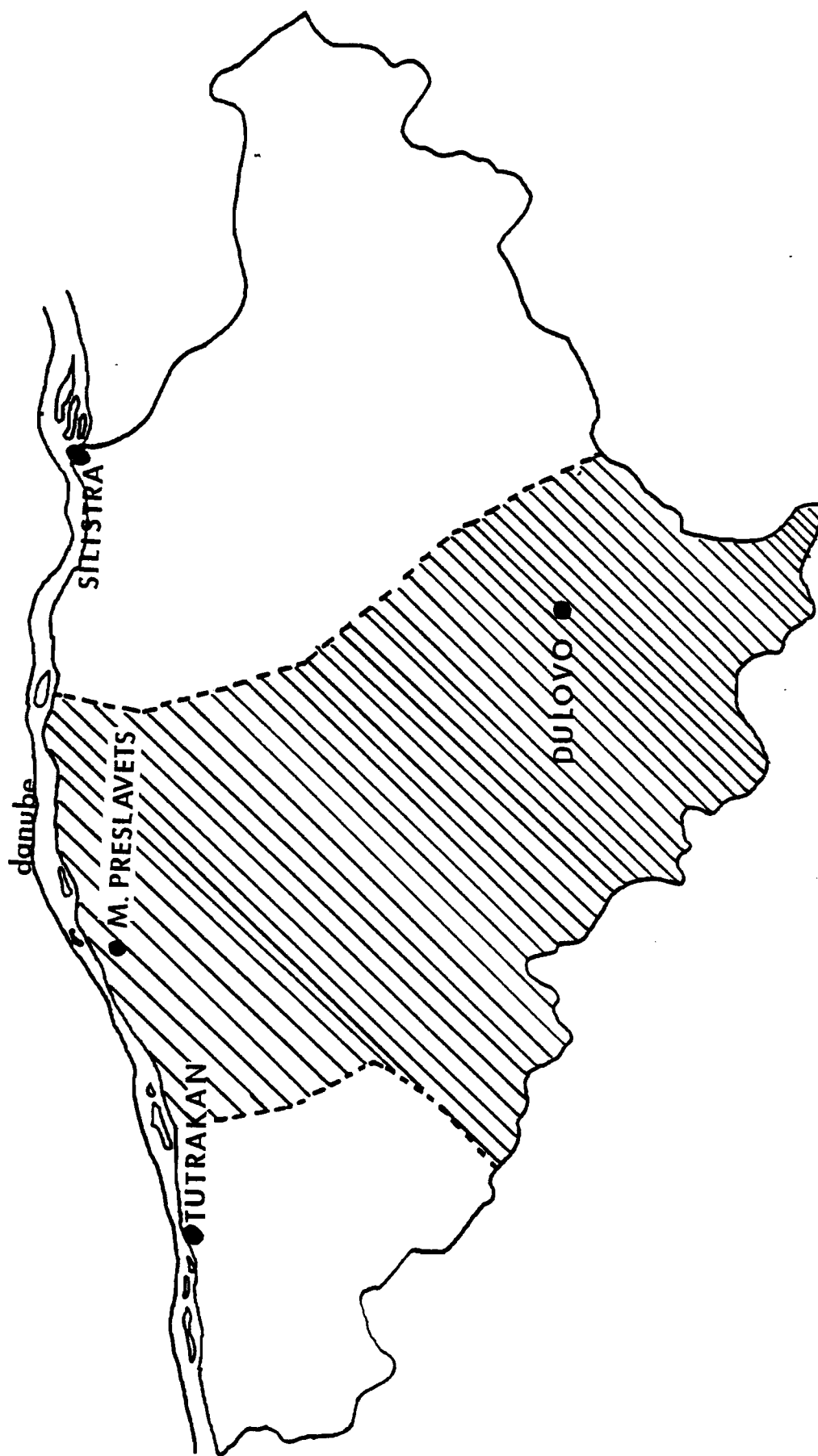

Figure 2. Silistra region.



to the irrigated area (about 60%), and such typical elements as reservoirs, pumping stations, canals, etc. Thus, we consider the M. Preslavets irrigation system as an ideal one for modeling a regional water supply system.

The main goal of water supply modeling in the Silistra case is to determine:

1. the basic parameters of the system;
2. the capacities of reservoirs and pumping stations;
3. the discharge capacities of canals;
4. the total cost associated with the creation of an irrigation system;
5. the spatial and seasonal unit costs of water.

The simplified structure of the M. Peslavats irrigation system used in our model is shown in Figure 3. It includes the main pumping station on the Danube streamflow, three reservoirs, five canals, and five water withdrawal outlets for irrigation. This structure differs from the actual situation only in the number of canals and water withdrawals. Such a simplification was necessary only because of the limited capability of the computer facilities available at IIASA.

The main initial assumptions for modeling are:

1. The water supply system cannot be altered after the end of the planning period (ca. 1990).
2. The water resources available are unlimited.
3. The projected water demands are specified at the beginning of the planning period.
4. Only the within-year regulation of water resources is considered.
5. Generalized annual costs, including both capital investments and operating costs, are minimized.

A few words should be said about the mathematical model. The decision variables are: water flow in the canals at different time periods, amount of water actually stored in the reservoirs, discharge capacities of the canals, and storage capacities of the reservoirs. The physical constraints of the model are the balance relations in the different modes of the water network. The objective function includes the following costs associated with the reservoirs, pumping stations, and canals:

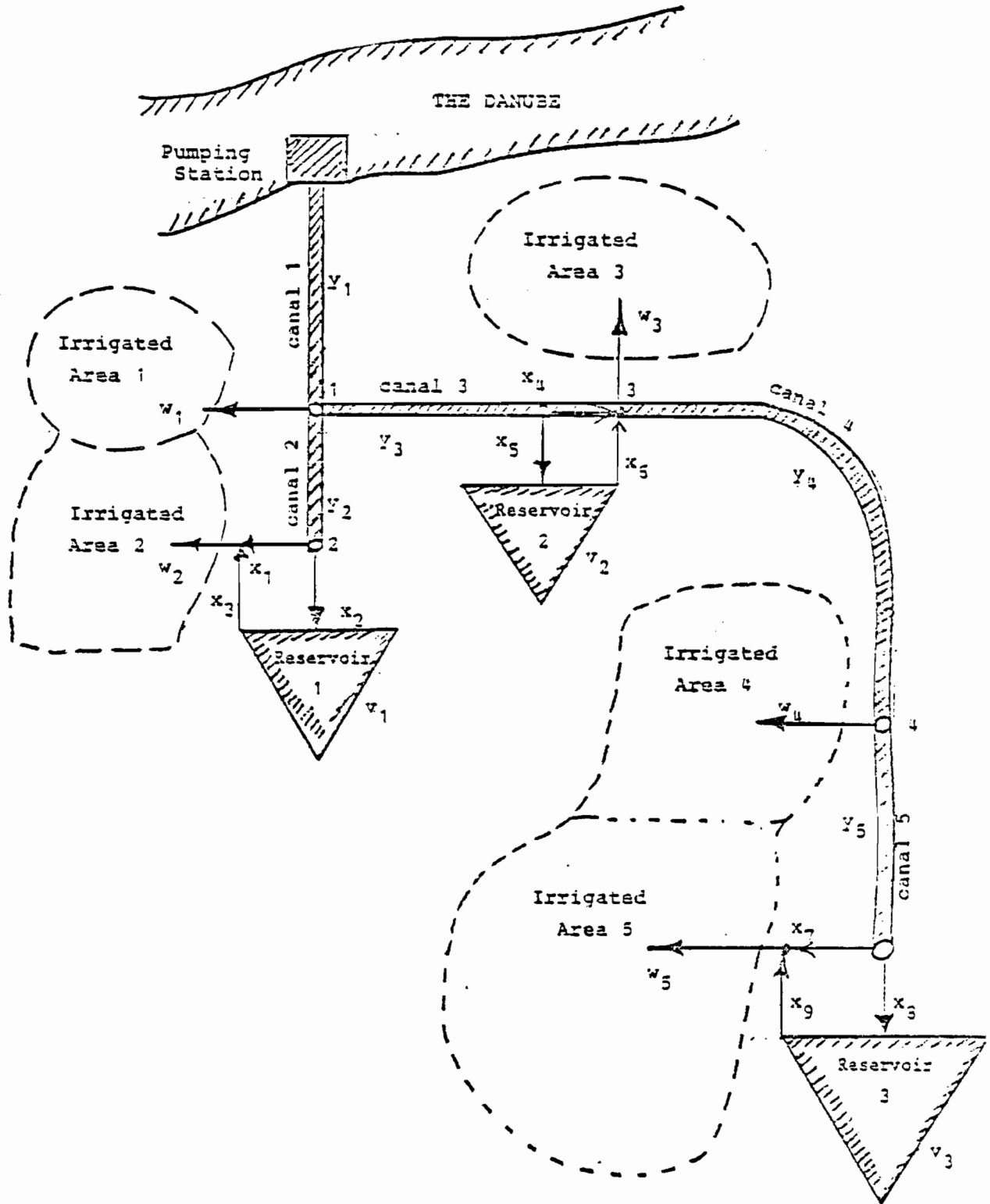

Figure 3. Scheme of the Silistra migration system.

Reservoirs		Pumping Station	Canals					Total Cost	Mean Unit Cost of Water
1	2		3	4	5				
14.7	30.7	9	1.65	4.92	7	3.08	21.6	0.123	
10 <sup>6</sup> m <sup>3</sup>			m <sup>3</sup> /sec					10 <sup>6</sup> lv	lv/m <sup>3</sup>

Figure 4a. Basic parameters of the Siliistra water supply system.

Seasons

Irrigated Areas	Seasons						
	1	2	3	4	5	6	7
1	1.4	3.1	1.4	4.01	11.4	1.4	1.4
2	1.7	3.41	3.41	4.9	4.9	1.7	1.7
3	2.16	4.56	4.56	4.56	4.56	2.16	2.16
4	2.76	5.16	5.16	5.34	19.1	2.76	2.76
5	4.34	5.84	5.84	5.84	5.84	4.34	4.34

10<sup>-2</sup>lv/m<sup>3</sup>

Figure 4b. Unit costs of water.

1. annual capital costs,
2. operating costs,
3. annual costs associated with the electrical energy for pumping water,
4. annual costs associated with the submergence of arable lands.

The objective function is assumed to be a linear function of the decision variables. This means the mathematical model is formulated as a problem of linear programming. The dimensions of the problem include about 100 constraints and 150 variables. The program for running the model on the IIASA PDP 11/70 was prepared by W. Sikorski. All of the calculations were based on preliminary data. Following are some of the results obtained.

The year was divided into seven seasons (December and January, the months when the irrigation system does not work, were excluded): October - November - February - March; April; May; first half of June; second half of June; July; August - September. The basic parameters of the Silistra water supply system are shown in Figure 4a.

The unit cost of water is determined as the additional cost of regional water supply due to the unit increment in water demand for a given irrigated area and season. As seen from Figure 4b, the unit costs of water depend essentially on the geographical location of the irrigated area and the season of water consumption. For example, in the third and fifth time-periods, the unit cost of water varies by a factor of four, depending on the location of irrigated area. Analogously, in the first and fourth areas, the unit cost of water differs almost eightfold, depending on the season. These results mean that, in the Silistra case, the use of the average unit water costs for regional planning is inappropriate.

REFERENCES

1. Texas Water Development Board, 1970,  
"Systems Simulation for Management of  
a Total Water Resource", Report 118.
2. Pleshkov, J.F. "Regulation of Runoff",  
Leningrad, 1972 (in Russian).

A COMPLETE ECONOMIC MODEL  
OF ONE PRODUCT

Nikolai Kolarov

This is a study of a relatively new subject. It concerns possibilities for creation of a theory and modeling of one product or commodity. In the case of economic agents, firms, individuals and social organizations, the product appears as the basic exchange unit. In fact, the product is an important part of most economic activities, including production, marketing, and finance. Here we make an attempt to present the product as an economic complex, an entity with certain properties and functions in the mechanism of interactions. Accordingly, we propose a model of the product. In our belief, such a model will give opportunities of development in two directions: examination of situations which appear with some important products on a regional or worldwide scale, and analysis of one-product or multiproduct firms.

The modeling approach supposes a simultaneous construction of two models of one and the same product. One on a global and the second on a local level (in this case regional level). The necessity of the approach was brought about by a desire for a better understanding of the possibilities for evaluation of any given product in a certain region, in case the global tendency of that product is known. The examination of the region-world

In the theory of the firm and corporate planning modeling, the product appears mostly as a preliminary assumption about the type of organization (single- or multiproduct type). Many theoretical and modeling approaches try to explain organizational behavior and not the behavior of the product. We maintain that the product is not just a shadow factor for the organizational activity, but it is something real, an economic entity in an abstract but existing economic structure. This structure and its behavior is usually classified in terms of organizational attributes. The evolution from the studies of the organization to the studies of the product, is an evolution from structuralism to functionalism on a theoretical level. In spite of the above, we do not reject a clarification of some theoretical errors.

The goal of the investigation is to show the reality of the economic structure of the product as an entity of elements and interactions. The general notion of a product (commodity) is intuitively well understood. Usually, for most of us, the product means a certain combination of utility, quality and price. In our consideration, "the characterizing vector of the product" is significantly enlarged. We propose 18 indicators of the product as an economic entity, which come from three phases of product circulation: production, marketing, and financing. In a broad sense, these indicators of the product state are the following economic phenomena:

<u>Market</u>	<u>Production</u>	<u>Finance</u>
utility	output (V)	revenue (G)
demand (D)	capacity ( $V^C$ )	profit
price (P)	equipment (E)	investment (I)
market promotion (A)	labor (L)	current assets (CA)
inventory (N)	raw materials (M)	borrowing (B)
supply (S)	R and D (R)	
	cost (C)	

Some of those indicators must be treated as product attributes, from a more abstract point of view. For example, capacity as production capacity for a given product or raw

materials as materials included in the product body, and so on. Further, we shall call this characteristic vector of the product, the product's basic economic indicators (PEBI). According to our idea, when the model of the product is to be constructed one structural equation for each PBEI must be built. The system of 18 simultaneous PBEI equations we shall call a "full-range" model of the product. Any study which does not include all elements of this product economic structure must be considered partial.

In the present study, we try to give an additional analysis of the decision variables of the model. Each decision variable has a connection with an additional problem outside the product model and this problem can be interpreted as the "private sphere of activity" in organizational terms. A determination by optimization is a way to obtain most of the decision variables. So the planning decision for all PBEI simultaneously is a two stage procedure which includes:

- Optimization for a relatively autonomous private sphere of activity problems, which give the levels of decision variables of the model.
- Decision on the system of structural equations.

The product approach is made consistent at the planning level by passing from market through production to finance. Balancing the elements of the product economic structure is a continuous process for all stages of the product life cycle from a "new product" to an "obsolete product".

#### THE PRODUCT MODEL

The full-range model of the product, based on the 18 PBEI will be specified for three sectors. Each sector contains several PBEI functions, collected logically or according to common assumptions.

##### *Market Sector*

The behavior of six PBEI is described in this part of the product model, which gives us six structural "market mix"



Product equations. These are: product price function ( $P_f$ ), product utility function ( $U_f$ ), product demand function ( $D_f$ ), product market promotion function ( $A_j$ ), product inventory function ( $N_f$ ), product supply function ( $S_f$ ).

$U_f$ : Utility function

We shall specify the product utility as a function of product attributes by the following equation:

$$U_t = u_1(p) \{u_2 U_{0t} + u_3 Q_t^1 D_t\} \quad (1)$$

where

- $U_t$  = index of the product utility in period  $t$ ;
- $U_{0t}$  = level of the satisfied consumer need by the product in period  $t$ ;
- $Q_t$  = product quality level in period  $t$ ;
- $D_t$  = product demand in period  $t$ ;
- $U(p)$  = consumer choice probability as a degree of preferences of that product among the whole scale of products in the group.

Unlike the traditional view of  $U_f$ , represented by the Marshall deterministic approach and Neuman-Morgenstern stochastic approach, we here try to specify a non-traditional but workable  $U_f$ .

Decision variables:  $U_{0t}, Q_t$ .

$D_f$ : Demand function

A specification of  $D_f$  with all influencing factors in one equation is very complicated. We propose the following log-linear  $D_f$ :

$$D_{ft} = d_0 U_t^{d_1} \left( \frac{y_t}{P_{int}} \right)^{d_2} P_t^{d_3} A_t^{d_1} e^{\phi t} \quad (2)$$

where:

- $d_0$  = parameter for the product market growth [ $d_0 \gtrsim 1$ ];
- $Y_t$  = consumer income in time period  $t$ ;
- $P_{int}$  = index of prices. The  $\left[\frac{Y_t}{P_{int}}\right]$  ratio gives the income impact on demand on current prices base.
- $e^{\phi t}$  = indicator of the seasonal variation [ $\phi$ ] and the process of obsolescence of the product.

$P_f$ : Price function

Product pricing (mark-up dynamics) is a combination of three basic forces: production as a variation of the total manufacturing cost ( $C_t$ ) and its elements; market as a ratio of the product demand and the total product supply ( $\frac{D}{S}$ ) in period  $t$ ; government policy as a long-range level of income tax ( $\kappa$ ). De Menil [1] first offered such a mixed  $P_f$ .

$$P_{ft} = \frac{1}{(1-\kappa e)} \left(\frac{D_t}{S_t}\right)^{P_1} C_t^{P_2} \quad (3)$$

Decision variable:  $\kappa$ .

$A_f$ : Market promotion function

By that function we are trying to explain the problem of "measuring market response to a communications mix" in the product market [Montgomery and Silk (2)].

$$A_t = a_0 + \sum_{i=0}^T a_{i+1} \lg AE_{t-i} + \sum_{i=0}^T a_{i+T+2} \lg SE_{t-i} \quad (4)$$

where:

- $A_t$  = product market share at  $t$  as a part of the regional or world market;
- AE = advertising expenditures;
- SE = service and other market promotion expenditures.

$i = T \dots t$ ,  $T$  - the beginning of existence of the product market.

Explanatory variables  $AE$  and  $SE$  are lagged for historical reasons and are not a current formation of the product market share.

Decision variables:  $AE$ ,  $SE$ .

$N_f$ : Inventory function

The finished good inventory can be explained as a variation around the optimal stock. The total inventory cost ( $C_N$ ) is represented as a function of that variation

$$C_{N_t} = n_1 \phi_1 N_t + n_2 \phi (D_t - V_t - N_t) \quad (5)$$

$C_{N_t}$  = total inventory cost;

$\phi_1$  = per unit cost of the inventory;

$\phi_2$  = per unit cost of losses when the stocks are missing;

$N_t$  = the current inventory  $N_t = N^0 + N'_t$ ,

where  $N^0$  = the optimal inventory and  $N'_t$  = the "over-optimum" level of inventory.

Decision variable:  $N^0$ .

$S_f$ : Supply function

The total product supply ( $S_t$ ) could be expressed as a function of the input-output price ratios,  $P_t/P_{w,m,E}$  :

The whole potential stock of product at  $t[V_t^C + N_t]$  and the product demand ( $D_t$ ),

$$S_t = S_0 + S_1 \left( \frac{P_t}{P_{w,m,E}} \right) + S_2 (V_t^C + N_t) + S_3 D_t \quad (6)$$

where

$P_{w,m,E}$  = index of the input prices: prices of materials,  
wages and depreciation rates;  
 $V_t^C$  = production capacity at t.

*Production Sector*

The product manufacturing process gives the product characteristics for seven PBEI. The product structure could be described by seven equations: the production function  $[V_f]$ , the production capacity function  $[V_f^C]$ , the equipment function  $[E_f]$ , the labor function  $[L_f]$ , the raw materials function  $[M_f]$ , the technical progress function  $[R_f]$  and the cost function  $[C_f]$ .

$V_f$ : Production function

We use a four-factor disaggregated  $V_f$ , specified on an empirical base.

$$V_{ft} = v_1 E_t^{v_2} L_t^{v_3} M_t^{v_4} R_t^{v_5} \quad (7)$$

where:

- $R_t$  = the level of disembodied technical progress in period t;
- $V_{ft}$  = product output in physical units in period t;
- $E_t$  = equipment in physical units in period t;
- $L_t$  = labor in man-hours in period t;
- $M_t$  = raw materials in physical units in period t.

The elasticities can be obtained from  $V_f$  for the needs of input factors E, L, M, R.

V<sub>f</sub><sup>C</sup>: Capacity function

The capacity is usually defined in two ways: (i) as the maximum load of production equipment; (ii) as maximum output with minimum total average cost. We shall simplify the first definition of the capacity as the normal level of output given by an appropriate labor/equipment combination accounting for the investments in new equipment (Hall's putty-clay models).

$$V_t^C(E_v^i, t) = \rho_0 L \left( \sum_{i=t-1}^{T_v} E_v^i \right) / (E_v t) \quad (8)$$

where:

$V_t^C$  = normal level of output at  $t$  produced by all models [ $V^i$ ] of equipment  $E(i - t, \dots, T_v)$  and  
 $T_v$  = age of the oldest model (generation) of equipment;

$L \left( \sum_{i=t-1}^{T_v} E_v^i \right)$  = labor employment deduced from the normal labor/equipment ratio;

$/(E_v t)$  = investment in new equipment of year  $t$ .

E<sub>f</sub>: Equipment function

The  $E_f$  equation represents the balance of equipment in terms of past value, depreciation, and investment in new equipment.

$$\sum_{i=t}^{T_v} E_v^i, t = e_0 + e_1 \sum_{i=t-1}^{T_v} E_v^i - e_2 \sum_{i=t-1}^{T_v} \theta_v^i E_v^i + e_3 / (E_v t) \quad (9)$$

where

$\sum_{i=t}^{T_v} E_{v^i, t}$  = average stock of equipment and plant of all generations available at the beginning of period t;

$\theta = [\theta_{v^i}]$  = vector of the depreciation rates for all  $v^i$ .

Decision variable: vector  $\theta$ .

$L_f$ : Labor function

The labor function included in the product manufacturing process can be obtained by the equation:

$$L_t = l_0 [WL(\sum_{i=t}^{T_v} E_{v^i})]^{l_1} V_t^{l_2}, \quad (10)$$

where:

$L_t$  = labor in man-hours,

$W = \{W_i\}$  = vector of all wages.

In this way, labor is a function of all principal labor costs determined by the product of the wage vector and full capacity need for labor for a given output at t.

Decision variable: vector  $W$ .

$M_f$ : Raw materials function

The needed (product) raw materials could be obtained from:

$$M_t = m_0 + m_j \sum_{j=1}^q P_{Mj} K_{Mj} V_t, \quad (11)$$

where:

- $j = 1, 2, \dots, Q$  ;  $Q$  is the number of materials included in the product body;
- $P_m = \{P_{Mj}\}$  = vector of material prices
- $K_m = \{K_{Mj}\}$  = vector of technological coefficients for the material expenditures taken as a column from a given multiproduct input-output model.

The money value of needed materials  $\{M_t\}$  for the given product output  $\{V_t\}$  is a combination of all material needs of a technological specification and some possibilities for material substitution.

Decision variable: vector  $K_M$

$R_f$ " Technical progress function

The disembodied technical progress measured by the product level of technology according to CHEN [3] can be given by the following equation:

$$R_t = R_0 e^{r_1 t} z_t^{r_2} \tag{12}$$

where:

- $R_t$  = level of product technology in time period  $t$ ;
- $R_0$  = initial level of technology;
- $r_1$  = exponential rate of exogenous technical progress;
- $X_t$  = index of experiences which can be expressed empirically by the cumulated output or cumulated investments;
- $r_2$  = learning coefficient.

$C_f$ : Cost function

Total manufacturing cost is calculated from the following equation:

$$C_t = c_0 + \theta_e^{c_1} E_t^{c_2} + w_e^{c_3} L_t^{c_4} + P_{M_e}^{c_5} \left( \frac{\sum_j K_{Mj} V_t}{V_t} \right)^{c_6} + C_{vi}^{c_7} + C_A^{c_8} \quad (13)$$

where:

$C_t$  = total manufacturing cost per unit by given output;

$\theta_e, w_e, P_{M_e}$  = average depreciation rate, wage rate, and price of materials rate;

$E_t, L_t, \frac{\sum_j K_{Mj} V_t}{V_t}$  = all input volumes in physical units per unit of given output;

$C_{Ivt}$  = cost of investment for a piece of new equipment;

$C_A$  = all additional expenditures.

*Financial Sector*

The product financial structure, part of a product economic structure, is represented as the financial flows among five financial PBEI. The five PBEI financial structure equations are the following: the revenue function  $[G_f]$ , the profit functions  $[\Pi_f]$ , the investment function  $[I_f]$  the current assets function  $[CA_f]$ , the money borrowing function  $[B_f]$ .

$G_f$ : Revenue function

In a statistical sense, the revenue (total income) obtained from the product sales for the period  $t$  is linearly influenced by product supply  $[S_t]$ , demand  $[D_t]$ , price  $[P_t]$ , and the one-period-lagged revenue  $[G_{t-1}]$ .

$$G_t = g_0 + g_1 S_t + g_2 D_t + g_3 P_t + g_4 G_{t-1} \quad (14)$$



$\Pi_f$ : Profit function

The two aspects of profit circulation are, profit creation and profit distribution. Thus we have two profit equations:

-- Pretax profit obtained in time period t:

$$\Pi_t = G_t - \left( \sum_{i=t}^{T_v} \theta_v^i E_v^i + W_i L_{i,t} + M_t + Z_t + C_A \right) ; \quad (15)$$

-- Profit distribution among all involved in the production net income generation:

$$\lambda_1 TAX_t + \lambda_2 DEBT_t + \lambda_3 IF_t + \lambda_4 CA_t + \lambda_5 WSD_t = \Pi_t ; \quad (16)$$

where:

- $TAX_t$  = taxation in time period t,  $\lambda_1$  = profit tax rate;
- $DEBT_t$  = total debts;
- $CA_t$  = internally generated current assets for raw materials and product inventory;
- $WSD_t$  = additional wages, salaries and dividend payments

$I_f$ : Investment function

We shall describe the capital budgeting process in two stages:

-- The decisions in time period t for new equipment including plant in physical volume, obtained from the following equation:

$$\Delta E_{t+\tau} = f_0 \lg \left( \frac{\Pi}{(1+f_1)^{\mu_1} \theta_v^i \sum_i E_v^i(t)} \right) \quad (17)$$

where:

$\Delta E_{t+\tau}$  = new equipment decision in time period  $t$  with investment lag;

$\mu_1$  = rate of return of the borrowing money;

$f_0, f_1$  = positive constants.

From equation (17) it follows that the geometrical rate of growth of the product equipment increases with the increase of the ratio  $\Pi_t / \theta \sum_i^v E_{v,i,t}$  - the rate of return of existing equipment, and by the decrease of  $\mu_1$  - the rate of return of credit money. The  $(1 + f_1)\mu_1$  part of the equation reflects the rate of return  $\mu_2$ , which is necessary for maintenance of the existing equipment.

If  $(1 + f_1)\mu_1 < \mu_2$ ,  $\Delta E_{t+\tau}$  will be negative and if  $(1 + f_1)\mu_1 > \mu_2$ ,  $\Delta E_{t+\tau}$  will be positive.

-- When  $\Delta E_{t+\tau}$  is known,  $I_t$  -- the investment as money equivalence of  $\Delta E_{t+\tau}$  -- can be calculated. Investments ( $I_f$ ) will be obtained from two sources:

a) from internally generated and accumulated capital investment funds [ $IF_t^A$ ]

$$IF_t^A = IF_{t-1}^A + \lambda_3 \Pi_t + \theta \sum_i^v E_{v,i,t} \quad , \quad (18)$$

where:

$IF_{t=1}^A$  = remaining capital funds from past periods;

$\lambda_3 \Pi_t$  = the profit determined for investment in time period  $t$ ;

$\theta \sum_i^v E_{v,i,t}$  = total depreciation for investment in time period  $t$ ;

b)  $B_1$  = borrowing for capital investment.

The investment function ( $I_f$ ) can be described in the following way:

$$I_t (\Delta E_v^{t+\tau}) = z_0 + z_1 (IF_t^A) + z_2 B_{1t} \quad (19)$$

Equation (19) calculates the necessary money for new equipment as a statistical function of internally generated capital funds  $[IF_t]$  and bank loans  $[B_{1t}]$ .

Decision variable:  $B_{1t}$

CA<sub>f</sub>: Current assets function

The amount of money necessary for the service of the product reproduction cycle depends on inventory volumes and available cash.

$$CA_t = y_1 + y_2 M_t + y_3 C_{Nt} + y_4 CASH_t + y_5 B_{2t} \quad , \quad (20)$$

where

$CA_t$  = all necessary current assets in time period  $t$ ;

$B_{2t}$  = credits in current assets;

$CASH_t$  = cash funds

Decision variables  $B_{2t}$  and  $CASH$

B<sub>f</sub>: Money borrowing and government spending function

The last equation in the product model represents the level of outside capital needs for normal product reproduction. There are two types of outside money: borrowing money ( $B_1, B_2$ ) and governmental financial aids  $[GA]$ , if normal circulation is impeded.

$$B_t = \beta_0 + \beta_1 B_{1t} + \beta_2 B_{2t} + \beta_3 DEBT + \beta_A GA_t \quad , \quad (21)$$

where:

$B_t$  = all outside money needed in time period  $t$ ;

$DEBT$  = all debts at  $t$ .

The product model interactions among all PBEI including some exogenous variables can be seen in Figure 1.

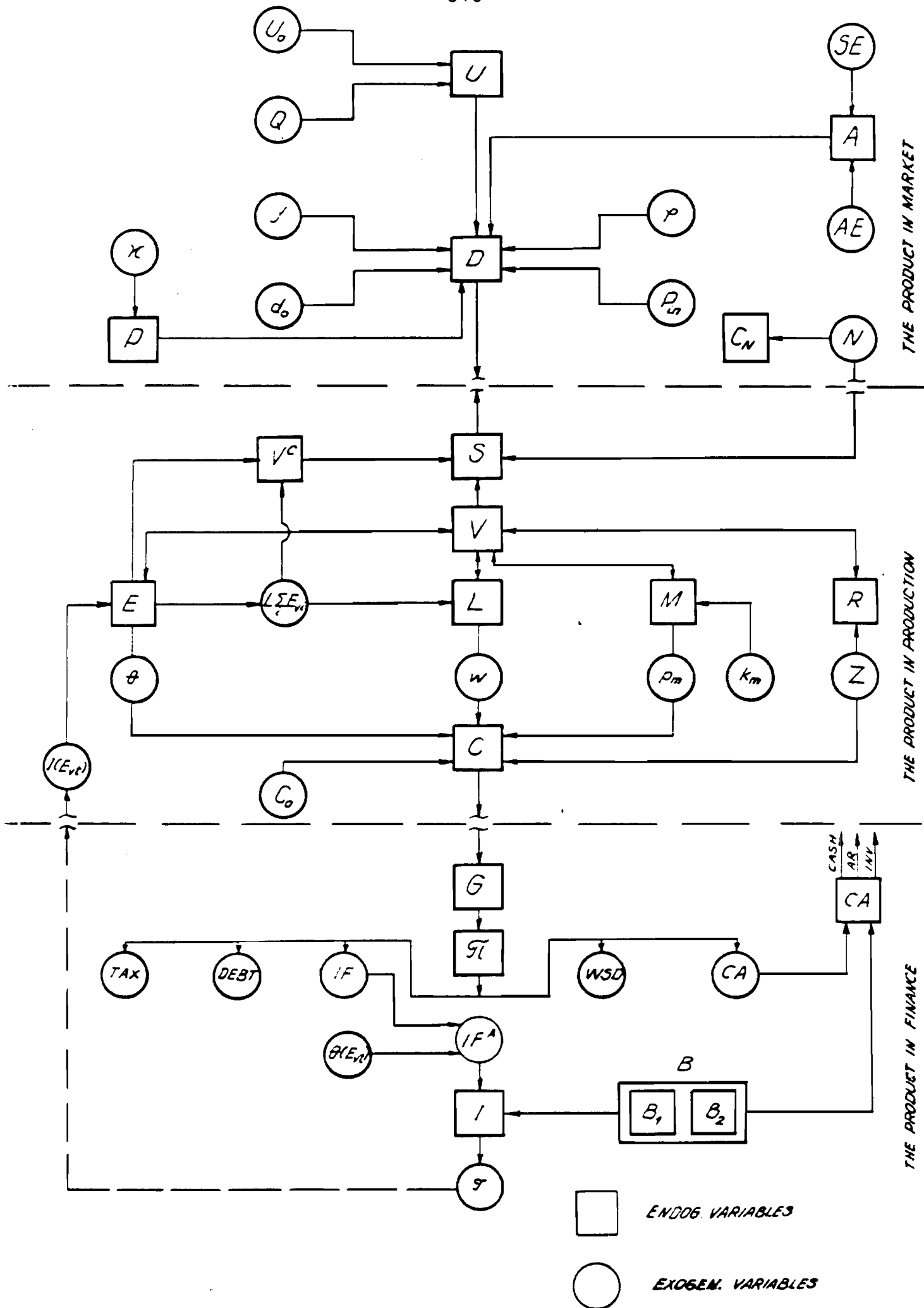

Figure 1. The product model interactions.

DECISION VARIABLES DETERMINATION APPROACH

$U_{0t}$ : The Level of Satisfaction of  
Consumer Need for the Product

This variable is obtained if the description of the ultimate consumer need is given (see Ebert and Thomas [4]). That means a chain of descriptions of all possible consumption attributes of the product. For the purpose of qualification of  $U_0$  the consumer function of the product must be decomposed into main components with loading of every component as a part of the whole consumer function of a given product. (For example see Table 1.)

If the new product, in our case a washing machine, satisfies the consumer need at different levels,  $U_0$  will vary between 0.1 and 1.

Table 1. Consumer need: washing.

	I	II	III	IV	V
Components	Rubbing	Water changing	Wringing	Drying	Ironing
Loading coefficient	0.3	0.1	0.2	0.2	0.2

$Q_t$ : The Product Quality Level at  $t$

To determinate  $Q_t$ , we need an introduction of several levels of the product standard quality (super, I, II, III, etc.). The choice of the quality level will depend on:

- the marginal cost of the quality  $[\frac{\partial C}{\partial Q}]$  ,
- the marginal demand for the quality  $[\frac{\partial D}{\partial Q}]$  ,
- the marginal price of the quality  $[\frac{\partial P}{\partial Q}]$  .

The choice of the level of  $Q_t$  at a given quality level scale can be obtained as a result of the analysis of elasticities when  $\Delta C$ ,  $\Delta D$ ,  $\Delta P$  are known at  $t$ .

$\kappa$ : Income Tax Rate

The determination of the optimal tax rate is a tool for market equilibrium and creation of necessary conditions for a normal product reproduction cycle. The income cannot be increased above a certain critical level of the remaining income, necessary for a normal self-financing of the product. The optimal tax rate  $[\kappa]$  will be determined by a given elasticity of the demand-price elasticity  $[\epsilon_{D/p}]$  and the supply-price elasticity  $[\epsilon_{S/p}]$ . The total amount of the income tax (IT), obtained on a given income tax rate will be the following:

$$VP - V(P - \kappa^c) = IT \quad , \quad (22)$$

where:

$$\frac{dIT}{dV} = 0 \quad \text{or} \quad (V \frac{dP}{dV} + P) - [V \frac{d(P - \kappa^e)}{dV} + (P - \kappa^e)] = 0 \quad .$$

After some transformations the expression will be:

$$P(1 - \frac{1}{\epsilon_{D/p}}) - (P - \kappa^e)(1 + \frac{1}{\epsilon_{S/p}}) = 0 \quad . \quad (23)$$

From here

$$\kappa = P - \frac{P(1 - 1/\epsilon_{D/P})}{(1 + 1/\epsilon_{S/P})} \quad (24)$$

To determine

$$\kappa, \quad P = P_{t-1} \quad .$$

*Advertisizing Expenditures (AE), Service  
and Other Market Expenditures (SE)*

If the profitability of all market expenditures [ $\mu_A$ ] is

$$\mu_A = \frac{PdV}{dA} \quad , \quad (25)$$

and the elasticity of market expenditures with respect to the demand [ $\epsilon_{A/D}$ ] is given, optimum  $A_t$ , where  $A_t = [AE_t + SE_t]$  can be reached when

$$A_c = P \left( 1 - \frac{1}{\frac{PdV}{dA_t}} \right) \text{ or } A_c = P \left( 1 - \frac{1}{\mu_A} \right) \quad , \quad (26)$$

where

$A_c$  = marginal value of A.

$A_c$  is divided on AE and SE at t according to the ratio,

$$\frac{\sum_{i=0}^T a_{i+1}}{T} \Bigg/ \frac{\sum_{i=0}^T a_{i+T+2}}{T}$$

which means a ratio of the average coefficients of AE and SE in equation (4).

*Optimal Inventory ( $N^0$ )*

The optimal inventory problem for a one-product inventory line is usually described in terms of a safety stock, a penalizing cost for the stocks over use, different time intervals of having or missing a stock, and so on. The adaptation of an appropriate optimal inventory model for determination of  $N^0$  is not a complicated problem.

*Optimal Depreciation Rate for All Vintages of Equipment (Vector  $\theta$ )*

The optimal depreciation rate  $[\theta_{v,i}]$  for each working piece of capital equipment by year of model  $[V^i]$  could be calculated for a given time period of the  $V^i$  economic life  $[n_{v,i}]$ , assuming steady wear of each  $V^i$  in the following way:

$$\theta_{v,i} = \frac{C_{v,i}}{n_{v,i}} 100\% \quad . \quad (27)$$

The time period  $n_{v,i}$  will be calculated as a time during which  $H_{v,i}$ , the profit obtained as a result of  $V^i$ , must be at a maximum:

$$\Pi_{v,i} = \int_0^n [G_{v,t} - C_{v,i}]^{-pt} + C_{v,i}(n)^{-pn} - C_{v,i} \quad , \quad (28)$$

where:

$G_{v,t}$  = revenue from  $V^i$  in time period  $t$ ;

$C_{v,t}$  =  $V^i$  in time period  $t$ ;

$C_{v,i}(n)$  = remaining cost at the end of the economic life of  $V^i$ ;

$C_{v,i}$  = cost of  $V^i$  at the beginning of use of  $V^i$ ;

$n_{v,i}$  = the optimal economic life of each  $V^i$  is determined on the maximum level of the profit.



*The Wage Rate Level (Vector W)*

The vector W is calculated according to "the factors of wage rate determination" (TACHIBANAKI [5]). The influencing factors are average wage level in the region (industry) [ $\alpha$ ], special conditions [ $\beta$ ], sex [ $j$ ], occupation [ $\delta$ ], size of the organization [ $\nu$ ], education [ $\gamma$ ], experiences of the workers [ $\theta$ ], working hours [ $h$ ]. The level of each factor will be indicated by a symbol:  $l_4, l_5, l_6, l_7, l_8, l_9, l_{10}, l_{11}$ . The effect of interactions among the factors is represented by the combinations:  $(\alpha\beta), (\alpha j), (\alpha\beta j) \dots$ . The determination of each element of vector W can be achieved by the following equation:

$$\begin{aligned}
 W_{l_4, l_5, \dots, l_{11}, h} = & \alpha_{l_4} + \beta_{l_5} + j_{l_6} + \delta_{l_7} + \nu_{l_8} \\
 & + \dots + (\alpha\beta)_{l_4, l_5} + (\alpha j)_{l_4, l_5}, \\
 & + \dots (\alpha\beta\gamma)_{l_4, l_5, l_6}, \\
 & + \dots + (\alpha\beta j \delta)_{l_4, l_5, l_6, l_7}, \dots
 \end{aligned}
 \tag{29}$$

where:

$W_{l_4, l_5, \dots, l_{11}, h}$  denotes the wage earning per hour for a person of type h in cell " $l_4, l_5, l_6, l_7, l_8, l_9, l_{10}, l_{11} \dots l_h$ ".

$K_m$ : Vector of Technological Coefficients  
for All Product Raw Material Inputs

Basically,  $K_m$  is determined statistically as a raw column of the product in a multiproduct input-output model. The possibilities for a substitution of materials in the product body can be taken from a production function constructed on a disaggregated level.

*The Capital Investment Borrowing* [ $B_{1t}$ ]

The optimal level of the credit can be determined as a ratio of the borrowing money to the whole capital  $B_1/K^T$  at  $t$ . That can be done by a preliminary analysis of some interrelations, given by the equation:

$$\mu_2 = \mu_0 + \frac{B^T}{K^T} (\mu_0 - \lambda_2) \quad , \quad (30)$$

where:

$\mu_2$  = rate of return of own capital;

$\mu_0$  = rate of return of the whole capital;

$\lambda_2$  = bank rate;

$B^T$  = total accumulated borrowing money in time period  $t$ ;

$K^T$  = total capital.

$B_t$  is the maximum credit, given on the basis of maximum capital.

APPENDIX: Input-output Specifications of the Product Model

OUTPUT

- (PBEI)
- Utility (U)
  - Demand (D)
  - Price (P)
  - Market share (A)
  - Inventory (N)
  - Supply (S)
  - Output (V)
  - Capacity ( $V^C$ )
  - Equipment (E)
  - Labor (L)
  - Raw materials (M)
  - R and D (R)
  - Costs (C)
  - Revenue (G)
  - Current assets (CA)
  - Profit (H)

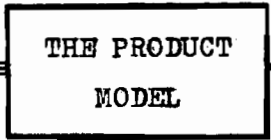

INPUT

- Level of satisfaction ultimate consumer need by the product ( $U_0$ )
- Product quality level (Q)
- Income tax rate ( $\kappa$ )
- Market promotion expenditures (AE, SE)
- Optimal finished good inventory ( $N^0$ )
- Vector  $\theta$  (depreciation rates)
- Vector W (wage rates)
- Vector  $K_m$  (technological coefficients)
- Vector  $P_m$  (input prices of materials)
- Investment loans ( $B_I$ )
- Current assets loans ( $B_2$ )
- Initial level of technology ( $R_0$ )
- The rate of return ( $\mu_2$ )
- Government spendings (GA)
- Cash funds (CASH)
- Total debts (DEBT)
- New equipment decisions in physical units ( $\Delta E_{t+\tau}$ )
- Total investment funds ( $IF_A$ )
- Age of the oldest generation of equipment available (TV)
- Income index of consumers (Y)

REFERENCES

- Chen, E. (1976) The empirical relevance of the endogenous technical progress function. *Kyklos* 29(2).
- De Menil, G. (1974) Aggregate price dynamics. *The Review of Economics and Statistics* VI(2).
- Ebert, H., and C. Thomas (1971) *Gebrauchwert-Kosten-Analyse*. Berlin: V. Die Wirtschaft.
- Montgomery, D., and A. Silk (1972) Estimating dynamic effects of market communications expenditures. *Management Science* 18(10).
- Pindyck, R (1977) Cartel pricing and the structure of the world bauxite market. *The Bell Journal of Economics* 8(2).
- Tachibanaki, T. (1975) Wage determination in Japanese manufacturing industries: structural change and age differentiation. *International Economic Review* 16(3).

PART IV

LIST OF PARTICIPANTS

Dr. Atanas ATANASSOV  
Complex Research Design  
Institute for Territorial  
Development, Urbanization  
and Architecture  
Rakovski 134  
Sofia, Bulgaria

Dr. Gyula BORA  
Deputy Head of the  
Faculty of Commerce  
University of Economics  
Karl Marx  
1093 Budapest  
Dimitrov ter 8  
Hungary

Prof. Emil CHRISTOV  
Head of the Council for  
Social Management  
bul. Dondoukov 2  
Sofia, Bulgaria

Dr. Krassimir EVTIMOV  
Committee for Architecture  
and Urbanization  
bul. Dondoukov 2  
Sofia, Bulgaria

Dr. Gavril GAVRILOV  
Institute for Social  
Management  
Pionerski Put 21  
Sofia, Bulgaria

Dr. Nicolai GRIGOROV  
Institute of Regional  
Planning and Development  
KNIPITUGA  
Rakovski 134  
Sofia, Bulgaria

Dr. Iliya GOUEVSKY  
Institute for Engineering  
Cybernetics  
Bulgarian Academy of Science  
Block IV  
Sofia, 1113, Bulgaria

Dr. Michal INKIELMAN  
Systems Research Institute  
Newelska 6  
01-447 Warszawa, Poland

Dr. Nicolai KOLAROV  
Institute for Social  
Management  
Pionerski Put 21  
Sofia, Bulgaria

Dimiter MIHAILOV  
Chairman of the County  
People's Council  
Silistra, Bulgaria

Prof. Nicola NAUMOV  
Karl Marx University  
Rakovski 114  
Sofia, Bulgaria

Dr. Ognian PANOV  
Institute for Social  
Management  
Pionerski Put 21  
Sofia, Bulgaria

Ms. Diana RADOEVA  
The National Committee for  
Applied Systems Analysis  
and Management  
Slavyanska 8  
Sofia, Bulgaria

Prof. Czeslaw SOMOROWSKI  
Director  
Instytut Melioracji i  
Uzytkow Zielonyeh  
Falenty K. Warszawy  
05-550 Raszyn  
Warszawa, Poland