

NOT FOR QUOTATION
WITHOUT PERMISSION
OF THE AUTHOR

THE ECONOMIC IMPACT OF NUCLEAR POWER
DISCONTINUATION IN SWEDEN

Lars Bergman

May 1980
WP-80-97

Working Papers are interim reports on work of the International Institute for Applied Systems Analysis and have received only limited review. Views or opinions expressed herein do not necessarily represent those of the Institute or of its National Member Organizations.

INTERNATIONAL INSTITUTE FOR APPLIED SYSTEMS ANALYSIS
A-2361 Laxenburg, Austria

PREFACE

Prior to the referendum in March 1980 on the future use of nuclear power in Sweden, a committee appointed by the Swedish government investigated the economic and social consequences of a discontinuation of the Swedish nuclear power program. The committee should not make any recommendations on ranking of various alternatives. Thus, its main task was to elucidate the economic and social impact of a nuclear power discontinuation, and to provide the electorate with estimates of various "costs" associated with such a policy.

The author was asked by the committee to carry out an analysis of the long term economic consequences of a discontinuation of the Swedish nuclear power program. The committee was primarily concerned with two aspects of such a policy; one was to estimate the value for the society as a whole of the resources already invested in nuclear power plants; the second was to evaluate how the loss of that value would affect the development of the economy, particularly in terms of the sectoral and regional allocation of the labor force.

It was an explicit request by the committee that the analysis should be based on simulation with a general equilibrium model of the Swedish economy, previously developed at IIASA by the author, in cooperation with A. Por. This report presents the methodology and results of the analysis carried out for the committee.

The characteristic feature of a general equilibrium model is that both quantities and prices are determined within the model. Thus, the model can simulate future states of the economy where supply equals demand on all commodity and factor markets at prices, wages and interest rates such that all producing

sectors can cover their costs and no sector makes excess profits. The general equilibrium model used in this study is elaborated particularly in terms of the treatment of energy demand and foreign trade. The need for the first elaboration in this context is obvious. The second is motivated by the relatively large foreign trade sector in the Swedish economy, and the fact that Sweden, to some extent, has specialized in relatively electricity-intensive export industries.

Several different alternatives for a discontinuation of the Swedish nuclear power plants before 1990 were investigated. In one case, the replacement of the nuclear plants by other power plants was emphasized. In two other cases, electricity conservation efforts in various parts of the economy were emphasized. However, no attempt was made to identify the cost-minimizing mix of replacement and conservation investments.

The results of the model simulations indicate that a discontinuation of all nuclear power plants in Sweden before 1990 would lead to a loss in terms of potential household consumption of goods and services. Thus, in the discontinuation cases, the level of potential household consumption around 1990 was 2-3% lower than in the "reference case". The estimated present value of the total reduction of potential household consumption 1980-2000, was 70.10^9 - 110.10^9 Skr. in 1979 prices. On the sectoral level, there was a negative impact on production and employment in the electricity intensive sectors, primarily the paper and pulp industry.

Clearly there are many uncertainties in impact estimates of this type. A number of sensitivity tests of the results were carried out in order to get a rough measure of the uncertainty. It then turned out that the assumptions about future oil prices and the substitutability of electricity and other factors of production were the most strategic ones. Apart from the uncertainties about key parameters and exogenous variables, there is also a systematic under-estimation of the impact of the investigation policy inherent in the methodological approach. The reason for this is that when that impact is calculated as a difference between equilibrium allocations, various kinds of adjustment costs are, by definition, neglected. However, it seems reasonable to conclude that these neglected costs are quantitatively less important than the costs taken into account.

ACKNOWLEDGEMENTS

The author is grateful to Andras Por at IIASA for his work in connection with the transfer of the model used in the study from IIASA to the Stockholm School of Economics, and to Stefan Lundgren at the Stockholm School of Economics, who implemented the necessary modifications of the model and who has made several valuable comments on earlier drafts of this report. Karl-Göran Måler at the Stockholm School of Economics and Alf Carling at the Swedish National Industrial Board also made valuable comments on earlier drafts.

THE ECONOMIC IMPACT OF NUCLEAR POWER
DISCONTINUATION IN SWEDEN

Lars Bergman

1. Background and Purpose of the Study

As a consequence of the accident in the nuclear plant at Three Mile Island, U.S.A., the Swedish Parliament decided to arrange a referendum on March 23, 1980, on the future use of nuclear power in Sweden^{1/}. The basic issue in the referendum would be whether the nuclear plants now in operation should be closed down or used over their full life-time, together with the plants not yet in operation and those under construction. As is always the case in Sweden, the result of the referendum is only an advice to Parliament, which makes the final decision. In this case, however, all political parties represented in Parliament have declared that they will act in accordance with the result of the referendum.

In order to elucidate the economic and social consequences of a discontinuation of the Swedish nuclear power program, a temporary committee was set up by the Ministry of Industry in June, 1979. The task of the committee was limited to the "cost" side of a nuclear power discontinuation, and it should not make

1/ This report was completed before the referendum was held.

any recommendation or ranking of various alternatives. Thus it was left to the electorate to make the more controversial evaluation of the benefits connected with a nuclear power discontinuation, and to compare the costs and the benefits.

The author was asked by the committee to carry out an analysis of the long term economic consequences of a nuclear power discontinuation in Sweden. It was an explicit request that the analysis should be based on simulations with a general equilibrium model of the Swedish economy previously developed at IIASA ^{1/}. The purpose of this report is to present the methodology and results of that analysis ^{2/}.

2. Nuclear power in Sweden and the alternatives in the referendum.

The first nuclear power reactor for commercial generation of electricity in Sweden was taken into operation in 1972. At that time the use of nuclear power was expected to increase rapidly in the future. One reason for this was that further expansion of the use of hydro power was restricted by environmental concerns. Another reason was that the demand for electricity was expected to grow at a fast rate, primarily because of the anticipated increase of electric heating. The use of electricity for heating purposes was stimulated in various ways, reflecting the ambition to reduce Sweden's dependence on imported oil.

The nuclear program has been considerably delayed, partly because of a very strong opposition against the use of nuclear power, partly because of a much slower growth of electricity demand than expected. Thus, according to a prediction made by the power industry ^{3/} in 1972, the demand for electricity in 1985

1/ Bergman, L., and A. Por, A Quantitative General Equilibrium Model of the Swedish Economy, WP-80-4, IIASA, Laxenburg.

2/ The final report to the committee was written in Swedish and published (as Chapter 3) in "Samhällsekonomiska konsekvenser av en kärnkraftsavveckling", DS I 1979:12, Ministry of Industry, Stockholm, 1979.

3/ The prediction was published in "Den svenska kraftförsörjningen fram till 1990", CDL, Stockholm, 1972.

will be 178 TWh, while the most recent prediction for that year is 105 TWh.

As a consequence, the number of nuclear reactors presently in operation is only 6, instead of 14 as anticipated in the power industry forecast mentioned above. In 1978, these nuclear plants generated 23 TWh electricity, corresponding to approximately 25% of total electricity generated in Sweden that year. In addition to the six reactors in operation, two more have been completed but not yet taken into operation, and a further two are almost completed. Thus, if the necessary permissions are given, ten reactors can be in operation before 1982. Two additional reactors are under construction, and can be completed and taken into operation before 1985.

According to a government proposal, prepared just prior to the accident at Three Mile Island, all twelve reactors should be used over their full lifetime. However, no new nuclear power plants should be constructed. Thus, provided the most recent electricity demand predictions are realized, the government proposal implies that the share of electricity generated in nuclear plants will increase and reach a maximum 45-50% around 1987, and then gradually decline as demand grows and the twelve nuclear reactors phase out.

In the referendum, there are three alternatives for the future use of nuclear power in Sweden. One alternative, formulated by those opposing the use of nuclear power, implies that the six reactors now in operation will be closed down between 1985 and 1990. Since this is regarded as the "no-alternative", it seems to be a fairly general agreement that an immediate discontinuation of the nuclear plants would lead to unacceptable costs.

The other two alternatives, formulated by the social-democratic party together with the liberal party and the conservative party, both imply that the six reactors which are completed or under construction, will be taken into operation and used together with those already in operation over their full lifetime. Moreover, both these alternatives imply that no additional plants will be constructed

in the future. Thus, these two alternatives do not differ in terms of the issues which are basic in the referendum. Instead, the differences have to do with the degree of public ownership of the nuclear plants as well as some issues related to energy policy in general.

To sum up, all three alternatives in the referendum imply that nuclear power will be phased out from the Swedish energy supply system before 2010. The referendum concerns the rate at which nuclear power will be phased out; over a 10-year period or over a 25 to 30-year period. Consequently, it is not possible to vote for a continuing and increasing use of nuclear power in Sweden.

At the time when the temporary committee mentioned above was set up, these alternatives were not yet formulated. Thus, the committee had to investigate several alternatives for a nuclear power discontinuation, and to compare these alternatives with a "reference case" where nuclear power policy, as well as energy policy in general, was carried out in accordance with the above mentioned government proposal. None of the alternatives actually investigated by the committee corresponds exactly to any of the three alternatives in the referendum. However, all of the discontinuation alternatives investigated imply that the existing nuclear reactors will be phased out between 1985 and 1990, which is the basic proposal by the so-called "no-side".

3. The problem to be analyzed and the adopted methodology

From the committee's point of view, the basic problem was to estimate the value, for the society as a whole, of the resources already invested in nuclear power plants, and to evaluate how the loss of that value affects society. In this section some general aspects of that problem are discussed, together with the methodological approach adopted in the study. However, as it was stated from the beginning that the above mentioned general equilibrium model of the Swedish economy would be used in this part of the committee's work, the methodological issues are *how* the model should be used, rather than *if* it should be used.

The resources already invested in nuclear plants cannot be reallocated to other uses. These resources represent a sunk cost unless the plants are used for the generation of electricity^{1/}. Thus, from the society's point of view, the cost of producing electricity in the already completed plants is only the running cost. In the plants still under construction, the corresponding cost is the sum of the remaining investment costs, on a per-unit-of-output basis, and the running costs. The owners of the nuclear plants may not be satisfied with prices equal to running costs, but from the society's point of view, that is an income distribution problem rather than a problem related to real production costs.

The value for the society of a resource that can be used for electricity production depends on the cost of producing electricity in other ways and the cost of reducing the use of electricity. Thus, if it is decided that the nuclear power plants will not be used, basically three strategies can be adopted. One is to replace the nuclear plants with other kinds of electricity generation capacity; another is to convert from electricity to other kinds of energy and the third is to reduce electricity consumption by means of conservation measures or through changes in consumption patterns. If the cost for any combination of those strategies is higher than the cost for completing and utilizing the twelve nuclear reactors, the discontinuation represents a cost to the society. That cost, however, is minimized if replacement, conversion and conservation investments are "mixed" so that they are, on the margin, equally profitable.

The problem can be illustrated by Figure 1 below. It applies to the situation in one year during the period 1980-2010, although it illustrates the principles rather than the exact proportions. All cost items are in present value terms. The curve MC_n represents the present value of the marginal cost of electricity produced in nuclear plants. The first segment represents the running costs in already completed plants, while

1/ Or rather energy, since the cooling water in the nuclear plants can, and will in the case of a "yes" in the referendum, be used as an energy source in district heating systems.

the second represents the present value of the sum of remaining investment costs, on a per unit of output basis, and running costs in not yet completed nuclear plants. The total annual electricity production capacity in all the nuclear plants is ac TWh.

The curve MC_r is the present value of the marginal cost of electricity produced in other existing plants, or in plants which can be built in order to replace the nuclear plants. Since the latter do not exist at the present time, the marginal cost of that electricity contains all the relevant investment costs as well as running costs. The curve $MC_c^{1/}$ represents the present value of the marginal cost of reducing the use of electricity. That is, the marginal cost, on a per unit of electricity basis, of conservation and conversion measures. Obviously the curve MC_c is simply the demand curve for electricity, and Figure 1 depicts a segment of the electricity market.

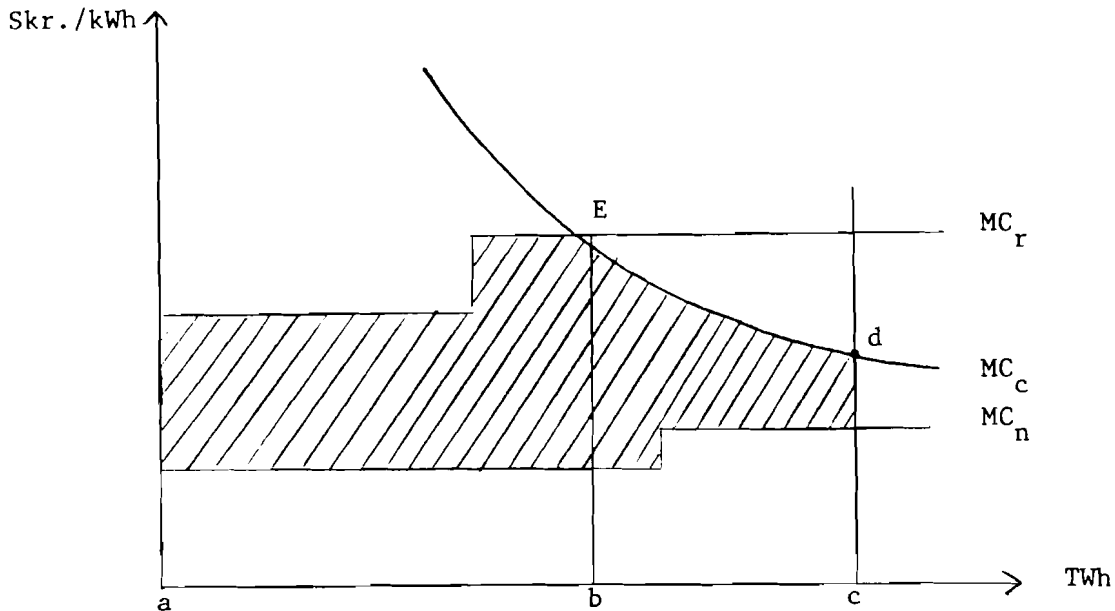

Figure 1.

1/ Since the curve MC_c represents a large number of conservation and conversion measures, each of which is quantitatively rather unimportant, it is reasonable to draw it as a continuous curve without jumps.

At the point E, where MC_r and MC_c intersect, the annual cost of closing down the nuclear plants is minimized. Thus, the minimum cost is attained if the annual nuclear power capacity ab is replaced by other electricity production capacity, while the capacity bc is compensated for by conservation and conversion measures. The annual cost is then equal to the shaded area in Figure 1, and the total cost is equal to the sum of all the annual costs.

During the initial years of the period 1980-2010, the distance ac is approximately 23 TWh, but after 1985, when the not yet completed plants can be taken into operation, it is 55-58 TWh. On the first segment MC_n is estimated to be 0.05-0.07 SKr/kWh,^{1/} while the corresponding figure for the second segment is 0.08-0.10 SKr/kWh.

Both MC_r and MC_c are likely to be steeper during the initial part of the period than during the later part. In the case of MC_r this is because it takes a considerable time to build a new power plant^{2/}. Accordingly, most of the electricity represented by ab in Figure 1 has to be produced in existing oil-fired plants where running costs are very high. Later on, however, "replacement" production can be carried out at a lower cost in new coal fired plants. To some extent the cooling water in these plants can be used as an energy source for district heating systems, which, of course, reduces the cost of electricity.

The running costs in existing oil-fired plants are estimated to be 0.20-0.22 SKr/kWh, while the total (capital plus running) cost in coal fired plants is estimated to be 0.15-0.16 SKr/kWh. When the cooling water can be used in district heating systems, the corresponding figure 0.12-0.14 SKr/kWh. In addition to coal power, wind power is expected to be used as a "replacement" technology, although on a much smaller scale than coal power.

1/ 1 SKr \approx .24 US\$.

2/ The first new power plant, built in order to replace nuclear capacity, is expected to be taken into operation not earlier than 1987.

The cost estimates for wind power seem to be very uncertain, and vary between 0.14 and 0.30 Skr/kWh.

The curve MC_C can be expected to be steeper during the initial part of the period, because most of the conservation efforts have to be made in existing plants and buildings. In the later part, however, more conservation and conversion can take place at the *ex ante* stage, that is, when new plants and buildings are designed. Consequently MC_C will then be flatter.

Generally much less is known about MC_C than about MC_R and MC_N . However, it should be noted that only a part of MC_C is relevant in the present context. Cost minimization implies that conservation and conversion efforts should not be carried further than the cost limit given by MC_R . Moreover, conservation and conversion investments which are profitable also when the nuclear power plants are used, cannot be included in the set of measures to be taken in order to compensate for the loss of nuclear capacity. Such investments should be carried out anyway, and are thus not specific to the discontinuation case.

The highest unit cost of electricity at which conservation and conversion investments are profitable in all cases is given by the marginal cost of the electricity production system in the case when the nuclear plants are used. In Figure 1, this cost level is denoted by d. Obviously the curve MC_C should be fitted into the figure in such a way that it passes through d. Moreover, it is only the segment dE of MC_C that is relevant in our analysis.

The level of the marginal cost of the electricity production system at a given point in time, the point d in Figure 1, to a large extent depends on how well the production capacity is adjusted to demand. If that adjustment is perfect, as a result of good demand predictions or good luck, an equilibrium on the electricity market can be maintained at a price corresponding to the long-run marginal cost^{1/} of an electricity production system, which is optimally designed from the cost point of view.

1/ That is, the sum of capital and running costs connected with a small increase of electricity production.

If the capacity is too small, some demand has to be satisfied by means of peak-load or reserve capacity, which means that the marginal cost of the production system is higher than it had been in an optimally designed system. However, in the opposite case, the marginal cost of electricity will be determined largely by the running costs in existing base-load plants, and consequently be lower than the long run marginal cost of an optimally designed electricity production system.^{1/}

According to the Swedish power industry, a fulfillment of the 12-reactor program would, roughly, lead to equilibrium on the electricity market at a price corresponding to the long-run marginal cost of electricity generated in nuclear power plants. That means that *d* in Figure 1 should be on the level 0.10-0.12 Skr/kWh. However, those who are opposed to the use of nuclear power claim that the official electricity demand forecasts represent significant overestimations. If that is the case, the point *d* should be lower than the level indicated above. However, at the level 0.08-0.09 SKr/kWh it becomes profitable to use electricity as a source of energy in water-borne heating systems. Moreover, export (to Denmark) would also be possible at such price levels. Thus, the point *d* in Figure 1 should be somewhere in the range 0.08-0.12 SKr/kWh.

Using the principles illustrated by Figure 1, together with the cost-estimates discussed so far, leads to a rough estimate of the total cost for the society of closing down the nuclear power plants. However, if one believes that a discontinuation of nuclear power will have a non-marginal impact on the rest of the economy, the partial framework given by Figure 1 is not sufficient. If the nuclear power discontinuation has a significant impact on the rest of the economy, it will affect the prices of commodities and factors of production. Consequently, all the curves in Figure 1 will shift, and those shifts must be estimated before the cost of nuclear power discontinuation can be estimated. But the shifts of the curves, that is, the changes in the commodity and factor price system, can only be estimated within a general equilibrium framework.

1/ In such a case, however, the power industry will make financial losses if prices are set equal to marginal costs. Consequently no investments in new power capacity will be made until the marginal cost of the production system is equal to total (capital and running) costs in new plants.

This is the basic reason why the committee wanted the economic analysis to be carried out with a general equilibrium model. Another reason was that it was interested not only in a total cost estimate, but also in estimates of how this particular policy would affect production and employment in individual sectors. These aspects can also be elucidated in a multi-sectoral model of the type actually used in this study.

However, the use of the model did not exactly conform to the general framework outlined above. There are two deviations of importance. One is that the committee did not try to determine the optimum mix of replacement, conservation and conversion investments which would minimize the total cost of nuclear power discontinuation (The point E in Figure 1). The reason for that was mainly uncertainty about the substitutability of electricity and other factors of production. That is, uncertainty about the factors determining the shape of MC_c in Figure 1.

Instead of trying to determine the cost minimizing electricity consumption development when the nuclear power plants are closed down, the committee investigated three alternatives for a strategy with such an implication. These alternatives represent cases where the energy policy emphasizes different types of adjustment to the loss of nuclear capacity. Thus, in one alternative replacement investments in the power sector are emphasized, while measures which reduce the use of electricity are emphasized in other alternatives. Accordingly, a specific capacity replacement strategy corresponds to each of the alternatives, and electricity demand is assumed to be kept within the limits given by the available capacity by various combinations of price-increases and administrative regulations.

The second deviation from the scheme outlined above was related to the unit of measurement. In Figure 1, the cost of nuclear power discontinuation was defined as the sum of all losses of producers' and consumers' surplus. In principle that is the "correct" measure, but yet the cost was expressed

in terms of reductions of (aggregated) potential^{1/} real consumption of the household sector, i.e. potential consumption evaluated at constant prices. The main reason for that was that the committee's projections should be comparable with the long term economic projections published by the Ministry of Economic Affairs, and these projections are focused on the development of the aggregated potential real household consumption. The drawback with this measure is that it neglects the costs, in terms of losses in consumer surplus, connected with changes in relative prices and the composition of household consumption. This problem will be touched upon again in Section 5 where the results of the study are presented.

4. The Model and the Empirical Basis of the Study

4.1. The structural equations of the model

The original version of the model, as well as its solution algorithm, was described in Bergman and Por, *op.cit.* In this section the basic structure of the model is briefly described and some modifications of the original version are pointed out.

The growth of the labor force as well as net capital formation for the economy as a whole are exogenous to the model. The same applies to technical change and world market conditions in terms of international prices of traded goods, and the volume of international trade. Thus, for a given point in time, world market conditions and the domestic supply of capital and labor is given.

In the model 26 production sectors, 23 groups of traded goods, and 10 consumer commodity groups are identified^{2/}. The model endogenously determines a sectoral allocation of labor and capital, consistent with equilibrium on all commodity and factor markets at prices equal to marginal (and average) production costs. Accordingly production, consumption, foreign trade, and price formation are endogenous to the model.

1/ That is, the level that can be attained when the economy's resources are fully and efficiently utilized.

2/ See Table 4.1 and Table 4.2.

Table 4.1. Production sectors.

-
1. Petroleum refineries.
 2. Electricity.
 3. Agriculture, hunting and fishing.
 4. Forestry and logging.
 5. Mining and quarrying.
 6. Sheltered food manufacturing.
 7. Import-competing food manufacturing.
 8. Beverage and tobacco manufacturing.
 9. Textile, wearing apparel and leather industries.
 10. Manufacture of wood and wood products.
 11. Manufacture of paper and paper products.
 12. Printing and publishing.
 13. Manufacture of rubber products.
 14. Manufacture of chemicals and chemical products.
 15. Manufacture of non-metallic mineral products.
 16. Iron and steel.
 17. Other basic metal industries.
 18. Manufacture of fabricated metal products, machinery and equipment, except shipbuilding and repairing.
 19. Shipbuilding and repairing.
 20. Manufacturing industries not elsewhere classified.
 21. Construction.
 22. Wholesale and retail trade.
 23. Transport, storage and communication.
 24. Private services not elsewhere classified.
 25. Letting of dwellings and use of owner-occupied dwellings.
 26. Community, social and personal services.
-

Table 4.2 Consumer commodity groups

-
- | | |
|---------------------------------|-------------------------------|
| 1. Food. | 6. Housing services. |
| 2. Beverages and tobacco. | 7. Private transport. |
| 3. Clothing. | 8. Leisure activities. |
| 4. Cultural goods and services. | 9. Furniture. |
| 5. Hygiene. | 10. Other goods and services. |

On all commodity markets in the model economy the supply originates from domestic production and, with some exceptions, import. In all domestic production sectors capital, labor, fuels, and electricity are substitutable factors of production, while the use of produced non-energy inputs is proportional to output. The production technology exhibits constant returns to scale in all sectors. Consequently the equilibrium price of production sector output, P_j , is equal to average production cost.

The technology in a given production sector j can be summarized by a unit cost function

$$P_j = P_j^* + \sum_{i=2}^n P_i^D a_{ij} + V \bar{P}_j \bar{b}_{jj} + \theta_j P_j ;$$

where P_i^D is the market price of commodities of type i , $V \bar{P}_j \bar{b}_{jj}$ is the cost of complementary imports^{1/} and $\theta_j P_j$ is the net indirect tax per unit of output. The market price, P_i^D , is a weighted average of the import price of commodity i and the domestic production cost of that commodity. The weights are determined by the share of imports in the domestic supply of commodity group i .

The variable P_j^* , the "net" unit cost of producing commodity j , can be expressed as a function of the "prices" of capital, labor, fuels, and electricity. This function is derived from explicit production functions and the assumption that producers maximize their profits. Since the production technology exhibits constant returns to scale, this is equivalent to assuming cost minimization behavior.

The production functions are of a nested CES and Cobb-Douglas type. Thus, there is a constant elasticity of substitution between a composite capital-labor input, defined by a

1/ The coefficient \bar{b}_{jj} is the use of complementary imports per unit of output in sector j , \bar{P}_j is the world market price of that commodity and V is the exchange rate.

Cobb-Douglas function, and a composite fuels-electricity input, defined by a CES-function. This formulation is rather restrictive, particularly in terms of its implications for the substitutability of the four variable inputs. For this reason an additional version of the model, where the net unit cost variable, P_j^* , was derived from a generalized Leontief cost function, was implemented.

However, the econometric estimation of the parameters of these functions that could be carried out within the time limit of the study did not lead to satisfactory results. One reason for this was that the quality of the price-data was poor. Another reason was the difficulty of specifying and measuring the energy input variables in an analytically meaningful way in some industries.^{1/} Instead the study was carried out with the original version of the model. The parameter values were chosen partly on the basis of other econometric results in the same field, partly on the basis of an iterative procedure where energy use projections obtained with the model were compared with similar projections obtained with other methods.

The share of imports in the domestic supply is assumed to be determined by domestic production costs, P_i , in relation to world market prices expressed in the domestic currency unit, VP_i^{WI} , and a trend. Thus, the import of commodity group i , M_i , is determined by

$$M_i = m_i (X_i - Z_i) \quad ,$$

where X_i is domestic production and Z_i exports and

$$m_i = m_i^0 \left(\frac{P_i}{(1+\phi_i) VP_i^{WI}} \right)^{\mu_i} e^{\mu_i^* t} \quad ;$$

1/ For instance, in the steel industry coal is used both as a source of energy and as an input in the production process. In the pulp industry various waste products are used as an energy source.

where m_i^0 is a constant and ϕ_i a custom duty. The share of imports in domestic supply, $m_i/(1+m_i)$, affects the market price of the commodity group i , P_i^D , and thus domestic production costs, through the equation

$$P_i^D = \frac{m_i}{1+m_i}(1+\phi_i)VP_i^{WI} + \frac{1}{1+m_i}P_i \quad .$$

The numerical values of the parameters μ_i in the import share equations were chosen on the basis of the results of other studies, and on iterative procedure where import projections obtained from this model were compared with import projections made by the Ministry of Economic Affairs. In that process the trend factors, μ_i^* , also were determined.

This completes the brief description of the supply side in the model economy, and next we turn to the demand side. The intermediate demand for goods and services is determined from the assumption about fixed proportions between output and the use of produced, non-energy inputs in the production sectors. On the final demand side, real public consumption is exogenously determined. That "almost" applies to gross investments as well, since net investments and the total capital stock in the economy are exogenously determined. Thus, gross investments have an endogenous element only because the sectoral allocation of the capital stock is endogenous, and depreciation rates differ between the sectors.

However, household consumption expenditures as well as export demand are highly endogenous final demand components. The demand for consumer goods and services by the household sector is assumed to be a function of the relative prices of those goods and services and the disposable income (less saving) of the household sector. More specifically household demand is represented by a so-called linear expenditure system.^{1/}

1/ The system was estimated by A. Klevmarcken, and published in Dahlman, C.J. and A. Klevmarcken, Den privata konsumtionen, 1931-1975, IUI, Uppsala 1971.

In the original version of the model household consumption demand was represented by a system of demand equations with constant price and expenditure elasticities. This system was replaced by the linear expenditure system both for theoretical and empirical reasons. Thus, the original system satisfies the budget constraint only if very special assumptions about the parameters are made, and consequently it is generally not consistent with utility maximization subject to a budget constraint within the household sector. Moreover, the estimation of the linear expenditure system was based on better data than the original system.

The system of demand equations applies to 10 different consumer commodity groups while the original system applied directly to the commodity groups produced by the production sectors. In order to "transform" the demand for these 10 commodity groups into demand for the 26 commodity groups which are produced and imported, the consumer commodity groups have to be defined in terms of the 26 produced or imported commodity groups. That is done by means of a 26×10 matrix, where the elements in each column add up to unity. This matrix also "transforms" the market prices of produced and imported commodities into prices of consumer commodity groups.

The export functions, finally, are simply the import functions of the "rest of the world". Although a considerable share of output in many industrial sectors in Sweden is exported, Swedish producers have a limited influence on world market prices and the volume of international trade. Accordingly the export from each of the trading sectors is assumed to depend partly on the relation between domestic production cost and the world market price, partly on the exogenously determined development of international trade with the commodity group in question. The export functions can be written

$$z_i = z_i^0 \left(\frac{P_i}{VP_i^{WE}} \right)^{\epsilon_i} e^{\sigma_i t} ;$$

where z_i^0 is a constant.

The price-elasticity parameters, ϵ_i , had to be determined on a very poor empirical basis. Basically it was assumed that the substitutability of commodities with the same classification but different origins is roughly the same in Sweden as in Sweden's main trading partners. Thus, the price-elasticity parameters in the export functions, ϵ_i , should approximately be equal to the corresponding parameters in the import functions, μ_i . However, the domestic producers are likely to have some advantages on their home-market, and consequently the absolute value of ϵ_i should be slightly higher than the absolute value of μ_i .

On the basis of this kind of reasoning, the parameters μ_i were used as starting points for the estimation of the parameters ϵ_i . The final set of ϵ_i :s came out from an iterative process where export projections obtained from the model were compared with other long-term export projections.

In order to "close" the model, equilibrium conditions for all commodity and factor markets, including the currency market, are needed. However, the specification of these equilibrium conditions is obvious and need not be repeated here. It may be added that in the model the price system is normalized so that the general price level is kept constant over time.

4.2. The treatment of the electricity sector

In the model the electricity sector is treated in the same way as other production sectors. That posed some problems in this particular study. One rather trivial problem was related to the units of measurement. Like in most economic models, quantities are generally measured in terms of constant-price values in this model. In a study focused on the production and use of electricity, however, it is more convenient to measure electricity in physical terms.

A change from constant-price units to physical units primarily affects the scaling of the production function parameters. However, the sectoral allocation of electricity consumption in

physical units usually does not coincide with the corresponding allocation in constant-price units. The reason for this is obvious; electricity is not delivered at the same voltage to all sectors, and consequently distribution costs and prices differ between the sectors. Thus, in order to make the physical electricity balance consistent with the constant-price electricity balance, one has to recognize that the average price of electricity is not the same in all sectors, and to introduce some mechanism that determines the sectoral structure of electricity prices. In this study electricity was measured in physical units, and it was assumed that intersectoral electricity price relations are stable over time and equal to those observed at the initial point in time. Accordingly, there is one electricity price for each production sector, but all these sector specific electricity prices change in accordance with a general electricity price index which is endogenously determined in the model.

A more important problem was related to the assumption that capital can be reallocated between the sectors and that the technology exhibits constant returns to scale. Due to the long gestation periods in the power sector, these assumptions are applicable on that sector only when the time horizon is several decades ahead. Moreover, when there is a considerable amount of hydropower in the system and hydropower cannot be exploited further, which is the case in Sweden, the constant returns to scale assumption is not applicable at all.

Thus, when the time horizon is 10 or 20 years ahead, the marginal cost curve of the electricity production system in Sweden is strongly upward-sloping. This is because the running cost in hydropower stations is negligible while the running cost in peak-load plants like gas turbines and oil fired plants is very high. Within the time limit of this study it was not possible to reformulate the model in order to take these features into account in a proper way. Instead a substitute approach had to be adopted. The approach can be described by means of Figure 2 below.

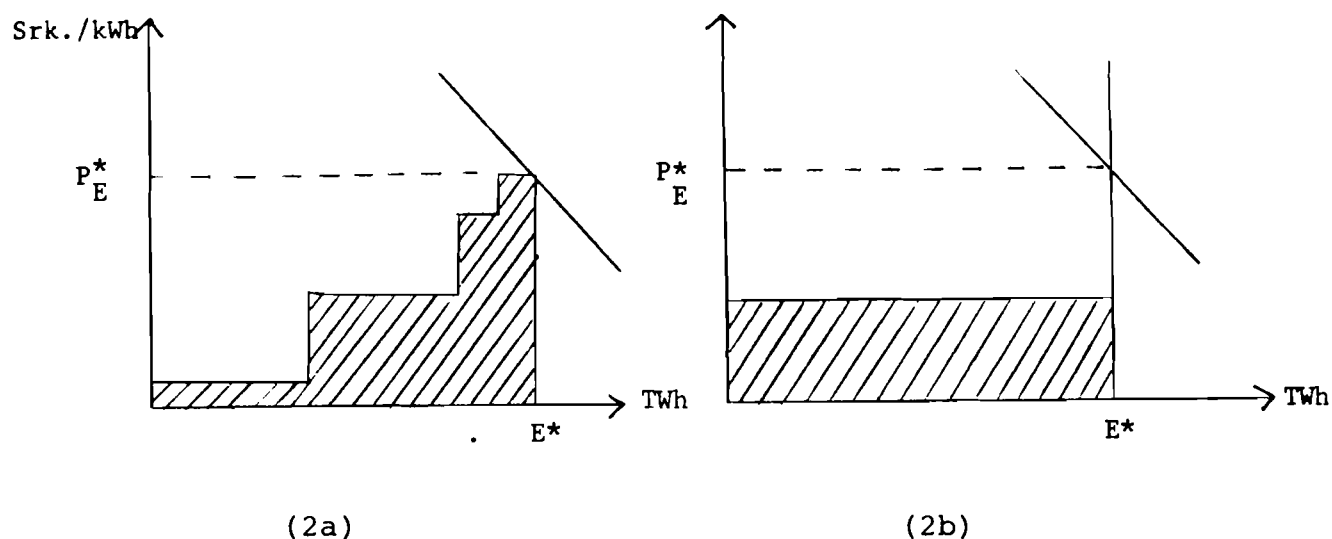

Figure 2.

The figure depicts two power systems with identical demand conditions. Prices are assumed to be set in accordance with marginal cost. In the system in 2a the marginal cost is increasing, and a market equilibrium is attained at the output level E^* . The other system has a constant marginal cost up to a capacity limit which happens to be at E^* . By adding a suitable "scarcity rent" to the marginal cost, market equilibrium can be attained at E^* . Obviously it can happen that the total cost, i.e., the area under the marginal cost curve, is the same in the two systems. If that actually is the case, like in Figure 2, the two systems affect the rest of the economy in the same way as long as the demand curve does not shift; output is the same, total cost is the same and marginal cost, defined in such a way that it includes the "scarcity rent", is equal in the two systems.

The actual Swedish power system can be described by a diagram similar to 2a, while the electricity production system in the model economy can be represented by a diagram like 2b. Thus the problem was to choose the production function parameters in the model economy's electricity sector in such a way that a situation like the one depicted in Figure 2 was accomplished at a given price system. That was done in the following way.

As was mentioned in the previous section, the committee defined the investigated alternatives in terms of constraints on the use of nuclear power and the annual output of the power system. A special expert group identified cost minimizing investment and operation plans for the power system under these constraints. These plans could then be transformed into input requirements at the predetermined output level, like E^* in Figure 2, as well as into estimates of marginal and total cost at that output level.

Then the production function parameters of the electricity sector, as well as a scarcity rent on electricity, were calculated with these estimates as constraints. As a result the total and average costs of the model economy's electricity sector were the same as the corresponding estimates for the real electricity sector at the given output level and input price system. That also applied to the marginal cost, provided it is defined to include the scarcity rent on electricity. In this way the impact of the electricity sector on the rest of the economy could be reasonably well represented in spite of the constant returns to scale property of the technology in the model.

4.3 Numerical values of model parameters and assumptions about exogenous variables

The empirical basis of the study consists of three components: A description of the state of the economy in 1975, a set of parameter values for production, consumption, import and export functions, and a set of projections for the exogenous variables of the model over the period 1979-2000. The first part is simply an input-output table on a 26-sector level for 1975, together with capital stock and employment data for that year. These data, which are readily available, provide a starting point for the projections. Thus, the constants appearing in various parts of the model are chosen so that it reproduces the data-base if the exogenous variables are given their 1975 values.

The projections of future world market relative prices are based on a study made by Leontief et al.^{1/} for the UN. (The projections actually used can be seen in Table 4.3.) The assumptions of all other exogenous variables, i.e., labor supply, capital formation, productivity increase and real public consumption, were made within the committee, primarily on the basis of a recent long-term forecast by the Ministry of Economic Affairs.^{2/} Thus, the supply of labor, in man-hours, was assumed to decrease by 0.6% per annum, while the economy's stock of capital was assumed to grow by 2.5% per annum 1979-2000. The productivity assumptions can be seen in Table 4.3.

The problems in connection with the data base were all related to the estimation of the parameters of the model's structural equations. Only for the consumption functions were estimated parameter values, obtained by means of conventional econometric methods^{3/} available. Accordingly the production and trade function parameters had to be estimated with rather rough methods.

Some of the production function parameters were derived from the input-output table on the basis of the neoclassical distribution theory. The remaining parameters, the elasticity of substitution between electricity and fuels and between energy (electricity and fuels) and primary factors of production (capital and labor), were determined in the following way.

On the basis of published econometric studies, upper and lower bounds were determined for these parameters. Then the

1/ Leontief, W.W. et al., *The Future of the World Economy*, New York, 1977.

2/ *Långtidsutredningen 1978*, SOU 1978:78, Ministry of Economic Affairs, Stockholm, 1978.

3/ See the discussion on p.14.

Table 4.3. Numerical values of selected exogenous variables and parameters

Sector	Annual rate of technical change (% per year) ^{1/}	World market price 2000 (1975=1.00) ^{2/}	Export price elasticity ^{3/}	Import price elasticity ^{4/}
1	0	3.05	-	0.5
2	1.5	-	-	-
3	0	1.11	-2.5	1.5
4	0.1	0.90	-1.5	0.8
5	2.2	1.00	-2.0	1.0
6	0	0.93	-0.5	0.2
7	0.7	0.93	-2.0	1.0
8	0.6	0.93	-2.0	1.0
9	2.5	0.92	-1.5	0.8
10	2.6	0.90	-3.0	1.5
11	2.6	0.90	-3.0	1.5
12	2.7	0.84	-1.2	0.8
13	2.7	0.90	-3.0	1.5
14	2.0	0.99	-1.5	1.0
15	0.9	0.94	-1.0	0.5
16	4.6	0.96	-1.5	0.8
17	4.6	0.96	-1.5	0.8
18	4.2	0.96	-2.0	1.0
19	1.5	0.82	-1.5	1.0
20	3.7	0.96	-2.0	1.0
21	3.5	-	-	-
22	2.0	1.00	-0.3	0.2
23	3.5	1.00	-0.3	0.8
24	0	1.00	-0.3	0.2
25	0.6	-	-	-
26	0	-	-	-

model was used to generate development paths for fuels and electricity input coefficients in the production sectors both for "high" and "low" values for the substitution parameters. These development paths were then compared with projections of fuels and electricity input coefficients made within the committee, primarily on the basis of predictions made by the National Swedish Industrial Board.

After a number of revisions of the elasticity of substitution assumptions within the given boundaries, a set of assumptions which made the two types of projections reasonably similar were identified. Since the whole approach is very rough, there was no point in differentiating the elasticity of substitution assumptions between the industrial sectors. For the housing sector, however, different assumptions were adopted. This was because some estimates of the costs for energy conservation measures were available for this sector.

The result of this procedure was that the elasticity of substitution between primary factors of production and energy was assumed to be 0.25 in the industrial sectors and 0.75 in the housing sector. The elasticity of substitution between fuels and electricity was assumed to be 0.25 in the industrial sectors and 0.50 in the housing sector.

The determination of the import and export price elasticities was carried out in a similar way. Here the above-mentioned world market price projections, the import and export projections made within the committee and an unpublished study of Swedish import price elasticities were taken as the points of departure. After a large number of model runs, a set of reasonable import and export price elasticities, which made the model projections of import and export very similar to the committee's projections for these magnitudes, were identified. The values finally adopted can be seen in Table 4.3.

On the basis of these assumptions and projections of the development of exogenous variables, a "reference development path" for the Swedish economy could be determined. As a result of the way in which various parameters in the model were

estimated, this reference path closely conformed to recent projections made by the Ministry of Economic Affairs. These projections, as well as the reference development path, are based on the assumption that the nuclear power program will be fulfilled, i.e., that twelve nuclear reactors will be in operation around 1985 and that these reactors will be used over their full life-time. Moreover, it is assumed that the Swedish economy will gradually move closer to an equilibrium with less pronounced inter-sectoral profit differentials and a considerably smaller deficit on the current account. The reference development path can be summarized in the following way.

The annual rate of real GNP growth 1979-2000 is 2.6%. The corresponding figures for real private consumption is 1.9% and for real public consumption 1.5%. Real consumption is expected to grow slower than real GNP partly because of an increase in the share of investments in GNP, partly because of a deterioration of the terms of trade, which to a large extent is the result of an expected rapid increase in oil prices. Thus, the world market price of oil, in real terms, is expected to increase by approximately 3% per annum between 1979 and 2000. The corresponding figures for coal and nuclear fuel are 3% and 1.7% respectively. The expected growth of electricity consumption 1979-2000 is 2.7% per annum. In the sub-period 1979-1990 the corresponding figure is 3.4%, which means that the expected level of electricity consumption in 1990 is 125 TWh.

5. Results

If the nuclear power plants are closed down, that will have an immediate effect on the price of electricity as well as on the demand for investment goods and the import of fossil fuels. These effects will induce a number of adjustments in various parts of the economy. Many of these adjustments will lead to a decrease in the use of electricity. Under certain ideal conditions, the new equilibrium on the electricity market will be such that the cost, for the economy as a whole, of discontinuing the nuclear power program is minimized, that is, the market equilibrium will correspond to a point like E^* in Figure 1(p.6).

However, the institutional framework of the electricity market is not such that the market equilibrium necessarily will have such properties. Moreover, if the nuclear power program actually is discontinued, a number of additional policy-measures will also be taken in order to affect various factors influencing the electricity market. For instance, it is most likely that additional installation of electric heating in permanent dwellings will not be allowed. It is also possible that other restrictions on the use of electricity for certain purposes will be imposed and permissions to expand the capacity in electricity intensive industries may not be given. In addition, the rate at which replacement investments in the power sector can be carried out to a large extent depends on if and when the necessary permissions from the central and local governments are given.

Thus the equilibrium that actually will be established on the electricity market very much depends on the type of energy policy that is carried out if the nuclear power program is discontinued. According to the general principles of Swedish energy policy, however, the mix of policy measures should be such that the cost of discontinuing the nuclear power program is minimized for the economy as a whole. However, in practice the empirical basis for identifying an electricity consumption development consistent with these principles is not sufficiently good. Thus, instead of trying to determine the cost minimizing mix of replacement, conversion and conservation investments, the committee investigated three alternative strategies, each emphasizing different types of adjustment to the loss of nuclear capacity.

In the following, the alternatives will sometimes be described in terms of their characteristics, primarily the level of electricity consumption 1990. The committee came to the conclusion that due to bottleneck problems and other constraints, 105TWh can be regarded as the maximum attainable level of electricity consumption level 1990. It also came to the conclusion that an electricity consumption level below 95TWh in that year

could not be reached without considerable costs. The exact formulation of the alternatives analyzed in this study is based on these conclusions of the committee.

5.1. The alternatives

All the alternatives explicitly treated in the analysis are based on the assumptions about the general economic development presented in section 4.3. Thus, they only differ with respect to the assumptions about nuclear power policy and energy policy in general. The alternatives can be defined in the following way.

The reference case

In this case the nuclear program is fulfilled, which means that in addition to the six nuclear reactors now in operation, six more reactors will be taken into operation before 1985 and all twelve reactors are used over their full lifetime.

The replacement case

This case implies that no new nuclear reactors are taken into operation, and those now in operation are closed down between 1986 and 1990. In addition, the use of electric heating is restricted to dwellings and other spaces where it is already installed. A major effort to replace the nuclear capacity by coal fired plants, which means that 105TWh electricity can be supplied by 1990 is made. The market price of electricity is adjusted in order to keep the demand at that level.

The conservation case I

This case is equivalent to the replacement case in terms of the use of nuclear power. However, in this case a relatively small share of the loss of nuclear capacity is replaced by other electricity generation capacity; in 1990 the capacity in the electricity production system only corresponds to an annual consumption of 95TWh. Instead there is a strong emphasis on measures reducing the use

of electricity, and the conservation efforts are concentrated to the non-industrial parts of the economy. The restrictions on the use of electric heating are more far-reaching than in the replacement case. The market price of electricity is increased in order to keep consumption at the 95TWh level.

The conservation case II

This case is equivalent to conservation case I in terms of the development of the electricity production system and the consumption of electricity. It also implies the same restrictions on the use of electric heating as conservation case I. However, the concentration of conservation efforts on the non-industrial part of the economy is not as pronounced as in that case. Moreover, in conservation case II the substitution of oil for electricity is restricted so that the import of oil is not higher than in the replacement case. As in conservation case I, the market price of electricity is increased in order to keep demand at the 95TWh level.

In the following, the calculated development of the economy in each of the nuclear power discontinuation cases is compared with the development in the reference case. The differences will be taken as estimates of the impact on the economy of a discontinuation of the Swedish nuclear power program.

5.2. The Impact on the Macroeconomic Level

To begin with, the impact on the macroeconomic development is investigated. Throughout, real public consumption is assumed to conform to the forecast recently made by the Ministry of Economic Affairs^{1/}. It is also assumed that, except for the electricity production sector, total *net* investments^{2/} in the

1/ That is 1.5% per annum 1979-2000.

2/ The sectoral allocations of these net investments, however, is endogenously determined in the model.

economy develop in accordance with this forecast. This means that total *gross* investments can differ between the cases as a result of different amounts of replacement investments in the electricity production sector, and because of the combined effect of differences in the sectoral structure of the economy and different rates of depreciation of the capital stock in various sectors.

Thus, the truly endogenous macroeconomic variables are real household consumption, real net exports (exports minus imports) and real GNP. Of these, real household consumption^{1/} is the best, although not a perfect, indicator of the material standard of living in the country. Accordingly, we focus on that variable in the following discussion. In Tables 5.1-5.3 the calculated differences in terms of the macroeconomic variables between the reference case and the three other cases are presented.

Table 5.1 The Impact on macroeconomic variables 1990 and 2000 in the replacement case*

	<u>10⁹ SKr (1979)</u>		<u>Percentage points</u>	
	<u>1990</u>	<u>2000</u>	<u>1990</u>	<u>2000</u>
Household consumption	-8.4	-6.7	-2.9	-1.9
Public consumption	0	0	0	0
Gross investments	3.3	0	2.3	0
Exports	3.2	4.4	1.2	1.2
Imports	0	-0.6	0	- .2
GNP	-1.9	-1.7	- .3	- .2

* Absolute and relative differences from the reference case.

1/ Or rather the sum of household and public consumption, but since we investigate the differences between the cases and the development of public consumption is taken as given, it is sufficient to study the development of household consumption.

Table 5.2 The impact on macroeconomic variables 1990 and 2000 in the conservation case I*

	<u>10⁹ SKr (1979)</u>		<u>Percentage points</u>	
	<u>1990</u>	<u>2000</u>	<u>1990</u>	<u>2000</u>
Household consumption	-6.5	-11.3	-2.2	-3.2
Public consumption	0	0	0	0
Gross investments	-0.8	-1.2	- .5	- .7
Exports	-0.3	-0.5	- .1	- .1
Imports	-3.5	-5.6	-1.8	-2.2
GNP	-3.5	-7.4	- .5	- .9

* Absolute and relative differences from the reference case.

Table 5.3 The impact on macroeconomic variables 1990 and 2000 in the conservation case II*

	<u>10⁹ SKr (1979)</u>		<u>Percentage points</u>	
	<u>1990</u>	<u>2000</u>	<u>1990</u>	<u>2000</u>
Household consumption	-8.3	-16.5	-2.9	-4.7
Public consumption	0	0	0	0
Gross investments	-0.9	-1.5	- .6	- .8
Exports	-2.4	-2.9	- .9	- .8
Imports	-6.3	-10.5	-3.4	-4.3
GNP	-5.3	-10.4	- .8	-1.3

* Absolute and relative differences from the reference case.

As can be seen in the tables, a discontinuation of the nuclear power program affects real household consumption both through an increase in net exports and a decrease in GNP. Generally, the former effect is quantitatively more important than the latter. The decrease in GNP is entirely an effect of reduced allocative efficiency^{1/}; capital and labor has, to an increasing degree, to be used to reduce the use of electricity per unit of output rather than to increase output.

Although the three discontinuation cases have many similarities, there are also some rather important differences. In the replacement case, the impact on GNP is smaller than in the conservation cases. This is, of course, due to the less ambitious electricity conservation program in the replacement case. However, in terms of the loss in real household consumption, the smaller loss in GNP is more than counterbalanced by an increase in gross investments during the first part of the period, here represented by the year 1990.

That is the result of the far-reaching replacement of nuclear capacity with other electricity generation capacity in this case. As a consequence of the temporary increase in capital formation, however, the productive capacity of the economy, in terms of GNP, at the year 2000 is not much lower than in the reference case, but significantly higher than in both conservation cases. This means that the choice of time horizon for the analysis has a definite impact on the ranking of the cases in terms of the present value of the loss of real consumption between the initial and the terminal year of the analysis.

The replacement case also differs from the conservation cases in terms of the development of export and import. Due to the somewhat lower GNP the volume on non-energy imports is decreased, but as the use of coal for electricity production increases and oil replaces electricity in some uses, the import

1/ Observe that the supply of capital and labor is exogenously given. The possible effect of this feature of the model will be discussed in conjunction with the discussion of the impact on factor prices.

on fossil fuels increases. In the replacement case the net effect in volume, or constant price, terms is zero 1990 and slightly negative at the year 2000. Due to the assumption that fossil fuel prices increase faster than other import prices, however, the change in import composition increases total imports in value terms. Accordingly net export in volume terms have to increase in order to maintain external balance. This effect explains why the level of household consumption in the replacement case is significantly lower than in the reference case in spite of the small difference in terms of real GNP. In the replacement case, the higher net exports imply a larger volume of gross exports than in the reference case. In the conservation cases, on the other hand, the decrease in GNP is larger and the increase in fossil fuel imports smaller than in the replacement case. As a result the necessary increase in net exports takes place at a lower level of gross exports than in the reference case.

The differences between the cases in terms of the macroeconomic development can be seen as a summary description of a number of differences on the microeconomic level. These include differences in terms of input-output relations in the production sectors as well as differences in foreign trade and domestic consumption patterns. Each of the cases represent an equilibrium in the economy. Consequently the system of relative goods and factor prices also differ between the cases.

In the discontinuation cases the equilibrium price of electricity is higher than in the reference case. This is primarily because the replacement of the nuclear capacity with other electricity capacity leads to higher production costs. But since there are also limitations on the rate at which replacement capacity can be installed, the market clearing price might be higher than the direct cost of producing electricity.

Higher prices on electricity stimulate the use of less electricity intensive methods of production. Thus, in the discontinuation cases production methods are characterized by a less intensive use of electricity and a more intensive use of capital, labor and fuels than the production methods used

in the reference case. In spite of the possibilities of substituting other inputs for electricity, the production costs, and in the long run also the prices, for electricity intensive products will be higher in the discontinuation cases than in the reference case. Consequently the sectors producing such products will be less competitive on domestic and foreign markets.

If some sectors are less competitive in the discontinuation cases than in the reference case, the opposite must hold for some other sectors. Otherwise there will be insufficient demand for labor and capital and external balance cannot be maintained. Accordingly equilibrium in the discontinuation cases implies that the higher electricity prices have to be balanced by lower prices on other inputs. Since the prices of produced inputs are derived from the prices of primary inputs, that is, capital, labor and natural resources, the higher electricity prices have to be balanced by lower wages, profits and rents. Since the model does not treat natural resources explicitly, these effects will be entirely reflected in wages and profits in this analysis.

The electricity price increase discussed so far applies to high voltage electricity, i.e., the output of the electricity generation plants. The cost of distributing electricity and transforming it to a voltage which is suitable for various kinds of consumers should not, however, differ between the four cases. Since the distribution costs varies between different categories of consumers, a uniform absolute increase in the consumer prices of electricity does not imply a uniform relative increase of those prices.

As can be seen in Table 5.4 below, the equilibrium price of electricity used by heavy processing industries, that is, electricity delivered at a relatively high voltage, is about 50% higher in the replacement case than in the reference case. The corresponding figures in the conservation cases are 80% and 100% respectively. As was mentioned before, a replacement of nuclear power plants by coal fired plants would increase the long run marginal cost of the Swedish electricity production system by 30-50%. Thus all the three discontinuation cases

Table 5.4. Calculated percentage differences i sectoral electricity prices between the reference case and the discontinuation cases 1990.

Sector	Replacement Case	Conservation Case I	Conservation Case II
1	41	65	77
2	-	-	-
3	30	43	52
4	33	47	57
5	42	70	84
6	28	36	44
7	26	34	41
8	30	43	52
9	16	20	25
10	25	32	40
11	48	82	98
12	13	16	22
13	31	46	56
14	36	57	68
15	33	50	60
16	39	63	75
17	45	77	90
18	29	41	49
19	32	48	58
20	15	18	20
21	26	34	41
22	57*	105*	115*
23	35	54	64
24	34*	54*	59*
25	89*	224*	231*
26	20	22	25

*

Restrictions on the use of electric heating was represented by an extra charge on electricity, chosen so that the consumption of electricity was kept at a predetermined level in sectors 22, 24 and 25.

seem to imply an equilibrium price of high voltage electricity above the long run marginal cost in coal fired power plants, particularly in the conservation cases.

This observation is interesting since the electricity tariffs in Sweden presently are based on the long run marginal cost of high voltage electricity. This analysis indicates that prices set in accordance with these principles will not clear the electricity market if the nuclear power program is discontinued. Thus the equilibrium determined with the model implies that some kind of short run marginal cost pricing will have to be applied or that additional taxes on electricity will have to be imposed.

In principle this is not a difficult problem, but in practice it might very well be. This is because prices have to be set on the basis of the estimated price-elasticity of electricity demand rather than on the basis of production costs. Available estimates of the price-elasticity of electricity demand are uncertain and inconclusive, and may not be applicable at all on substantial price increases. Accordingly a moderate increase of the price of electricity to a level over the long run marginal cost of the electricity production system in conjunction with temporary rationing in periods with excess demand tendencies on the electricity market are likely to be the tools actually used if the nuclear power program is discontinued.

In Table 5.5 below, the equilibrium wage and profit rates in the different cases can be seen. The critical question is whether the factor price development in the discontinuation cases differs from that in the reference case to such an extent that the factor supply assumptions should be revised. If that is the case, the impact of nuclear power discontinuation on GNP is larger than indicated in Tables 5.1 - 5.3. However, the results presented in Table 5.5 do not suggest that such a revision is necessary.

Table 5.5 Differences in calculated equilibrium factor prices 1990 and 2000 between the reference case and the discontinuation cases

	Replacement Case		Conservation Case I		Conservation Case II	
	1990	2000	1990	2000	1990	2000
Wage rate ^{1/}	-1.2	-2.9	-2.4	-5.0	-4.4	-6.7
Profit rate ^{1/}	-3.6	-4.0	-3.6	-4.0	-7.1	-4.0
Profit rate ^{2/}	-0.1	-0.1	-0.1	-0.1	-0.2	-0.1

1/ Difference in % from corresponding reference case value.

2/ Difference in terms of the profit level (percentage points).

All these results depend on a number of assumptions on parameters and exogenous variables in the model. These assumptions are, of course, more or less uncertain. Consequently an analysis of the sensitivity of the results with respect to variations in strategic assumptions is needed.

A number of such sensitivity analyses were carried out. In many cases the results of an individual simulation turned out to be quite sensitive to the assumptions made on parameters and exogenous conditions. For instance, the calculated share of real household consumption in real GNP turned out to be quite sensitive to the assumptions on fossil fuel prices and the growth of Sweden's major export markets. However, the calculated difference between the cases were generally much more robust than the results obtained in simulations of the individual cases.

The assumptions which turned out to be most important for the difference between the four cases dealt with in this analysis were those about fossil fuel prices and the substitutability of energy and primary factors of production, i.e., labor and capital. Thus, when the assumed increase of fossil fuel prices was reduced from 3% to 2% per annum, the loss in terms of real household consumption in the replacement case was reduced from $8.4 \cdot 10^9$ SKr to $7.1 \cdot 10^9$ SKr. In addition the

calculated growth of electricity consumption was lower both in the reference and the replacement case than it was with the original fossil fuel price assumptions.

The most striking result of the reduction in fossil fuel price increases, however, was that the calculated growth of real household consumption was considerably higher in all cases. Thus, in the reference case with the lower fossil fuel prices, the level of real household consumption 1990 was 8% higher than in the corresponding case with the original fossil fuel price assumptions. Moreover, in the replacement case with lower fossil fuel prices the level of real household consumption in 1990 was 5% *higher* than in the *reference case* with the original fossil fuel price assumptions.

However, these results are likely to represent an over-estimation of the importance of fossil fuel prices. This is because the impact of the lower prices of such inputs on the world market prices of non-energy commodities has not been incorporated in the analysis. Thus, the resulting increase in the international competitiveness of the Swedish industry is overestimated. Still it seems reasonable to conclude that the impact on the growth of real household consumption of a discontinuation of the nuclear program is comparable to an impact of an addition to the annual increase of real fossil fuel prices by 1 to 2 percentage points.

In the other sensitivity tests the substitutability of energy and primary inputs was varied. Thus, the elasticity of substitution between aggregated energy and aggregated capital/labor was increased from 0.25 to 0.75 in all industrial sectors. As a result the loss of real household consumption was reduced from $8.4 \cdot 10^9$ SKr to $6.3 \cdot 10^9$ SKr, and the calculated growth of electricity demand was reduced in all cases. The growth of real household consumption was also higher in all cases, but this effect was much less pronounced than in the fossil fuel price sensitivity test.

The approach used in this analysis does not yield any well-defined measures of the uncertainty of the results. However, on the basis of the sensitivity tests actually carried out and with a rough judgement on the accuracy of underlying assumptions it

seems reasonable to expect that the actual impact on the macro-economic level of a nuclear power discontinuation in a general equilibrium context is in the range $\pm 25\%$ around the estimates arrived at in this analysis. The relevance of the general equilibrium approach will be discussed in the concluding section.

5.3 The impact on the sectoral level

Generally the share of electricity costs in total production cost is lower than 2 to 3 % in the Swedish economy. The exceptions from this rule can primarily be found in the iron and steel industry, the paper and pulp industry and the chemical industry. For example, in the electrochemical industry, which is a part of the aggregated chemical industry, the electricity cost share is over 20%. However, since other parts of these relatively electricity intensive aggregated sectors use much less electricity per unit of output, the electricity cost shares of the 26 aggregated sectors explicitly treated in the model are all lower than 4%.

With this background it is not likely that small changes in the relative price of electricity will have a significant impact on the sectoral composition of the economy. Electricity price increases in the order of magnitude discussed in the previous, that is 50 to 100%, are, however, likely to have such effects. These electricity price increases are likely to initiate a change of the structure of the economy in terms of the 26 aggregated sectors distinguished in the model, as well as a change in the internal structure of these sectors. By definition the model results are confined to the first, "between-sector", type of structural change.

In Tables 5.6 and 5.7 the main results of the sectoral analysis can be seen. The estimated impact on the other sectors was quite insignificant.

Table 5.6 Calculated impact on output 1990 and 2000 in selected sectors*

	<u>Replacement Case</u>		<u>Conservation Case I</u>		<u>Conservation Case II</u>	
	<u>1990</u>	<u>2000</u>	<u>1990</u>	<u>2000</u>	<u>1990</u>	<u>2000</u>
Forestry (4)	+ .4	- .8	-1.2	-5.4	- 7.9	-11.0
Paper and pulp industry (11)	+ 0	-1.4	-2.9	-7.8	-14.5	-16.3
Chemical industry (14)	- .3	0	+ .3	+ .4	+ 5.5	- 5.5
Iron and steel industry (16)	+ .7	+ .5	+ .6	+ .6	- 4.1	- 1.2
Manufacturing industry (17)	+1.2	+ .9	+ 0	+ .6	+ 2.1	+ 2.2

* Percentage difference in the level of output between the reference case and the discontinuation cases.

Table 5.7 Calculated impact on employment 1990 and 2000 in selected sectors*

	<u>Replacement Case</u>		<u>Conservation Case I</u>		<u>Conservation Case II</u>	
	<u>1990</u>	<u>2000</u>	<u>1990</u>	<u>2000</u>	<u>1990</u>	<u>2000</u>
Forestry (4)	-1.0	-1.9	-1.9	-5.0	- 9.6	-11.4
Paper and pulp industry (11)	+ .4	- .8	1.6	-5.6	- 12.6	-14.1
Chemical industry (14)	- .3	- .2	+ .9	+ .8	- 4.3	- 4.2
Iron and steel industry (16)	+1.2	+1.0	+1.9	+2.1	-1.7	+ .5
Manufacturing industry (17)	+1.1	+ .9	+ 0	+1.3	+2.3	+ 3.0

* Percentage difference in the level of employment between the reference case and the discontinuation cases.

It is clear from the tables that the combination of higher electricity prices and lower wages and profits implies an equilibrium structure where production and employment are lower in the most electricity intensive sectors, but higher in the less electricity intensive, and rather labor-intensive, manufacturing industry, than in the reference case. The reallocation of resources from the iron and steel industry, forestry and the paper and pulp industry to the manufacturing industry represents an amplification of tendencies which are very pronounced already in the reference case. The relative contraction of the chemical industry, however, represents a weakening of the reference case trend.

The main reason for the contraction of the paper and pulp industry, the chemical industry, and the iron and steel industry, is the reduction in international competitiveness for these sectors, resulting from the electricity price increase. In the case of the paper and pulp industry, there is no counteracting factor, and the reduction in exports leads to a reduction in production and employment. It should be noted that the former effect is somewhat stronger. This is because the reduction in employment is counteracted by substitution of labor for electricity and consequently the methods of production becomes somewhat more labor-intensive.

In the iron and steel industry, however, the reduction in exports is counteracted by an expansion of the domestic market. Because of the electricity price increase, the iron and steel industry loses market shares both at home and abroad, but in spite of that the volume of sales to domestic users increases. The reason for this is the expansion of the manufacturing industry, which is a big user of the output of the iron and steel industry.

The results for the forestry sector are also due to the, in this case somewhat dubious, intersectoral dependencies in the economy. Presently the paper and pulp industry is the main buyer of the output of the forestry sector, and that is of course reflected in the input-output relations (based on data for 1975)

incorporated in the model. However, a substantial electricity price increase may contribute to a change, which is already taking place, of the domestic market for forestry products. The relative competitiveness of the wood products industry is increasing and the use of the forestry output for energy purposes is becoming increasingly profitable. Accordingly, a decline of the paper and pulp industry need not lead to a similar reduction of production and employment in the forestry sector.

5.4 Measures of the total cost of nuclear power discontinuation

The discussion in Section 3 led to the conclusion that the present value of the annual losses of consumer and producer surpluses would be the appropriate one-dimensional measure of the cost of nuclear power discontinuation. However, as was also mentioned in Section 3, the committee preferred to measure that cost in terms of reductions of the aggregate real consumption in the household sector. The basic differences between the two measures are that the latter does not take the composition of real consumption and the relative prices of the consumer commodity groups into consideration.

This means that the adopted measure incorporates costs which are due to ^{1/} reduced productivity and worsened terms of trade, while welfare losses due to changes in consumption patterns tend to be neglected. Accordingly the analysis presented here, *ceteris paribus*, tends to underestimate the cost of nuclear power discontinuation, and more so for the "conservation" cases than for the "replacement" case. This is because it is primarily the household sector which is assumed to change its electricity consumption pattern in the conservation cases. Accordingly, the amount of neglected losses in consumer surplus are more important in those cases than in the replacement case.

1/ To be more precise, lower productivity and worsened terms of trade are *results* of the reallocations in the economy which are induced by a nuclear power discontinuation, but not the *causes*.

In Table 5.8 the results of the present value calculations are presented. The discounting is carried out for two cases with different rates of interest. The expert group which studied the energy supply system generally used 4% interest in their investment calculations. However, on the basis of the assumptions made about exogenous conditions, particularly the rate of capital accumulation, the interest rate endogenously determined in the model was close to 3% in all cases.

It should be noted that the present value calculations only cover the period between 1980 and 2000, while the nuclear power plants not yet in operation can be used until approximately 2010. Thus, the total cost for nuclear power discontinuation should be somewhat higher than the figures presented in Table 5.8.

Table 5.8 The present value* of annual reductions of real household consumption 1980-2000 in relation to the reference case.

	Replacement Case	Conservation Case I	Conservation Case II
4%	70	75	98
3%	77	85	111

* In 10^9 SKr in 1979 prices.

Expressed as a single once-and-for-all payment, the estimated cost corresponds to between 8000 and 14000 SKr. per inhabitant in Sweden. If the whole cost should be paid by those presently in the labor force it corresponds to approximately 3 to 5 normal monthly salaries.

6. Concluding Remarks

It has already been pointed out that the presented cost estimates are likely to underestimate the total cost of nuclear power discontinuation; losses of consumer surpluses are neglected and the present value calculations do not span the full lifetime of the existing nuclear plants. However, there are also

other factors not related to the units of measurement or the time horizon of the analysis which are likely to lead to underestimations. These factors are related to the fact that the analysis was entirely carried out within a general equilibrium framework and on a relatively aggregated level.

When the impact of the investigated policy is defined in terms of differences between equilibrium allocations, various kinds of adjustment costs are, by definition, neglected. For instance, reallocations of the labor force between sectors, regions, and occupations are important parts of the adjustment to a new electricity supply situation. In connection with such reallocations there might be periods of unemployment. Most likely there are some costs for retraining, either in the form of costs for formal education or in the form of low productivity during periods with "on the job training". If people have to move between geographical locations there are costs for the physical transportation, but there can also be capital losses if the net outflow of people from a given location affects the housing market or the base for various kinds of public and commercial services.

The potentially most significant type of adjustment cost is probably the cost due to periods of increased unemployment in connection with reallocations of the labor force. If the attainment of the "new" equilibrium allocation implies substantial reallocation of the labor force, the losses due to a temporary increase of unemployment can be substantial. That is also the case if it takes a considerable time before some industries can expand enough to absorb all those who lost their jobs in industries particularly hurt by the policy in question. The existence and length of such time lags primarily depends on the rate at which relative factor prices can be adjusted when the economy's productivity is reduced. It is obvious that if adjustment problems are significant, that will have an impact on the rate of capital formation and productivity growth.

It is very difficult to estimate the quantitative significance of adjustment costs in connection with a discontinuation of nuclear power. However, a rough indication is given by the difference, in terms of sectoral use of capital and labor, between the reference case and the discontinuation cases. That is, adjustment costs can be assumed to be an increasing function of the need to adjust. On this basis, and considering that the full impact of the nuclear power discontinuation will not be felt until the end of the 1980s, adjustment costs do not seem to be a major share of the total cost of a nuclear power discontinuation; the investigated cases do not differ significantly in terms of the sectoral allocation of the labor force. However, it is quite possible that the relatively high level of aggregation in the model analysis "hides" more significant structural changes.

Another neglected aspect in the model analysis is how the different alternatives affect Sweden's vulnerability to unexpected disturbances in the supply of energy. The discontinuation alternatives increase the economy's dependence on imported fossil fuels, but most of that is an increase of coal imports. However, before the coal power plants can be taken into operation (after 1987) the use of existing oil-fired power plants will increase.

That will make the power system more vulnerable to oil embargos and oil price increases. Moreover, the amount of reserve capacity in the power system will be smaller than in the reference case. This means that a dry year leading to a small output of electricity from hydropower plants will affect cost and capacity conditions more in the discontinuation cases than in the reference case.

However, after 1985 the reference case is more vulnerable to supply interruptions in the nuclear power plants. Thus, if the twelve-reactor program is fulfilled and, for some reason, a rapid discontinuation of these plants is regarded as necessary in the beginning of the 1990's, that is likely to have a significant impact on the economy. Apparently unexpected disturbances can appear in all cases and it is by no means clear whether the neglect of "disturbance" costs means that the differences between the alternatives have been overestimated or underestimated.

One factor that could lead to an overestimation of the cost of nuclear power discontinuation is the way in which the assumptions about future coal prices were made. Since Sweden has no coal deposits the coal has to be imported. The committee's assumption was that the import price of coal would be closely linked to the import price of oil, i.e., that oil should be the price leader on the market for fossil fuels. Accordingly, coal prices were assumed to increase at the same rate as oil prices. That is a reasonable but not obvious assumption. Alternatively it is possible that future import prices for coal primarily will reflect the costs for mining and transportation. If that is the case, the assumption that coal prices will increase by 3% per annum in real terms seems to be on the high side.

Another and more general question is whether available analytical tools are good enough for a meaningful analysis of development paths over a 20-year period. There is, of course, no obvious answer to that question. A model analysis of the kind presented in this report can, however, sort out factors which seem to be the important determinants of future economic development.

The model analysis clearly indicated that the projections often were quite sensitive to variations in underlying assumptions. However that did not apply to all of these assumptions. The most important assumptions turned out to be those about future world market conditions (prices and trade volume) on Sweden's major export markets, the growth of domestic resources (labor and capital), technological advances and the development of oil prices. The development in the paper and pulp industries, not surprisingly, turned out to be quite sensitive to the domestic prices of wood. In fact, reasonable variations in all these assumptions had a more significant impact on the projected development of the Swedish economy than a nuclear power discontinuation.