

NOT FOR QUOTATION  
WITHOUT PERMISSION  
OF THE AUTHOR

INTERLINK, AN INTERINDUSTRIAL MODEL FOR  
SIMULATING A BALANCED REGIONAL ECONOMIC  
DEVELOPMENT AND ITS LINKS TO IIASA'S SET  
OF ENERGY MODELS

Igor Zimin

April 1980  
WP-80-95

*Working Papers* are interim reports on work of the International Institute for Applied Systems Analysis and have received only limited review. Views or opinions expressed herein do not necessarily represent those of the Institute or of its National Member Organizations.

INTERNATIONAL INSTITUTE FOR APPLIED SYSTEMS ANALYSIS  
A-2361 Laxenburg, Austria

THE AUTHOR

I. ZIMIN of the Computing Center, U.S.S.R. Academy of Sciences, Moscow, U.S.S.R., wrote this paper while being a member of IIASA's Energy Systems Program, 1974-1978.

## PREFACE

In recent years, it has been of considerable interest for energy demand and supply analysts to study the linkage of energy and economy and its behavior over the long run. A common feature of such investigations is the high level of aggregation of the models, which seem to be the more highly aggregated the longer the time horizon they consider. This phenomenon may largely be due to the uncertain nature of the relationship between the various economic sectors as well as to our inability to anticipate in sufficient detail the numerous factors that are necessary for a long-term analysis.

In order to evaluate global long-term energy strategies, IIASA's Energy Systems Program has developed a comprehensive set of energy models. One model in this set is INTERLINK, which is presented in this paper. INTERLINK can be described as an input-output system of the Leontief type, providing useful information on the behavior of macroeconomic indicators.

This model is an attempt to balance the high level of aggregation in the model set, by introducing a fair amount of disaggregation in the economic sectors. In particular, it serves to determine the most important characteristics of the relationships between various economic sectors and future energy demand. Over and above, it is also of a more general interest to the energy modeler to obtain feedback on a given energy supply strategy, which the model also provides.

## ABSTRACT

The INTERLINK model is a dynamic linear model simulating development of a national or regional economy as a whole.

The objective of the model is to provide projections of the potential long-term economic development of a region or a nation under various assumptions on the present and the potential future structures of the overall system. The model allows one to evaluate the potential economic growth of a region or a nation within and after the transition period (.i.e., the change from the use of conventional to nonconventional energy sources), to describe the internally consistent operation of several production sectors, to provide information required for energy demand projections, and to identify limiting factors in the development of regional economies.

The model is a dynamic input-output Leontief system with a set of variables, such as GNP, export, import, employment, investment, and final consumption, given both as totals and by sectors. Structural parameters, such as technological and capital coefficients, final consumption profile vectors, and labor-output ratios, are exogeneously changeable over time.

The model can be used both as an optimization model, with various assumptions on the objectives of a given nation or region in the transition period, and as a simulation model, with assumed growth rates for various production sectors and final consumption.

As a result, the model provides estimates of GNP, final consumption, and investment changing over time, for a regional energy system development strategy under consideration.

## CONTENTS

1.	INTRODUCTION	1
1.1	Objectives and Basic Characteristics of the Model	
2.	MAJOR ECONOMIC RELATIONSHIPS DESCRIBED BY THE MODEL	7
2.1	Production and Distribution Subsystem	
2.2	Fixed Capital Stock Dynamics	
2.3	GNP Bounds	
2.4	Personal and Government Consumptions	
2.5	Objective Function	
3.	MATHEMATICAL DESCRIPTION OF THE MODEL	15
3.1	Notation Used in the Model Description	
3.2	Model Equations	
4.	LINKAGE OF INTERLINK TO IIASA'S SET OF ENERGY MODELS	23
4.1	Linkage to the MACRO Model	
4.2	Linkage to the MUSE Model	
4.3	Linkage to the MEDEE-2 Model	
4.4	Linkage to the IMPACT Model	
5.	COMPUTERIZATION OF THE MODEL: SUBMODELS GENPROD, GENEXP, GENCAP, GENCONS, AND GENRHS	37
5.1	Dimensions of the LP Problem	
6.	THE U.S. BASE CASE, AN ILLUSTRATIVE EXAMPLE	47
7.	REFERENCES	53

INTERLINK, AN INTERINDUSTRIAL MODEL FOR  
SIMULATING A BALANCED REGIONAL ECONOMIC  
DEVELOPMENT AND ITS LINKS TO IIASA'S SET  
OF ENERGY MODELS

Igor Zimin

1. INTRODUCTION

INTERLINK is a dynamic linear model for simulating a balanced long-range development of a national or regional economy. It has been developed in IIASA's Energy Systems Program on the basis of a dynamic interindustrial input-output model (Ivanilov and Petrov 1970). The original model was modified and adjusted to meet the specific needs of the energy systems studies at IIASA. Major adjustments were the adaptation of the model to long-term considerations and its use as an operational link to other models developed for a detailed energy systems analysis. This to some extent explains the name of the model: INTERLINK.

The main reason for introducing a dynamic input-output model such as INTERLINK into the set of energy models was the necessity to consider the regional energy supply system development in a close relation to the operation of other economic sectors. Sectoral considerations are necessary because the energy sector supplies all other producing sectors with different kinds of energy and, in turn, consumes various productions of these sectors in the form of raw materials, capital, and manpower.

The Leontief input-output analysis seems to be a useful methodological approach since it provides economic balance between production sectors. At the same time, with the statistical data usually available it currently is the most convenient method to use.

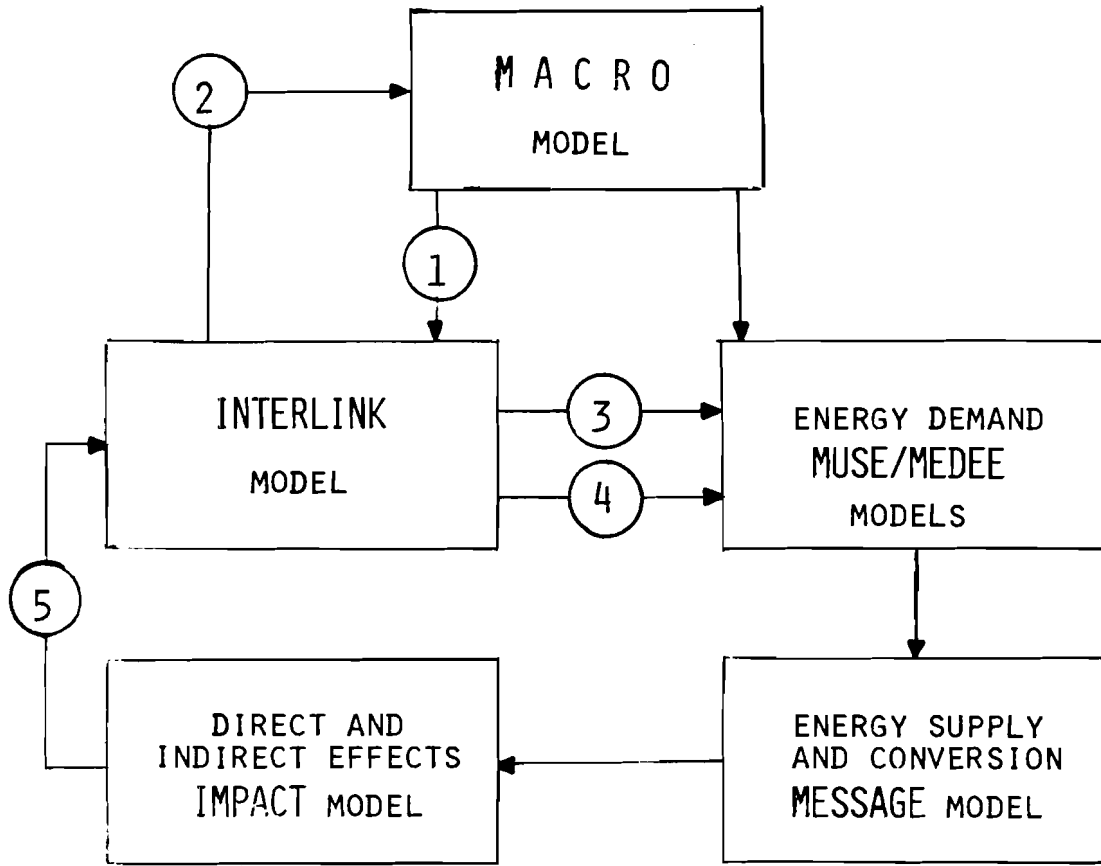

Figure 1. A profile of IIASA's set of energy models. Arrows 1-5 are explained in the text.

The INTERLINK model is more highly aggregated than other comparable models (United Nations 1977, UNIDO 1977); for example, the entire economy is separated into 17 production sectors. Because of the high aggregation of the economic indicators, the model is not expected to provide direct energy demand estimates but rather to generate inputs for energy demand models in terms of the value added and the energy flows to various industrial sectors.

In general INTERLINK as such can be considered an independent model. However, in our studies we purposefully used it as a link between a single sectoral econometric model MACRO (Rogner 1977), the energy demand models MUSE and MEDEE-2 (Lapillonne 1978), and the IMPACT model (Kononov and Por 1979) to estimate direct and indirect costs as well as investment and manpower requirements for the development of the energy sector. The place of INTERLINK in IIASA's set of energy models is visualized by Figure 1. The individual links between the models are briefly described below.

1. MACRO inputs to INTERLINK are GNP<sup>\*</sup>, personal and government consumptions, employment, and labor productivity. The first four inputs should be understood as being scenario targets that are desirable to reach but that can not necessarily be achieved in a balanced economic development.
2. INTERLINK feedback outputs to MACRO include the same variables as 1. The values obtained are those results of the INTERLINK run that can in fact be achieved by an economy under a given energy system development strategy. They may differ from corresponding target values provided by 1. Such deviations may serve as a basis for generating a new scenario of economic development in MACRO by changing the model parameters, such as share of investment, capital-output ratio, and others.
3. INTERLINK provides the following inputs to the MUSE model: GNP, value added by sector, and energy demand pattern per end-use categories. These values can be obtained from INTERLINK after one iteration of the model set.
4. The following values are inputs from INTERLINK to MEDEE-2: GNP and total investment on the one hand; total personal and government consumptions, value added, investment, consumption and gross outputs on the other hand are given by sectors.
5. The IMPACT model provides INTERLINK with direct costs, direct investment, and direct manpower required for developing the energy sectors of an economy.

---

\*Here the term GNP is also used to describe a gross regional product.



All these links are given in dynamic form, i.e. all input and output variables are represented as functions of time over a planning horizon.

In addition, it is in principle possible to link the INTERLINK model to any model that considers in detail operation of a particular industrial sector. For example, instead of MESSAGE, the Hungarian agricultural model HAM (Csakr 1978,1979) could be linked to INTERLINK, for a better representation of technological changes in the agricultural sector (serving as inputs to INTERLINK), in order to evaluate the long-term impact of agricultural development on the economy. Another example is to explicitly represent natural resources constraints in INTERLINK. This can be done either by aggregation of outputs of ENERDYM (Energy Resources Dynamic Model (Grenon and Zimin 1977)) or by direct use of the WELMM data base (Grenon and Lapillonne 1976).

At this point, a few general comments are in order with respect to the application of INTERLINK and its structure.

The general point, which one should never misunderstand when dealing with the modeling of reality, is the *man-machine interaction*. In the case of INTERLINK--and because of its objectives--intuition, experience, and reasoning provided by people working with the model are specifically important. The reason for that is the complexity of the object to be modeled; that is the national economy as a whole. The core of the model is a purely logical structure representing a formalization of basic balances of economic aggregates. Basic feedbacks between these indicators, which are dependent on human behavior by way of certain economic mechanisms and administrative and political decisions, are intentionally left to the users of the model. This is done not because such formalized patterns are lacking or inappropriate, but in order to make the use of the model more flexible. On the one hand, this means that the user may introduce various informal structures (say, qualitative description of price generation mechanisms in a period beyond the year 2000) or changes in the profile of final personal and government consumption or formalized submodels simulating human behavior (for example, relationships between personal income and personal consumption profiles). On the other hand, the model should be flexible in the sense that it can be adapted for future research at IIASA or elsewhere.

The other major observation is that the model does not aim at forecasting future economic development but rather at investigating the consequences of various assumptions or various scenarios of this development. This assumes the following two-step process of interactive use of the model (Figure 2).

1. Start with initial assumptions (scenarios) expressed by particular values of the model's exogenous parameters. Some of the exogenous variables represent so-called target values, for instance, certain levels of GNP, personal consumption, etc.

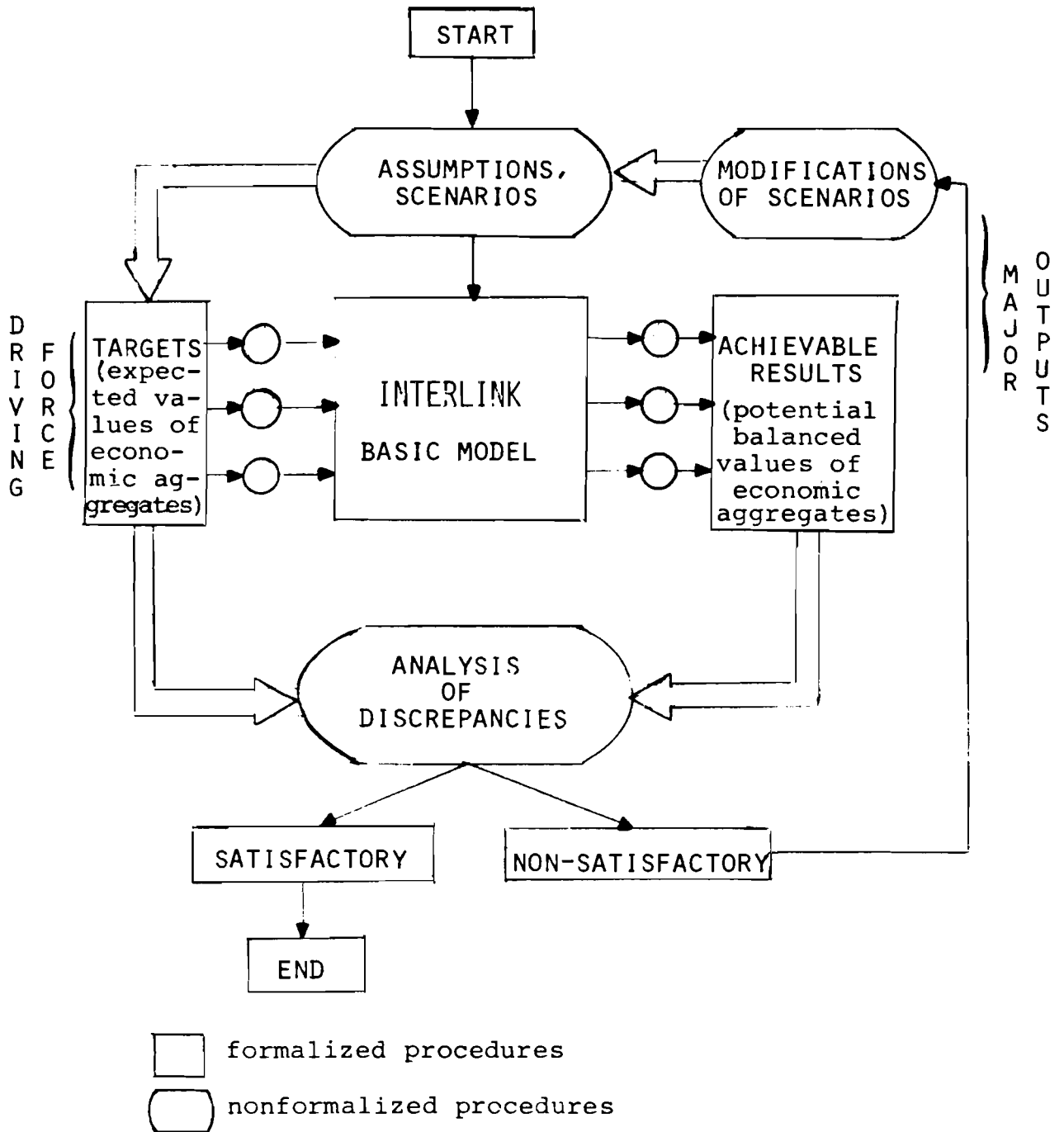

Figure 2. Interactive use of the INTERLINK model.

2. Run the model and compare the results it generates with the corresponding target values. Stop if the results obtained are satisfactory compared with the scenario inputs (assumptions); or otherwise change the initial assumptions (i.e. the exogenous inputs) and continue.

Thus the target values serve to drive the model, and both the results obtained and the modifications of the initial assumptions are major outputs. By results we mean qualitative changes in economic aggregates rather than merely quantitative changes.

Consider, for example, the following problem: how will certain alternative energy system developments influence the final consumption patterns in an economy? This question predetermines the variables to be used in the model structure. In that case, the following macro-economic variables are given exogenously:

- expected GNP,
- expected total personal and government consumptions expenditures,
- demographic variables in terms of potential labor supply or maximum employment,
- technological changes in terms of input and output, capital coefficients, capital-output ratios and labor-output ratios (by sector) changing over time,
- change of relative prices by sector and over time,
- exports and imports by sector and over time,
- change of personal consumption and government expenditure profiles over time,
- capital depreciation factors, and
- change of capital and labor productivity.

Given these exogenous variables, one can use the model to calculate endogenously the values of the following macroeconomic indicators for each production sector and over time:

- gross outputs,
- capital stocks,
- investment goods,
- final personal and government consumptions, and
- value added,

as well as their aggregates:

- GNP,
- total investment goods,
- total personal consumption,
- total government consumption,
- total capital stock,
- actual employment, and
- capital-output ratio for the entire economy.

### 1.1. Objectives and Basic Characteristics of the Model

The main objectives of INTERLINK can be summarized as follows:

- to evaluate potential regional economic growth within and after the transition period (15-60 years from now);
- to provide internal consistency of the operation among various production sectors of the modeled regional economy;
- to provide information on development and operation of various industrial sectors for estimating the potential energy demand; and
- to identify limiting factors in the development of regional economies in the transition period.

The basic characteristics of INTERLINK are the following:

- the model is dynamic and linear;
- it is flexible in the sense of having the opportunity to use various objective functions, various assumptions about production structure (I-O and capital coefficients, capital-output and labor-output ratios), final consumption structure and various sectoral representations of the production system;
- the model is highly aggregated;
- the model does not explicitly take into account mechanisms of control by economic sectors, ownership, or redistribution of goods among various population groups; and
- due to the last two properties the model is easily adjustable and can be applied to both centrally planned and market economies, as well as to developed and developing economies.

The next sections contain detailed descriptions of the model relationships (Section 2), the structure of the basic model actually used in simulation experiments (Section 3), linkages to other models of IIASA's set of energy models (Section 4), computerization of INTERLINK (Section 5), and an example illustrating the application of the model (Section 6).

## 2. MAJOR ECONOMIC RELATIONSHIPS DESCRIBED BY THE MODEL

The model describes four basic processes taking place in any regional economy: production, distribution of goods produced, capital stock dynamics, and final consumption. The operation of any sector requires capital stock, labor, and intermediate goods inputs. The output of any sector and goods imported by an economy are distributed among investment, export, government and personal consumptions, and intermediate goods supply. The time-lagged relationships capture delays between investment and a corresponding increase in fixed capital stock.

## 2.1. Production and Distribution Subsystem

All variables in the model are measured in average annual values. Operation of a regional production system is described in terms of  $N$  producing sectors. Let

- $x_i(n)$  be the gross output (production level) of sector  $i$ ,  
 $i = 1, 2, \dots, N$ ;
- $N$  be the total number of sectors;
- $a_{ij}(n)$  be the input-output coefficients;
- $h_i(n)$  be the net output in sector  $i$ ;
- $n$  be the index of the current time period,  
 $n = 1, 2, \dots, T$ ; and
- $T$  be the length of the planning horizon or the total number of time periods.

Below we assume that each time period is equal to  $\Delta t$  years (for instance,  $\Delta t = 5$  years). Thus the actual time horizon considered in the model equals  $T \cdot \Delta t$  years.

The balance equation describing distribution of goods between intermediate and final uses (not output) is as follows:

$$x_i(n) = \sum_{j=1}^N a_{ij}(n) \cdot x_j(n) + h_i(n) \quad . \quad (2.1)$$

The basic assumption made here is that intermediate consumption in each sector is proportional to the gross output of the sector. Net output, in turn, is subdivided into investment goods, personal consumption (household), government consumption, export and import:

$$h_j(n) = I_j^f(n) + W_j^P(n) + W_j^G(n) + e_j(n) - m_j(n) \quad , \quad (2.2)$$

$$j = 1, 2, \dots, N \quad ,$$

where

- $I_j^f(n)$  = investment goods from sector  $j$  (capital investment by origin);  
 = the amount of goods from sector  $i$  going to the new capital stock created during period number  $n$  (which might not be booked as fixed capital stock in this period because of construction time lags);  
 $W_j^P(n)$  = goods for personal consumption;  
 $W_j^G(n)$  = goods for government consumption;  
 $e_j(n)$  = export of goods; and  
 $m_j(n)$  = import of goods.

Production in each sector and for each time period is limited by the production capacities and labor available:

$$x_i(n) \leq c_i(n) \quad , \quad i = 1, 2, \dots, N \quad , \quad (2.3)$$

$$\sum_{i=1}^N l_i(n) \cdot x_i(n) \leq L_{TOT}(n) \quad , \quad (2.4)$$

where

$c_i(n)$  = production capacity in sector  $i$ ;

$l_i(n)$  = labor-output ratio (labor required to produce a unit of output); and

$L_{TOT}(n)$  = total labor force available.

Equation (2.4) assumes for each sector that labor requirements are proportional to gross production outputs. The production capacity available at any given time period is assumed to be proportional to the total gross fixed capital stock in the corresponding sector at the same time period:

$$c_i(t) = \frac{1}{\beta_i(t)} (K_i(t) + \Delta K_i(t)) \quad , \quad (2.5)$$

where

$\beta_i(t)$  = capital-output ratio in sector  $i$ ;

$K_i(t)$  = fixed capital stock (consisting of durable goods, such as buildings, plants, and machinery) in sector  $i$  at the beginning of time period  $t$ ;

$\Delta K_i(t)$  = new fixed capital stock created in sector  $i$  during time period  $t$ .

By capital-output ratio here we mean average capital-output ratio which is defined as the total (non-depreciated) capital stock divided by total production capacity.

## 2.2. Fixed Capital Stock Dynamics

The dynamics of fixed capital stock over time can be written as follows:

$$K_i(n+1) = K_i(n) + \Delta K_i(n) - \mu_i(n) \cdot K_i(n) \quad , \quad (2.6)$$

where

$\mu_i(n)$  = depreciation factor.

We assume that the depreciation is proportional to the total fixed capital stock of a corresponding sector.

Initial capital stock is given by

$$K_i(1) = K_i^0 \quad . \quad (2.7)$$

The increase in fixed capital stock is a result of construction undertaken a few years before. The following time-lagged equation shows the relationship between construction and increase in fixed capital stock:

$$\Delta K_i(n) = Z_i(n - \tau_i) \quad , \quad (2.8)$$

where

$Z_i(n)$  = new capital stock started to be built up in time period  $n$ ; and

$\tau_i$  = number of time periods corresponding to the construction time in sector  $i$ .

If construction of new capacities in sector  $i$  requires less than  $\Delta t$  years, then  $\tau_i = 0$ . Creation of new fixed capital stock requires investment goods during the whole period of construction. These investment goods are expressed in terms of inputs of goods (or resources) produced by various sectors as follows:

$$I_j^f(n) = \sum_{i=1}^N b_{ji}(n) \cdot Y_i(n) \quad , \quad (2.9)$$

where

$Y_i(n)$  = investment goods used in sector  $i$  at time period  $n$  (capital investment goods by destination);

$b_{ji}(n)$  = share of sector  $j$  in the investment goods required to build up a unit of capital stock in sector  $i$  (during the time period number  $n$ ).

The link between  $Z_i(n)$  and  $Y_i(n)$  is:

$$\Delta K_i(n) = Z_i(n - \tau_i) = \sum_{j=0}^{\tau_i} \alpha_j^i Y_i(n - \tau_i + j) \quad ,$$

with

$\alpha_j^i$  = share of investment goods needed  $j\Delta t$  years after the beginning of construction in sector  $i$ .



Equation (2.9) assumes that the resources required for construction are proportional to a new capital stock to be created and that their amount may vary over the construction time. The rate at which new capital stock is created in each sector is assumed to be limited by the scale of sectoral development, and is equal to a certain share of capital stock available in the same sector. The latter is expressed mathematically as follows:

$$y_i(n) \leq \delta_i(n) \cdot K_i(n) \quad , \quad (2.10)$$

where

$\delta_i$  = the maximal potential growth rate of capital stock.

Introduction of coefficients  $\delta_i$  reflects a certain inertia for capital investment redistribution within national economies; and thus permits a high level of aggregation of economic indicators without necessitating detailed consideration of the quite complicated investment and financial mechanisms causing this inertia.

### 2.3. GNP Bounds

GNP, personal and government consumption levels are considered as scenario inputs, i.e. as exogenous variables, to the model. All these variables describe "desired" or expected states of an economic system over a planning horizon. This means that internal controls (for example, the distribution of goods produced between investment and consumption) should be such that the corresponding economic indicators can in fact approach these desired values.

In this version of the model, this is done as follows. For each time period, upper and lower bounds of GNP are given

$$\frac{|GNP(n) - \widehat{GNP}(n)|}{\widehat{GNP}(n)} \leq \varepsilon(n) \quad , \quad (2.11)$$

where

$\widehat{\text{GNP}}(n)$  given by the GNP level suggested by the scenario;

$\text{GNP}(n)$  the endogenously determined GNP, i.e. the level actually achievable in a consistent and balanced economic development:

$$\text{GNP}(n) = \sum_{i,j=1}^N (1 - a_{ij}(n))x_j(n) \quad , \quad (2.11a)$$

$\epsilon(n)$  the tolerance in approaching target values.

#### 2.4. Personal and Government\* Consumptions

It is assumed that simulated personal and government consumption levels cannot exceed their scenario levels for each time period and for each type of goods produced.

$$w_j^P(n) \leq \widehat{w}_j^P(n) \quad , \quad (2.12)$$

$$w_j^G(n) \leq \widehat{w}_j^G(n) \quad , \quad j = 1, 2, \dots, N \quad , \quad (2.13)$$

where

$\widehat{w}_j^P(n)$  and  $\widehat{w}_j^G(n)$  = given (scenario) personal and government consumptions of product  $j$ .

Instead of using the values on the right-hand sides of (2.12) and (2.13), it is convenient, from the point of view of conventional statistics, to consider certain profiles of personal and government consumption  $\{DP_j(n)\}$  and  $\{DG_j(n)\}$  as well as their totals for each time period  $w_{TOT}^P(n)$  and  $w_{TOT}^G(n)$ .

---

\*The terms used here correspond to private consumption and government expenditure.

By definition, the profiles of final personal or government consumption are vectors whose components are shares of goods in the total consumption, i.e.

$$\sum_{j=1}^N DP_j(n) = 1 \quad , \quad (2.14)$$

$$\sum_{j=1}^N DG_j(n) = 1 \quad . \quad (2.15)$$

Taking into account Equations (2.14) and (2.15), we may substitute new scenario variables  $\{DP_j(n)\}, \{DG_j(n)\}, \hat{W}_{TOT}^P(n), \hat{W}_{TOT}^G(n)$  into the right-hand sides of Equations (2.12) and (2.13). Thus we obtain the following constraints:

$$W_j^P(n) \leq DP_j(n) \cdot \hat{W}_{TOT}^P(n) \quad , \quad (2.16)$$

$$W_j^G(n) \leq DG_j(n) \cdot \hat{W}_{TOT}^G(n) \quad . \quad (2.17)$$

The reason for this substitution is that it is easier for economists to evaluate changes in final consumption profiles and total values of final consumption rather than to predict (absolute) consumption values of goods produced by individual sectors.

We can simplify the model further by assuming that final personal and government consumptions of goods are proportional to their shares in the total consumption, and then consider total final consumption less investment and less net export as a variable in the model: (This is referred to as consumption in the following and is denoted by  $W_j(n)$ .)

$$W_j(n) \leq \hat{W}_j(n) \quad , \quad (2.18)$$

where 
$$W_j(n) = W_j^P(n) + W_j^G(n) \quad , \quad (2.18a)$$

$$\hat{W}_j(n) = DP_j(n) \cdot \hat{W}_{TOT}^P(n) + DG_j(n) \cdot \hat{W}_{TOT}^G(n) \quad . \quad (2.19)$$

For any given  $W_j(n)$  one can easily calculate  $W_j^P(n)$  and  $W_j^G(n)$  as follows:

$$W_j^P(n) = W_j(n) \cdot \lambda_j(n) \quad , \quad (2.20)$$

$$W_j^G(n) = W_j(n) \cdot (1 - \lambda_j(n)) \quad , \quad (2.21)$$

where

$$\lambda_j(n) = \frac{DP_j(n) \cdot \hat{W}_{TOT}^P(n)}{DP_j(n) \cdot \hat{W}_{TOT}^P(n) + DG_j(n) \cdot \hat{W}_{TOT}^G(n)} \quad , \quad (2.22)$$

$$j = 1, 2, \dots, N \quad .$$

## 2.5. Objective Function

We introduce an objective function as follows:

$$F = \sum_{n=1}^T \sum_{j=1}^N W_j(n) \Rightarrow \max \quad . \quad (2.23)$$

Taking into account Equations (2.18a), (2.20) and (2.22), maximization of (2.23) means that the objective of the model is to approach, as closely as possible, but without exceeding their upper bounds, the given final personal and government consumption levels (see Equation 2.18)).

This form of problem statement, i.e., as a problem of the best fit to certain scenario parameters, is advantageous in that the problem as a whole remains one of dynamic linear programming (DLP) (Propoi 1976), which can be solved by conventional LP algorithms or by algorithms that employ characteristics of dynamic constraints (Propoi and Krivonozhko 1978).

Now we can rephrase the problem by excluding all intermediate variables.

## 3. MATHEMATICAL DESCRIPTION OF THE MODEL

All variables are divided into four groups. The first group is one of time independent scenario variables or parameters.

The second group consists of time dependent scenario variables. The third consists of endogenous variables, i.e. variables whose values are being obtained as a result of simulation (solution of the problem). The fourth group consists of all variables, possibly of interest to a modeler, that can easily be calculated on the basis of the variables from the three other groups. We refer to this fourth group of variables as derivatives.

### 3.1. Notation Used in the Model Description

The following notations are used in the basic model description:

#### *Time Independent Exogenous Variables*

$N$  = total number of production sectors;

$T$  = length of a planning horizon (number of time steps);

$\Delta t$  = length of a time step\*;

$K^O = \{K_1^O, K_2^O, \dots, K_N^O\}$  = vector of initial capital stocks;

and

$\tau = (\tau_1, \tau_2, \dots, \tau_N)$  = vector of construction durations (lead times) by sector.

#### *Exogenous Variables*

$A(n) = \| a_{ij}(n) \| (i, j = 1, 2, \dots, N) = N \times N$  matrix of input-output coefficients;

$B(n) = \| b_{ij}(n) \| (i, j = 1, 2, \dots, N) = N \times N$  matrix of capital coefficients;

---

\*One can easily generalize the model with a fixed time step length to one where the time step lengths differ over the planning horizon. For example, the time step length may increase approaching the end of a planning horizon.

$DP(n) = (DP_1(n), DP_2(n), \dots, DP_N(n)) =$  vector of personal consumption profiles,

$$\sum_{i=1}^N DP_i(n) = 1 \quad ;$$

$DG(n) = (DG_1(n), DG_2(n), \dots, DG_N(n)) =$  vector of government consumption profiles,

$$\sum_{i=1}^N DG_i(n) = 1 \quad ;$$

$\alpha_j(n) = (d_j^1(n), d_j^2(n), \dots, \alpha_j^N(n)),$

$j \in [0, \bar{T}] =$  vectors of investment distribution over time,

$\beta(n) = (\beta_1(n), \beta_2(n), \dots, \beta_N(n)) =$  vector of capital-output ratios (gross);

$l(n) = (l_1(n), l_2(n), \dots, l_N(n)) =$  vector of labor-output ratios;

$\mu(n) = (\mu_1(n), \mu_2(n), \dots, \mu_N(n)) =$  vector of depreciation factors;

$\delta(n) = (\delta_1(n), \delta_2(n), \dots, \delta_N(n)) =$  vector of expansion rates; and

$\varepsilon(n) =$  GNP deviation tolerance;

$n = 1, 2, \dots, T =$  index of current time period.

$\widehat{WP}_{TOT}(n) =$  total personal consumption (economic target);

$\widehat{WG}_{TOT}(n) =$  total government consumption (economic target);

$\widehat{GNP}(n) =$  gross national (regional) product (economic target);

$\widehat{L}_{TOT}(n) =$  total labor availability or employment; and

$\widehat{NEXP}(n) = (NEXP_1(n), NEXP_2(n), \dots, NEXP_N(n)) =$  vector of net exports by sector, i.e. export minus import for each type of goods produced.

*Endogenous Variables*

$x(n) = (x_1(n), x_2(n), \dots, x_N(n))$  = vector of gross outputs;

$K(n) = (K_1(n), K_2(n), \dots, K_N(n))$  = vector of capital stocks;

$y(n) = (y_1(n), y_2(n), \dots, y_N(n))$  = vector of additional capital stock under construction; during time period number  $n$ ; and capital investment goods by destination;

$W(n) = (W_1(n), W_2(n), \dots, W_N(n))$  = consumption (personal plus government) vector;

$Z(n) = (Z_1(n), Z_2(n), \dots, Z_N(n))$  = vector of new capacities whose construction is started in period  $n$ .

*Derived Variables ("derivatives")*

$W^P(n) = (W_1^P(n), W_2^P(n), \dots, W_N^P(n))$  = personal consumption vector;

$W^G(n) = (W_1^G(n), W_2^G(n), \dots, W_N^G(n))$  = government consumption vector;

$I^f(n) = (I_1^f(n), I_2^f(n), \dots, I_N^f(n))$  = capital investment (by origin) vector;

$I(n) = (I_1(n), I_2(n), \dots, I_N(n))$  = capital investment (by destination) vector;

$VA(n) = (VA_1(n), VA_2(n), \dots, VA_N(n))$  = vector of value added;

$GNP(n)$  = gross national product;

$WP_{TOT}(n)$  = total personal consumption;

$WG_{TOT}(n)$  = total government consumption;

$NEXP_{TOT}(n)$  = total net export;

$EMP_{TOT}(n)$  = employment;

$K_{TOT}(n)$  = total capital stock;

$KOR(n)$  = overall capital-output ratio; and

$LOR(n)$  = overall labor-output ratio.

### 3.2. Model Equations

#### *Production and Distribution of Goods*

$$x(n) = A(n)x(n) + B(n)y(n) + W(n) + NEXP(n) \quad , \quad (3.1)$$

#### *Capital Constraints*

$$\beta(n)x(n) \leq K(n) + Z(n-\bar{\tau})\Delta t \quad , \quad (3.2)$$

where

$\bar{\tau}$  is used to denote  $\tau_i$  for corresponding  $i = 1, 2, \dots, N$ ,

and

$$Z(n-\bar{\tau}) = \sum_{j=1}^{\bar{\tau}} \alpha_j Y(n-\bar{\tau} + j) \quad ,$$

and

$$\sum_{j=1}^{\bar{\tau}} \alpha_j = 1 \quad .$$

#### *Labor Constraints*

$$l(n)x(n) \leq L_{TOT}(n) \quad , \quad (3.3)$$

#### *Capital Stocks Dynamics*

$$K(n+1) = (I - M(n)) \cdot K(n) + Z_i(n - \tau_i) \quad , \quad (3.4)$$



where

$I$  = the unit  $N \times N$  matrix;

$$M(n) = \| M_{ij}(n) \| (i, j = 1, 2, \dots, N);$$

$$M_{ij}(n) = \begin{cases} \mu_i(n), & \text{if } i = j, \\ 0 & \text{if } i \neq j; \end{cases}$$

*Limits on Capital Stock Formation*

$$y(n) \leq D(n) \cdot K(n) \quad , \quad (3.5)$$

where

$$D(n) = \| D_{ij}(n) \| ,$$

$$D_{ij}(n) = \begin{cases} \delta_i(n), & \text{if } i = j, \\ 0 & \text{if } i \neq j; \end{cases}$$

*Consumption Upper Bounds*

$$W(n) \leq \hat{W}(n) \quad . \quad (3.6)$$

*GNP Upper and Lower Bounds*

$$GNP(n) \leq (1 + \epsilon(n)) \hat{GNP}(n) \quad , \quad (3.7)$$

$$GNP(n) \geq (1 - \epsilon(n)) \hat{GNP}(n) \quad . \quad (3.8)$$

*Planning Horizon*

$$n = 1, 2, \dots, T \quad .$$

*Objective Function*

$$J = \sum_{n=1}^N e \cdot W(n) \quad , \quad (3.9)$$

where

$$e = (1, 1, \dots, 1) = \text{the unit } N \text{ vector.}$$

The following relationships are used to calculate "derivatives".

*Personal Consumption*

$$W_i^P(n) = W_i(n) \cdot \frac{DP_i(n) \cdot \widehat{WP}_{TOT}(n)}{DP_i(n) \cdot \widehat{WP}_{TOT}(n) + DG_i(n) \cdot \widehat{WG}_{TOT}(n)} \quad .$$

*Government Consumption*

$$W_i^G(n) = W_i(n) - W_i^P(n) \quad .$$

*Capital Investment Goods (by origin)*

$$I_j^f(n) = \sum_{i=j}^N b_{ji}(n) \cdot y_i(n) \quad .$$

*Capital Investment Goods (by destination)*

$$I_j(n) = \sum_{i=j}^N b_{ij}(n) \cdot y_j(n) = y_j(n)$$

for

$$\sum_{i=1}^N b_{ij} = 1 \text{ for all } j.$$

*Value Added*

$$VA_i(n) = (1 - \sum_{j=1}^N a_{ji}(n))x_i(n) \quad .$$

*Gross National (Regional) Product*

$$GNP(n) = \sum_{i=1}^N VA_i(n) \quad .$$

*Total Personal Consumption*

$$WP_{TOT}(n) = \sum_{i=1}^N W_i^P(n) \quad .$$

*Total Government Consumption*

$$WG_{TOT}(n) = \sum_{i=1}^N W_i^G(n) \quad .$$

*Total Net Export*

$$NEXP_{TOT}(n) = \sum_{i=1}^N NEXP_i(n) \quad .$$

*Employment*

$$EMP_{TOT}(n) = \sum_{i=1}^N l_i(n) x_i(n) \quad .$$

*Total Capital Stock*

$$K_{TOT}(n) = \sum_{i=1}^N K_i(n) \quad .$$

*Overall Capital-Output Ratio (see Rogner (1977) for definition)*

$$KOR(n) = \frac{K_{TOT}(n)}{GNP(n)} \quad .$$

*Overall Labor-Output Ratio*

$$LOR(n) = \frac{EMP_{TOT}(n)}{GNP(n)} \quad .$$

#### 4. LINKAGE OF INTERLINK TO IIASA'S SET OF ENERGY MODELS

Although the INTERLINK model can be viewed as an independent tool for macroeconomic considerations, a great advantage of its linkage to other models developed in the Energy Systems Program (Häfele and Makarov 1977) is due to the following reasons.

First, a user of INTERLINK does not have to spend time on searching for the specific input information if this information can be provided by other models. Second, phenomena and mechanisms not covered by the INTERLINK structure are treated by other models such as the energy supply model MESSAGE (Agnew, Schrattenholzer, and Voss 1978, 1979), the economy impact model IMPACT (Kononov and Por 1979), and the MACRO model (Rogner 1977). Substituting this information into INTERLINK, one improves the quality of the exogenous inputs to the model and provides consistency among a variety of scenario assumptions for the full set of models.

On the other hand, the information INTERLINK provides on the operation of various industrial sectors is sufficiently detailed to be used in energy demand models. The inputs to these models are thus also improved. This mutual enrichment leads to a multiple cross checking of scenarios and assumptions and final results facilitating better insights into the general problem under investigation.

The following is a general description of the link between INTERLINK and other models in IIASA's set of energy models.

#### 4.1. Linkage to the MACRO Model

The following MACRO output variables are used as inputs to INTERLINK:

- $\tilde{G}NP$  = gross regional (national) product;
- $\tilde{W}P_{TOT}$  = total personal consumption;
- $\tilde{W}G_{TOT}$  = total government consumption;
- $\tilde{L}_{TOT}$  = total labor availability (employment); and
- $\tilde{P}R$  = growth rate of labor productivity.

In MACRO all these variables are dynamic, i.e. their average yearly values are used. At the same time INTERLINK uses yearly averages of these values over a given time step  $\Delta t$  as endogenous upper bounds. MACRO variables can also be measured in different monetary units. For instance, depending on basic information sources, INTERLINK may operate with all variables in \$ 1967 as opposed to MACRO whose variables are in \$ 1972. Thus, the inputs to be provided from MACRO to INTERLINK should be recalculated as follows:

$$\widehat{G}NP(n) = \frac{\Delta p}{\Delta t} \sum_{s=(n-1)\Delta t+1}^{n \cdot \Delta t} \tilde{G}NP(s) \quad , \quad (4.1)$$

$$\widehat{W}P_{TOT}(n) = \frac{\Delta p}{\Delta t} \sum_{s=(n-1)\Delta t+1}^{n \cdot \Delta t} \tilde{W}P_{TOT}(s) \quad , \quad (4.2)$$

$$\widehat{W}G_{TOT}(n) = \frac{\Delta p}{\Delta t} \sum_{s=(n-1)\Delta t+1}^{n \cdot \Delta t} \tilde{W}G_{TOT}(s) \quad , \quad (4.3)$$

$$\hat{L}_{TOT}(n) = \frac{1}{\Delta t} \sum_{s=(n-1)\Delta t+1}^{n \cdot \Delta t} \tilde{L}_{TOT}(s) \quad , \quad (4.4)$$

$$\hat{PR}(n) = \frac{1}{\Delta t} \sum_{s=(n-1) \cdot \Delta t+1}^{n \cdot \Delta t} \tilde{PR}(s) \quad , \quad (4.5)$$

$$l_i(n+1) = \frac{l_i(n)}{(1+PR(n) \cdot \Delta t)} \quad , \quad i = 1, 2, \dots, N \quad , \quad (4.6)$$

$$n = 1, 2, \dots, T \quad , \quad (4.7)$$

$$s = 1, 2, \dots, \tilde{T} \quad ,$$

$$\tilde{T} = T/n \quad , \quad (4.8)$$

where

$\Delta p$  = multiplier converting monetary units used in MACRO to those used in INTERLINK;

$s$  = "current time period" (number of a time period) in MACRO;

$n$  = "current time period" (number of a time period) in INTERLINK; and

$\tilde{T}$  = length of a planning horizon in MACRO (total number of time periods).

All waved variables are MACRO outputs, and roofed variables are direct inputs to INTERLINK. Calculations (4.1) to (4.8) have to be done by a certain "post-run" procedure called TRANSLATOR 1 (see Figure 3). Similar TRANSLATOR concepts are used in the other model links.

The discrepancies between final consumption and employment generated by MACRO and calculated by "post-run" INTERLINK TRANSLATOR 2 are fed back from INTERLINK to MACRO. These variables are calculated in the INTERLINK model and converted to MACRO variables as follows:

$$\Delta \tilde{WP}_{TOT}(s) = \tilde{WP}_{TOT}(s) - WP_{TOT}(n)/\Delta p \quad , \quad (4.9)$$

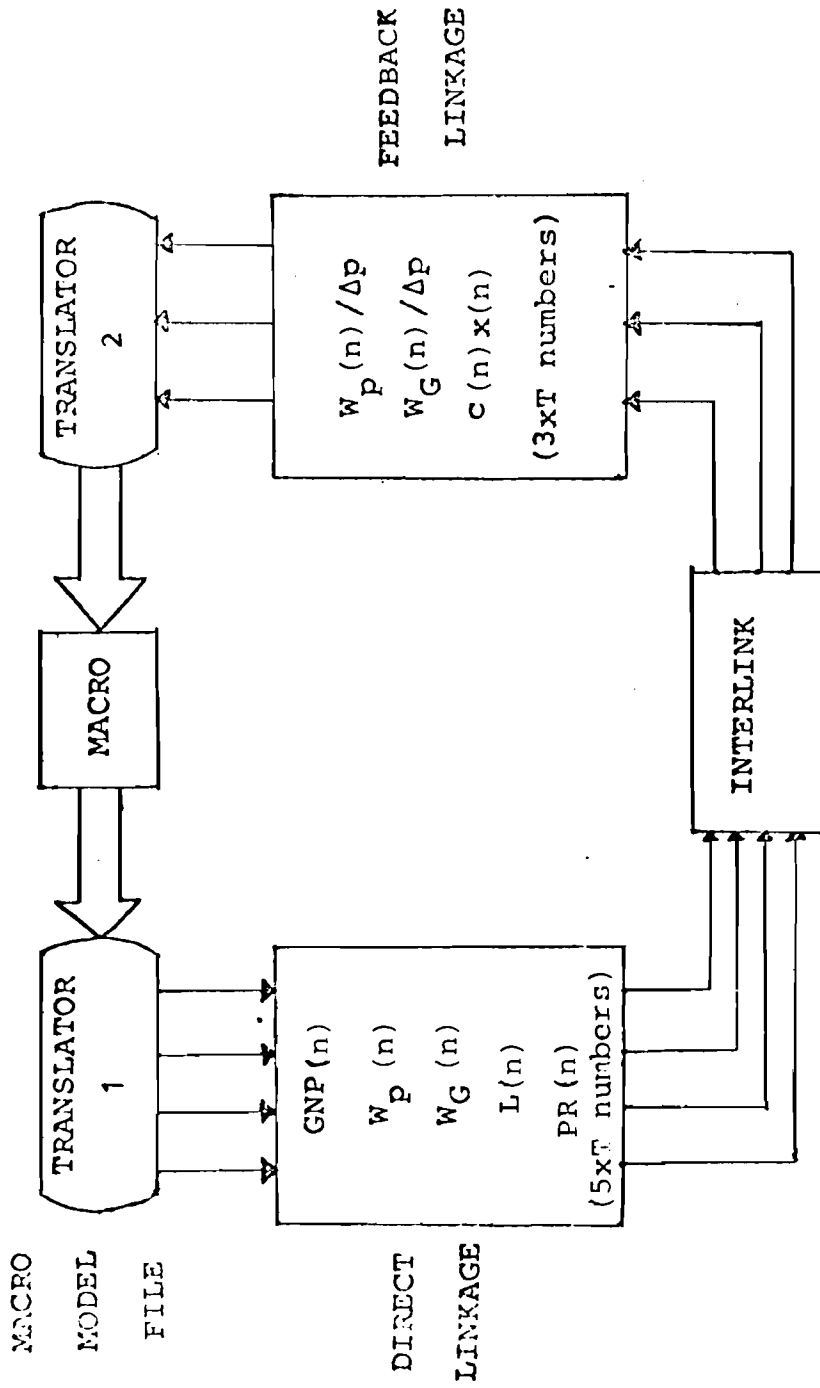

Figure 3. Linkage of MACRO and INTERLINK.

$$\Delta \tilde{W}_{TOT}(s) = \tilde{W}_{TOT}(s) - W_{TOT}(n) / \Delta p \quad , \quad (4.10)$$

$$\tilde{\Delta L}_{TOT}(s) = \tilde{L}_{TOT}(s) - l(n) \cdot x(n) \quad , \quad (4.11)$$

$$s = (n - 1) \cdot \Delta t + 1, \dots, n \cdot \Delta t \quad , \quad (4.12)$$

$$n = 1, 2, \dots, T \quad ,$$

where

$$W_{TOT}(n), W_{TOT}(n), x(n) = \text{INTERLINK outputs.}$$

Equations (4.9) to (4.11) describe the internal structure of TRANSLATOR 2 in Figure 3. The figure also illustrates the volume of information exchange between the two models.

#### 4.2. Linkage to the MUSE Model

The inputs to MUSE from the INTERLINK model are:

value added by sector

$$VA_i(n), \quad i = 1, 2, \dots, N \quad ;$$

energy demand patterns per end-use categories

$$\delta_{pi}(n), \quad i = 1, 2, \dots, N \quad ,$$

$$p \in P \quad ;$$

with

$$P = \{\text{process heat, space heat, air conditioning, electric power}\};$$

and energy intensiveness of industrial sectors

$$E_i(n), \quad i = 1, 2, \dots, N \quad ,$$

$$n = 1, \dots, T \quad .$$



The value added is calculated by the INTERLINK "post-run" procedure and is converted into corresponding MUSE monetary units as follows:

$$VA_i(n) = \Delta p_i \cdot \left(1 - \sum_{j=1}^N a_{ji}(n)\right) x_i(n) \quad . \quad (4.13)$$

Energy demand patterns per end-use categories are calculated as relative shares of intermediate energies consumed by industrial sectors:

$$\delta_{pi}(n) = \frac{x_{pi}(n)}{\sum_{p \in P} x_{pi}(n)} = \frac{a_{pi}(n) \cdot x_i(n)}{\sum_{p \in P} a_{pi}(n) \cdot x_i(n)} = \frac{a_{pi}(n)}{\sum_{p \in P} a_{pi}(n)} \quad , \quad (4.14)$$

$$i = 1, 2, \dots, N; \quad n = 1, \dots, T. \quad (4.15)$$

The energy intensiveness by sector is calculated as a ratio of total energy consumed by this sector to value added:

$$E_i(n) = \frac{\sum_{p \in P} a_{pi}(n) \cdot x_i(n)}{\Delta \cdot VA_i(n)} \quad , \quad i = 1, 2, \dots, N, \quad (4.16)$$

where

$\Delta$  = coefficient converting BTU into kWh.

The data transferred to MUSE have to be interpolated on a year-by-year basis (other than in INTERLINK using yearly averages for each  $\Delta t$ ). This is done as follows:

$$VAD_i(s) = VA_i(n) \quad , \quad (4.17)$$

$$\delta_{pi}(s) = \delta_{pi}(n) \quad , \quad (4.18)$$

$$E_i(s) = E_i(n) \quad , \quad (4.19)$$

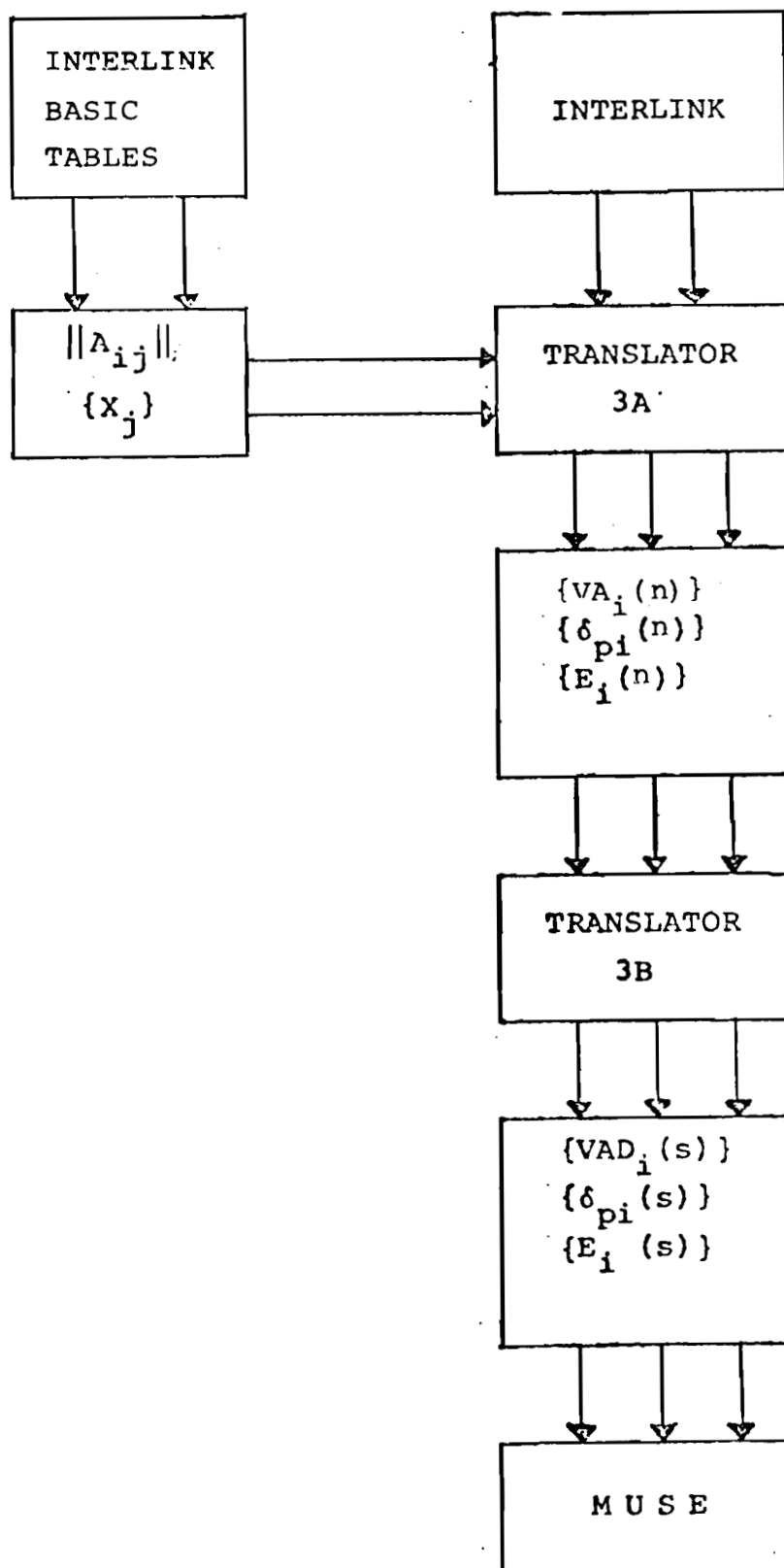

Figure 4. Linkage of INTERLINK and MUSE.

$$(n - 1)\Delta t + 1 \leq s \leq n \cdot \Delta t \quad ,$$

$$n = 1, \dots, T \quad ,$$

$$s = 1, 2, \dots, T \cdot \Delta t$$

where

$n$  = "index at current time period" in INTERLINK; and

$s$  = "current time period" in MUSE.

Calculations (4.13) to (4.16) and (4.17) to (4.19) combine two blocks (TRANSLATOR 3A and TRANSLATOR 3 B) of an INTERLINK-MUSE TRANSLATOR (see Figure 4).

#### 4.3. Linkage to the MEDEE-2 Model

The following INTERLINK outputs are used as inputs to the MEDEE-2 model:

GNP(n) = gross national (regional) product;  
 $I_{TOT}(n)$  = total investment;  
 $WP_{TOT}(n)$  = total personal consumption;  
 $WG_{TOT}(n)$  = total government consumption;  
VA(n) = value added by sector;  
I(n) = investment by sector;  
 $W^P(n)$  = personal consumption by sector;  
 $W^G(n)$  = government consumption by sector; and  
x(n) = gross outputs by sector;  
 $i = 1, 2, \dots, N; \quad n = 1, \dots, T.$

Value added data are used in the MEDEE-2 model for the following sectors, in order to derive their useful or specific energy demand levels:

1. Intermediary goods industries;
2. Equipment goods industries;
3. Nondurable consumer goods industries;
4. Miscellaneous industries;

5. Construction industries;
6. Mining industries; and
7. Agriculture.

For each of the MEDEE-2 sectors, the value added is derived from INTERLINK data as follows:

$$\tilde{VA}_j(n) = \sum_{i \in J_j} VA_i(n), \quad j = 1, 2, \dots, M, \quad (4.20)$$

where

$\tilde{VA}_j(n)$  = the value added in MEDEE-2 sector  $j$  in time period  $t$ ;

$J_j$  = the set of INTERLINK sectors to be aggregated into MEDEE-2 sector  $j$ ; and

$M$  = the total number of industrial sectors in MEDEE-2 (in the MEDEE-2 model  $M = 7$ ).

The value added is used to calculate the useful or specific energy demand in a given year:

$$PROC_p(n) = \sum_{i=1}^M \tilde{VA}_i(n) \cdot EIO_{i,p} \cdot EIRATE_p, \quad (4.21)$$

$$p \in P, \quad (4.22)$$

where

$PROC_p(n)$  = the final energy demand for process  $p$ ;

$EIO_{i,p}$  = the specific energy requirements in sector  $i$  for process  $p$  in a future time period relative to the base year; and

$P$  = the total set of different energy processes considered in the MEDEE-2 model.

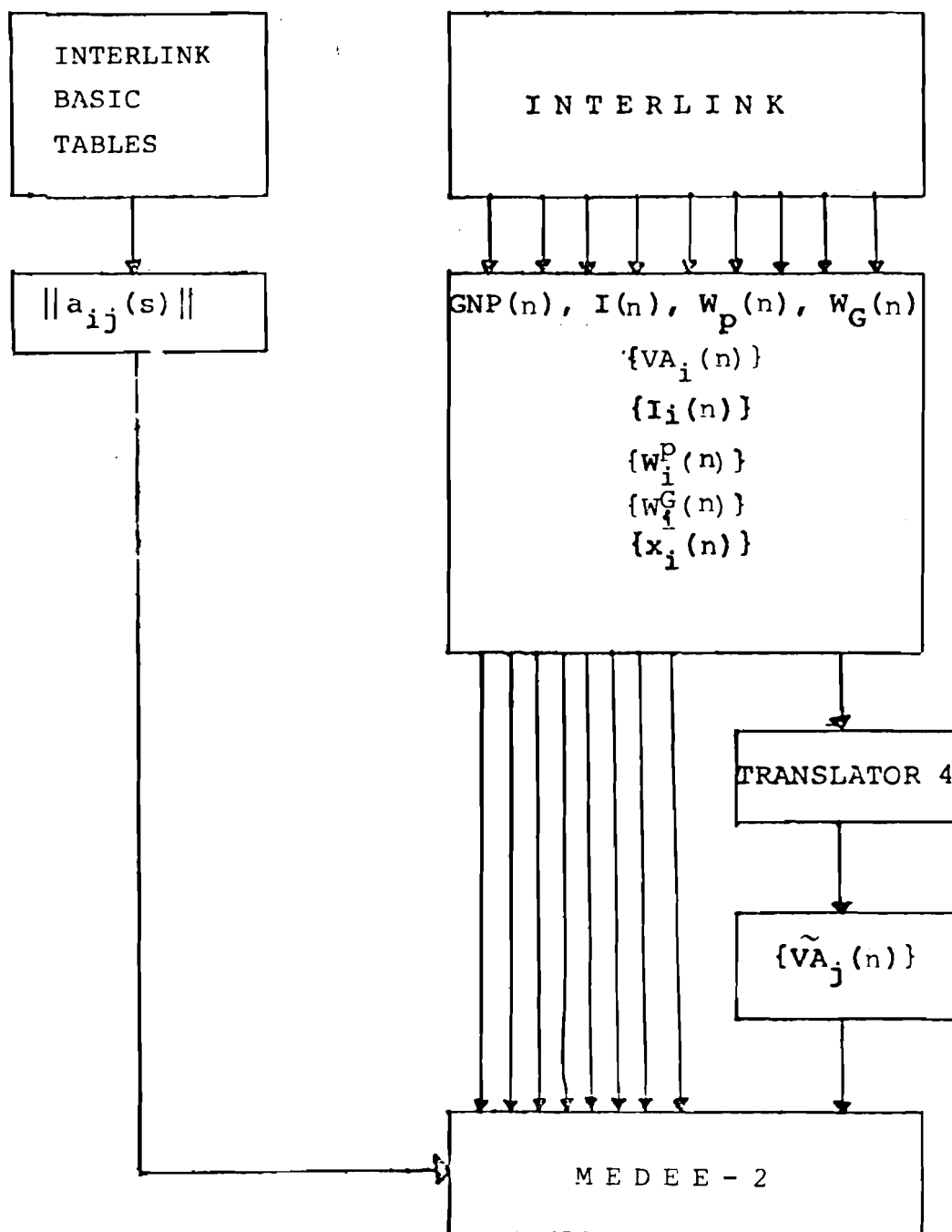

Figure 5. Linkage of INTERLINK and MEDEE-2.

In the case of MEDEE-2 this set P consists of the following processes:

1. steam generation;
2. furnaces;
3. space heating;
4. specific use of electricity (electrolysis, motive power, lighting); and
5. motor fuel.

Although, in general the aggregated MEDEE-2 sectors are considered, more detailed information is used to estimate the effect on the energy intensiveness resulting from changes on the composition of these aggregates. The linkage scheme of INTERLINK and MEDEE-2 is shown in Figure 5. Relationship (4.20) describes internal calculations in TRANSLATOR 4.

#### 4.4. Linkage to the IMPACT Model

INTERLINK is linked to IMPACT through direct costs, direct investment, and direct manpower required to implement an energy system development strategy. This strategy is determined by the MESSAGE model. The linkage, which is of a feedback type, takes effect after the full iteration of both MESSAGE and IMPACT.

The sectoral representation in IMPACT is more disaggregated than that in INTERLINK, both in the energy sectors and in the nonenergy sectors. Thus direct costs, direct investment, and direct manpower requirements of the energy sectors have to be aggregated first in the IMPACT model file, and in this form be transferred to INTERLINK. This is the essence of the IMPACT-INTERLINK TRANSLATOR (or TRANSLATOR 5), the formal description of which is given below.

Let

$DC_i(n)$  be direct costs in time period  $n$ , i.e. the direct requirement of energy sectors in terms of the products of the nonenergy sector  $i$  in the nomenclature of INTERLINK sectors;

$DI_j(n)$  be direct investments to energy sector  $j$  in the INTERLINK model; and

$DM(n)$  be direct manpower requirements.

These values are being calculated as follows:

$$\begin{aligned}
 DC_i(n) = \Delta p \cdot \sum_{k \in I_i} \left( \sum_{e \in E^{IMP}} A_{ke} \cdot X_e(n) \right. \\
 \left. + \sum_{e \in E^{IMP}} \sum_{\tau=n}^{n+\tau_i} F_{ke}^{n\tau} \cdot Z_e(\tau) \right) , \quad (4.23) \\
 i = 1, 2, \dots, N ,
 \end{aligned}$$

$$DI_j(n) = \Delta p \cdot \sum_{e \in E_j} INV_e(n) , \quad (4.24)$$

$$j \in E ,$$

and

$$DM(n) = \sum_{e \in E^{IMP}} MP_e(n) , \quad (4.25)$$

where

$I_i$  = the IMPACT model's sectors corresponding to INTERLINK's aggregated sector  $i$ ;

$E^{IMP}$  = the set of IMPACT energy sectors;

$A_{ij}$  = the input-output coefficients in the IMPACT model;

$X_i$  = the gross output (annual averaged over time period  $\Delta t$ ) of sector  $i$  in the IMPACT model;

$F_{ke}^{t\tau}$  = capital coefficients of the IMPACT model;

$Z_e(n)$  = expansion of capacities in sector  $e$  of the IMPACT model;

$E_j$  = the set of IMPACT energy sectors represented by (aggregated) energy sector  $j$  in INTERLINK;

$E$  = the set of energy sectors in INTERLINK;

$INV_e$  = the direct investment to IMPACT's energy sector e; and

$MP_e$  = the direct manpower requirements in IMPACT's energy sector e.

The linkage between the two models is depicted in Figure 6.

In order to link IMPACT and INTERLINK, the latter would have to be slightly modified by substitution of direct inputs from IMPACT for the corresponding endogenous variables in INTERLINK. To describe these modifications let us first rewrite Equations (3.1) and (3.4) and constraints (3.3) by dividing the INTERLINK production system into energy (E) and nonenergy (NE) sectors.

$$X_E(n) = A_E^E(n)X_E(n) + A_{NE}^E(n)X_{NE}(n) + W_E(n) + NEXP_E(n) \quad , \quad (4.26)$$

$$X_{NE}(n) = A_E^{NE}(n)X_E(n) + A_{NE}^{NE}(n)X_{NE}(n) + I_{NE,E}^f(n) + I_{NE,NE}^f(n) + W_{NE}(n) + NEXP_{NE}(n) \quad , \quad (4.27)$$

$$K_E(n+1) = (I - D_E(n))K_E(n) + \Delta K_E(n) \quad , \quad (4.28)$$

$$K_{NE}(n+1) = (I - D_{NE}(n))K_{NE}(n) + \Delta K_{NE}(n) \quad , \quad (4.29)$$

where we use notation  $\Delta K_i(n) = Z_i(n - \tau_i)$ ,  $i = E, NE$  ,

$$l_E(n) \cdot X_E(n) + l_{NE}(n) \cdot X_{NE}(n) \leq L_{TOT}(n) \quad , \quad (4.30)$$

By definition we have the following relationships (see (4.24) to (4.25)).



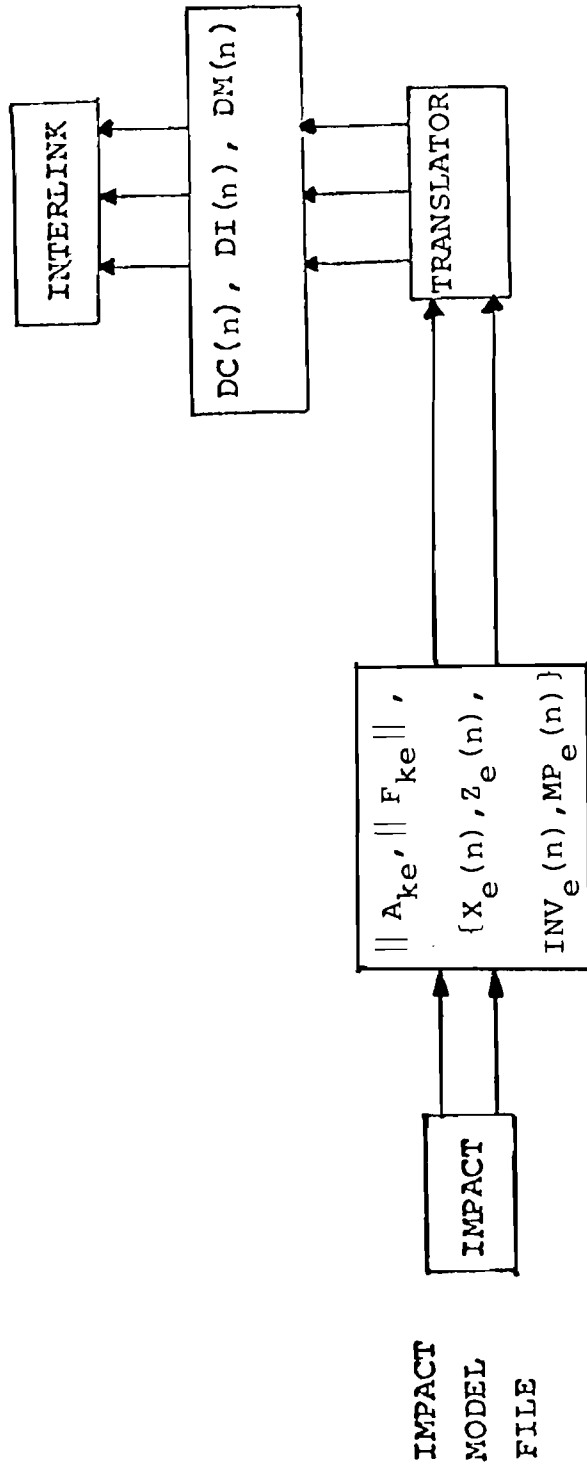

Figure 6. Linkage of IMPACT and INTERLINK.

$$DC(n) = A_E^{NE}(n)X_E(n) + I_{NE,E}^f(n) \quad , \quad (4.31)$$

$$DI(n) = \Delta K_E(n) \quad , \quad (4.32)$$

$$DM(n) = l_E(n)X_E(n) \quad . \quad (4.33)$$

Substituting DC(n), DI(n) and DM(n) into equations (4.27), (4.28) and (4.30) we obtain a modified INTERLINK model where these variables are exogenous inputs from IMPACT:

$$X_{NE}(n) = A_{NE}^{NE}(n) \cdot X_{NE}(n) + I_{NE,NE}^f(n) + W_{ME}(n) + NEXP_{NE}(n) + \underline{DC}(n) \quad , \quad (4.27A)$$

$$K_E(n+1) = (I - D_E(n))K_E(n) + \underline{DI}(n) \quad , \quad (4.28A)$$

$$\underline{DM}(n) + L_{NE}(n) \cdot X_{NE}(n) \leq L_{TOT}(n) \quad , \quad (4.30A)$$

All other equations and inequalities of the INTERLINK model do not change.

## 5. COMPUTERIZATION OF THE MODEL

The computerization of the INTERLINK model has been done by W. Orchard-Hays and the author. An earlier version of the model (PI model) was programmed by N. Burova for preliminary analysis and testing. Details of programming, generating, and running of the model as well as "post-run" analysis of solutions can be found in Chapter 9 of Orchard-Hays (forthcoming)\*. Here the model is described as a conventional LP problem with the various subsystems represented in tabular form.

---

\*The main computer programs and data files on INTERLINK existing at IIASA are:

- program files in the SESAMI environment called ILKINDSH DATARUN, ILKINIT DATARUN, ILKINPUT MPFILE, and ILKMACS DATAMAC; and
- data files under ILKXOO DATA, ILKX67 DATA, and ILKX85 DATA.

VARIABLES:

X

Y

K

W

OBJECTIVE FUNCTION	PRODUCTION	CAPITAL FORMATION	CAPITAL STOCK	CONSUMPTION	TYPE OF CONSTRAINT	RIGHT-HAND SIDES
DEMAND CONSTRAINTS (3.1)	0	0	0		=	
AVAILABILITY OF CAPACITY (3.2)				0	≤	0
CAPITAL STOCK DYNAMICS (3.4)	0			0	=	
EXPANSION LIMITS (3.5)	0			0	≤	0
CONSUMPTION UPPER BOUNDS (3.6)	0	0	0		≤	
LABOR AVAILABILITY (3.3)		0	0	0	≤	
GNP RANGES (3.7), (3.8)		0	0	0	≤	
PROGRAM NAME:	GENPROD	GENEXP	GENCAP	GENCONS		GENRHS

Figure 7. LP matrix of the INTERLINK model.

The LP matrix is generated in parts that correspond to the following basic activities described by the model: production, construction or accumulation of capital stock, capital stock dynamics, and total consumption. All these parts are generated for all time periods, and the LP matrix rows are divided into categories corresponding to qualitatively different types of constraints. The complete LP matrix is shown in Figure 7. Below we describe components or parts of this matrix that correspond to different submodels. Note that right-hand sides are to be added containing the following inputs: capacities (capital stock) construction of which started in a preliminary period (say in time period 0 or -1) and IMPACT direct costs, direct manpower requirements. The latter should be subtracted from INTERLINK's right-hand sides.

Table 1. Submodel GENFROD simulating production; the model variable is gross outputs (x).

Constraint	Type of constraint	Model equation	Dimension (number of rows)
(i) demand	equality	(3.1)	N x T
(ii) capacity availability	inequality ( $\leq$ )	(3.2)	N x T
(iii) labor availability	inequality ( $\leq$ )	(3.3)	1 x T
(iv) GNP ranges	inequality ( $\leq$ )	(3.7), (3.8)	2 x T
Total number of rows			= (2N+3) x T
Total number of columns			= N x T

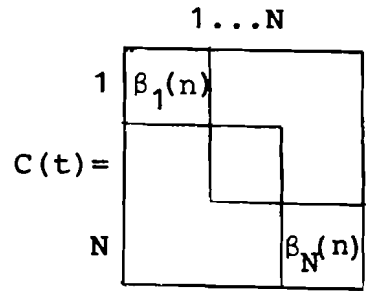
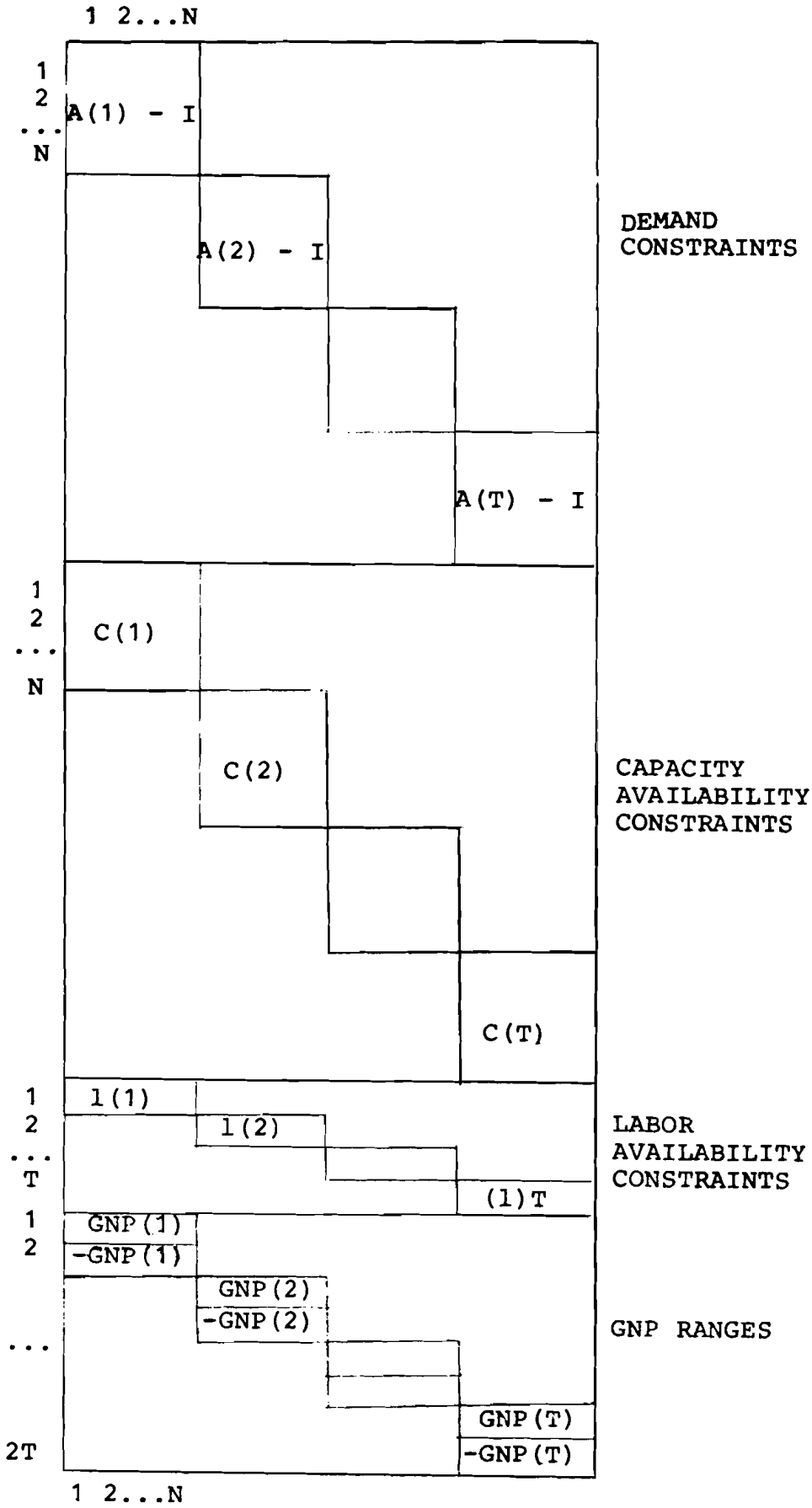
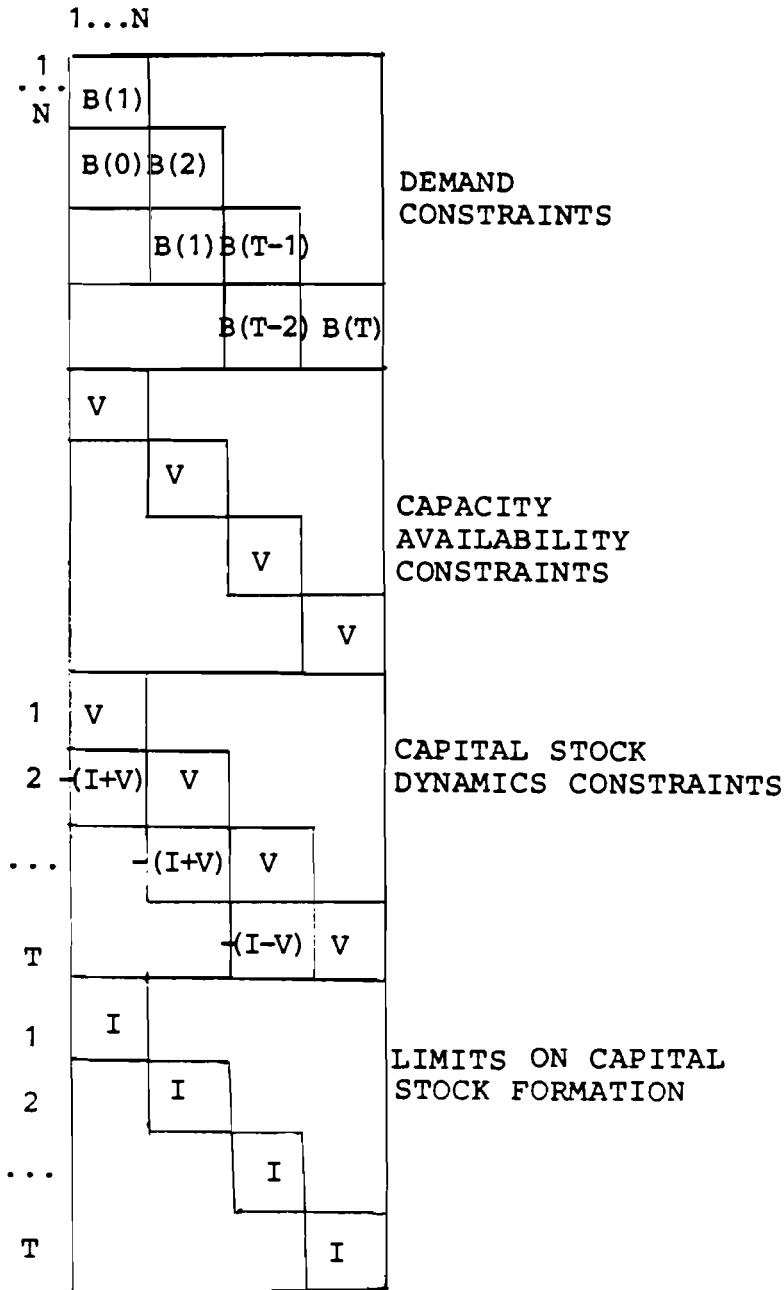

Figure 8. GENPROD submodel matrix.



$$N = N_0 \cup N_1, \quad \tau_i = \begin{cases} 0, & \text{if } i \in N_0, \\ 1, & \text{if } i \in N_1; \end{cases}$$

$$V = \|v_{ij}\|_{i,j=1,2,\dots,N}; \quad v_{ij} = \begin{cases} 0, & \text{if } i \neq j, \\ -\Delta t, & \text{if } i = j \text{ and } i \in N_0; \end{cases}$$

I = unit matrix NxN

Figure 9. GENEXP submodel matrix.

Table 2. Submodel GENEXP simulating construction; the model variable is capital stock formation (Y).

Constraint	Type of constraint	Model equation	Dimension (number of rows)
(i) demand	equality	(3.1)	$N \times T$
(ii) capacity availability	inequality ( $\leq$ )	(3.2)	$N \times T$
(iii) capital stock dynamics	equality	(3.4)	$N \times (T-1)$
(iv) limits on capital stock formation	inequality ( $\leq$ )	(3.5)	$N \times T$
Total number of rows			= $(4N-1) \times T$
Total number of columns			= $N \times T$

Table 3. Submodel GENCAP simulating capital stock depreciation and accumulation; the model variable is capital stock (K).

Constraint	Type of constraint	Model equation	Dimension (number of rows)
(i) capacity availability	inequality ( $\leq$ )	(3.2)	$N \times T$
(ii) capital stock dynamics	equality	(3.4)	$N \times (T-1)$
(iii) expansion limits	inequality ( $\leq 0$ )	(3.5)	$N \times T$
Total number of rows			= $N \times (3T-1)$
Total number of columns			= $N \times T$

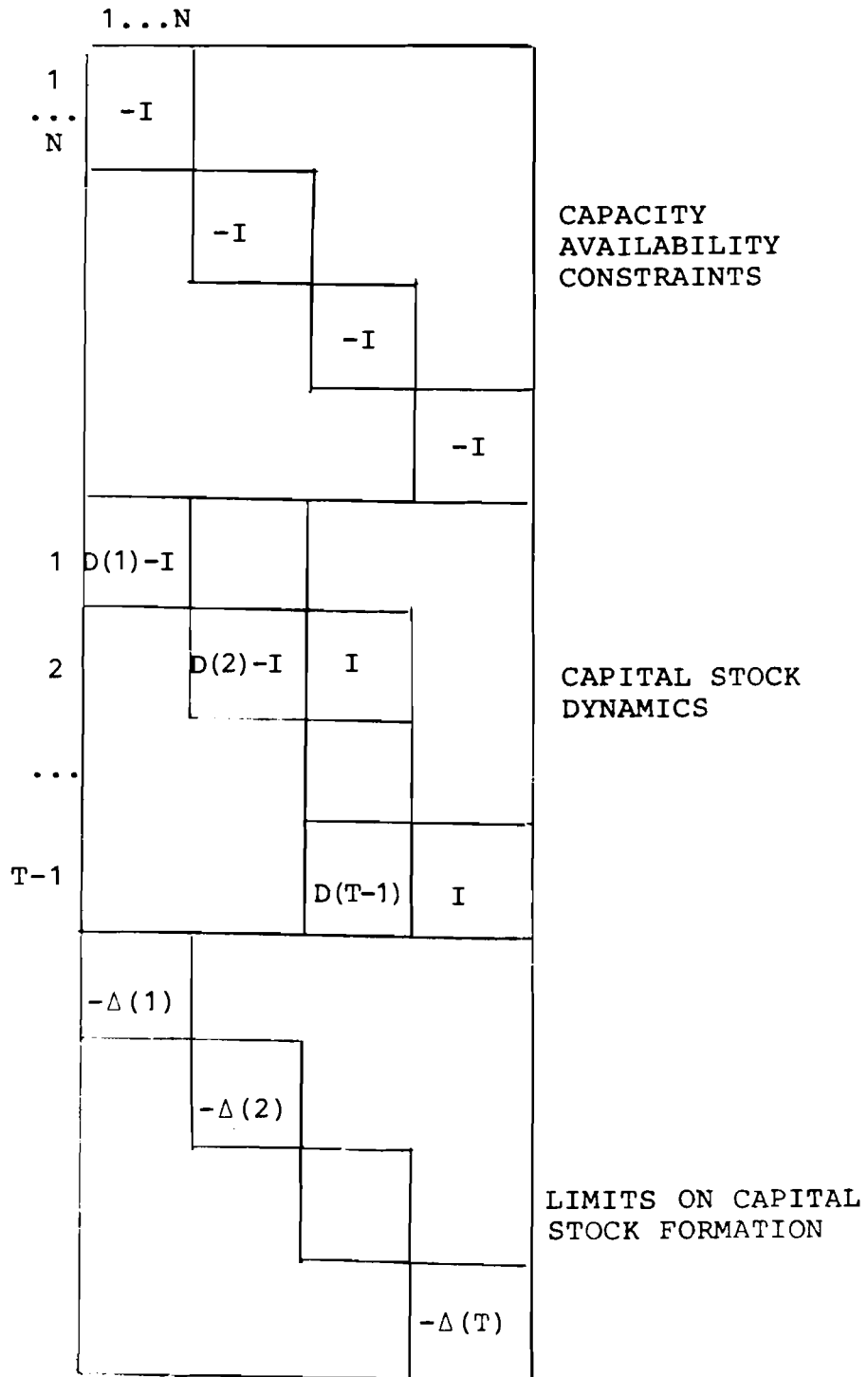

Figure 10. GENCAP submodel matrix.



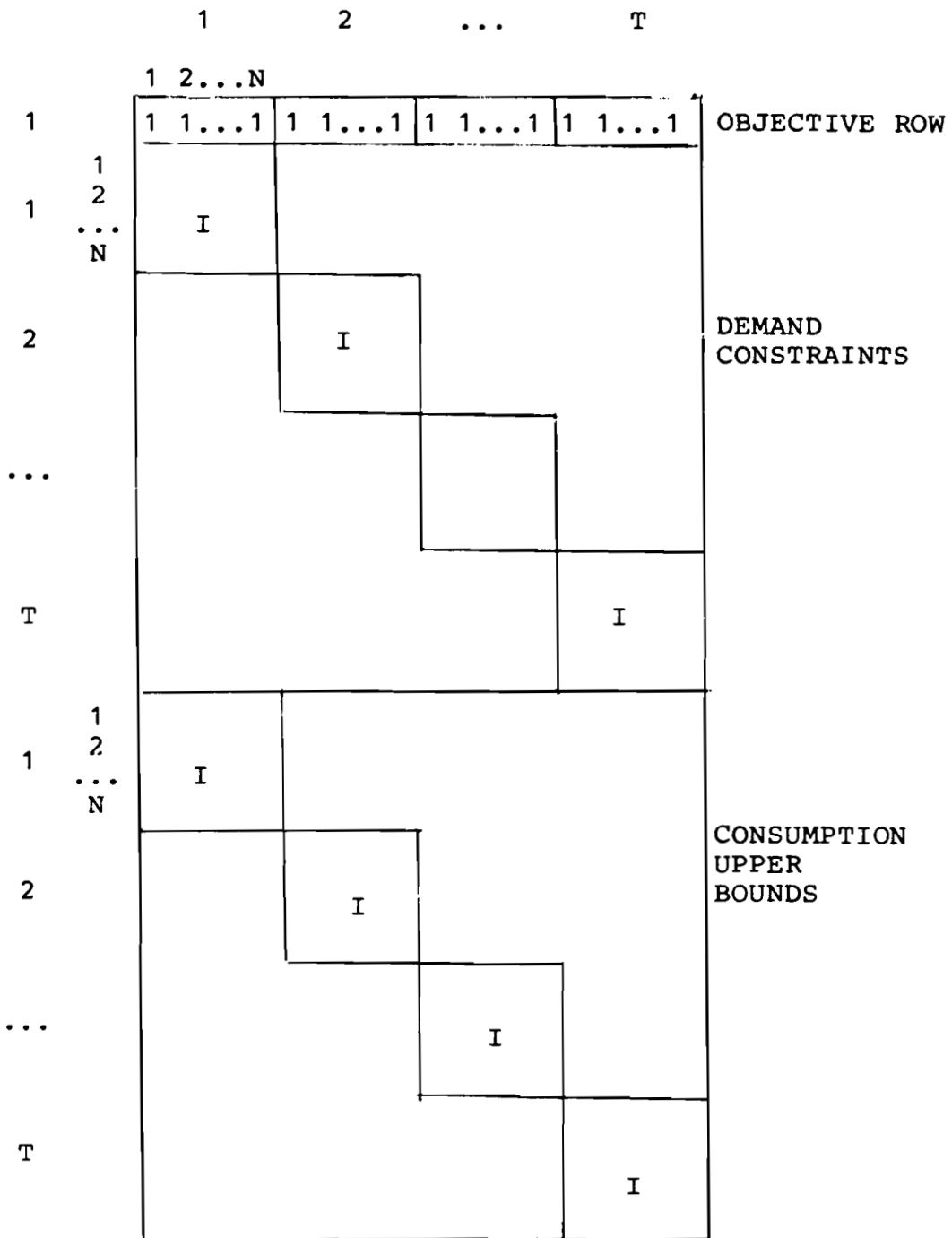
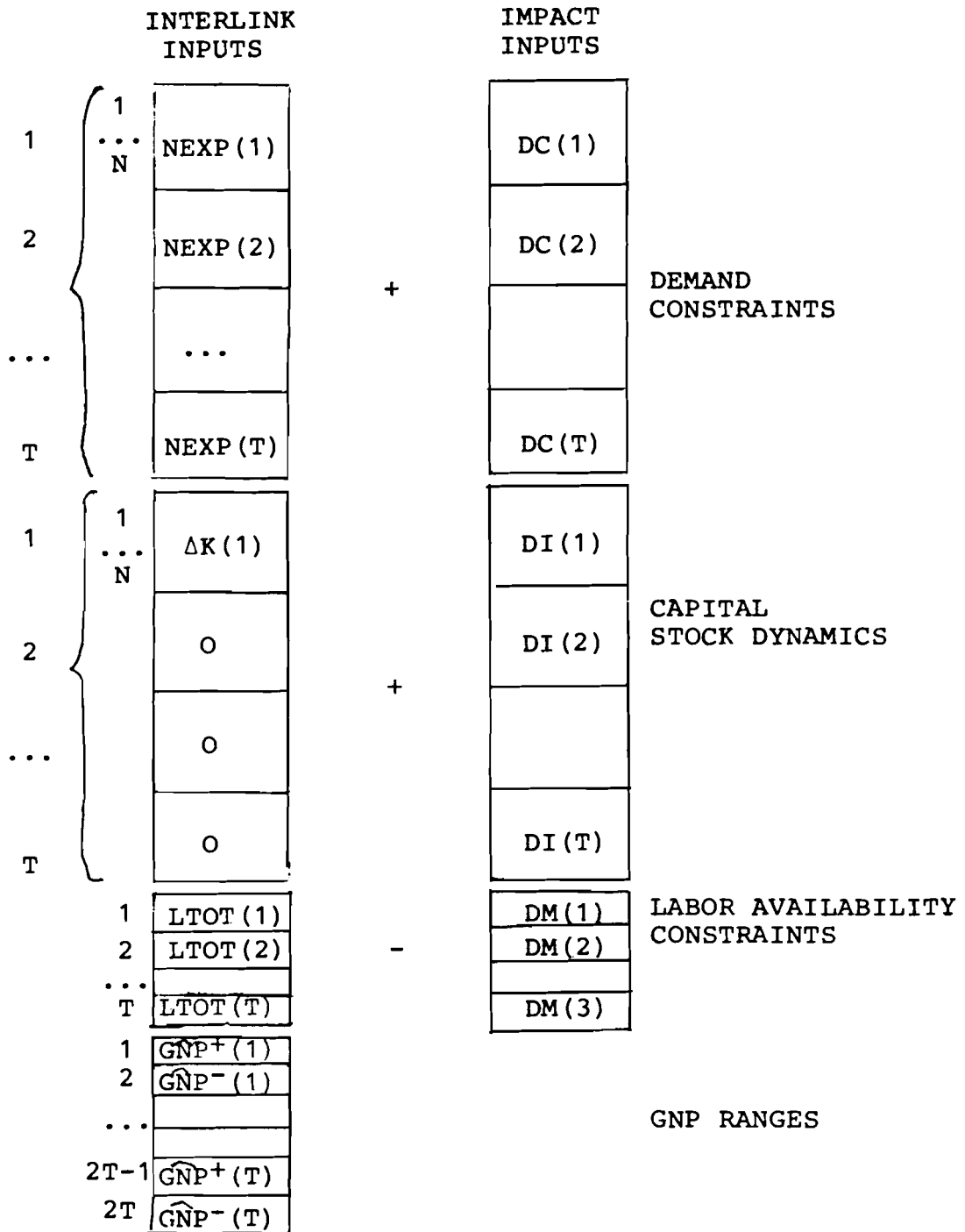

Figure 11. GENCONS submodel matrix.



$$\widehat{GNP}^+ = (1 + \epsilon(n)) GNP(n)$$

$$\widehat{GNP}^- = (1 - \epsilon(n)) GNP(n)$$

Figure 12. GENRHS submodel matrix.

Table 4. Submodel GENCONS simulating consumption; the model variable is consumption (W).

Constraint	Type of constraint	Model equation	Dimension (number of rows)
(i) demand	equality	(3.1)	$N \times T$
(ii) consumption upper bounds	inequality ( $\leq$ )	(3.6)	$N \times T$
Total number of rows			= $2N \times T$
Total number of columns			= $N \times T$

Table 5. Submodel GENRHS for the right-hand side exogenous inputs;

Constraint	Type of constraint	Model equation	Dimension (number of rows)
(i) demand	equality	(3.1)	$N \times T$
(ii) capital stock dynamics	equality	(3.4)	$N \times (T-1)$
(iii) labor availability	inequality ( $\leq$ )	(3.3)	$1 \times T$
(iv) GNP ranges	inequality ( $\leq$ )	(3.7), (3.8)	$1 \times T$

### 5.1. Dimensions of the LP Problem

$$\begin{aligned} \text{Total number of rows} &= (5N + 3)T - N + 1 \\ &\quad \text{(including objective row)} \end{aligned}$$

$$\begin{aligned} \text{Total number of columns} &= 4N \cdot T + 1 \\ &\quad \text{(including right-hand sides)} \end{aligned}$$

Note that upper bounds and ranges are not usually counted in calculating the dimensions of an LP problem. Taking this into consideration we obtain the following estimates for the BASIC INTERLINK LP problem:

$$N_{\text{rows}} = (4N + 1)T - N + 1 \quad , \quad (5.1)$$

$$N_{\text{columns}} = 4N \cdot T + 1 \quad .$$

In the case of  $N = 17$  and  $T = 12$ , (5.1) gives the following estimates:

$$N_{\text{rows}} = 812$$

$$N_{\text{columns}} = 817$$

The density of cases of model application of the LP matrix was about 1%.

## 6. THE U.S. BASE CASE, AN ILLUSTRATIVE EXAMPLE

The application of INTERLINK is illustrated by simulation of the potential of the development of the U.S. economy for the period of 1975-2035.

The U.S. economy is represented by 17 production sectors. Dynamic input-output tables are obtained by aggregation and interpolation of BNL input-output tables provided for 110 sectors and for the years 1967, 1985, and 2000 (Behling et al. 1975). The correspondence of INTERLINK and BNL sectors is shown in Table 6. Final consumption profiles are estimated on the basis of BNL data and the life-style scenarios considered in MUSE.

Table 6. Correspondence of production sectors in INTERLINK and BNL

INTERLINK sectors	BNL sectors numbers
1. ELECTRICITY	8, 9, 10, 11, 12
2. NONELECTRICITY (FUEL)	1, 2, 3, 4, 5, 6, 7
3. FERROUS METALS	25, 61
4. NONFERROUS METALS	26, 62
5. BUILDING MATERIALS	27, 59, 60
6. CHEMICAL, PLASTICS AND ALLIED PRODUCTS	28, 50, 51, 52, 53, 54, 55, 56
7. METAL PRODUCTS	63, 64, 65, 66
8. MACHINERY AND EQUIPMENT	67, 68, 69, 70, 71, 72, 73, 74, 75, 76, 77, 78, 79, 80, 81, 82, 86, 87
9. TRANSPORTATION EQUIPMENT	83, 84, 85
10. PAPER AND ALLIED PRODUCTS	47, 48, 49
11. TEXTILES, CLOTHING, LEATHER PRODUCTS	39, 40, 41, 42, 57, 58
12. FOOD PRODUCTS	37, 38
13. MISCELLANEOUS MANUFACTURING	36, 43, 44, 45, 46, 88
14. AGRICULTURE	21, 22, 23, 24
15. CONSTRUCTION AND MAINTENANCE	29, 30, 31, 32, 33, 34, 35
16. TRANSPORTATION	89, 90, 91, 92, 93, 94, 95
17. SERVICES, COMMUNI- CATIONS AND OTHER	96, 97, 98, 99, 100, 101, 102, 103, 104, 105, 106, 107, 108, 109, 110

These profiles as well as the capital-output ratios are dynamic. Capital-output, labor-output ratios, depreciation factors, and initial capital stock were obtained from studies on capital and labor intensiveness of U.S. industries and updated on the basis of recent statistical data (U.S. Department of Commerce 1974, 1975). Scenario projections of total personal and government consumption, GNP, labor availability, and labor productivity were provided by the MACRO model. These projections correspond to the U.S. base case scenario assumptions developed in IIASA's Energy Systems Program (Doblin 1977).

Some simulation results are given here in order to compare them to other projections (Behling et al. 1975, U.S. Department of Commerce 1975). The following figures are polynomial approximations of the INTERLINK solutions for GNP, total investment, total personal consumption, total government consumption, total capital stock, employment, and gross outputs of some of the industrial sectors listed in Table 6 above. Results available from other studies are provided for the purpose of comparison.

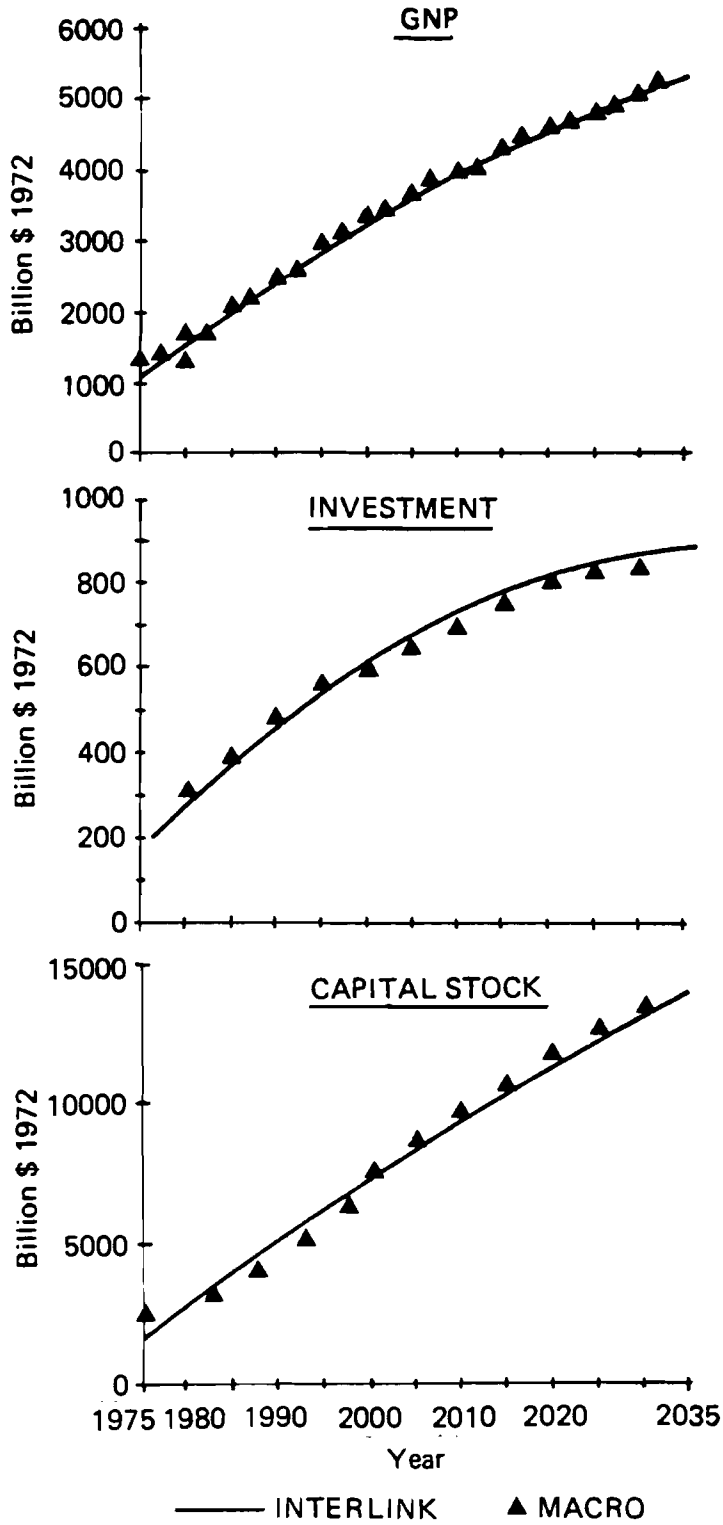

Figure 13. U.S. Base Case: GNP, investment, and capital stock.

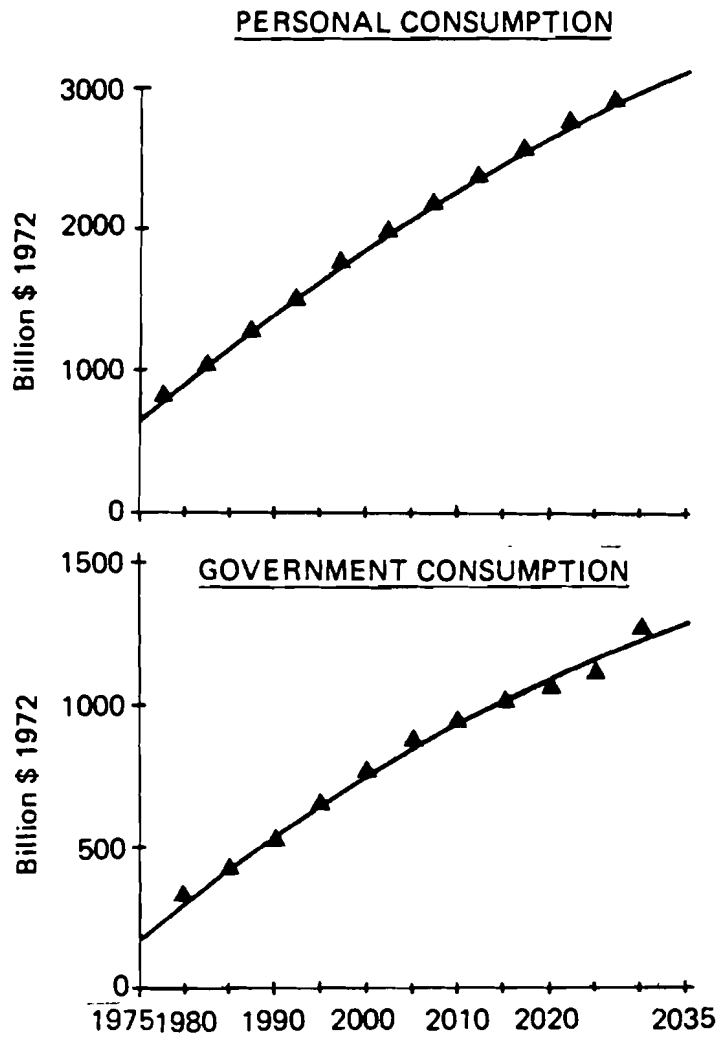

Figure 14. U.S. Base Case: personal and government consumptions.

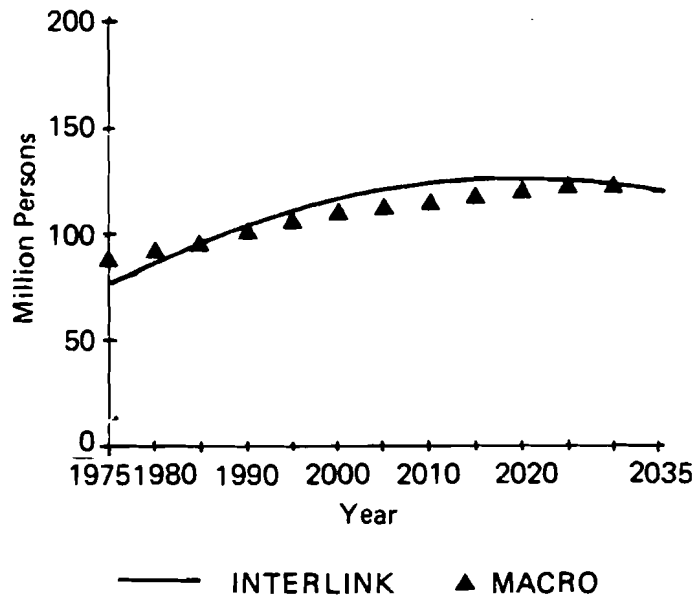

Figure 15. U.S. Base Case: employment.



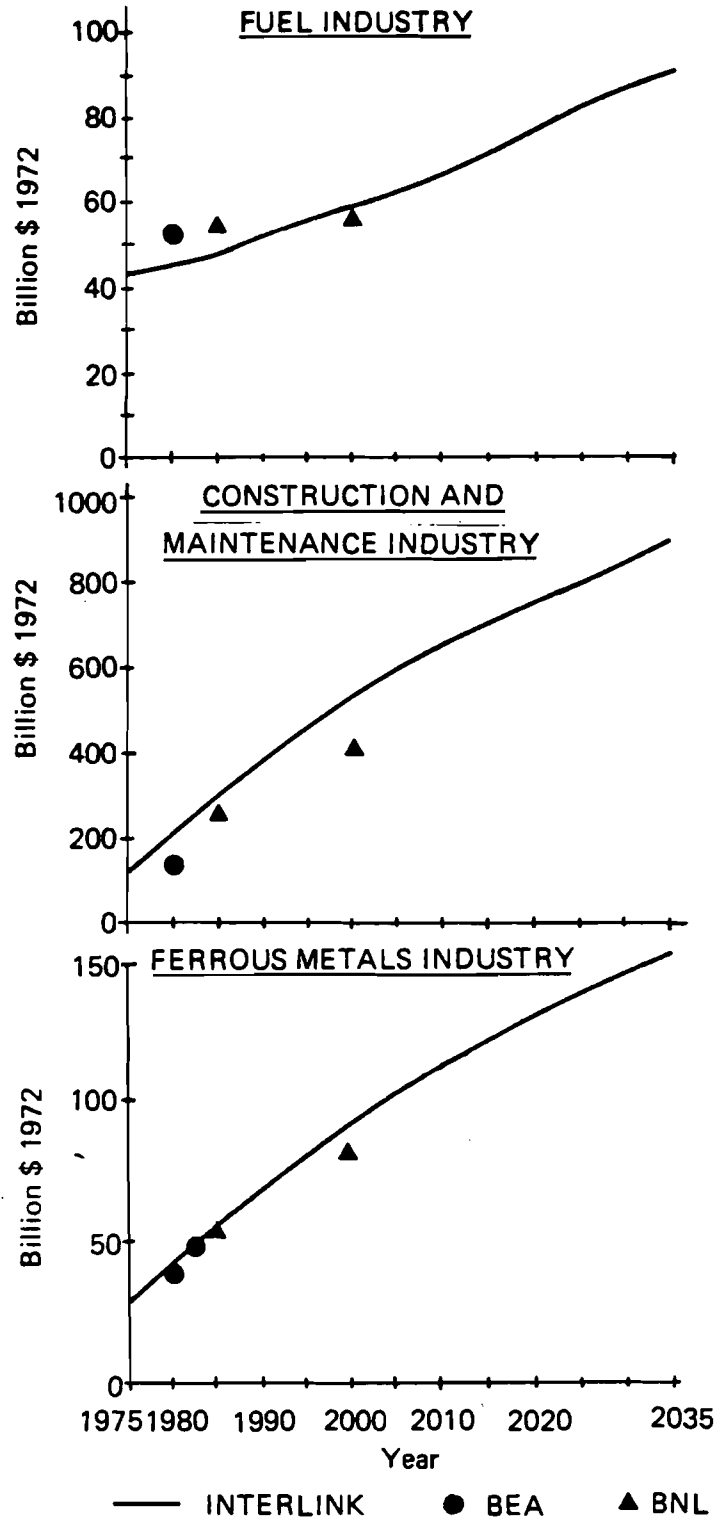

Figure 16. U.S. Base Case: gross outputs of fuel industry; construction and maintenance industry; and of ferrous metals industry (Behling et al. 1957; U.S. Department of Commerce 1975).

REFERENCES

- Agnew, M., L. Schrattenholzer, and A. Voss. 1978. A Model for Energy Supply Systems and Their General Environmental Impact, Appendix to RM-78-26. Laxenburg, Austria: International Institute for Applied Systems Analysis.
- Agnew, M., L. Schrattenholzer, and A. Voss. 1979. A Model for Energy Systems Alternatives and Their General Environmental Impact. WP-79-6. Laxenburg, Austria: International Institute for Applied Systems Analysis.
- Bechtel Corporation. 1975. The Energy Supply Planning Model. San Francisco, Ca., July 1975.
- Behling, D.J., W. Marcuse, M. Swift, and R. Tessmer. 1975. A Two-Level Iterative Model for Estimating Interfuel Substitution Effects. BNL 19863. Brookhaven, Te.: Brookhaven National Laboratory.
- Csaki, C. 1978. First Version of the Hungarian Agricultural Model HAM. RM-78-31. Laxenburg, Austria: International Institute for Applied Systems Analysis.
- Csaki, C. 1979. Second Version of the Hungarian Agricultural Model HAM. WP-79-71. Laxenburg, Austria: International Institute for Applied Systems Analysis.
- Doblin, C. 1977. Capital Formation, Capital Stock and Capital/Output Ratios (Concepts, Definitions, Data, 1850-1975). WP-77-5. Laxenburg, Austria: International Institute for Applied Systems Analysis.

- Grenon, M., and B. Lapillonne. 1976. The WELMM Approach to Energy Strategies and Options. RR-76-19. Laxenburg, Austria: International Institute for Applied Systems Analysis.
- Grenon, M., and I. Zimin. 1977. Resources model. IIASA Workshop on Energy Strategies, Conception and Embedding, May 17-18, 1977. Laxenburg, Austria: International Institute for Applied Systems Analysis.
- Häfele, W., and A. Makarov. 1977. Modelling of medium- and long-range energy strategies, discussion paper. IIASA Workshop on Energy, Strategies, Conception and Embedding, May 17-18, 1977. Laxenburg, Austria: International Institute for Applied Systems Analysis.
- Ivanilov, Yu.P., and A.A. Petrov. 1970. The problem of optimization in dynamic multi-branch industrial models. Colloquium on Methods of Optimization. Lecture Notes in Mathematics Vol. 112. Berlin: Springer Verlag.
- Kononov, Yu.D., and A. Por. 1979. The Economic IMPACT Model. RR-79-8. Laxenburg, Austria: International Institute for Applied Systems Analysis.
- Lapillonne, B. 1978. MEDEE-2: A Model for Long-Term Energy Demand Evaluation. RR-78-17. Laxenburg, Austria: International Institute for Applied Systems Analysis.
- Leontief, W., et al. 1977. The Future of the World Economy, A United Nations Study. New York: Oxford University Press.
- Orchard-Hays, W. 1977. SESAME Mathematical Programming System. DATAMAT REFERENCE MANUAL (Third Edition). Laxenburg, Austria: International Institute for Applied Systems Analysis.
- Orchard-Hays, W. 1980. Formulating, Generating, and Solving Dynamic LP Models. Laxenburg, Austria: International Institute for Applied Systems Analysis (forthcoming).
- Propoi, A. 1976. Problems of Dynamic Linear Programming. RM-76-78. Laxenburg, Austria: International Institute for Applied Systems Analysis.
- Propoi, A., and V. Krivonozhko. 1978. The Simplex-Method for Dynamic Linear Programs. RR-78-14. Laxenburg, Austria: International Institute for Applied Systems Analysis.
- Rogner, H.-H. 1977. A macroeconomic model of the potential GNP (MACRO), discussion paper. IIASA Workshop on Energy Strategies, Conception and Embedding, May 17-18, 1977. Laxenburg, Austria: International Institute for Applied Systems Analysis.

- Tessmer, R.G. 1976. Input-Output Capital Coefficients for Energy Technologies. BNL 50608. Brookhaven, Te.: Brookhaven National Laboratory.
- United Nations Industrial Development Organization. 1977. Constructing the UNIDO World Industry Co-operation Model, a Progress Report. Do. UNIDO/ICIS 24, Vienna.
- U.S. Department of Commerce, Bureau of Economic Analysis. 1974. Survey of Current Business 54(2). Washington, D.C.
- U.S. Department of Commerce, Bureau of Economic Analysis. 1975. Statistical Abstract of the United States, 1975. Washington, D.C.