

CP - 74 - 2

INTERNATIONAL INSTITUTE FOR **IIASA** APPLIED SYSTEMS ANALYSIS  
CONFERENCE PROCEEDINGS

ALPINE AREAS WORKSHOP

H. Franz and C. S. Holling,  
Coordinators

May 13-17, 1974

SCHLOSS LAXENBURG  
2361 Laxenburg  
AUSTRIA



ALPINE AREAS WORKSHOP

May 13-17, 1974

Sponsored by

Austrian Man and Biosphere High Mountain Program (MAB 6)

and the

International Institute for Applied Systems Analysis

Coordinators

Prof. Dipl. Ing. Dr. H. Franz  
Institut fuer Bodenforschung  
Hochschule fuer Bodenkultur  
Gregor Mendelstrasse 35  
A-1180 Wien  
Austria

Dr. C.S. Holling  
International Institute for  
Applied Systems Analysis  
Schloss Laxenburg  
A-2361 Laxenburg  
Austria



TABLE OF CONTENTS

The Obergurgl Model: A Microcosm of Economic Growth in Relation to Limited Ecological Resources .....	1
Appendix A .....	67
Appendix B .....	72

The views expressed are those of the contributors and not necessarily those of the Institute.

The Institute assumes full responsibility for minor editorial changes made in grammar, syntax, or wording, and trusts that these modifications have not abused the sense of the writers' ideas.

The Obergurgl Model  
A Microcosm of Economic Growth  
in Relation to Limited Ecological Resources

by

Bubu Himamowa\*

International Institute for Applied Systems Analysis  
Laxenburg, Austria  
June 1974

INTRODUCTION

The village of Obergurgl, in the head of the Ötztal (Oetz valley) at an altitude of nearly 2000 meters in the Tyrolean Alps of Austria, faces problems similar to those in many areas of the world today. Beginning in about 1950, the village entered a period of economic growth driven by apparently unlimited demand for tourism in the area. This economic growth, expressed largely in terms of hotel construction, is beginning to have serious environmental consequences for the fragile alpine ecosystem, and will soon be limited by availability of land, if nothing else. There is a key simplification in the system: land ownership is tightly controlled by a few families (originally farmers), and the economic development rate is limited by the rate of local human population growth as this rate determines the number

---

\* Pseudonym for the major authors of this report: Fred Bunnell, Pille Bunnell, Sandra Buckingham, Ray Hilborn, Gerhard Margreiter, Walter Moser, and Carl Walters.

of young people willing to invest in new hotels. Since hotels are easiest to build on valley bottom land, this productive land for agricultural grazing is rapidly being lost, and, with it, a major economic option for the villagers. Thus, we see in Obergurgl a microcosm, with some elements missing and others exaggerated, of a major worldwide problem: population and economic growth in relation to diminishing resources. Perhaps by study of such microcosms, we can more clearly identify ways to deal with more major problems.

Obergurgl is now receiving intensive study, mainly on ecological problems, as part of the Austrian Man and the Biosphere Program (MAB 6), and it was felt that IIASA could contribute to this study by providing assistance with systems modelling. This report describes a preliminary dynamic model of Obergurgl which was developed in a five-day workshop sponsored jointly by IIASA and MAB. The workshop (13-17 May 1974) was a truly interdisciplinary attempt to deal with the problem from a systems viewpoint; participants included hotel owners from Obergurgl, a representative of the Tyrolean government, ecologists from MAB projects in Austria and other European countries, a scattering of people from other sciences, and systems modellers from the University of British Columbia, Canada (representing IIASA). Names and addresses of these participants are given in Appendix B.

The focus of this workshop was to develop a preliminary model of human impact on a simple alpine ecosystem and the



policy options, by combining the knowledge and insights of business men, government officials, and scientists. But, in a major sense, the model was not the primary "product" of the effort. In a five-day period it is scarcely possible to develop and validate a rigorous descriptive model--nor to develop a convincing prescriptive analysis. Rather, the prime purpose was to use the focus of the model as a device to identify the potential areas of conflict and the critically missing information, so that rational priorities can be set for further descriptive and prescriptive analyses.

The objectives of our modelling work therefore were threefold: (1) to promote communication among the various interest groups involved in Obergurgl studies, by using the simulation model to provide a common language and focus for attention; (2) to define, through data requirements for the model, critical research areas for the MAB 6 project; and (3) to provide tentative long range (20-40 years) alternate forecasts for the people of Obergurgl concerning likely impacts of various development strategies that they consider practical. We did not really expect before the workshop that objective (3) could be fulfilled, considering the data and conceptual problems which usually arise in such modelling workshops. However, we were lucky and it does appear that the model predictions can be taken seriously; we dwell on these predictions at some length in the final section of this report.

For the casual reader who does not wish to study the entire report, the model predictions can be summarized very simply:

- (1) The most likely natural limiting factor for Obergurgl's economic growth is safe land for building: on this basis, Obergurgl and Untergurgl together may reach a total size of around 90 hotels, with a local population of 600-700 people. This limit could be reached in 15-20 years with continued government subsidy for building, or 20-30 years with no building subsidies.
- (2) Population growth and limitation of building opportunities are likely to combine soon to force a major wave of emigration from the village (perhaps 100 people), with attendant social problems. Government subsidies for continued hotel building would delay this problem for a short time, but would ultimately make it more dramatic.
- (3) Measures for limiting the growth of Obergurgl fall into three classes: controls on building costs (subsidies or taxes), zoning controls on land made available for development or amount of land per hotel, and controls on basic services provided for the village (water,

energy, ski lifts, road access). Among these possibilities, building taxes and zoning controls would appear to be best. Controls on basic services would not slow development in the short run, and would ultimately result in lowered recreational quality of the area through over-investment in the hotels relative to services provided for these hotels.

MODEL COMPONENTS: ASSUMPTIONS, VALIDATION, FUTURE PRIORITIES

In this section, we examine the components of the model which led to the above predictions. Emphasis is placed on basic assumptions and validation, rather than on mathematical details. Problems of missing data and research priorities for the future are discussed in the context of individual model components, then summarized in terms of overall priorities.

Basic components and interactions in the model are summarized in Figure 1. These components were identified by workshop participants as the minimum set needed to make reasonable predictions about the next 30-40 years. The components fall into four major classes: Recreational Demand; Population and Economic Development; Farming and Ecological Change; Land Use and Development Control. Each of these classes of components was made the responsibility of a small sub-group (3-5 people) of workshop participants, along with

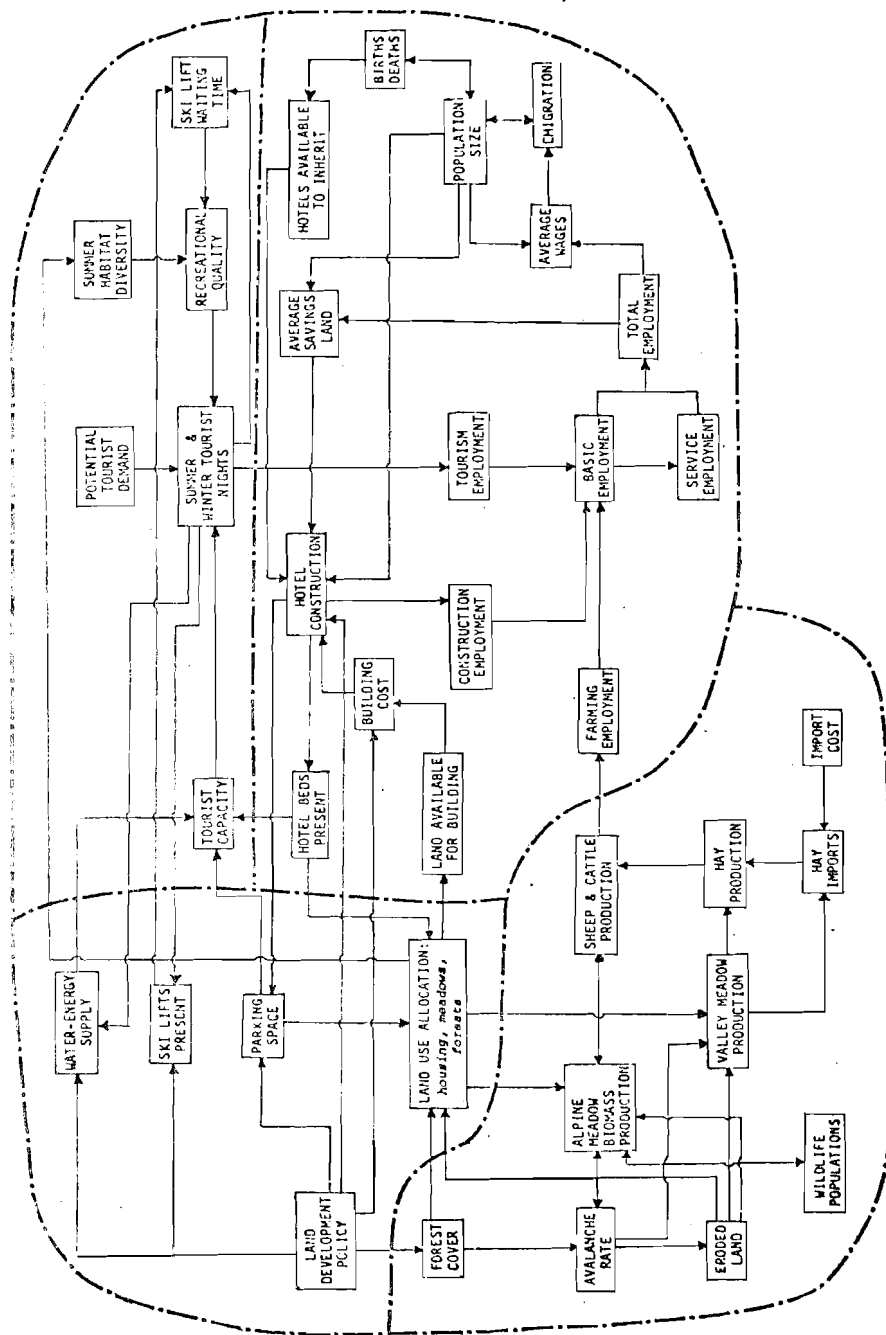

FIGURE 1. MAJOR COMPONENTS OF THE OBERGUGL MODEL. DOTTED LINES SHOW AREAS OF WORKSHOP SUBGROUP RESPONSIBILITY.

one modeller from UBC. The sub-groups, with much interchange of people and ideas, developed sections of the model. These sections were organized into an overall simulation framework by the UBC team. An initial working version of the model was produced by the third day of the workshop, and about thirty 50-year scenarios were produced by the end of the five-day meeting. The state variables and parameters of the model are listed in Appendix A.

#### Recreational Demand Predictions

As shown in Figure 1, it was assumed for the model that recreational demand (measured by tourist nights) is affected by three main factors: (1) a general potential based on population and economic conditions outside the area; (2) the tourist capacity of the village, which would normally be the number of beds available but which could be limited by other services provided for the village (water, energy, parking); and (3) recreational quality of the area, as measured by a habitat diversity index for summer conditions and by ski lift waiting time for winter conditions.

Little is known about potential recreational demand. Winter hotel occupancy rates have been very high since 1950, and the only hint of any demand limit has been a 10-15% drop in occupancy during 1973-74. This drop coincided with the energy crisis over Europe, and a monetary crisis in Germany (Germany and England are the major tourist sources for Obergurgl); according to hotel owners, this drop might have been 10-20% greater except that the Italian Dolomites had

poor snow conditions so visitors were more numerous in the Tyrol. Judging from the general growth in skiing over Europe, there is reason to assume that potential winter demand is essentially infinite. On the other hand, summer occupancy rates have averaged 30% over the past 10 years, though a slight decline has been evident. (The total number of tourist nights has remained essentially constant since 1965, and these nights are distributed over more and more hotels.) Thus, environmental quality changes over the past few years may be having an impact on summer use, though it is possible that mountain areas may become more and more popular for summer tourism as other vacation areas across Europe become more crowded. In balance, it seems safest to assume that (1) summer demand has reached its potential limit considering the existing population of Europe, and (2) further changes in environmental quality would cause summer demands to decrease.

These observations and assumptions formed the basis for our very simple demand submodel. In each simulated year, potential summer and winter demands are calculated as geometrically growing (2% per year) from a 1950 base level. As ski lifts become more crowded, winter demand is reduced according to the functional relationship in Figure 2. As the proportion of meadow land used for housing and the proportion of alpine meadow lost to erosion increase, habitat diversity is assumed to decrease and summer demand is assumed to drop off as shown in Figure 3. Other measures of

A

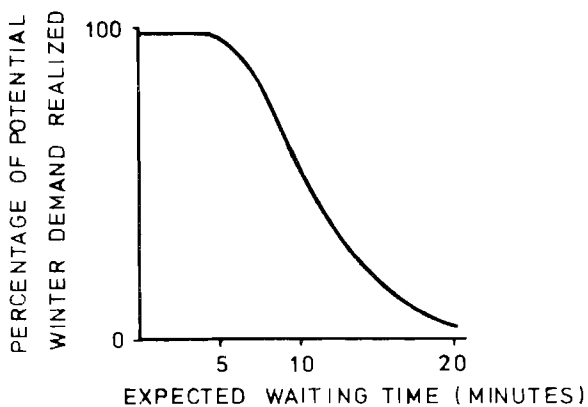

B

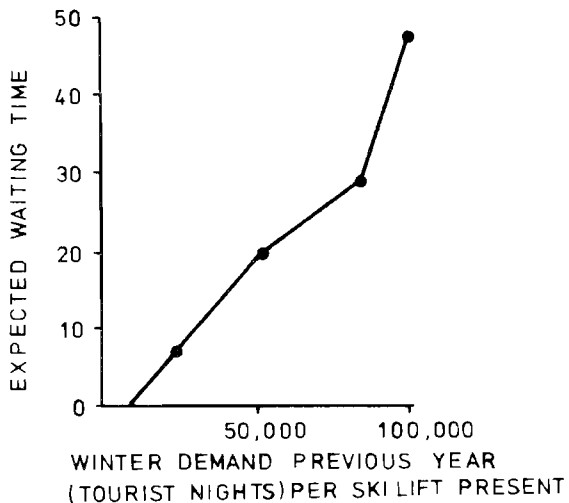

FIGURE 2. WINTER RECREATIONAL DEMAND AS A FUNCTION OF SKILIFT WAITING TIME(A), WHICH IS COMPUTED FROM THE NUMBER OF WINTER TOURISTS AND THE NUMBER OF LIFTS AVAILABLE ( B ).

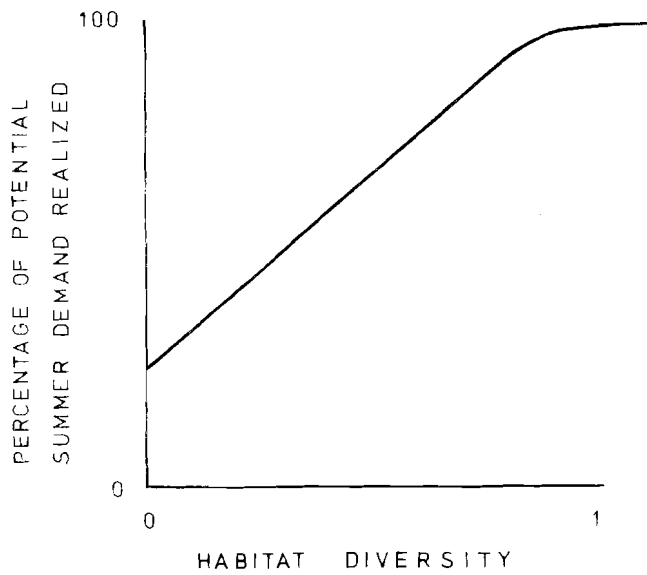

FIGURE 3. SUMMER DEMAND AS A FUNCTION OF HABITAT DIVERSITY, WHICH IS AN INDEX COMPUTED FROM THE AMOUNT OF VALLEY AND ALPINE MEADOW LEFT INTACT FROM BUILDING AND EROSION.



recreational quality, such as ski slope crowding or alpine meadow crowding in summer, were not included in the model.

A simple series of tests in the simulation program are used to determine whether the recreational demand as computed from the potential demand and environmental quality can be accommodated with existing facilities (rooms, water, parking). If not, the demand is reduced according to which facility is limiting, using the following requirements:

<u>Facility</u>	<u>Annual tourist nights per unit facility provided</u>	
	<u>Summer</u>	<u>Winter</u>
Hotel rooms	180/room	270/room
Water delivered to village	16000/litre/sec delivered	
Parking area (hectares)	150,000/ha	224,910/ha

These requirements were calculated from information supplied by the Obergurgl hotel owners. Note that no consideration is given to special requirements or crowding problems that might occur during short periods (peak weekends, etc.) within any tourist season; only overall seasonal totals are used in the model.

Simulated and observed recreational demands for the period 1950-1973 are compared in Figure 4. The demand model is easily capable of mimicking past changes, but this is not a good validation test because the past changes were used to construct the model in the first place. The simulated changes

FIGURE 4

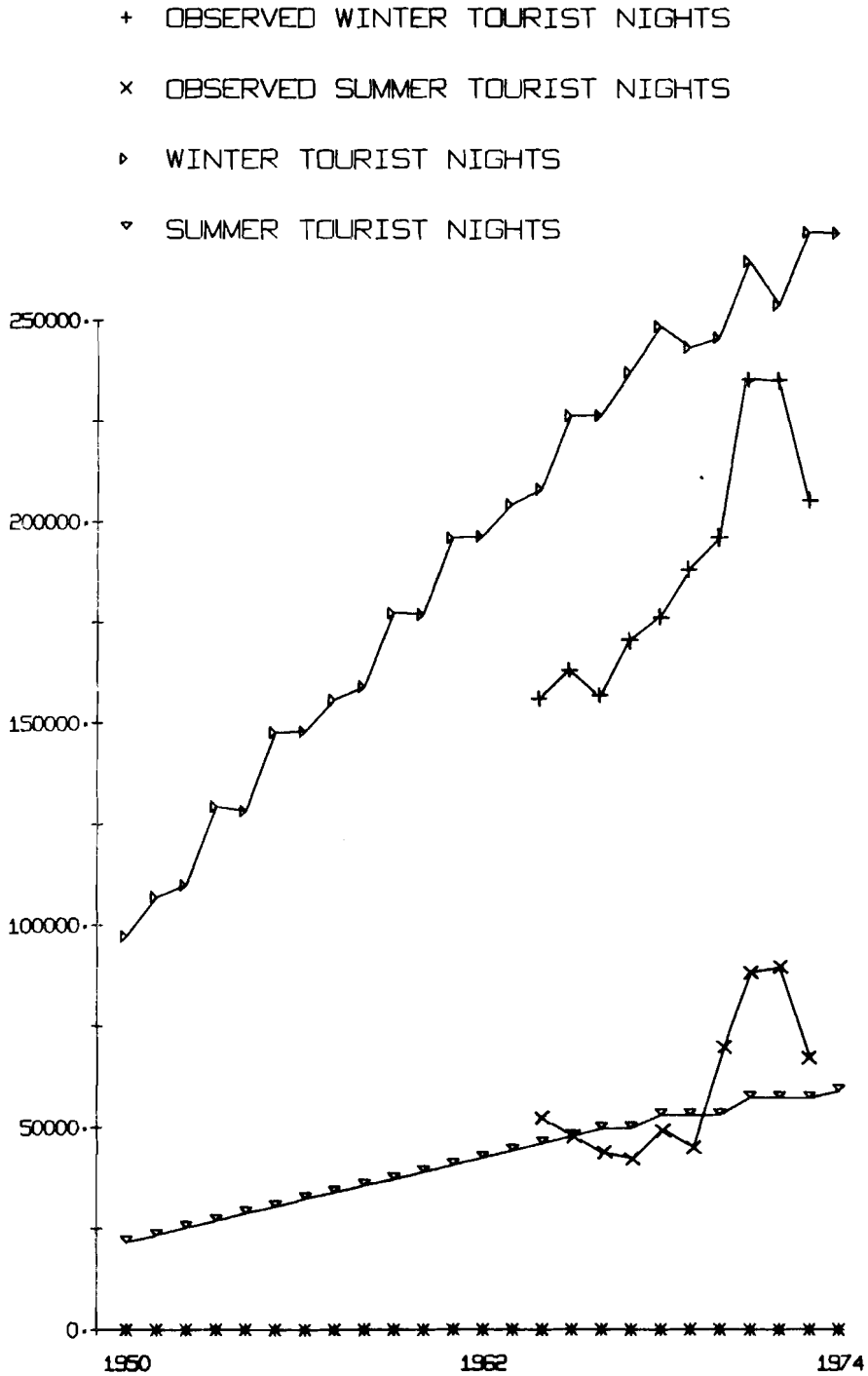

FIGURE 4

+ OBSERVED NUMBER OF SKI LIFTS  
x NUMBER OF SKI LIFT UNITS

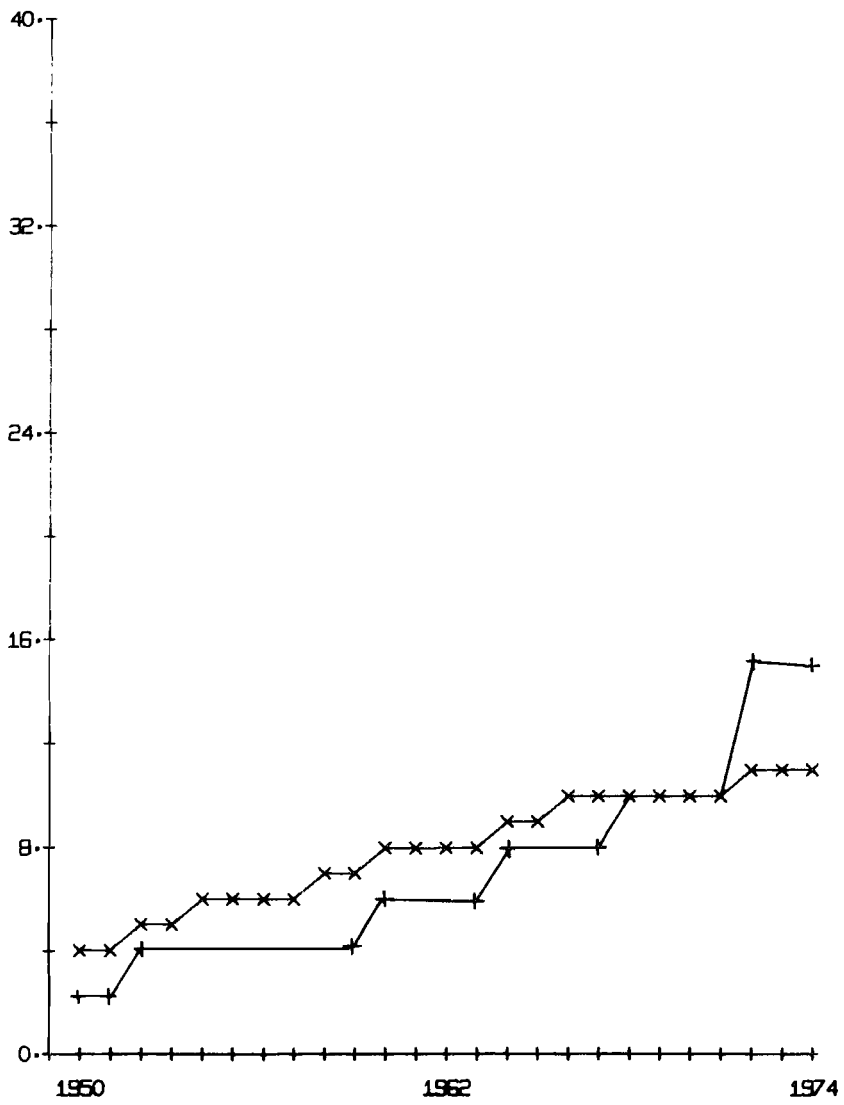
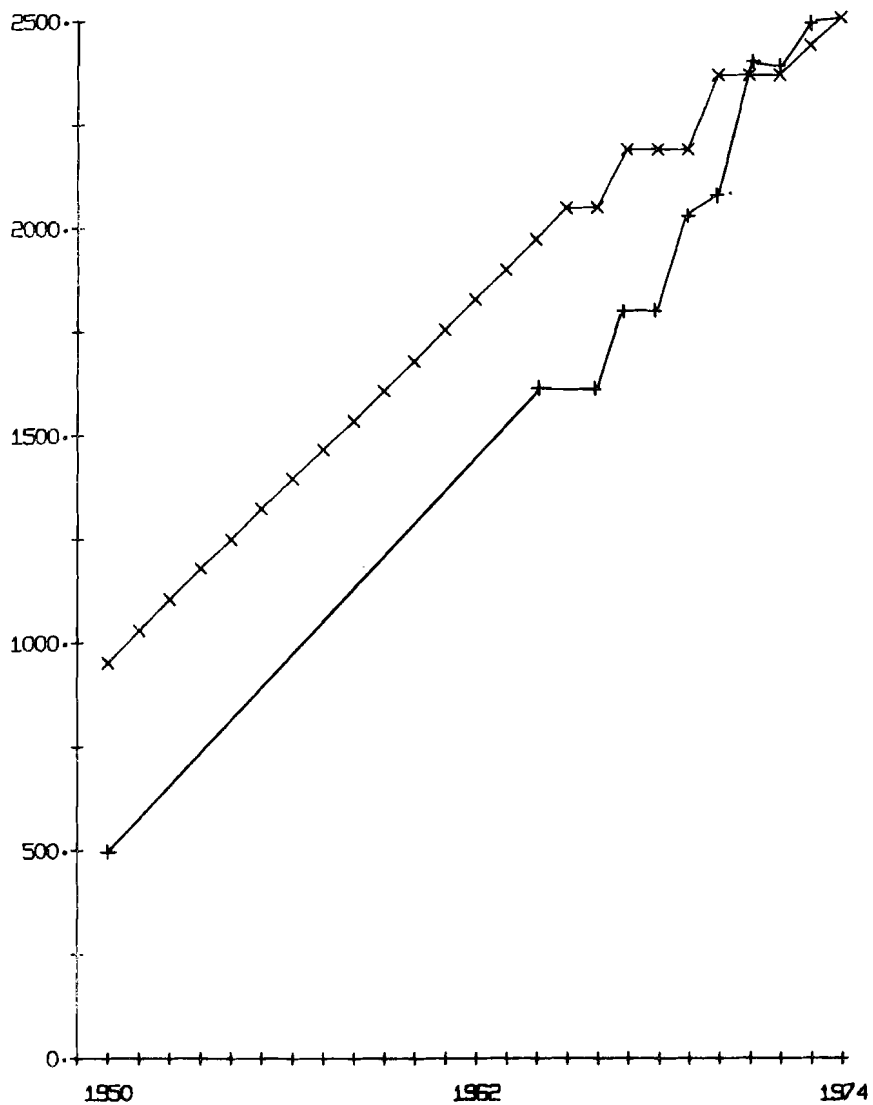

FIGURE 4

+ OBSERVED NUMBER OF BEDS

x NUMBER OF BEDS



in winter demand in Figure 4 are completely due to changes in the simulated number of hotel rooms available, since simulated occupancy rates remained very high (as observed). Occupancy rates remained very high because ski lift waiting time remained low, in turn because the simulated number of lifts was increased (as observed) whenever waiting time exceeded five minutes. Simulated summer demand closely follows observed levels simply because the simulated potential, which was estimated from the observed levels, was always met.

The key weakness in the recreation submodel is in lack of data about likely responses of tourists to changed environmental quality. Also, the model does not represent the spatial distribution of quality relative to recreational use; low quality near the village may be important, even if the overall area is still in good condition. The people best able to acquire such data are the Obergurgl hotel owners themselves. As a first step, we recommend that the hotel owners prepare a series of photographic scenarios of how the village might look after more development, and present these scenarios to their guests. We consider this recommendation to have the highest priority of any developed in the workshop. Such a survey would at least indicate when the kind of people that now visit the area would stop coming. The photographic scenarios could be prepared very easily by dubbing in additional hotels in the places where they are most likely to be built, and by dubbing in various kinds of environmental

changes (eroded areas, etc.) in places where the MAB 6 ecologists think such changes are most likely to occur.

#### Population Growth and Economic Development

As mentioned in the Introduction, the key to economic growth in Oberurgl has been growth in its local population, since land ownership is tightly controlled. Thus, the population and economic components of the model are tightly interrelated, as shown in Figure 1. Population growth is assumed to occur as a function of births, deaths, immigration and emigration; population structure at any time is represented in terms of four age classes (0-15, 15-30, 30-60, 60+) with different contributions to these rates. Economic development is represented in terms of hotel construction and four kinds of employment (tourism, farming, construction, service); it is not necessary to consider other kinds of capital development and building since, in reality, all buildings are used at least in part to house tourists. Construction work is essentially the only growth-based employment in the area.

Population change is simulated simply by adding or deleting proportions of the people in each age class each year. The following annual proportional rates are used for birth, death, and aging:

<u>Age Class</u>	<u>Per Capita Birth Rate</u>	<u>Per Capita Death Rate</u>	<u>Per Capita Movement to Next Age Class</u>	<u>Initial Number (1950)</u>
0-15	0	0	0.067	41
15-30	0	0	0.067	56
30-60	(0.15 for house owners; 0 for non-owners)	0	0.033	40
60+	0	.005	0	9

Immigration rate is assumed to be negligible, since people from outside the village cannot purchase permanent housing, and since few emigrants return to the village. Emigration rates for 15-30 year olds are assumed to depend on employment opportunities in the village, according to the functional relationship shown in Figure 5; this relationship is pure guesswork, since employment has been good and there has been little emigration over the past 20 years. Emigration rates for 30-60 year old people are assumed to depend on land ownership opportunities; people with hotels (either by inheritance or new building) are assumed never to emigrate, while 20% of the people over 30 who have not been able to build (see below) or inherit are assumed to leave each year.

This simple population model is able to mimic changes over the 1950-1974 period quite well, as shown in the following comparison:

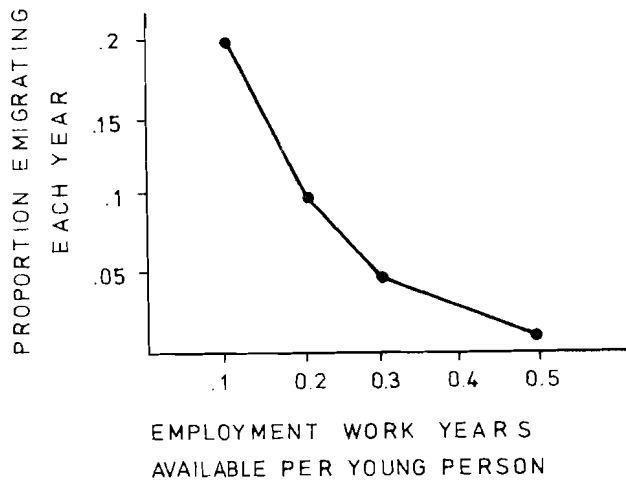

FIGURE 5. ASSUMED RELATIONSHIP BETWEEN EMIGRATION RATE OF YOUNG PEOPLE (15-30 YRS.) AND EMPLOYMENT IN THE VILLAGE.



1974 Age Structure

<u>Age Class</u>	<u>Observed</u>	<u>Simulated from 1950 Base</u>
0-15	107	90
15-30	49	61
30-60	86	76
60+	18	53
Total	260	280

The simulated disparity in number of old people could be easily corrected, as could our underestimate of birth rate. However, predictions about the future depend most heavily on our assumptions above concerning emigration rate changes, and we have no good empirical basis for those assumptions.

In all economic calculations, employment man years are used as a basic currency unit. Employment opportunities in the village each year are simulated with simple, empirical employment multipliers:

<u>Type of Work</u>	<u>Man Years of Employment Generated and Generating Factor</u>
Tourism	0.0016 per winter tourist night 0.0006 per summer tourist night
Farming	0.03 per animal unit maintained
Construction	13.4 per hotel built
Service	0.03 per man year of other employment

The number of animal units maintained by farmers is generated in the ecology submodel (see below), and tourism in the demand submodel (see above). Man years of employment in excess of what village residents can take is assumed to go to seasonal non-resident workers. The supply of non-resident workers is assumed to be unlimited. The model predicted, starting from a 1950 base, that about 900 non-resident workers would be needed every winter by 1974; the actual number in the 1973-74 winter was 800.

Perhaps the most critical variable in the population and economic development submodel is the hotel construction rate. This rate is assumed to depend on the number of resident men over 30 years of age who do not already have a hotel, the amount of savings that these men could have accumulated, and building cost as a function of amount of land still available for development. Profitability of hotels already existing is also considered explicitly as a factor affecting investment, though savings accumulation should automatically take past profitability into account; hotel investment is assumed to stop when occupancy rates drop below 60%. Young men are assumed to be saving money when they are 20 years old, according to the functional relationship in Figure 6. This relationship is modified downward when summer employment opportunities are poor, such that no savings can be accumulated when no summer jobs are available. Since summer employment in the past few years has

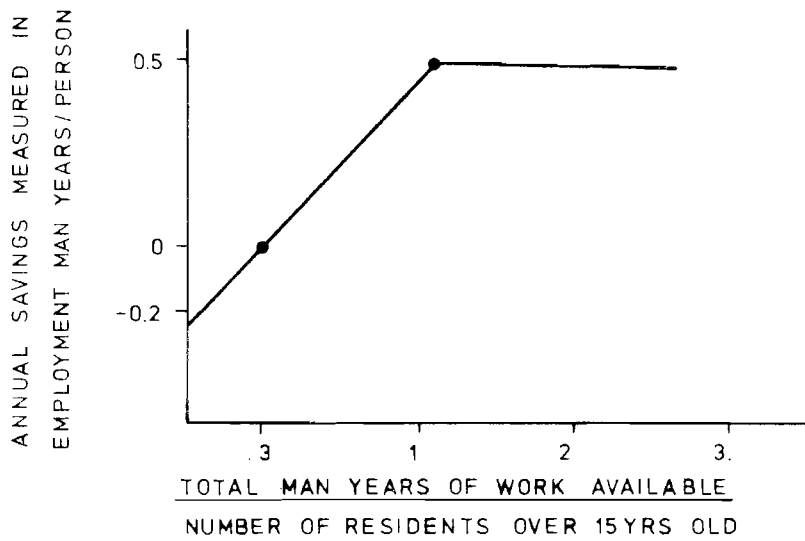

FIGURE 6. RATE OF SAVINGS ACCUMULATION BY PROSPECTIVE HOTEL OWNERS AS A FUNCTION OF EMPLOYMENT IN THE VILLAGE .

come in good part from hotel construction, the young villagers have become dependent on a growth economy: they cannot save enough money to build a hotel without summer employment, and this employment in turn depends on continued growth. We know that in the 1950's a young man could save enough in about five years to build his own hotel, but in recent years construction costs have risen (since poorer building sites must be used), and about seven years of saving are required. We incorporated this problem into the model with the functional relationship shown in Figure 7. To find the amount of land that could be developed each year based on building costs, the average savings level among non-house owners over 30 years of age is fed into Figure 7, and the corresponding land development point is compared to the amount of land already developed. The actual amount of land developed is the potential calculated in this way, provided the potential is not negative and does not exceed the number of young men wanting a hotel divided by the size (hectares) of each hotel plus its lot. Hotels in the past have required an average area of 0.13 hectares, though a policy is contemplated to raise this area to 0.24 hectares. An implicit assumption in all of the calculations about savings and building costs is that all inflationary changes will balance one another: the inflationary effect on building cost is assumed to be cancelled by inflation in wages.

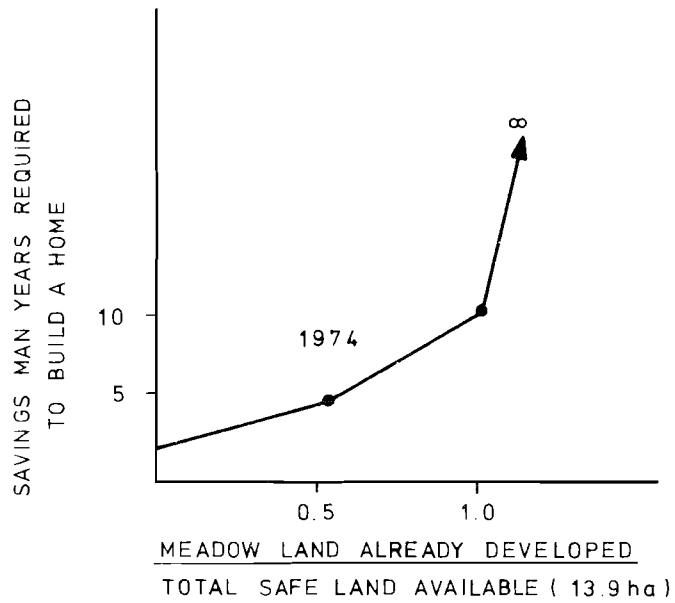

FIGURE 7. ASSUMED RELATIONSHIP BETWEEN RELATIVE HOTEL CONSTRUCTION COST AND AMOUNT OF LAND ALREADY DEVELOPED. RELATIVE COST IS MEASURED IN TERMS OF HOW LONG A YOUNG MAN MUST SAVE MONEY IN ORDER TO AFFORD TO START BUILDING.

Starting from 20 hotels in the 1950 base year, the model predicted, as observed, that about 60 hotels<sup>1</sup> (2500 beds) should be present by 1974 (Figure 4). Thus, it appears that we have captured very well in the model the basic processes that determine land development. The critical relationship for further study is Figure 7: if the building costs rise more rapidly in the future than we have assumed, growth of the village may be limited well before and below the levels that we have predicted. As the development cost relationship is essentially an economic and engineering problem, we recommend that these disciplines be brought into the MAB 6 Obergurgl project.

#### Farming and Environmental Change

In keeping with the general objectives of MAB and the historical contributions of IBP, the basic biological processes in the Obergurgl area have been treated as secondary factors. The intent of this approach was not to deny the importance of the biotic environment, but to concentrate attention of the workshop participants on key economic and policy questions. Despite the secondary treatment of many natural processes, certain key areas of future research were outlined and are presented in the following discussion.

The "environmental" submodel treats three broad groups of phenomena. First, it determines the status of wild and domestic animal populations including the forage necessary

---

<sup>1</sup>Hotels = hotels, pensions (bed & breakfast), and private rooms.

to support these animals. Second, it determines the status of the forest allowing for growth, death, regeneration, and planting. Finally, it considers changes in land-use area sizes due to the process of erosion including several contributing factors.

Since many disparate phenomena are considered in this submodel, the treatment of each is, of necessity, simplistic and somewhat superficial. Furthermore, several of the processes have not been critically evaluated by field experimentation or documentation and the pertinent data bases are sparse. Many interactions and parameter values required estimation. There was not always agreement among the workshop participants as to what the estimated values should be, and hence the model was constructed to allow the option of using different hypotheses or estimates during simulation.

#### Animal Population Patterns

Three species of domestic animals and one wild species are considered in the model. The chamois is the only wild-life species considered. They are considered potentially important to model predictions because of their aesthetic value to tourists, their recreational value to hunters, and their possible role in damaging forest regeneration. Chamois grazing activity is presently considered to occur outside the land-use areas considered by the model. Population dynamics are simulated simply by postulating birth, death, and hunter

kill rates. Model runs specified no damage, constant hunting pressure, and little value to the tourist; so these animals did not form an important component of the system. If there is any indication that the presence of the species is important, data on their population dynamics and feeding behaviour will be required.

Cows, on the other hand, are directly important to the tourist industry of Obergurgl in at least two ways: provision of fresh dairy products and contribution to the picturesque nature of the landscape. The models sets initial stocking rates for cows as well as for horses, sheep, and the number of sheep brought in from other portions of the Tyrol for summer grazing. Stocking rates for the Obergurgl animals are reduced if insufficient forage is available. Horses are considered a luxury and, when forage is limiting, are reduced first, then sheep and finally cows.

Forage available for the Obergurgl domestic stock is calculated in three steps. First, the production from the valley meadows and alpine hay meadows is computed. Forage requirements of the livestock are then determined. Finally, the amount of hay that must be imported to meet these requirements is determined and when economically possible this hay is imported.

Production estimates are computed simply: an average production per hectare ( $GROWB = 3700 \text{ kg/ha/yr}$  for valley bottom meadows and  $GROWA = 1750 \text{ kg/ha/yr}$  for alpine hay



meadows) is multiplied by the number of hectares of the appropriate meadow that are available. There is presently no provision for reduced production through tourist impact or overgrazing. Initially, there are 96 ha of valley bottom meadow producing 355,000 kg annually and 90 ha of alpine hay meadows producing 157,500 kg annually.

The model assumes that summer grazing of cows presently occurs in areas that are not explicitly considered by the model (modified dwarf shrub zone). Thus, summer grazing requirements of cows are ignored. Sheep grazing effects are similarly considered inconsequential and are invoked only during the computation of one of the two formulations of their contribution to erosion. One formulation of the erosion process assumes that sheep contribute in a manner directly proportional to their grazing intensity and density. The grazing intensity is represented by variable SEROD ( $0 \leq \text{SEROD} \leq 1$ ) which approximates 1 as grazing requirements relative to the amount available become large, and tends to 0 as requirements become small relative to amounts of forage available. The grazing requirements of sheep are computed by summing the daily food demand per sheep for both resident and non-resident (e.g. Süd-Tyrol) sheep over the number of days that each group is present in the alpine areas of Obergurgl.

Winter forage requirements for domestic livestock are typically met by local haying and import of other hay. The

model computes total forage requirement by summing the needs of all livestock. Cattle and horses are assumed to require CEAT kg of forage/animal over the winter period (CEAT = 3600 kg). Sheep are assumed to require SEAT kg/sheep/year. Presently, SEAT = 730 kg and is modified by the proportion of a year that the sheep are kept inside.

Once the hay requirements have been computed these are compared with hay production to determine whether hay must be imported. If the wage index is greater than a specified parameter (WHAX(2) = 1.0), all the required additional hay is imported; and if it is less than WHAX(1)·(.2), no hay is imported. Furthermore, to account for inflation, the requisite wage index (WHAX(2)) for import of all required hay has a growth rate of WHAGRO. As already discussed, stock is reduced if insufficient fodder is available. Considerations of differential food quality requirements--such as cows requiring better fodder than sheep--are not encoded in the present model.

### Forests

Forests are considered to modify the rates of avalanche and erosion. Thus, their growth and extent are simulated in the "environmental" submodel. The linkage of forest protection to tourism was left weaker than may be the case in reality; at present the model only considers a small effect on the amount of land eroded.

Area (6) is forested and Area (5) forestable land. With the "environmental" submodel, the area of forestable land is further subdivided.

FORTRAN

<u>Variable Name</u>	<u>Meaning</u>
STEEP	land without trees
FOR 1	land with trees 1-2 yrs past planting
FOR 2	land with trees 3-50 yrs past planting

The general pattern of changes applied to these land classes can be depicted very simply.

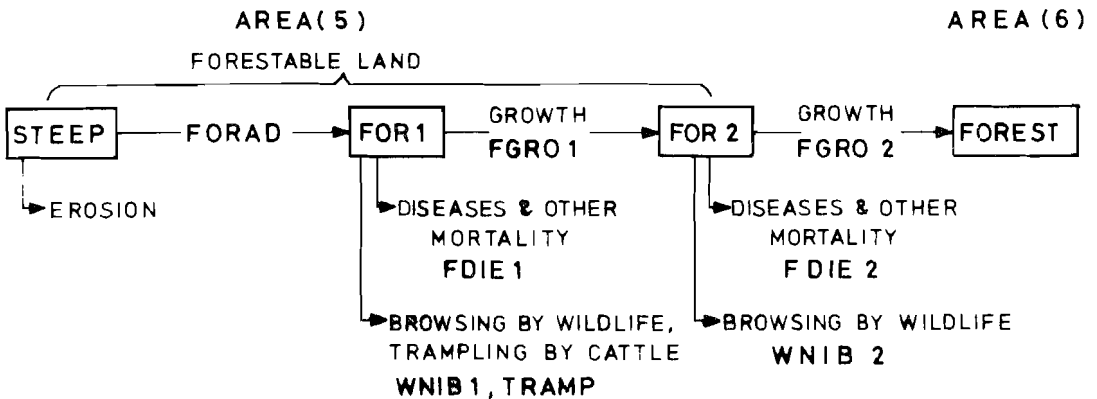

FORAD is a policy variable which sets the number of hectares of forestable land which will be planted in a given year. For the first two years after planting, trees (Pinus cembra) are subject to a rather high mortality rate (FDIE 1) due to diseases and soil factors. In addition, these young trees have a specified probability of being browsed by chamois (WNIB 2) or trampled by cows (TRAMP). Workshop discussions of the fate of recently planted trees were controversial and workshop model runs allowed no browsing by chamois (WNIB 1 and WNIB 2 = 0). Since establishment of protection forests would not only reduce erosion, but would modify the protected area available for hotel building, the modelling exercise indicated that forest regeneration processes are potentially a matter of critical biological and economic concern and should therefore be the subject of further study.

As the recently planted trees grow into the second arbitrary age class (as a function of FGRO 1), they are subject to similar kinds of mortality, but at different rates than trees in the first age class. Estimation of relevant parameters for the second age class proved equally difficult. The second age class becomes forest as a function of the growth rate FGRO 2 and mortality rates WNIB 2 and FDIE 2.

Changes in the amounts of forestable land are thus a result of growth into forest over a period of many years,

or losses due to erosion. Over the time span of the model the pine forests do not age sufficiently to decrease in extent, but may be increased through reforestation practices.

### Erosion

In some respects the transfers of land from one land-use category to another due to the processes of erosion may be the most important section of the environmental submodel since the extent of land in each of the land-use categories influences many major processes. Erosion causes transfer of land from forestable land, alpine meadow, and alpine hay meadow (Areas (5), (7), and (9), respectively) to eroded land (Area (8)). Processes contributing to erosion are treated differently over the area affected as well as by causal factors.

Alpine meadow suffers erosion due to sheep and tourists. Sheep erosion (SEROD) is calculated as proportional to overgrazing, as already discussed, or alternatively as a standard rate per sheep present (SEMAX = .0003 ha/sheep/yr). Tourists erode according to the number of winter tourist days times a winter erosion rate (ERWU = .000,0002 ha/tourist/day), plus the number of summer tourist days times a summer erosion rate (ERSU = .000,0002 ha/tourist/day) plus an additional amount for the construction of each new ski lift unit (ERSK = 2 ha/lift unit).

Forestable land is eroded according to an intrinsic rate subject to forest protection and the activity of cows. The

model assumes that forestable lands are subject to an intrinsic rate of erosion (FRAT = .1 ha/yr) which can be decreased as more of the land becomes forested, according to the ratio

$$\text{ERVIV} = \frac{\text{forestable land}}{\text{forestable land} + \text{forested land}} \cdot$$

The same forest protection ratio (ERVIV) is used to reduce a maximum erosion rate per cow (CMAX = .005 ha/yr) present in the model.

Finally, the alpine hay meadows may also be eroded according to an intrinsic rate (HRAT = .01 ha/yr) modifiable by the forest protection ratio index (ERVIV).

All erosion processes are additive. The appropriate number of hectares is subtracted from the forestable, alpine, and alpine hay meadow areas, and added to the eroded land. Erosion recovery may be simulated as a natural rate or as a policy option by setting a parameter RECOV to correspond to a certain number of hectares per year which is transferred back from eroded to alpine meadow. All the erosion rate parameters were guesses as no real data were available. There was again some controversy as to the magnitude of the postulated effects (even as far as their existence). The parameter values mentioned above produced about 2 ha of eroded land not associated with ski lift construction over the 25-year period, 1950-75, when other model dynamics were realistic.

### Model Dynamics

Initial model runs demonstrated that the environmental submodel was rather weakly linked to the socio-economic sections. Trees and chamois grew at an intrinsic rate influenced only by set policies on hunting and reforestation. Stock generated a slightly changing demand for import hay, which as wages decreased, could not be met, so stock was reduced as formulated: horses, then sheep, and finally a very few cows.

Erosion occurred at a rather constant rate but did not seem to have a major effect other than reducing the amount of forage available.

Just before the end of the workshop, the model was amended to produce a scenario where the summer tourists would be very sensitive to the aesthetic quality of the landscape as measured by the percent of alpine meadow eroded. As erosion increased and summer tourism decreased, emigration was initiated somewhat earlier, hotel building stabilized, winter tourism was stabilized, and the lower population in the area maintained a relatively steady wage level. Erosion rate also decreased as a feedback of less tourist activity. A natural stability was indicated. The critical question is to what extent tourists are sensitive to landscape aesthetics; and, if this sensitivity and resultant stabilization is to be expected, what quality of

landscape will finally trigger the process. Stabilization due to an unaesthetic environment may not be in the best interests of the villagers.

A further interesting indication produced by the model was the incredible time lag to be expected in a reforestation program. When reforestation was very high for the first 15 years ( $\leq 15$  ha/yr) no noticeable effect occurred in the model until about the 30th year of simulation. At that point erosion rates had significantly decreased as there was a noticeable accumulation of young forest. In part, the lag is due to the slow growth rates of the forest. In part, it is due to the effects of forest on stabilizing adjacent hay meadow areas.

#### Implications

In summary, despite the rather simplistic nature of the environmental submodel, some key areas for further investigation were identified. These can be enumerated briefly in point form (the order does not imply relative importance):

- (1) Forest regeneration processes and broad causes of failure; e.g., relative losses due to diseases, snow creep, trampling, etc.
- (2) Nature of environmental perception; e.g., how do tourists perceive and respond to changes in the environment?
- (3) Processes that induce erosion and ameliorate or hasten recovery from erosion; e.g., what processes



are critical in causing erosion and how can recovery be hastened by fertilization, seeding, etc.?

- (4) Grazing processes of wild and domestic stock; e.g., what is the spatial distribution and pattern of the grazing process?
- (5) Successional patterns of present meadow areas; e.g., how are these influenced by grazing and erosion?

The five general areas mentioned were all demonstrated to be important to the predictions requested of the model. That is, their importance is not simply one of physical or biological interest, but significant to the economic planning in the area. For example, it is impossible to guide hotel owners questions concerning the use of domestic grazing stock to maintain "attractive" alpine meadows with the present model. The model framework is appropriate, but certain processes are not incorporated. Similarly, the model presently suggests that protected areas suitable for hotel construction cannot be increased by forest planting practices alone, but would require some form of "Lawinenverbau." While the suggestion is probably correct, more information on forest regeneration is necessary before potential economic advantages and disadvantages of such a practice could be rigorously evaluated.

Land Use and Development Control

One sub-group of workshop participants was given the responsibility of identifying alternative schemes for controlling the growth of Obergurgl, and for ensuring that the sub-models described above could accept such schemes. A necessary first step for this sub-group was to recognize that controllable variables are not necessarily the same as variables which measure the results of control; for example, hotel size may be controlled by zoning and may result in better environmental quality, whereas the environmental quality cannot be controlled directly. Thus, it was necessary to identify indicators for the results of control as well as the controllable factors.

Our work led to the following table of possible control actions by the various institutions that have some influence on Obergurgl:

<u>Control Action</u>	<u>Institutional Responsibility</u>
(1) Regulation of room prices to control occupancy rates	Hotel owners
(2) Total area zoned for building	Village, regional government
(3) Hotel size (per building plus surrounding lot)	Village government

<u>Control Action</u>	<u>Institutional Responsibility</u>
(4) Hotels built per year	Village government
(5) Hotel building subsidy or tax	Regional government
(6) Reforestation and agri- cultural maintenance subsidy	Regional government
(7) Provision of basic ser- vices to village (wa- ter, energy)	Village (water) or regional government (energy)
(8) Provision of recrea- tional facilities (ski lifts, trails)	Village (hotel owner consor- tium)

These control actions fall into three basic classes: land zoning, building rate modification, and provision of tourist services besides buildings. Obviously, many control actions are possible besides the ones listed above; for example, the formation of special nature protection areas; such controls were not considered because the model would not be sensitive to them, in turn because we represented perception of environmental quality patterns too simplistically.

Land zoning and building rate controls are implemented in the model very simply by changing the axes of Figure 7. Zoning controls change the total land available, while subsidies and taxes lower or raise the building cost curve.

Since the rate of land development never achieved very high values even in the absence of any controls, no scenarios were developed with explicit control on building rate.

In the absence of special input, the model adds basic services and recreational facilities according to demand alone. For example, the model "builds" a new ski lift whenever lift waiting time exceeds 5 minutes. To simulate control of services, we simply programmed an upper limit for development of each service, and set this upper limit at very high values, except in scenarios designed to test the limit.

To provide an independent assessment of the likely impacts of various development policies, the workshop participants were asked to fill out a "pre-simulation expectations table" (Table 1). In this table they indicated what they thought would be the qualitative effects (plus or minus) of a series of alternative controls on each of a series of "impact indicators." The impact indicators are simulation variables that measure quality of life in various ways. As Table 1 shows, there was little consensus among participants about most effects of most policies. This is somewhat surprising in relation to the environmental impact indicators, since most of the participants were ecologists with presumably the same general outlook. None of the pre-simulation expectations bear any clear relationship to the final predictions made by the model.

TABLE 1. PRE-SIMULATION EXPECTATIONS TABLE. For each position in this table, participants indicated whether the Control Action (row) would improve the condition in the column, or make the condition worse relative to what would occur with no control. Numbers in each box indicate how many participants had each opinion.

Control Action Responsible	POPULATION IMPACTS					ENVIRONMENTAL IMPACTS					
	Final number of hotels	Occupancy rate	Final Population	Social dis-satisfaction (emigration rate)	Wage level (employment)	Farming potential	Environmental Quality (diversity)	Ski Area Crowding	Final Meadow Area	IMPACT VARIABLE	
										Control	Control
Room prices (hotel owners)	+2 -5 0(3)	+0 -8 0(1)	+4 -4 0(2)	+3 -3 0(4)	+7 -2 0(1)	+5 -2 0(3)	+10 -0 0(0)	+1 -1 0(8)	+3 -2 0(5)		
Total Area for buildings (Region-town)	+3 -7 0(0)	+6 -3 0(1)	+2 -8 0(0)	+10 -0 0(0)	+1 -4 0(5)	+5 -3 0(2)	+7 -3 0(0)	+3 -3 0(0)	+7 -3 0(0)		
Beds/Hotel (town)	+0 -7 0(3)	+1 -6 0(3)	+4 -3 0(3)	+2 -5 0(3)	+8 -1 0(0)	+3 -3 0(4)	+0 -9 0(1)	+8 -0 0(2)	+1 -3 0(6)		
Area/Hotel (town-region)	+1 -7 0(2)	+7 -2 0(1)	+3 -5 0(2)	+6 -2 0(2)	+6 -4 0(0)	+1 -6 0(2)	+8 -2 0(0)	+2 -6 0(2)	+2 -7 0(1)		
Area for hotels each year (town)	+0 -9 0(1)	+7 -2 0(1)	+1 -7 0(2)	+8 -1 0(1)	+0 -4 0(6)	+2 -0 0(6)	+7 -3 0(0)	+0 -9 0(1)	+5 -3 0(1)		
Building cost tax (region)	+1 -8 0(1)	+3 -4 0(2)	+1 -6 0(3)	+9 -0 0(1)	+2 -4 0(3)	+6 -2 0(2)	+9 -0 0(1)	+1 -7 0(2)	+7 -7 0(2)		
Reforestation (region)	+4 -2 0(4)	+7 -0 0(3)	+5 -2 0(3)	+2 -2 0(6)	+6 -2 0(2)	+4 -5 0(1)	+9 -1 0(0)	+5 -2 0(3)	+1 -7 0(2)		
Water and energy supply fixed (region)	+2 -6 0(1)	+4 -3 0(2)	+3 -6 0(1)	+6 -4 0(0)	+3 -4 0(3)	+2 -7 0(1)	+7 -3 0(0)	+2 -6 0(2)	+3 -2 0(4)		

#### GENERAL PREDICTIONS

Though the model was developed to represent a rich variety of interactions and feedback mechanisms, its final predictions depend largely on a few key relationships. As shown in the "no control" scenario of Figure 8, these relationships can be summarized very simply:

- (1) In the face of essentially infinite potential demand, growth of the recreation industry has been limited by the rate of local population growth.
- (2) The amount of safe land for development is disappearing rapidly, while the local demand for building sites is continuing to grow.
- (3) As land is developed, prime agricultural land is lost and environmental quality decreases.
- (4) Recreational demand may begin to decrease if environmental quality deteriorates further.

Thus, the village may soon be caught in a painful trap, as its growing population and economy collide with declining resources and demand. This collision may be felt by the older, established hotel owners as well as the younger people, if more hotels are forced to share a declining number of tourists.

Figure 9 shows an alternative future, again generated without development control, but under the assumption that recreational demand will remain at 1973-74 levels (e.g., continued energy and monetary crises over Europe). A key

aspect of this prediction is that stabilization of demand will not immediately stop the growth of Obergurgl; there is no reason to suppose that investment in hotels will suddenly stop, since the recreational business is still profitable. Instead, over-investment in hotels is likely to occur, until no owners are doing very well. On the positive side, a continued demand crisis should help to spread the inevitable emigration pulse over a longer period of time, so that widespread social dissatisfaction would not develop all at once.

The results of a government subsidy to help young people build hotels are presented in Figure 10, under the assumption of unlimited potential demand. A striking feature of this scenario is the large emigration of young people that should occur when the safe building land is exhausted. The subsidy should not have a great effect on rate of economic growth, but should make conditions much worse when growth does stop. If the government does pursue a subsidization policy, a major planning focus for the village should be to immediately begin educating young people about the problems that they will soon face, with a view to helping these young people find alternative ways of life to that which they see among their parents.

At another extreme, Figure 11 shows a scenario involving government taxes to make new building more difficult. This policy would slow economic development and spread out

the emigration pulse. Though attractive at first glance, this scenario is probably not politically feasible: no government would last very long that set a discriminatory tax on its largest body of voters, the young people.

In an effort to find more subtle controls, we looked at several scenarios (Figure 12, Figure 13 involving limitation of services (ski lifts, water) provided for tourists). All of these scenarios have in common that they limit recreational demand rather than village growth, just as in the demand crisis scenario of Figure 9. The same problems of overcapitalization in hotels and extended emigration arise in all cases. In addition, the quality of the recreational experience for most tourists would decline, so everyone would lose in the long run. Thus, we strongly recommend against any control policies that involve limitation of tourist services other than hotels.

A scenario involving land zoning to make each new hotel use a larger lot (buildings not larger, but more spread out) is shown in Figure 14. The effect of this policy would be to slow hotel building (since young people would be forced sooner to use more expensive sites) and decrease the eventual maximum size of the village. However, the emigration problem would not be solved, in effect no meadow land would be saved, and the village might still look too large to many tourists. Before any development control of this kind is initiated, tourists should be presented as recommended above



with alternative pictures of how the village would look with future hotels spread out as opposed to clustered together. Spreading hotels out might well do more harm than good.

We could continue on and on in discussion of alternative scenarios for controlling growth, but the short discussions above appear to cover the main feasible options. From the variety of scenarios that were tried, some most likely and some most extreme predictions can be drawn:

- (1) Even if meadow land for building were not limited, the village would probably not grow to more than 150 hotels (double its present size) by the year 2000, based on the number of young people who are likely to reach the house building age. The most likely prediction is 80-90 hotels present when the village reaches its safe land limits in about 20 years.
- (2) Hotel building will not significantly alter the amount of valley grazing meadow in the near future; only about 20% more of this land is ever likely to be developed.
- (3) With no land limits, the local population could reach 700 persons by the year 2000, with a tourist use of about 600,000 nights/year. The most likely estimate for population is that equilibrium will be reached near the turn of the century, at 500-600 persons with a tourist use of about 350,000 nights/

year. The most likely population growth rate for the next decade or two is 2.6% per year, considering the increases that are likely in emigration rates.

The ecological implications of these predictions were not made clear by the modelling work, since the ecological data base is still very poor. Present recreational use may already be more than the sensitive alpine meadows can tolerate; doubling of recreational use is not unlikely and may be disastrous.

#### RECOMMENDATIONS FOR RESEARCH ON OBERGURGL

A variety of recommendations for further research are scattered through this report; towards the end of the workshop, participants were asked to rank these recommendations to give a clearer picture for the MAB 6 planners. After considerable discussion, consensus was reached on the following priorities:

<u>Rank</u>	<u>Project Recommended</u>
(1)	Sociology of villagers in relation to attitudes about land ownership, emigration, and economic opportunities.
(2)	Perception of environmental quality by villagers and by tourists, initially by means of photographic scenarios of future possibilities.
(3)	Basic mapping of ecological conditions in the area, especially in relation to ski development and soil erosion.

<u>Rank</u>	<u>Project Recommended</u>
(4)	Determination of primary production of pastures and alpine meadows in relation to grazing by wild and domestic animals.
(5)	Projection of potential recreational demands in relation to changing transportation systems and public attitudes across Europe.
(6)	Continued "policy analysis" of alternative development schemes and research priorities, as done in this report.
(7)	Experimental ecological studies involving manipulation of grazing patterns, trampling of meadows by people, and construction activities.
(8)	Economic analysis of the village in terms of employment structure, savings patterns, and cost problems in hotel construction.

In retrospect, it appears that the model described in this report can, after some relatively minor refinement, provide a solid basis for predictions about the human aspects of environmental change in Obergurgl. It remains for future modelling work to develop the ecological side of the story more fully, so a truly balanced picture of the overall system can eventually emerge.

FIGURE 8

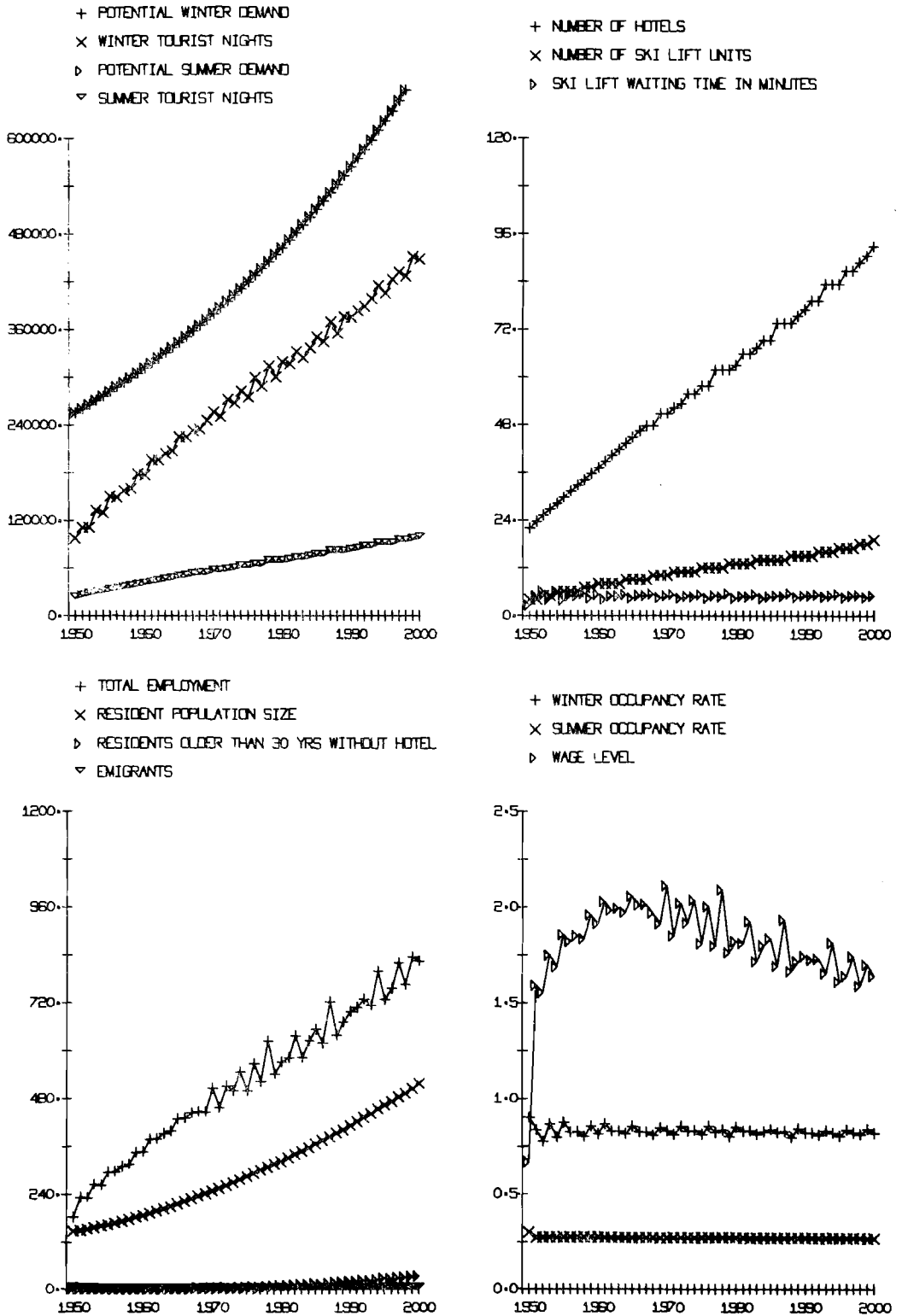

FIGURE B

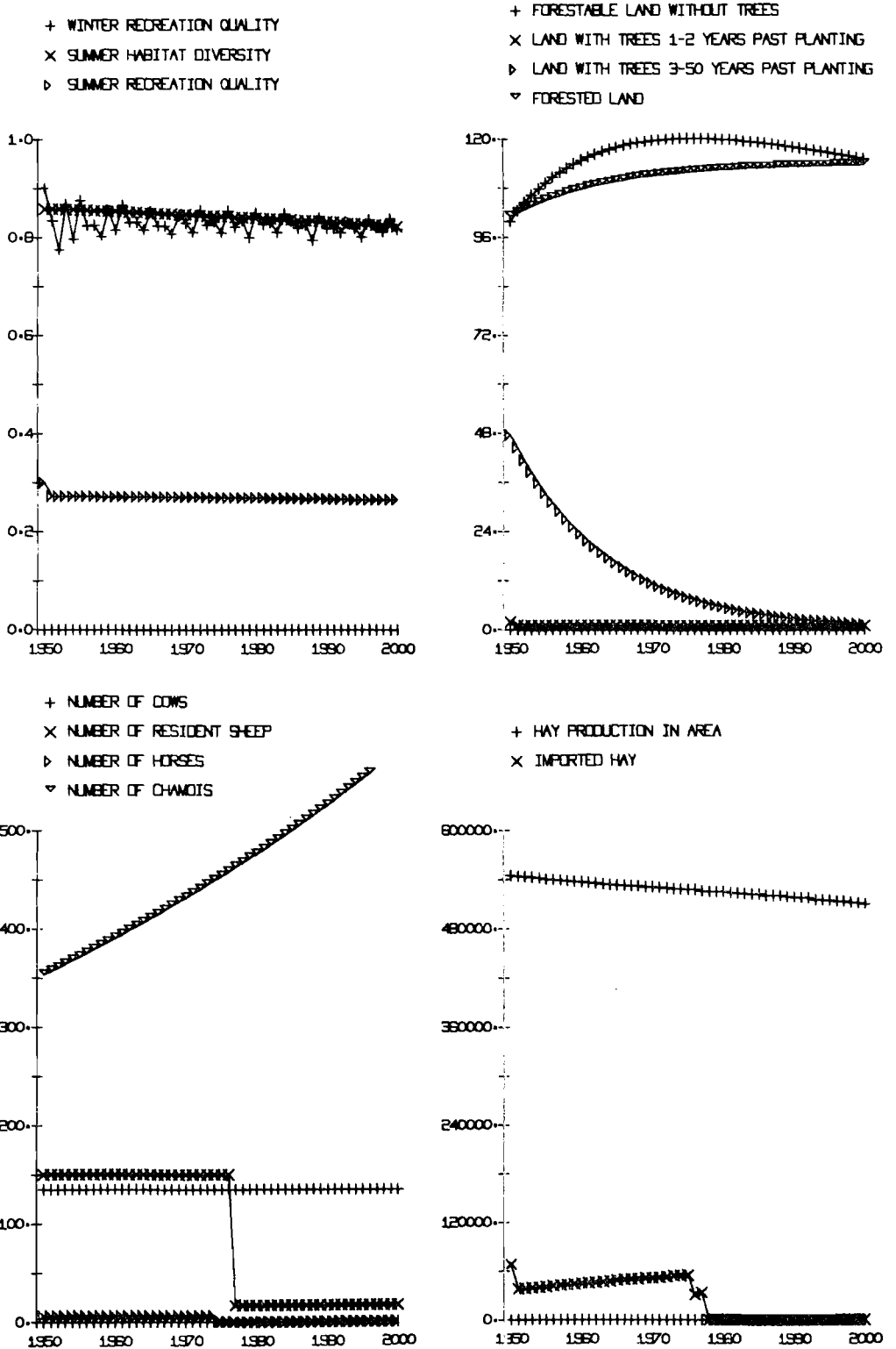

FIGURE 8

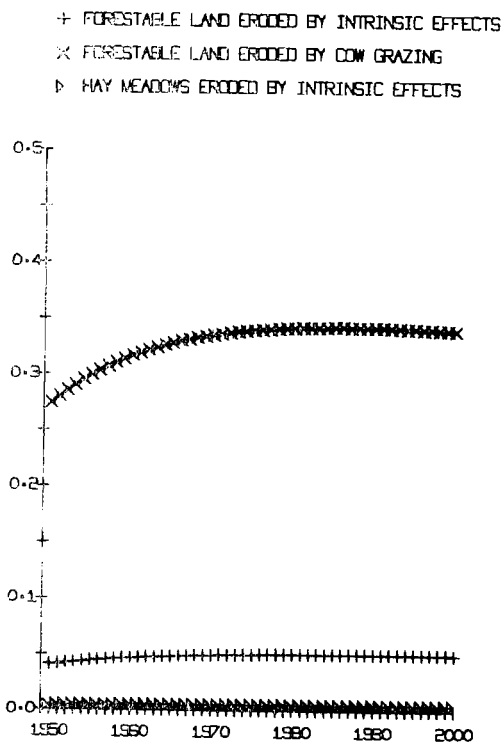
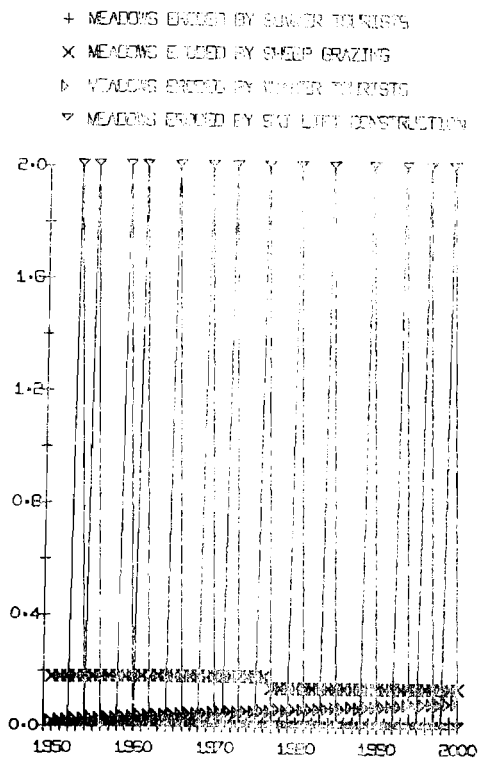
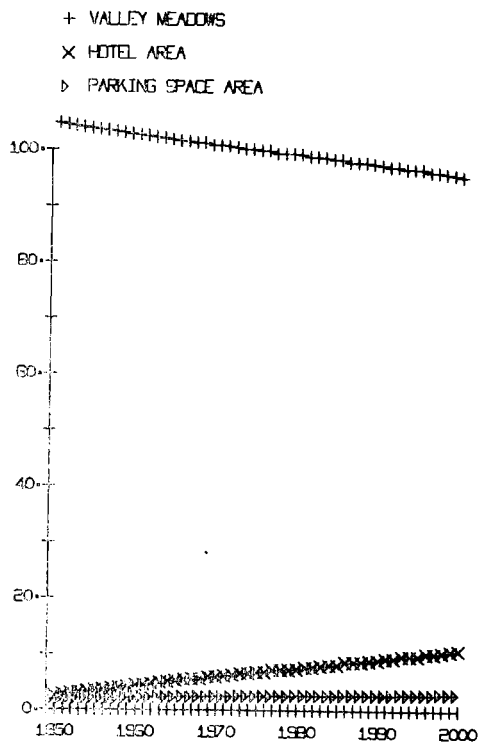
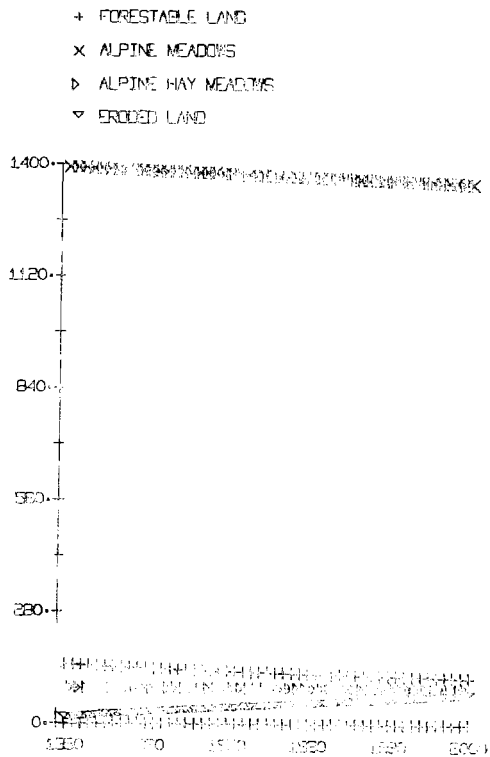

FIGURE 9

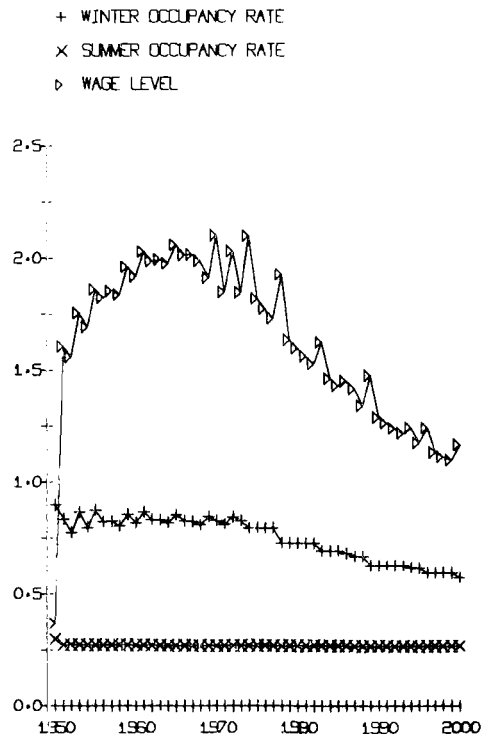
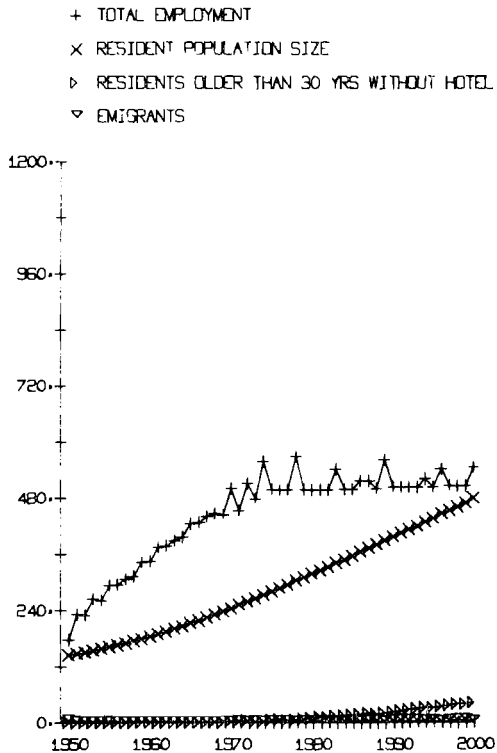
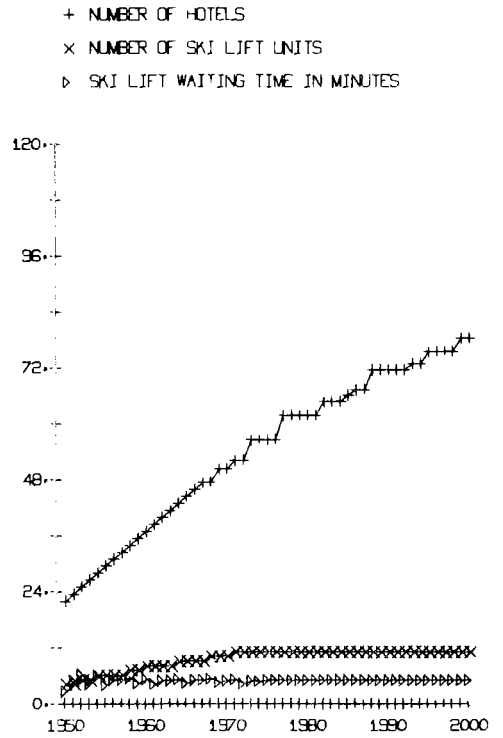
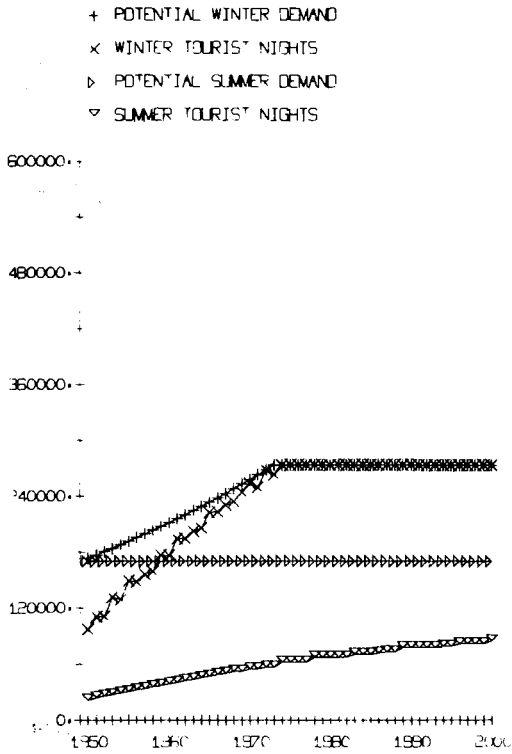
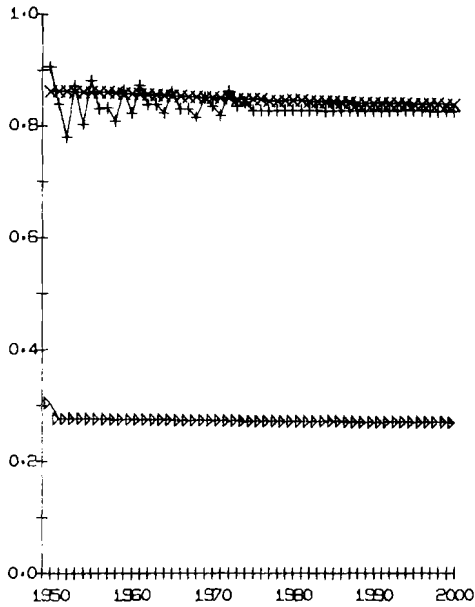
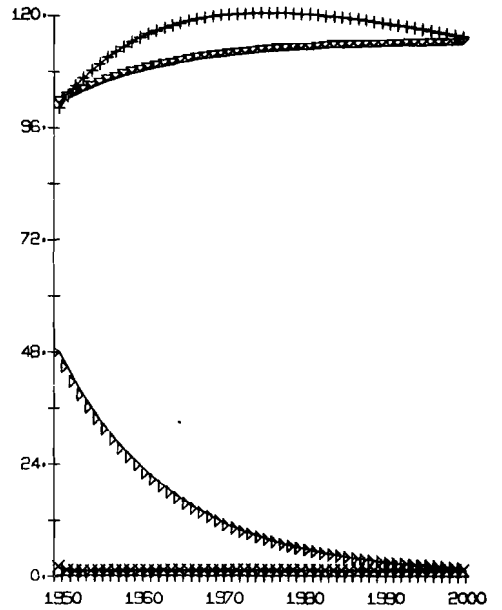

FIGURE 9

- + WINTER RECREATION QUALITY
- x SUMMER HABITAT DIVERSITY
- ▷ SUMMER RECREATION QUALITY



- + FORESTABLE LAND WITHOUT TREES
- x LAND WITH TREES 1-2 YEARS PAST PLANTING
- ▷ LAND WITH TREES 3-50 YEARS PAST PLANTING
- ▽ FORESTED LAND



- + NUMBER OF COWS
- x NUMBER OF RESIDENT SHEEP
- ▷ NUMBER OF HORSES
- ▽ NUMBER OF CHAMOIS

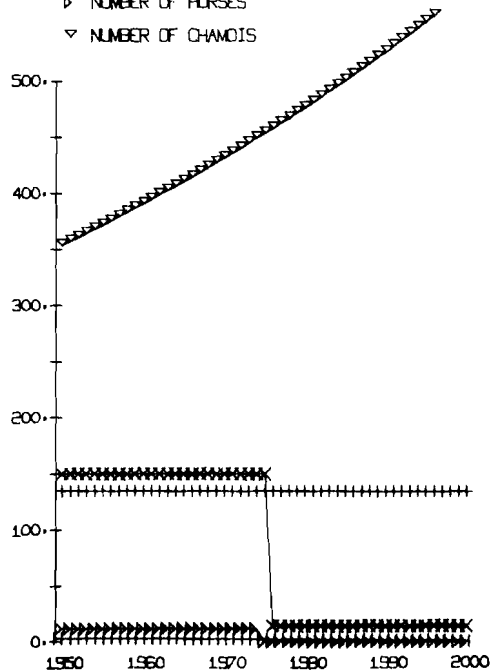

- + HAY PRODUCTION IN AREA
- x IMPORTED HAY

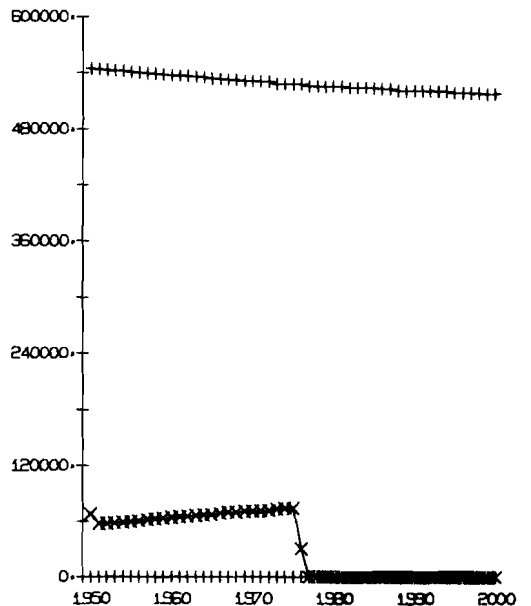



FIGURE 9

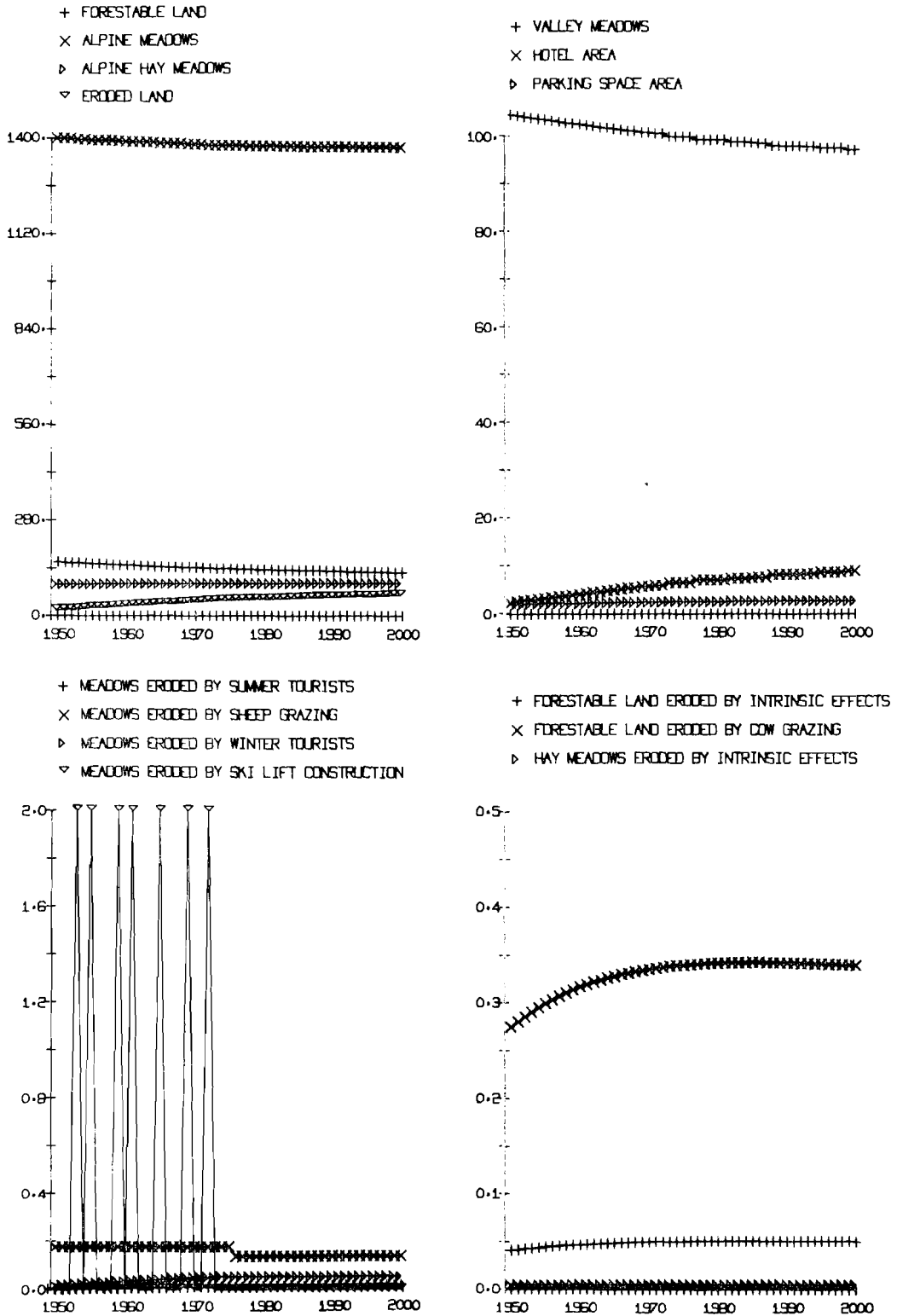

FIGURE 10

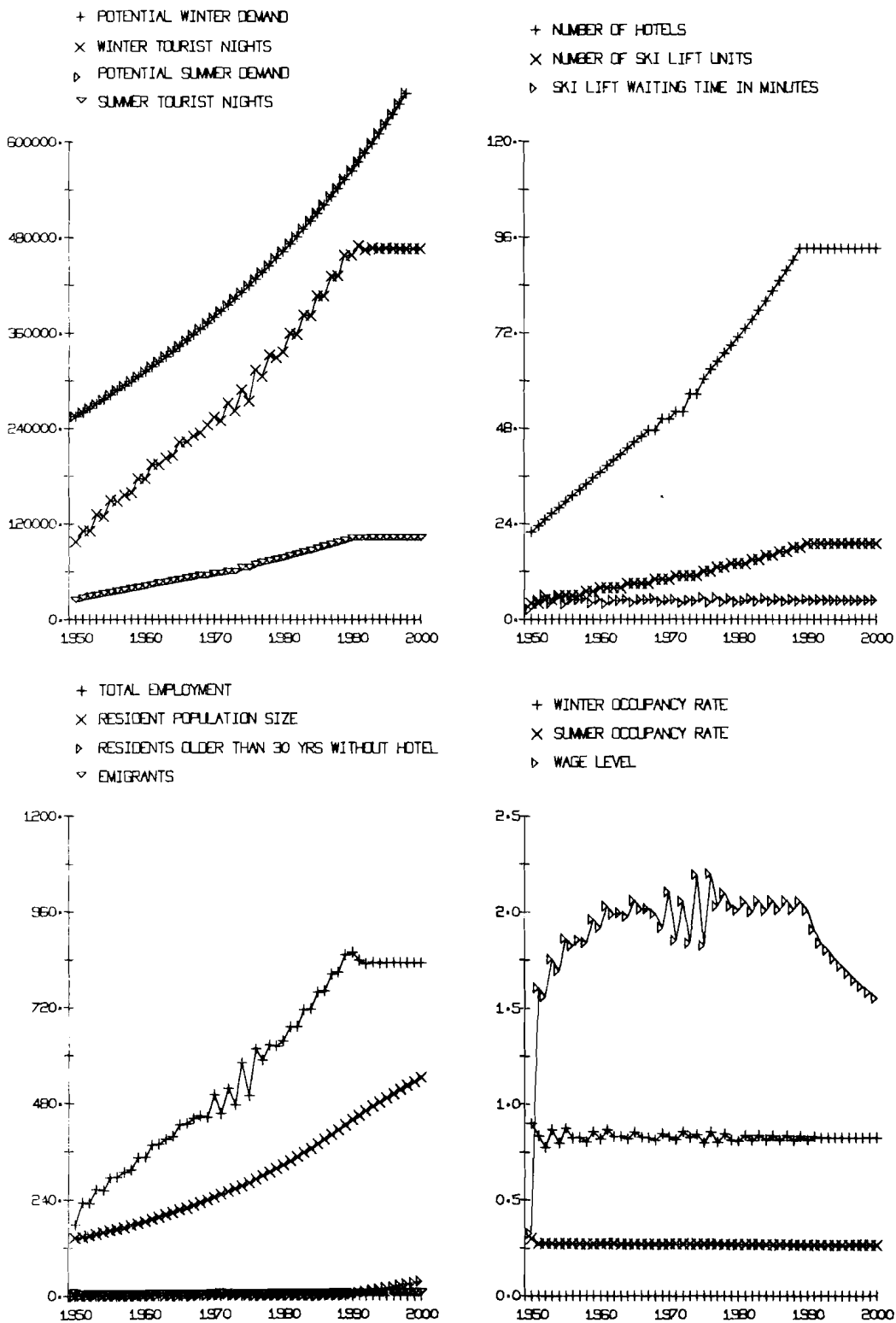

FIGURE 10

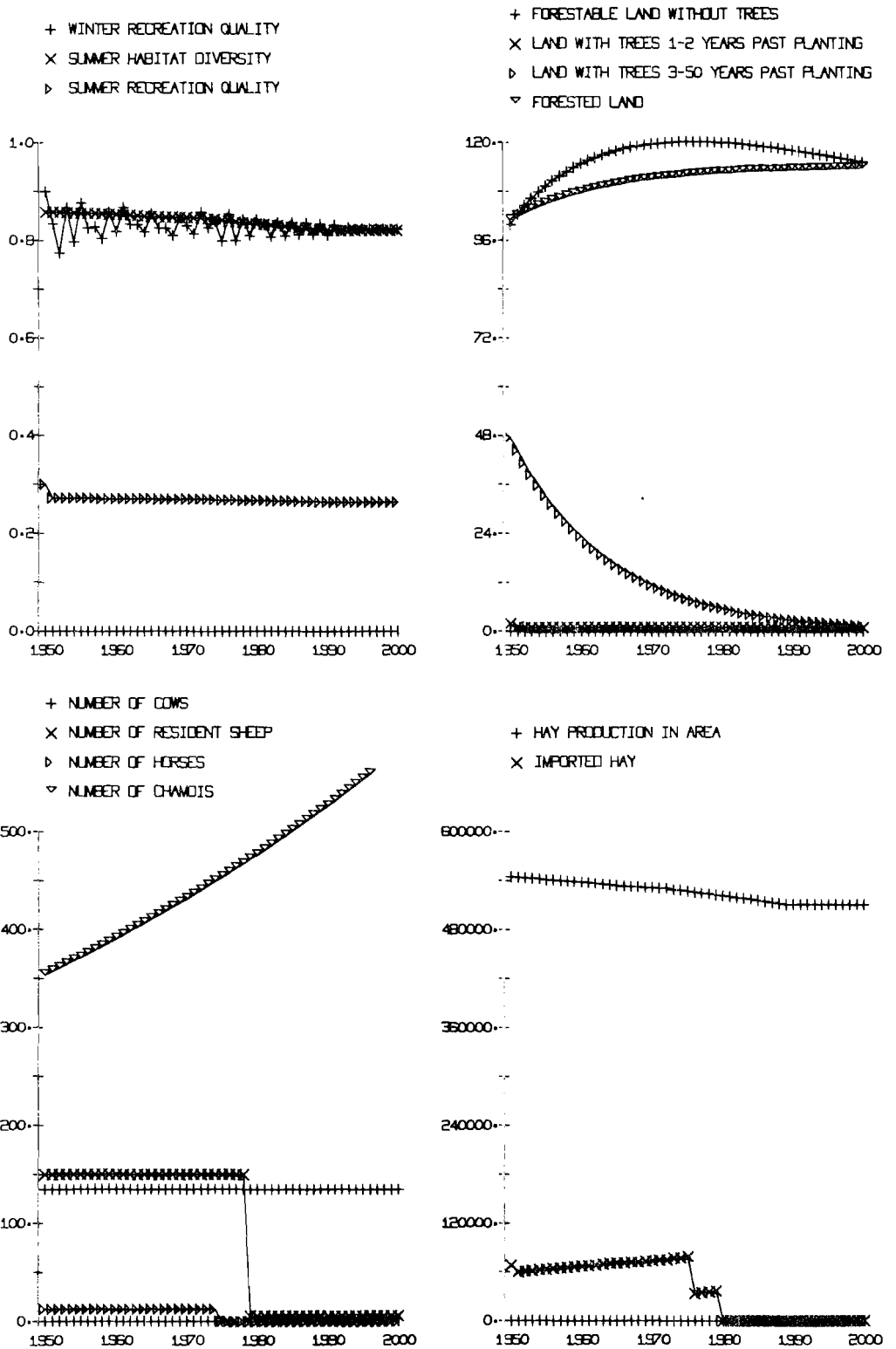

FIGURE 10

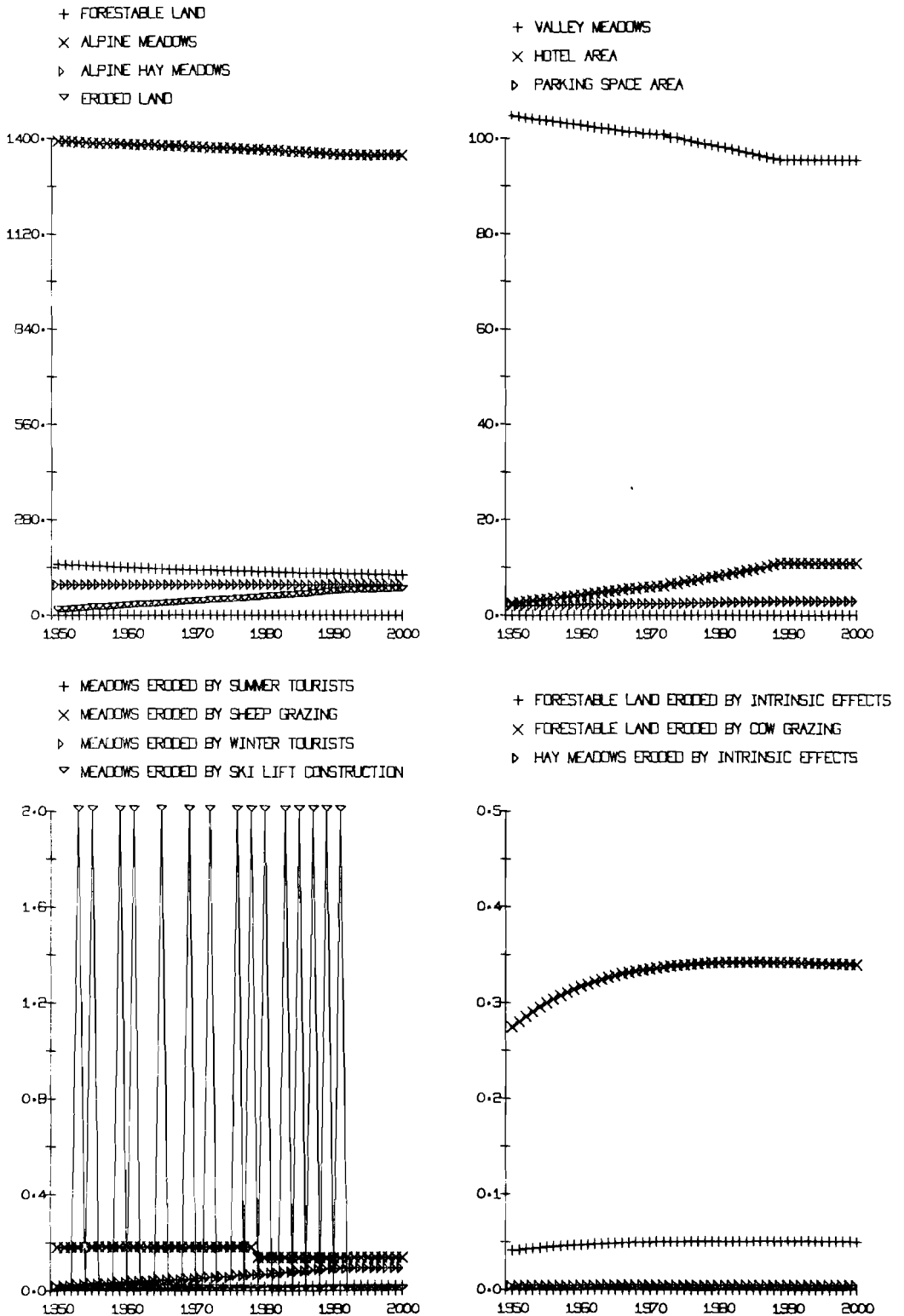

FIGURE 11

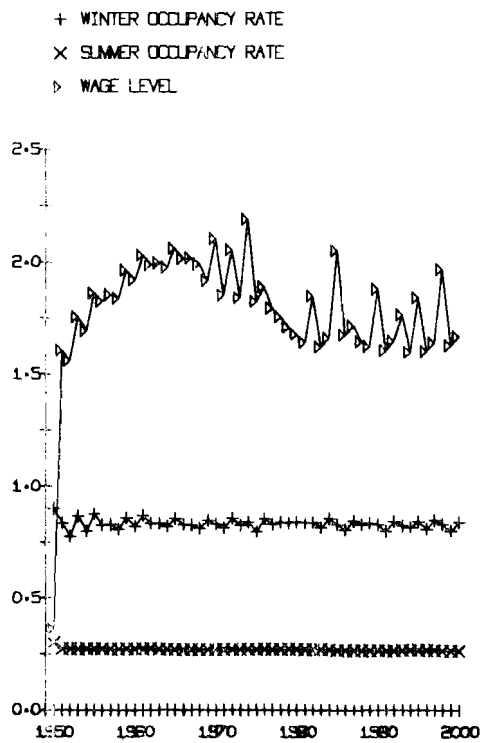
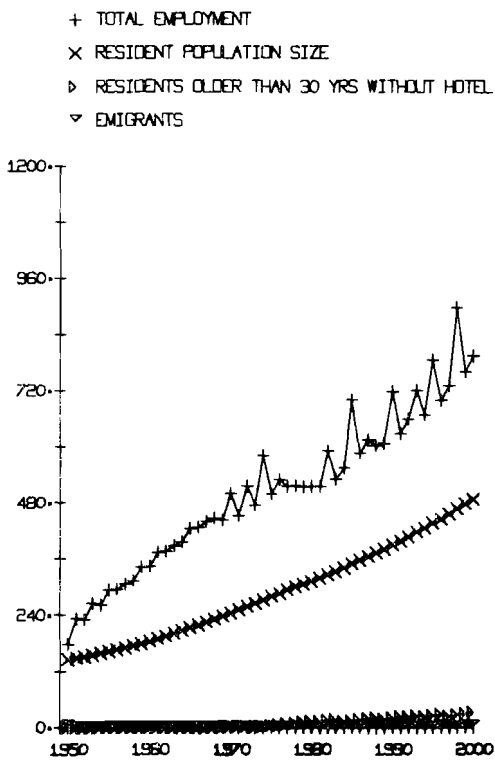
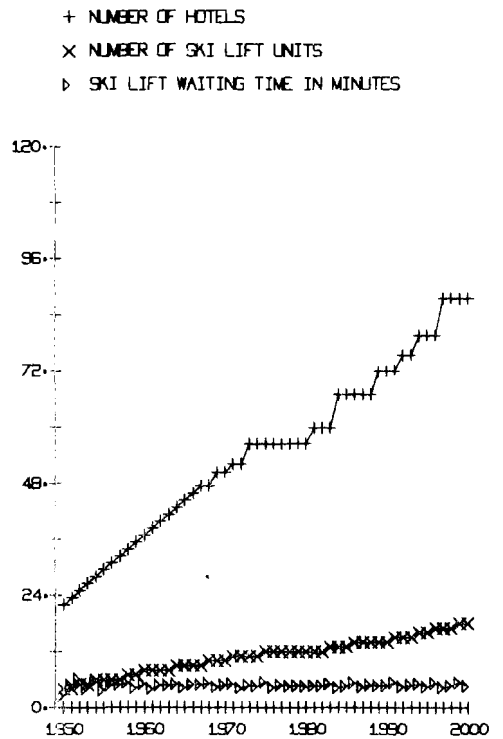
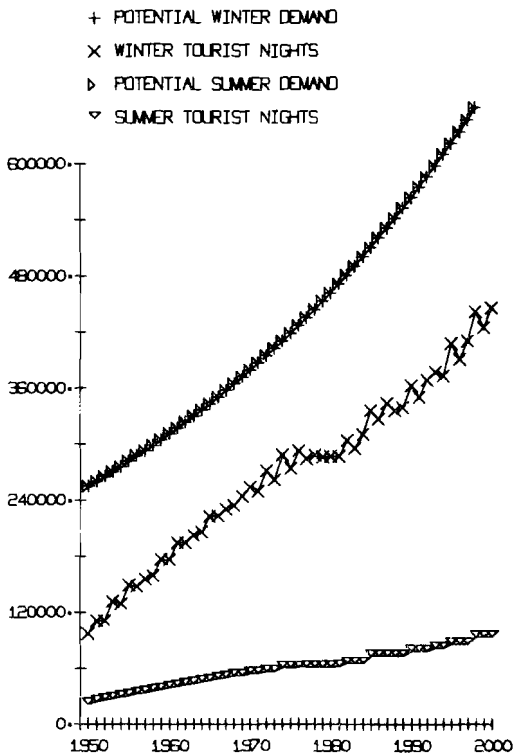

FIGURE 11

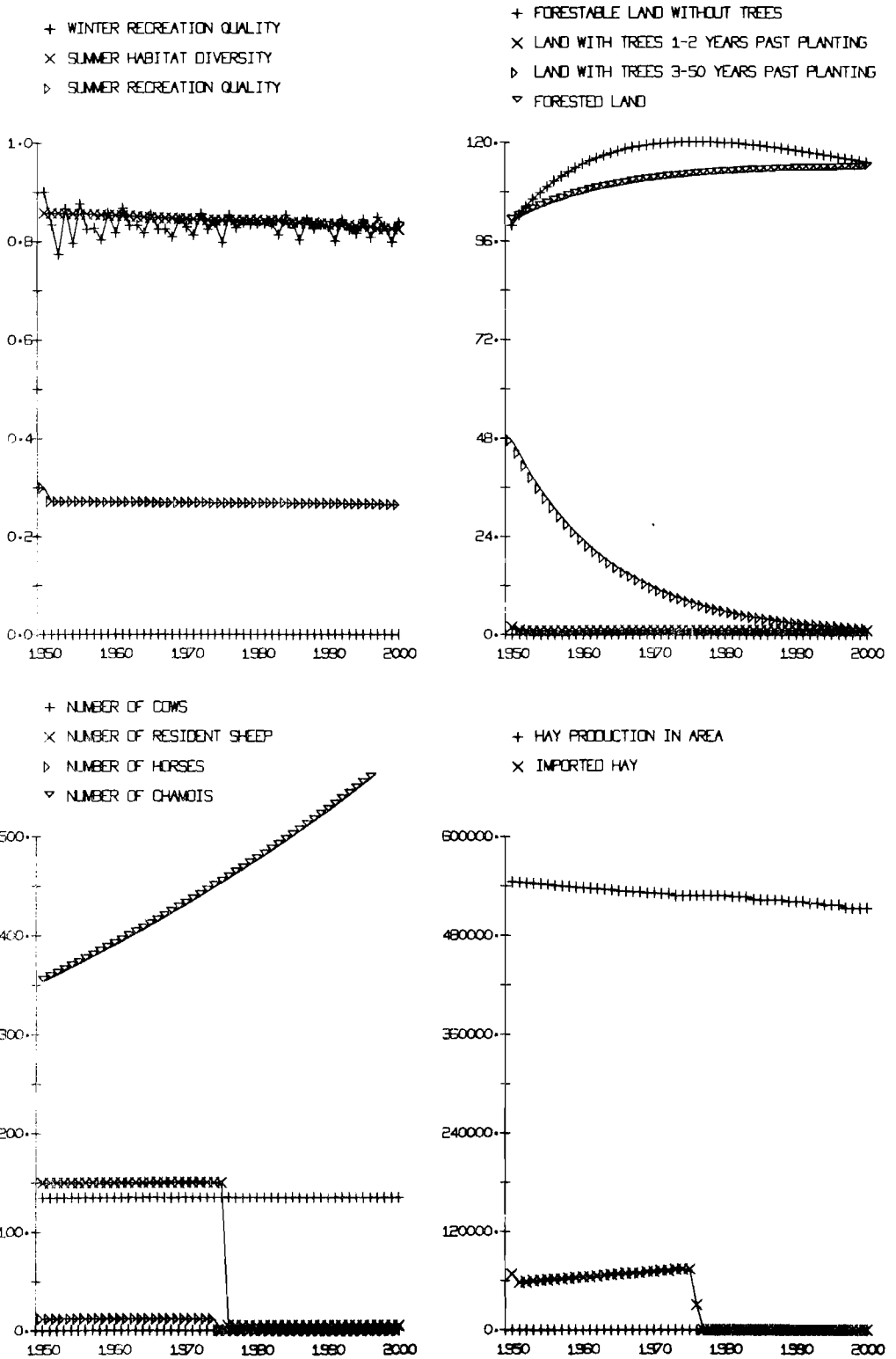

FIGURE 11

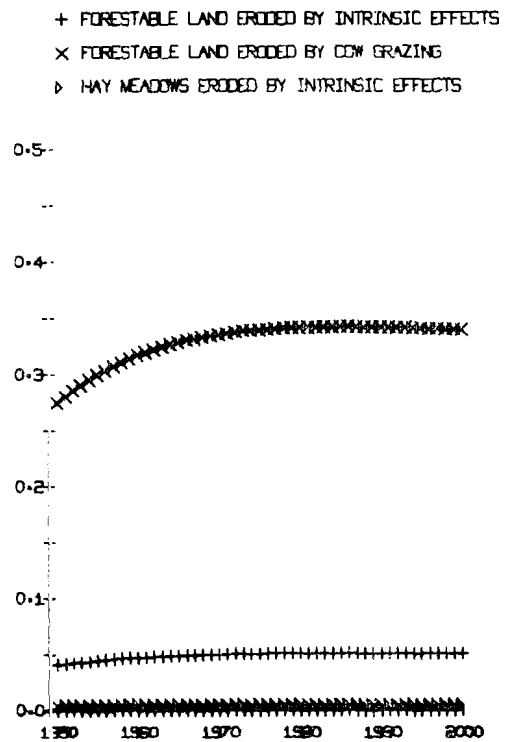
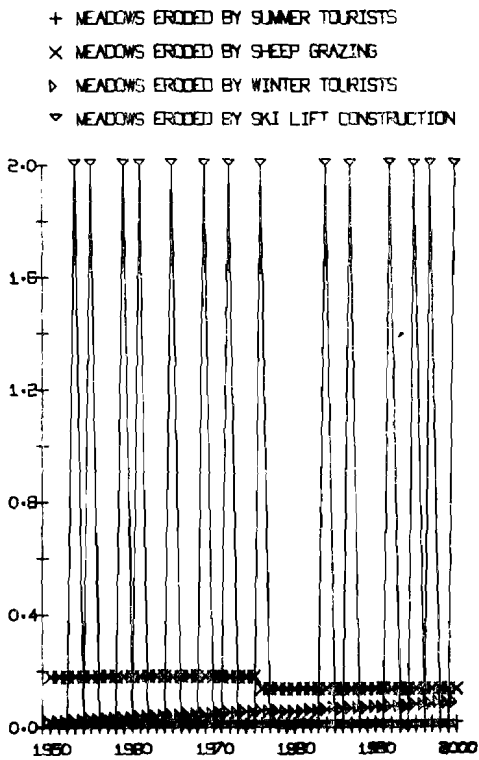
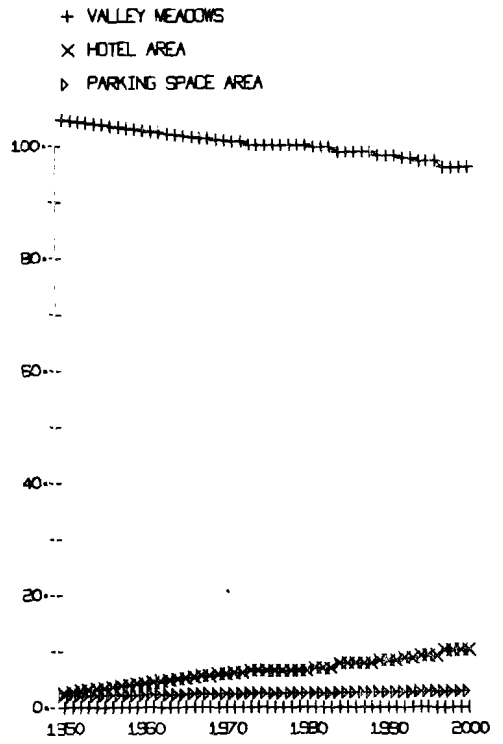
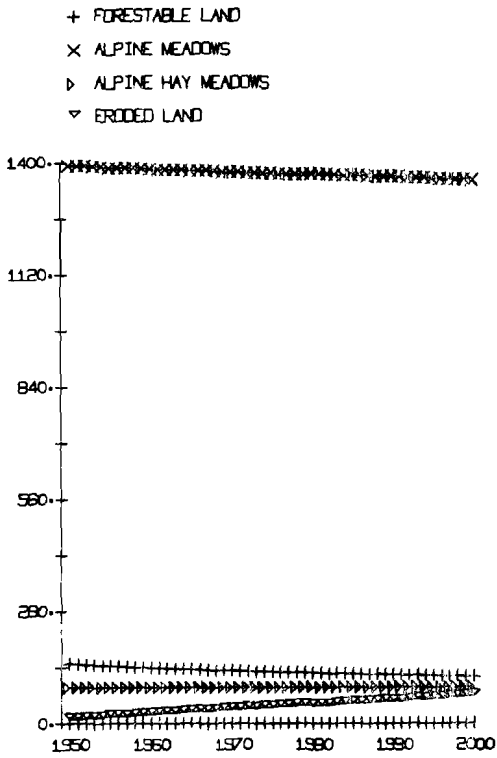

FIGURE 12

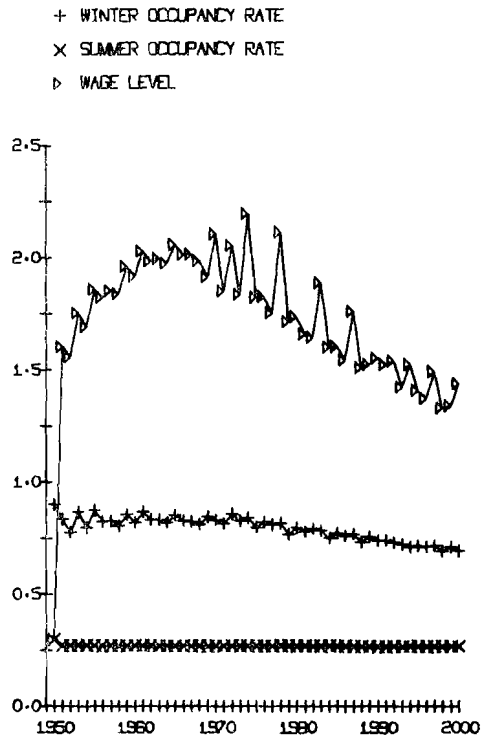
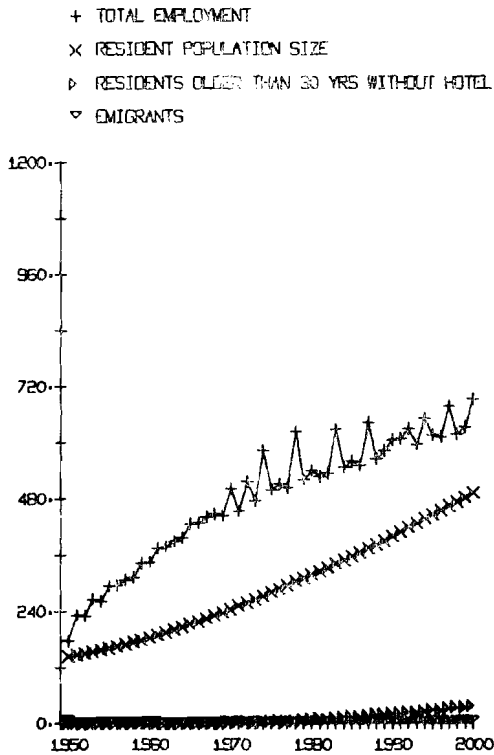
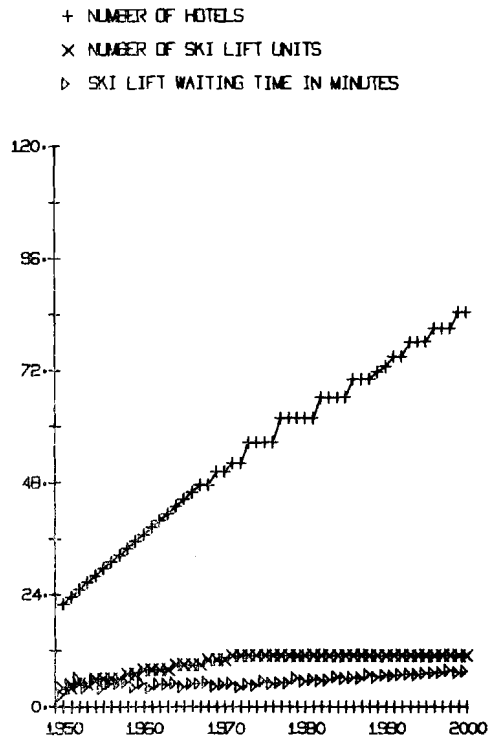
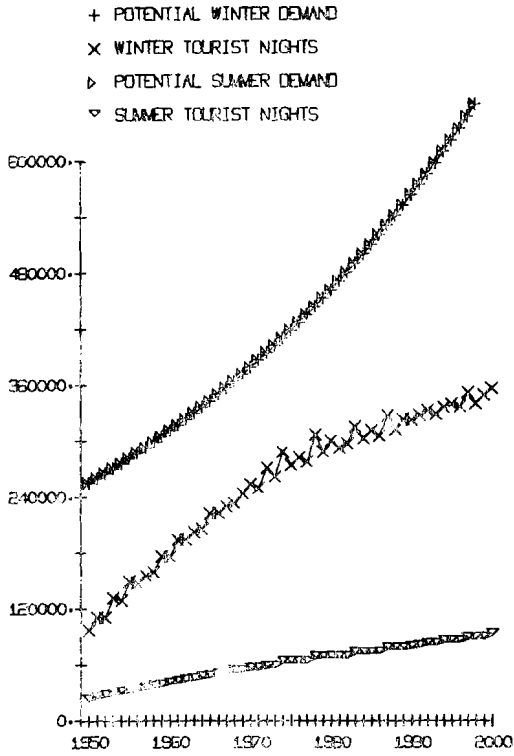



FIGURE 12

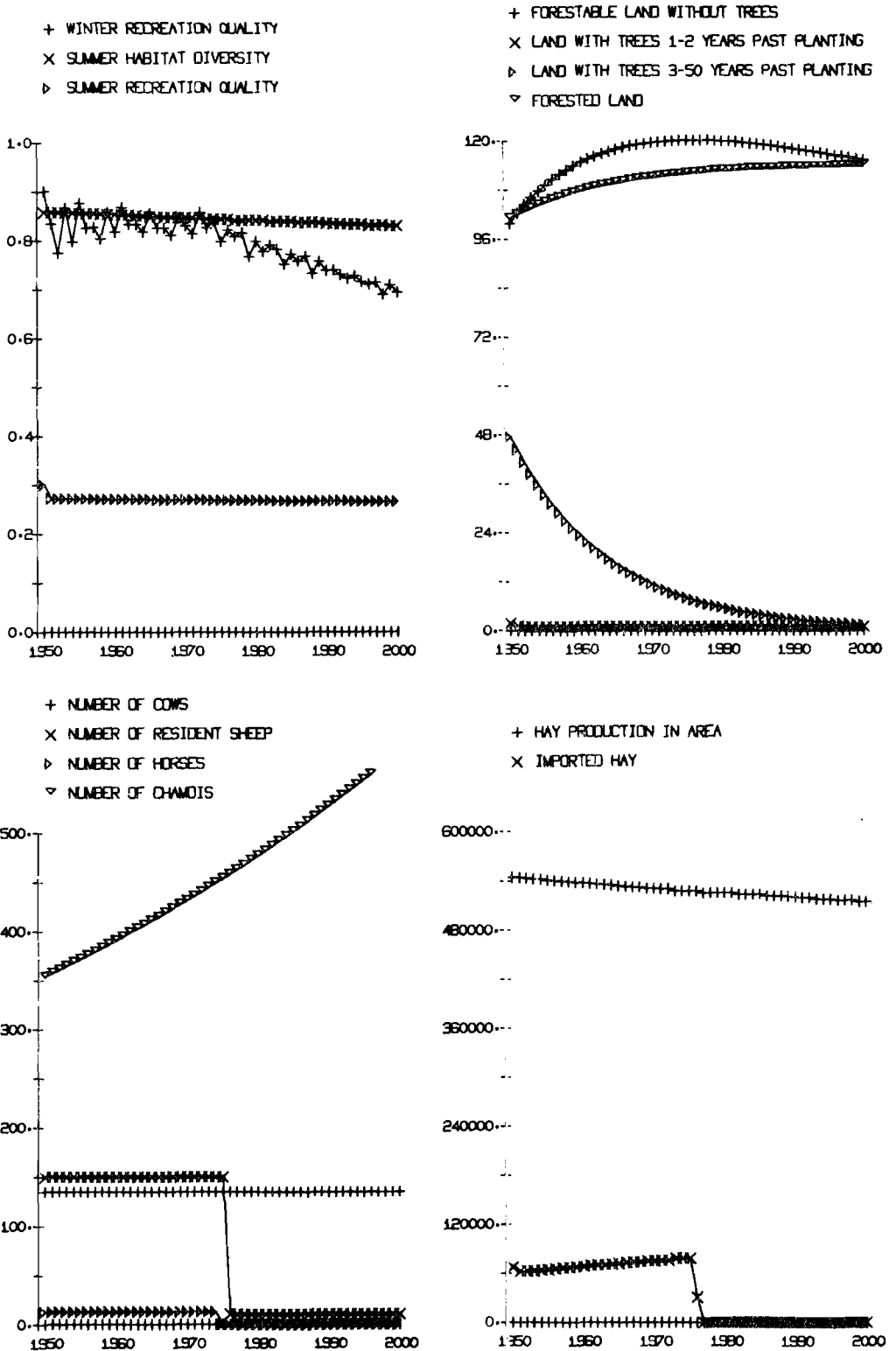

FIGURE 12

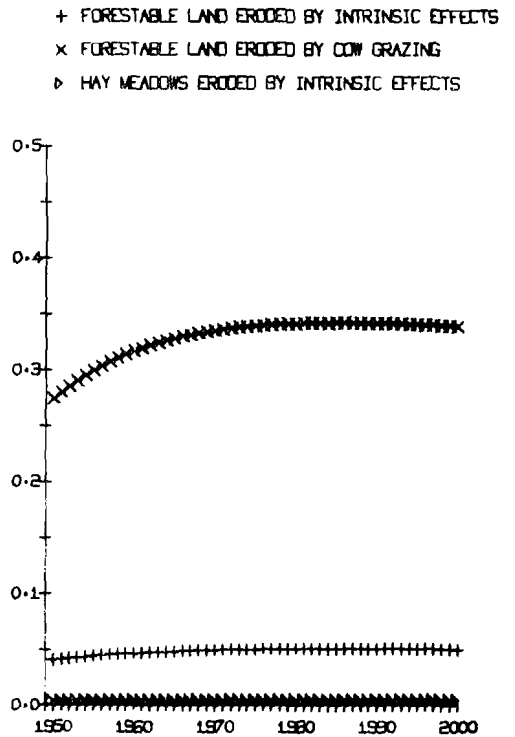
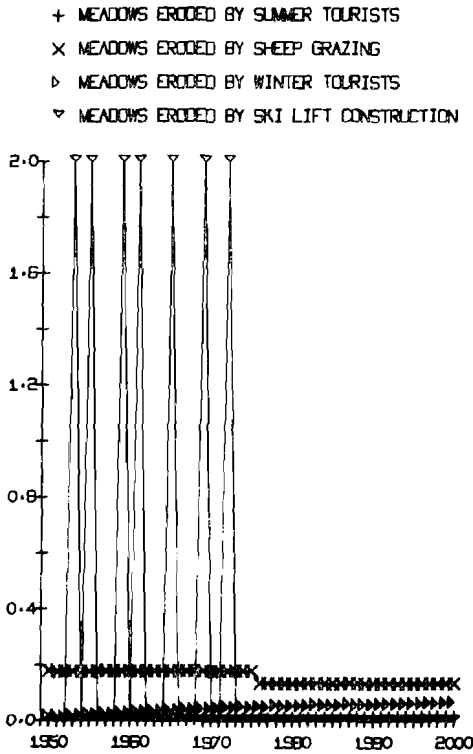
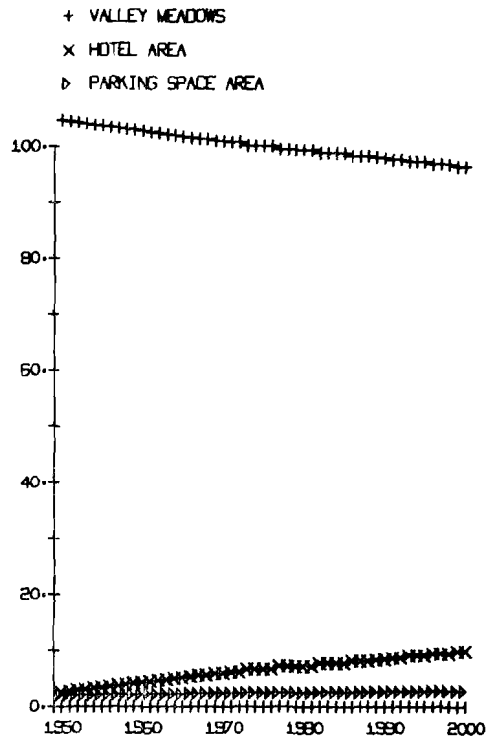
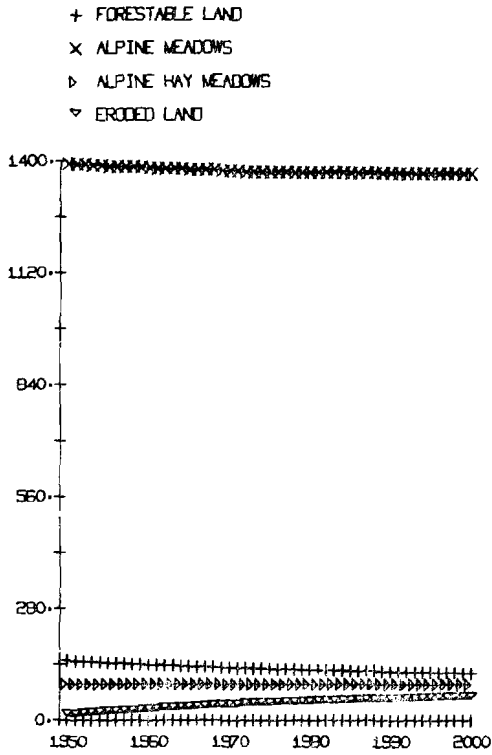

FIGURE 13

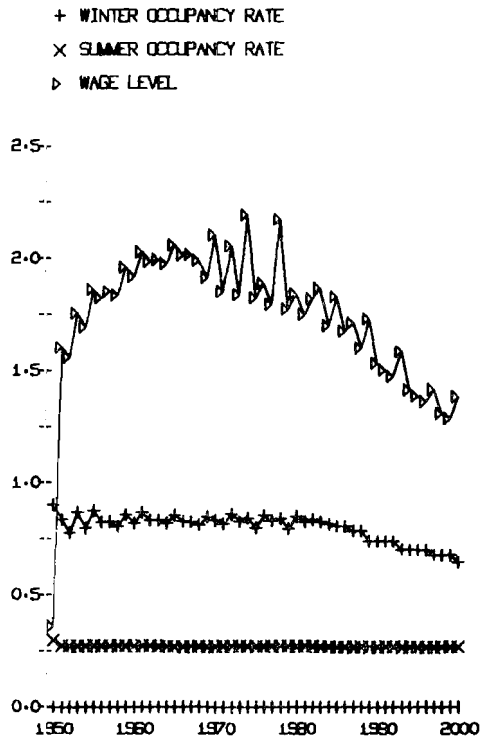
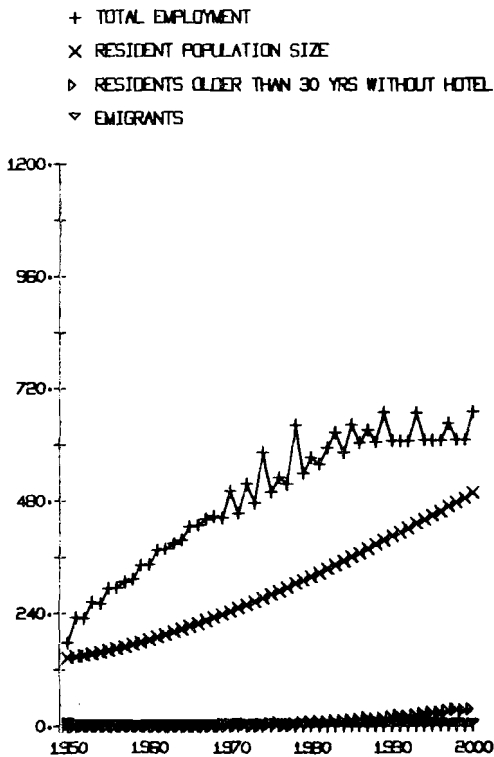
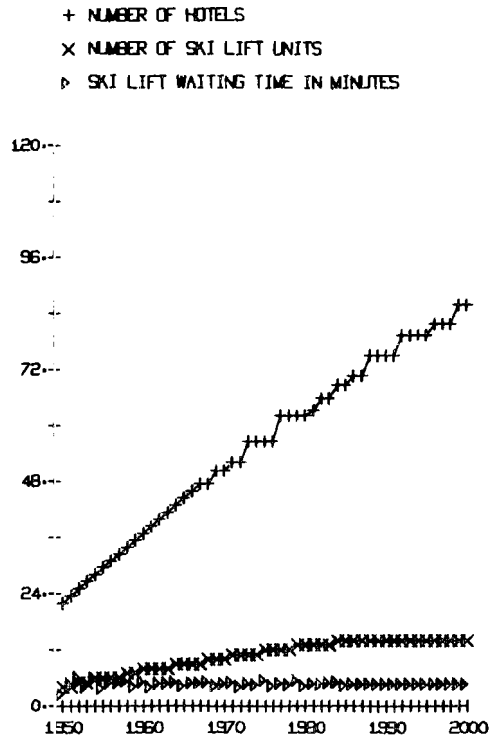
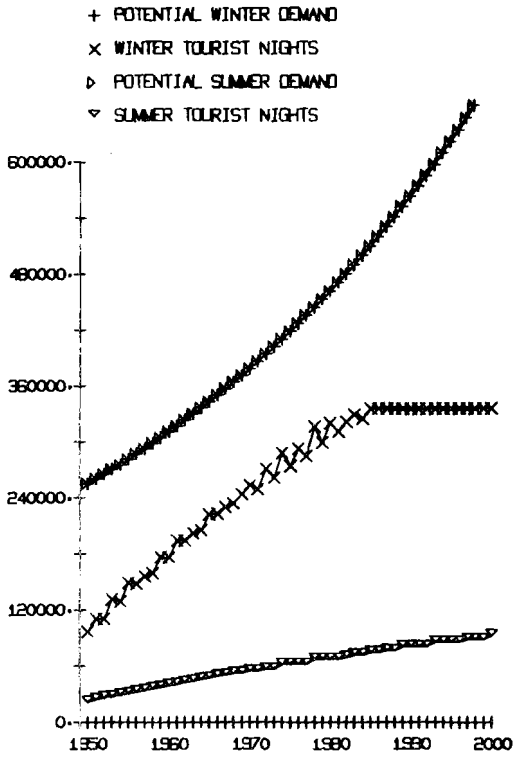

FIGURE 13

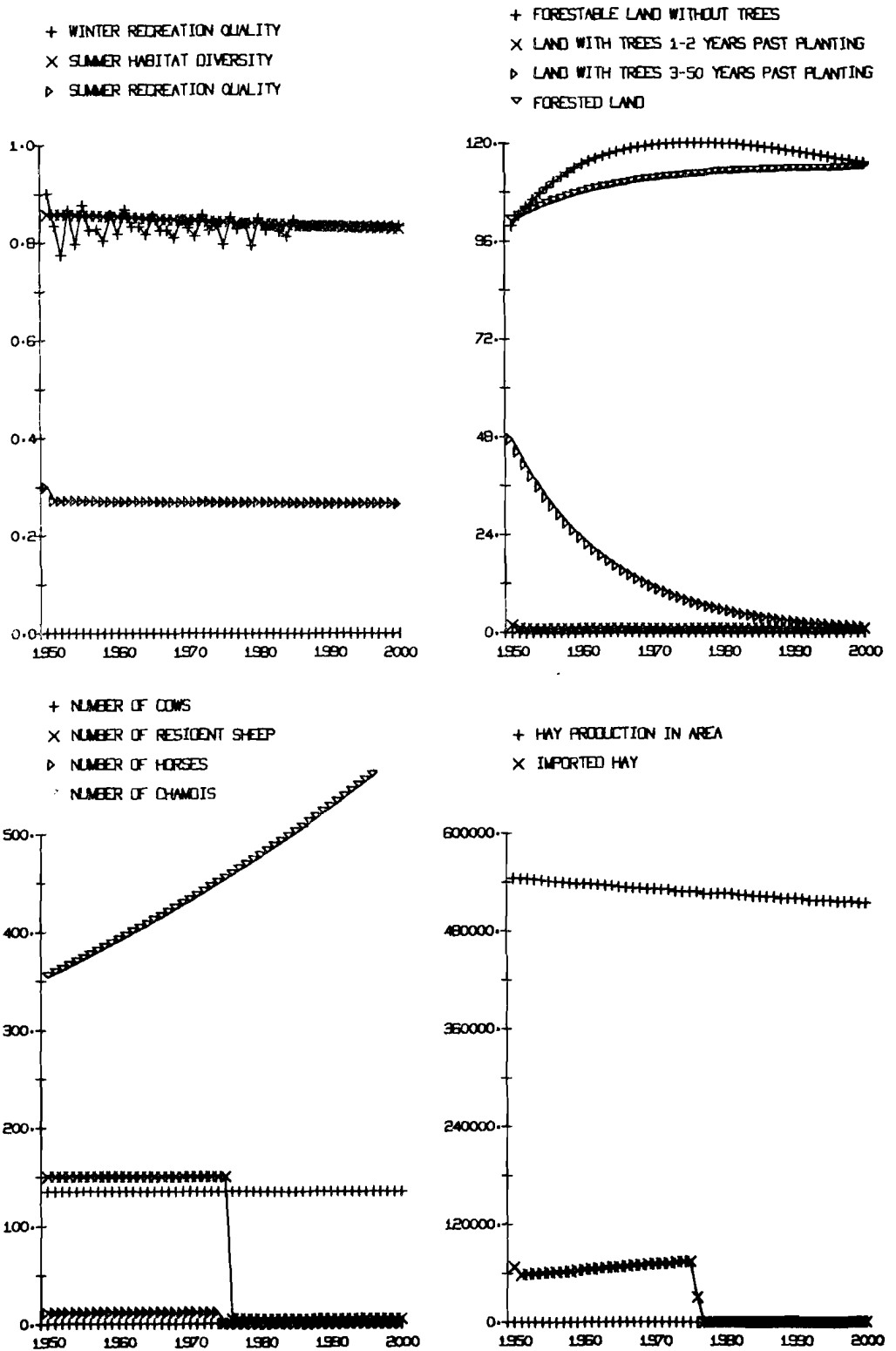

FIGURE 13

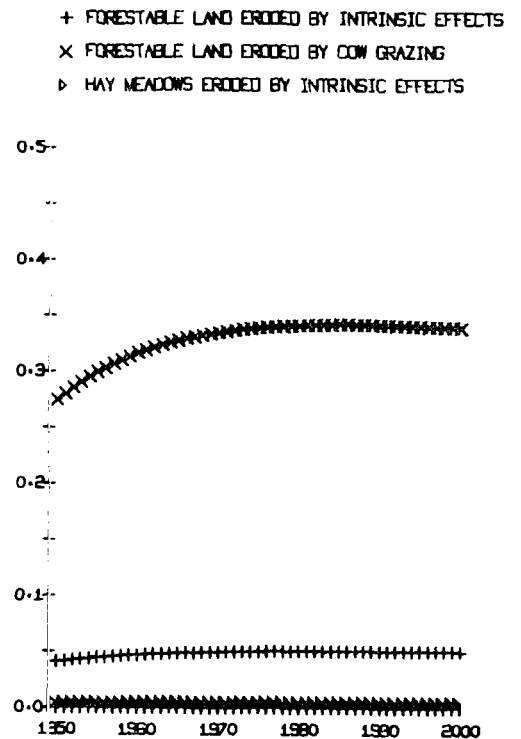
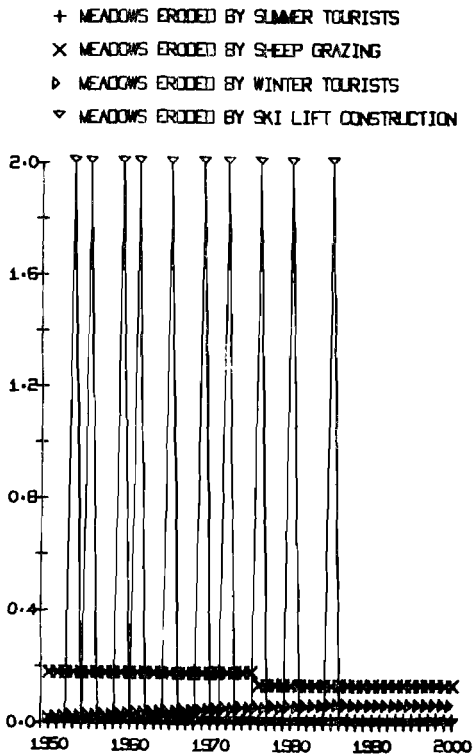
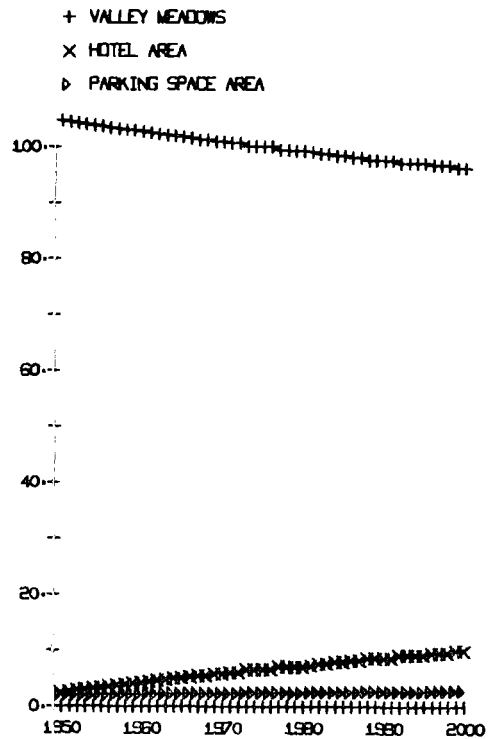
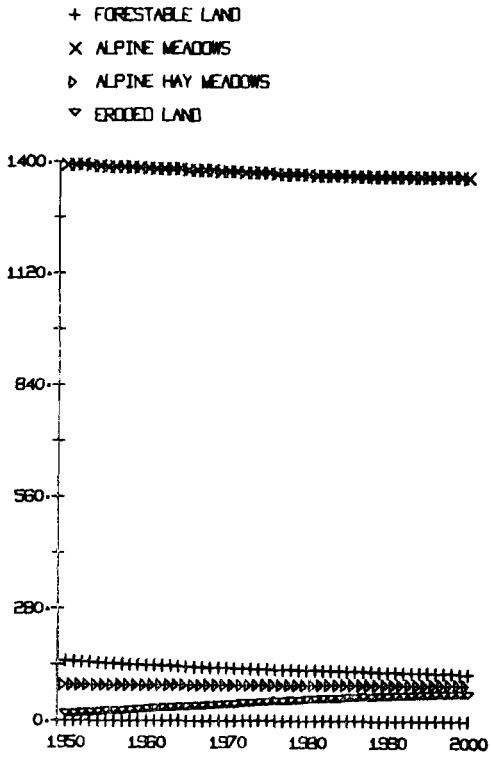

FIGURE 14

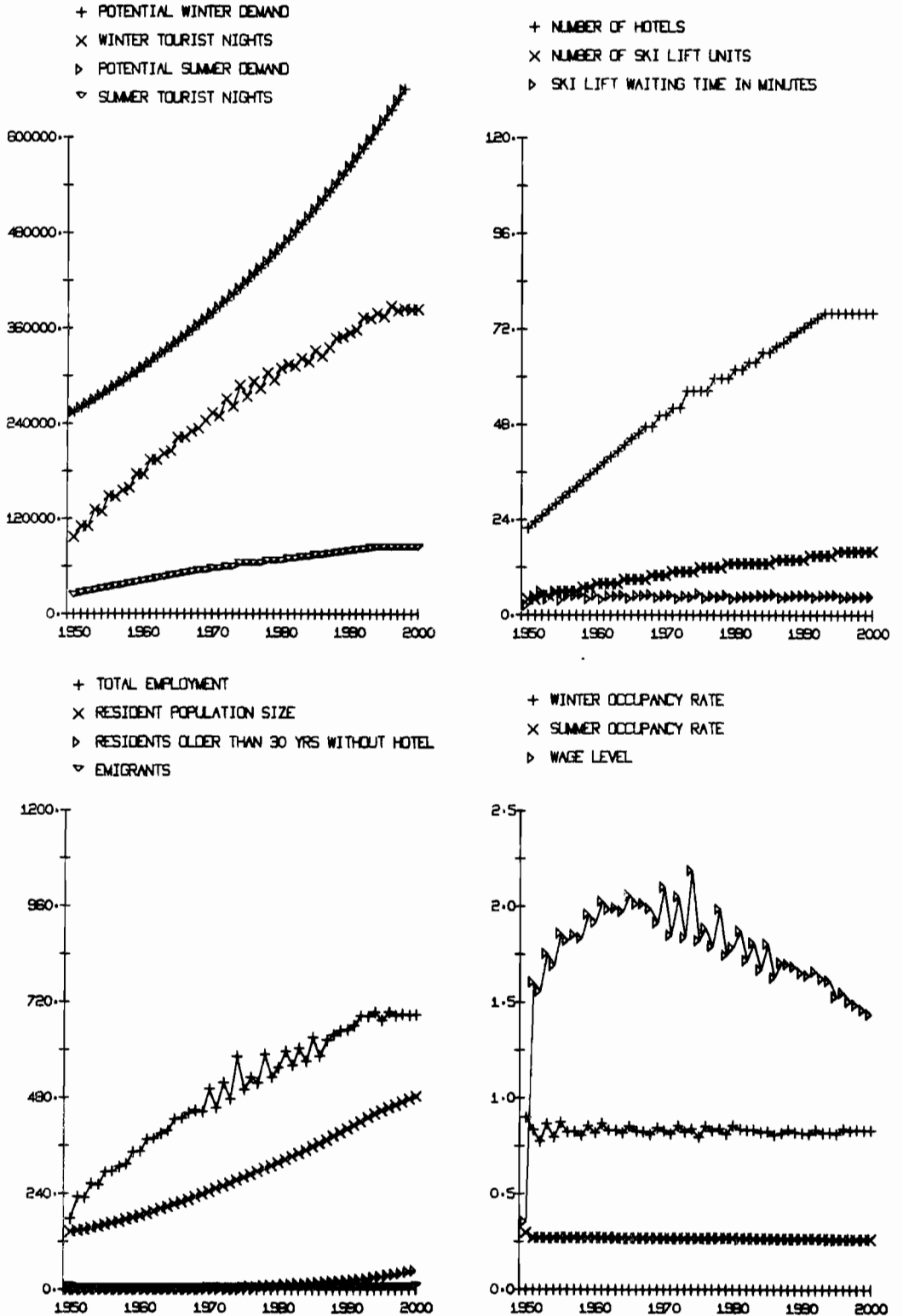

FIGURE 14

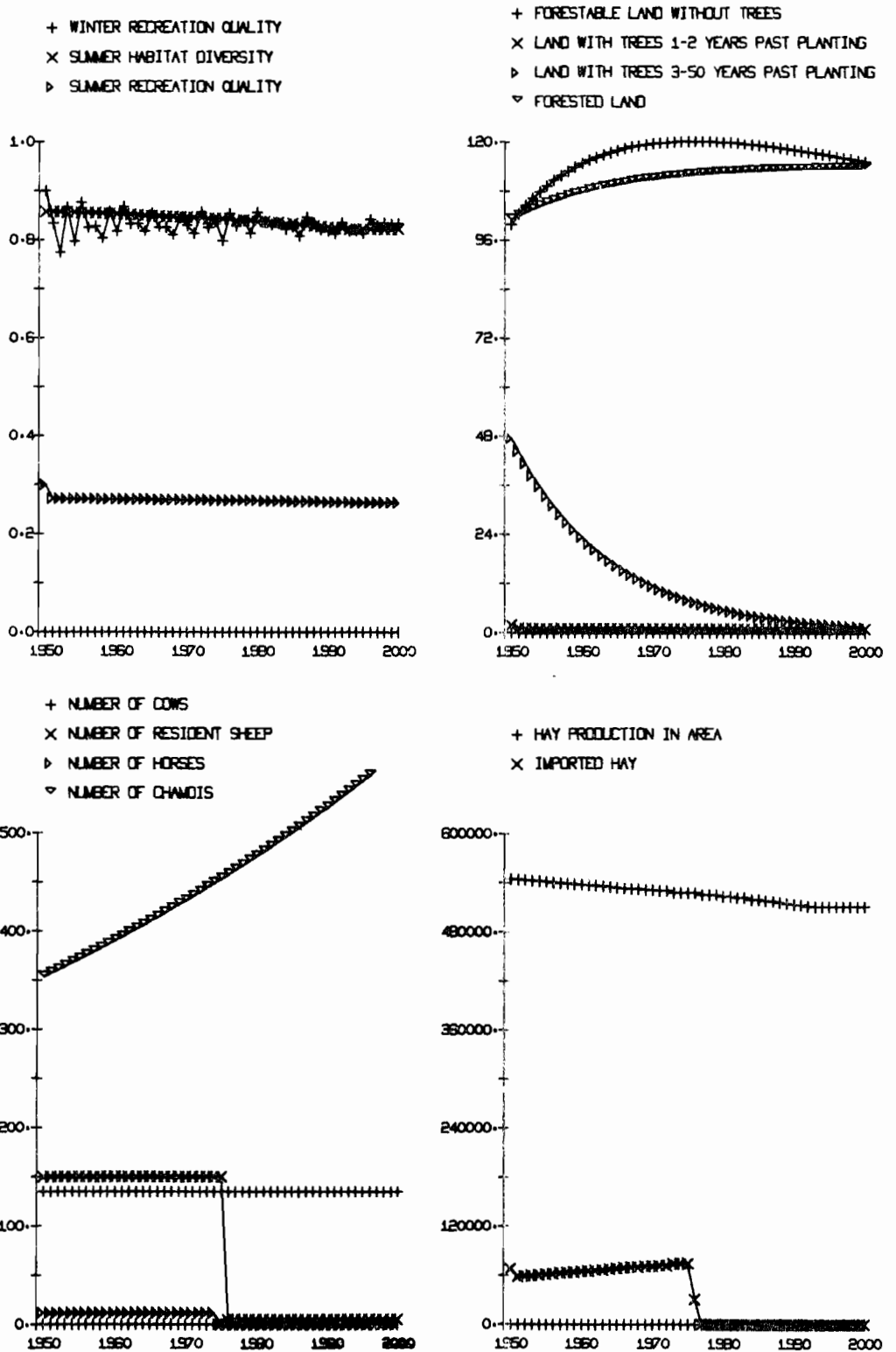
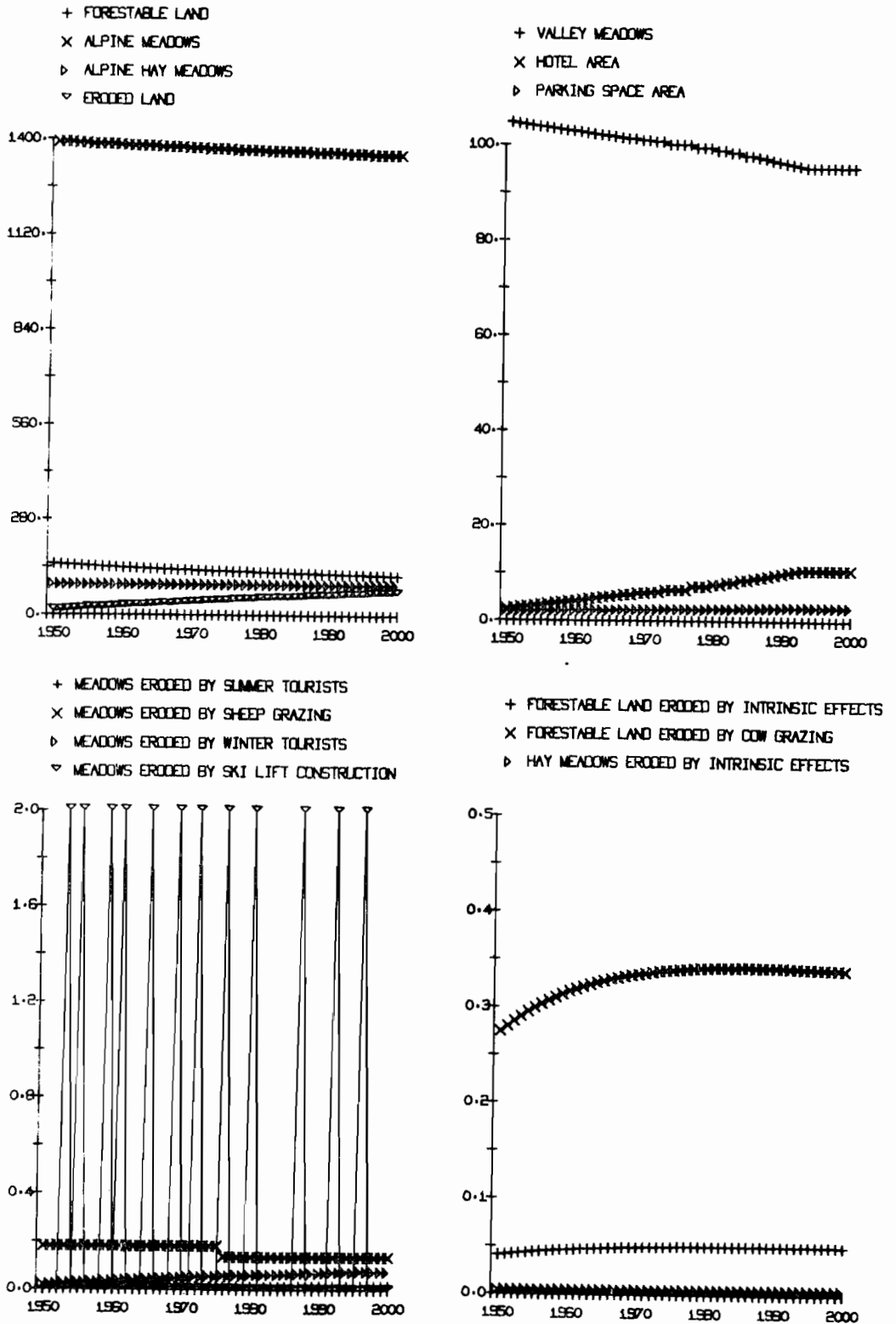

FIGURE 14





## APPENDIX A



APPENDIX A		(INITIAL) VALUE
VARIABLE	MEANING	
HOTEL	NUMBER OF HOTELS	20
ROOM	NUMBER OF BEDS	800
CLIFT	NUMBER OF SKI LIFT UNITS	4
AREA 1	HOTEL AREA	2.3
AREA 2	PAKING SPACE AREA	2
AREA 4	VALLEY MEADOWS	104.9
AREA 5	FORESTABLE LAND	150
AREA 6	FORESTED LAND	100
AREA 7	ALPINE MEADOWS	1400
AREA 8	ERODED LAND	2
AREA 9	ALPINE HAY MEADOWS	90
AREAT	TATOL AREA IN HECTARS	7269.5
FOR1	LAND WITH TREES 1-2 YEARS PAST PLANTING	5.0
FOR2	LAND WITH TREES 3-50 YEARS PAST PLANTING	50
STEEL	FORESTABLE LAND WITHOUT TREES	.95
POP 1	RESIDENT POPULATION 0-15 YEARS	41
POP 2	RESIDENT POPULATION 15-30 YEARS	56
POP 3	RESIDENT POPULATION 30-60 YEARS	40
POP 4	RESIDENT POPULATION OLDER THAN 60 YEARS	9
DMAXW	POTENTIAL WINTER DEMAND	250000
DMAXS	POTENTIAL SUMMER DEMAND	250000
WATER	CURRENT WATER SUPPLY	21
DIV	SUMMER HABITAT DIVERSITY	1
HORS	NUMBER OF HORSES	15
WILD	NUMBER OF CHAMOIS	350
COWS	NUMBER OF COWS	135
SHEEP	NUMBER OF SHEEP IN AREA	450
OSHEP	NUMBER OF RESIDENT SHEEP	150
DIVWA	RELATIVE DIVERSITY VALUE OF ALPINE MEADOWS	0.3
DIVWM	RELATIVE DIVERSITY VALUE OF MEADOWS	0.5
DIVWP	RELATIVE DIVERSITY VALUE OF FORESTS	0.2
WHAGRO	ECONOMIC GROWTH RATE	1.025
DMIN	MINIMUM LAND DIVERSITY TOLERATED	0
WMIN	MINIMUM WAGE LEVEL TOLERATED	0
BMAXP	MAXIMUM BUILDINGS PRESENT	1000
PMAXR	MAXIMUM POPULATION	10000
BMAXG	MAXIMUM BUILDING RATE	10
CLIFM	MAXIMUM SKI LIFTS PRESENT	100

CLIFA	MAXIMUM SKI LIFTS ADDED PER YEAR	1
TOLWT	TOLARBLE SKI LIFT WAITING TIME IN MUNUTES	5
PROVAD	REFORESTATION RATE	3.0
WATAD	PARKING SPACE ADDED WHEN NEEDED	0.04
WATCAP	WATER SUPPLY ADDED WHEN NEEDED	10
WATPER	MAXIMUM WATER SUPPLY	100
SUMPER	PEOPLE SUPPORTED PER UNIT WATER SUPPLY	16000
WINPER	TOURIST DAYS IN SUMMER SEASON	90
RPERM	TOURIST DAYS IN WINTER SEASON	135
PARK	BEDS PER ROOM	2
CARS	CARS PER HECTARE PARKING SPACE	833
WAITXX 1	CARS PER PERSON	0.5
WAITXX 2	X1 VALUE FOR WAIT FUNCTION	10000
WAITXX 3	X2 VALUE FOR WAIT FUNCTION	25000
WAITXX 4	X3 VALUE FOR WAIT FUNCTION	50000
WAITXX 5	X4 VALUE FOR WAIT FUNCTION	80000
WAITYY 1	X5 VALUE FOR WAIT FUNCTION	100000
WAITYY 2	Y1 VALUE FOR WAIT FUNCTION	0
WAITYY 3	Y2 VALUE FOR WAIT FUNCTION	5
WAITYY 4	Y3 VALUE FOR WAIT FUNCTION	15
WAITYY 5	Y4 VALUE FOR WAIT FUNCTION	20
WAITYY 6	Y5 VALUE FOR WAIT FUNCTION	30
Q2XX 1	Y6 VALUE FOR WAIT FUNCTION	50
Q2XX 2	X1 VALUE FOR DIVERSITY EFFECT FUNCTION	0
Q2XX 3	X2 VALUE FOR DIVERSITY EFFECT FUNCTION	0.5
Q2XX 4	X3 VALUE FOR DIVERSITY EFFECT FUNCTION	1.0
Q2XX 5	X4 VALUE FOR DIVERSITY EFFECT FUNCTION	2.0
Q2YY 1	X5 VALUE FOR DIVERSITY EFFECT FUNCTION	3.0
Q2YY 2	Y1 VALUE FOR DIVERSITY EFFECT FUNCTION	0
Q2YY 3	Y2 VALUE FOR DIVERSITY EFFECT FUNCTION	0.2
Q2YY 4	Y3 VALUE FOR DIVERSITY EFFECT FUNCTION	0.3
Q2YY 5	Y4 VALUE FOR DIVERSITY EFFECT FUNCTION	0.3
GUSP	Y5 VALUE FOR DIVERSITY EFFECT FUNCTION	0.3
DWGR	QUALITY OF SERVICES PROVIDED	1.0
DSGR	EXTERNAL WINTER DEMAND GROWTH RATE	1.02
QW3XX 1	EXTERNAL SUMMER DEMAND GROWTH RATE	1.02
QW3XX 2	X1 VALUE OF FUNCTION WAIT TIME ON QUALITY	0
QW3XX 3	X2 VALUE OF FUNCTION WAIT TIME ON QUALITY	5
QW3XX 4	X3 VALUE OF FUNCTION WAIT TIME ON QUALITY	10
	X4 VALUE OF FUNCTION WAIT TIME ON QUALITY	20

QW3XX	5	X5	VALUE OF FUNCTION	WAIT	TIME ON QUALITY	40
QW3YY	1	Y1	VALUE OF FUNCTION	WAIT	TIME ON QUALITY	0.9
QW3YY	2	Y2	VALUE OF FUNCTION	WAIT	TIME ON QUALITY	0.9
QW3YY	3	Y3	VALUE OF FUNCTION	WAIT	TIME ON QUALITY	0.85
QW3YY	4	Y4	VALUE OF FUNCTION	WAIT	TIME ON QUALITY	0.7
QW3YY	5	Y5	VALUE OF FUNCTION	WAIT	TIME ON QUALITY	0.4
TW			MAN YEAR TOUR.	EMPLOYMENT/WINTER	TOURIST NIGHT	0.0016
TS			MAN YEAR TOUR.	EMPLOYMENT/SUMMER	TOURIST NIGHT	0.0006
APERH			AREA FOR ONE HOTEL	IN HECTARES		0.13
ROOMS			NUMBER OF BEDS	PER HOTEL		45.0
CONSTR			MAN YEARS CONSTRUCTION	EMPLOYMENT / HOTEL		13.4
FARM			MAN YEARS FARMING	EMPLOYMENT/ANIMAL IN FARMING		0.03
SERV			MAN YEARS SERVICE	EMPLOYMENT/ BASIC JOB		0.03
SUBSS			MAN YEARS EMPLOYMENT	FOR SUBSISTENCE		0.3
BRATE			BIRTH RATE OF FAMILIES	WITH HOUSE / YEAR		0.15
DRATE			DEATH RATE FOR POPULATION	OLDER THEN 60 YEARS		0.005
X1R	1		HOTEL COST	FN		0
X2R	2		HOTEL COST	FN		0.5
X3R	3		HOTEL COST	FN		1.0
X4R	4		HOTEL COST	FN		1.01
COST	1					2.5
COST	2					5.0
COST	3					10.0
COST	4					2000
SO	1		SERVICE QUALITY	FN		0.2
SO	2		SERVICE QUALITY	FN		1.0
SO	3		SERVICE QUALITY	FN		1.0
SO	4		SERVICE QUALITY	FN		0.8
PPOLD			PERCENTAGE OF OLD PEOPLE	IN OWNER CLASS		0.2
GROWB			ANNUAL GRASS GROWTH RATE	IN VALLEY MEADOWS		3700
GROWA			ANNUAL GRASS GROWTH RATE	IN ALPINE MEADOWS		1750
CEAT			KG OF FORAGE / COW UNIT	/ WINTER		3600
GRAZ			PORTION OF YEAR RESIDENT	SHEEP GRAZE IN MEADOWS		0.42
SEAT			PORTION OF YEAR FOREIGN	SHEEP GRAZE IN MEADOWS		0.27
SEAT			KG OF FORAGE / SHEEP	/ YEAR		730
WGMAX			BIRTH RATE OF CHAMOIS			0.18

WDIE		DEATH RATE OF CHAMOIS	0.10
WKILL		HARVEST RATE OF CHAMOIS	0.07
WNIB1		HA OF YOUNG FOREST KILLED / CHAMOIS	0.0
WNIB2		HA OF OLDER FOREST KILLED / CHAMOIS	0.0
FGRO1		TRANSFER RATE OF YOUNG TREES	0.50
FGRO2		TRANSFER RATE OF OLDER TREES TO FOREST	0.02
FDIE1		HA OF YOUNG TREES DAMAGED / COW / YEAR	0.01
FDIE2		DEATH RATE OF YOUNG TREES	0.50
FRAT		DEATH RATE OF OLDER TREES	0.05
FRAT		MAX AREA TRANSFERED FROM FORESTABLE TO ERODED/Y	0.1
HRAT		MAX AREA TRANSF. FROM VALLEY MEADOW TO ERODED/Y	0.01
ERSU		EROSION OF HAY MEADOWS / SUMMER TOURIST	.0000002
ERWU		EROSION OF HAY MEADOWS / WINTER TOURIST	.0000002
SEMAX		MAX MEADOWS AREA ERODED PER SHEEP OVERGRAZING	0.0003
WHAX	1	WAGE LEVEL AT WHICH NO HAY CAN BE IMPORTED	0.2
WHAX	2	WAGE LEVEL AT WHICH HAY IMPORT IS FIRST REDUCED	1.0
WHAY	1	HAY PURCHASE MULTIPLIER 1	0.0
WHAY	2	HAY PURCHASE MULTIPLIER 2	1.0
CAPDAY		DAY TRIPPERS IN WINTER	200
GW4XX	1	X1 VALUE OF FUNCTION CROWDING EFFECT ON SLOPES	0
GW4XX	2	X2 VALUE OF FUNCTION CROWDING EFFECT ON SLOPES	20000
GW4XX	3	X3 VALUE OF FUNCTION CROWDING EFFECT ON SLOPES	80000
GW4XX	4	X4 VALUE OF FUNCTION CROWDING EFFECT ON SLOPES	90000
GW4XX	5	X5 VALUE OF FUNCTION CROWDING EFFECT ON SLOPES	100000
GW4YY	1	Y1 VALUE OF FUNCTION CROWDING EFFECT ON SLOPES	1.0
GW4YY	2	Y2 VALUE OF FUNCTION CROWDING EFFECT ON SLOPES	1.0
GW4YY	3	Y3 VALUE OF FUNCTION CROWDING EFFECT ON SLOPES	0.0
GW4YY	4	Y4 VALUE OF FUNCTION CROWDING EFFECT ON SLOPES	0.0
GW4YY	5	Y5 VALUE OF FUNCTION CROWDING EFFECT ON SLOPES	0.0
EROL		EROSION EFFECTS	1.0
RECOV		HECTARES OF MEADOW RECOVERED FROM EROSION /YEAR	0.001
IGRAZ		SWITCH SHEEP EROSION PROPORTIONAL TO OVERGRAZIN	1
TERX	1	PERCENT ERODED WHEN SUMMER TOURISTS STOP COMING	0.05
TERX	2	PERCENT ERODED WHEN NO MORE TOURISTS COMING	0.20
TERY	1	SUMMER TOURIST REDUCTION MULTIPLIER 1	1.0
TERY	2	SUMMER TOURISTS REDUCTION MULTIPLIER 2	0.1
ERSK		HECTARES ERODES PER NEW LIFT UNIT	2.0
CMAX		MAXIMUM AREA ERODED PER COW	0.005
IPIND		INDEX OF SOMETHING I CAN'T READ	4

ALFA					0.01
PEMIG					0.5
CR	1				0
CR	2				0.75
CR	3				1.50
CR	4				1.00
DIFF					0.75
SAVE					3.0
PWANT					1.0
AMAXH					13.9
PPARK					0.1
YOGOX	1			X1 VALUE	0.1
YOGOX	2			X2 VALUE	0.2
YOGOX	3			X3 VALUE	0.3
YOGOX	4			X4 VALUE	0.5
YOGOY	1			Y1 VALUE	0.20
YOGOY	2			Y2 VALUE	0.10
YOGOY	3			Y3 VALUE	0.05
YOGOY	4			Y4 VALUE	0.01
SAVAD					0
SAVN					5
SAVO					3
PSATIS					1.0
AVCRO					1.0
WPCI					0.7
AVCRX	1			X1 VALUE	0.50
AVCRX	2			X2 VALUE	0.75
AVCRX	3			X3 VALUE	0.9
AVCRY	1			Y1 VALUE	0.0
AVCRY	2			Y2 VALUE	0.5
AVCRY	3			Y3 VALUE	1.0





## APPENDIX B

ALPINE AREAS WORKSHOP

May 13 - 17, 1974

LIST OF PARTICIPANTS

Scientists

Austria

Dr. Walter Moser  
c/o Alpine Forschungsstelle Obergurgl  
der Universitaet Innsbruck  
Universitaetsstrasse 4/2  
A-6020 Innsbruck

Co-Chairman

Dr. Alexander Cernusca  
Institut fuer Allgemeine Botanik  
der Universitaet Innsbruck  
Sternwartestrasse 15  
A-6020 Innsbruck

Prof. Kurt Ehrendorfer  
Rechenzentrum der Hochschule  
fuer Bodenkultur  
W. Exner Haus  
Peter Jordanstrasse 82  
A-1190 Wien

Prof. Dr. H. Janetschek  
Zoologisches Institut  
Universitaetsstrasse 4  
A-6020 Innsbruck

Gerhard Margreiter  
Fuerstenweg 11  
A-6020 Innsbruck

Prof. Dr. H. Reisingl  
Geobotanik  
Sternwartestrasse 15a  
A-6020 Innsbruck

Mr. Schinner  
Institut fuer Mikrobiologie  
Sternwartestrasse 15  
A-6020 Innsbruck

ALPINE AREAS WORKSHOP — List of Participants

Canada

Dr. Carl J. Walters  
Institute of Animal Resource Ecology  
University of British Columbia  
Vancouver 8, B. C.  
Canada

Co-Chairman

Dr. Sandra Buckingham  
address as above

Mr. Ray Hilborn  
address as above

Dr. Fred Bunnell  
address as above

Dr. Pille Bunnell  
address as above

FRG

Prof. Dr. H. Heuberger  
Geographisches Institut der  
Universitaet Muenchen  
Luisenstrasse 37  
D-8 Muenchen

France

Prof. J. Giban  
C. N. R. S.  
Laboratoire des Petits Vertebres  
F-78350 Jouy-en-Josas

ALPINE AREAS WORKSHOP -- List of Participants

Italy

Prof. V. Giacomini  
Viale 21 Aprile, 93  
I-00162 Roma

Prof. S. Rinaldi  
Istituto di elettrotecnica  
ed elettronica  
Piazza Leonardo da Vinci, 32  
20133 Milano

Business

Adi Fender  
Hotelier  
A-6456 Obergurgl  
Austria

G. Scheiber  
Hotelier  
Hotel Gotthard  
A-6456 Obergurgl  
Austria

Government

Dr. Dipl. Ing. A. Partl  
Landesrat  
Landhaus  
A-6010 Innsbruck  
Austria

Dr. P. Scheiber  
Landhaus  
Abt. Sport  
A-6010 Innsbruck  
Austria

ALPINE AREAS WORKSHOP

May 13 - 17, 1974

LIST OF OBSERVERS

Dr. Walter  
Bundesministerium fuer Wissenschaft und Forschung  
Abt. Forschung  
Wahringerstrasse  
Wien  
Austria

Nationalrat  
Tirol  
Austria

LIST OF INVITEES WHO WERE UNABLE TO COME

Prof. Dr. Aulitzky  
Hochschule fuer Bodenkultur  
Gregor Mendelstrasse 35  
A-1190 Wien  
Austria

Prof. J. Balogh  
Institutum Zoosystematicum Universitatis  
Puskint utca 3  
Budapest VIII  
Hungary

Dr. Konrad Cihak  
Zentralanstalt fuer Meteorologie und Geodynamik  
Hohe Warte 38  
A-1190 Wien  
Austria

Prof. M. S. Ghilarov  
Laboratory of Soil Zoology  
Institute of Animal Morphology  
The Academy of Sciences  
Lenin Avenue 33  
Moscow W-71  
USSR

Prof. B. Messerli  
Geographisches Institut der Universitaet Bern  
Falkenplatz 18  
Ch-3012 Bern  
Switzerland

Alpine Areas Workshop - Observers and Invitees

Prof. D. Mlinsek  
Ul. Phorskega bataljona 157  
Y-61000 Ljubljana  
Yugoslavia

Prof. Dr. M. Moser  
Institut fuer Mikrobiologie  
Sternwartestrasse 15  
A-6020 Innsbruck  
Austria

Prof. P. Seibert  
Waldbauinstitut  
Abteilung Landschaftspflege und Vegetationskunde  
Schellingstrasse 12  
D-8000 Muenchen 40  
FRG

Prof. Dr. W. Tranquillini  
Bundesforstliche Versuchsanstalt Hofburg  
Rennweg 1  
A-6020 Innsbruck  
Austria

AGENDA

Alpine Areas Workshop

Schloss Laxenburg  
13 - 17 May 1974

Monday, 13 May 1974

- 8:50 Shuttle buses leave Park Hotel for Schloss Laxenburg.
- 9:15 Registration.  
Please have Questionnaire and Departure Note ready.
- 9:30 - 12:30 Workshop begins
- (a) Welcome and introduction.  
Dr. C. S. Holling  
Director of the IIASA Ecology Project
- (b) Slide show on mathematical modelling.  
Dr. Pille Bunnell  
University of British Columbia, Canada
- (there will be a mid-morning coffee break)
- (c) Lecture on the modelling process.  
Dr. Carl Walters  
University of British Columbia, Canada
- (d) Introduction to the focus of this workshop, the problem of the MAB Project Obergurgl.  
Dr. Walter Moser  
University of Innsbruck
- 12:30 - 14:00 Lunch. (Cost: AS 59 plus beverages)  
Gasthof Broschek, Biedermannsdorf
- 14:00 - 17:45 Workshop resumes
- (a) Definition of major components of Obergurgl problem.  
Dr. Moser
- (b) Interaction between system components.  
Dr. Walters
- (there will be a mid-afternoon coffee break)
- (c) Identification of variables for simulation.
- (d) Identification of desired policy options.
- (e) Assignment of submodel responsibilities.
- 17:45 Informal gathering.  
Wine will be served. A tour of IIASA facilities is included.
- 18:15 Shuttle buses leave from Schlossplatz for Park Hotel.

Alpine Areas Workshop - Agenda

Tuesday, 14 May 1974

- 9:00 Shuttle buses leave Park Hotel.
- 9:30 - 12:30 (a) Participants will work in small groups with a resource scientist/programmer to develop submodels for the major components of the Obergurgl system, using as a basis the variable list developed on Monday afternoon. The submodelling sessions will be interspersed with short meetings of the overall group, in order to clarify definitions and responsibilities as the submodels emerge.
- (b) Unless major problems arise on Monday, the following subgroups will be used:
- (1) Land use allocation - spatial distribution of land use and development, tourist facilities capacity.
- (2) Tourism demand - potential and realized number of tourists; perception of environmental quality.
- (3) Population and employment - local population size and structure, employment patterns, investment in tourist development.
- (4) Grazing and forests - agricultural development and reforestation, long term vegetation patterns.
- (5) Vegetation and soil dynamics - detailed analysis of pasture ecosystem to provide parameter values for subgroup (4).
- (coffee will be available during the day in the corridor)
- 12:30 - 14:00 Lunch. (Cost: AS 80 plus beverages)  
Gasthaus Hummer, Wiener Neudorf
- 14:00 - 18:15 Same as morning.
- 18:15 Shuttle buses leave from Schlossplatz.
- 19:15 An evening at a Heuriger.  
You are cordially invited to be the guest of the Ecology Project of IIASA at a Heuriger. Dinner will be served as well as the Heuriger wine. Shuttle buses will leave the Park Hotel at 19:15. Return to the hotel will be about 22:00.

Wednesday, 15 May 1974

- 9:00 Shuttle buses leave Park Hotel.
- 9:30 - 12:30 Same as Tuesday's agenda.
- (coffee available all day)



Alpine Areas Workshop - Agenda

Wednesday, 15 May 1974 - continued

- 12:30 - 14:00           Lunch. (Cost: AS 65 plus beverages)  
Gasthaus Hummer, Wiener Neudorf
- 14:00 - 17:45           (a) Same as Tuesday's agenda.  
  
                         (b) It is expected that working computer submodels will  
                         be developed by Wednesday evening.
- 17:45                   Informal gathering.  
Wine will be served.
- 18:15                   Shuttle buses leave from Schlossplatz.

Thursday, 16 May 1974

- 9:00                   Shuttle buses leave Park Hotel.
- 9:30 - 12:30           (a) Participants: Development of alternative management  
                         policies for testing with the model, under the  
                         direction of Dr. Moser.  
  
(coffee available      (b) IIASA programmers: Interfacing of submodels into  
all day)               overall model of the Obergurgl system, under the  
                         direction of Dr. Walters.
- 12:30 - 14:00           Lunch. (AS 76 plus beverages)  
Gasthaus Hummer, Wiener Neudorf
- 14:00 - 18:00           Same as morning.
- 18:30                   Cocktail party in Schloss Laxenburg.  
You are cordially invited to be the guest of the Ecology  
Project. Return to the Park Hotel will be about 20:00.  
Shuttle buses will leave from the Schlossplatz.

Friday, 17 May 1974

- 9:00                   Shuttle buses leave Park Hotel.
- 9:30 - 12:30           Test runs of computer model with policies developed on  
(coffee available      Thursday, and additional computer simulations as suggested  
all day)               by results of initial runs.
- 12:30 - 14:00           Picnic in Schlosspark. (Weather permitting)  
You are cordially invited to be the guest of the Ecology  
Project. If it is raining, we will proceed to Gasthaus  
Hummer.

Alpine Areas Workshop - Agenda

Friday, 17 May 1974 - continued

- 14:00 - 17:00           (a) Summary of model predictions.  
                         (b) Discussion of implications for data collection  
                          and management.  
                         (c) Development of initial plans for future workshops  
                          on other alpine areas.
- 17:00                   Beer party.  
                         You are cordially invited to join the IIASA staff as  
                         the guest of the Ecology Project.
- 18:15                   Shuttle buses leave Schlossplatz.