

NOT FOR QUOTATION  
WITHOUT PERMISSION  
OF THE AUTHOR

DRAWING AND UNDERSTANDING  
SYSTEMS STRUCTURES:  
AN INTRODUCTION TO THE  
SKETCH SYSTEM

Kozo Sugiyama

October 1982  
WP-82-97

*Working Papers* are interim reports on work of the International Institute for Applied Systems Analysis and have received only limited review. Views or opinions expressed herein do not necessarily represent those of the Institute or of its National Member Organizations.

INTERNATIONAL INSTITUTE FOR APPLIED SYSTEMS ANALYSIS  
A-2361 Laxenburg, Austria

## PREFACE

If we adhere to Einstein's dictum that "imagination is more important than knowledge," then in the course of research, methods for enhancing our imagination may be more important than methods that only generate or "encapsulate" knowledge.

With the advent of computers possessing strong graphic capabilities, methods for enhancing or simply using the natural human gift of imagination have become popular (for example in computer-aided design).

This working paper is a concise description of work done by Dr. Kozo Sugiyama and his collaborators at the International Institute of Advanced Studies of Systems Information Sciences of the Fujitsu Corporation in Japan and work performed during Dr. Sugiyama's stay at IIASA. It is concerned with the important problem of structural analysis of complex systems. The method labeled Visual-Q-Analysis helps to reveal some features of structure by "hierarchizing" it and thereby preparing it for visual exposure and analysis.

This method has been applied to the analysis of important innovations of the future (e.g., the fifth generation of computers) as documented in other working papers by the author.

The attempt to apply these methods to an I/O analysis of an economy shows that Visual-Q-Analysis is a promising method for innovation management research.

Tibor Vasko

Task Leader

Innovation Management Task

FOREWORD

SKETCH system is a handy-typed machine drawing system of a finite labeled directed graph. A proto-type of SKETCH system (algorithms and programs) was developed and applied to various problems by the present author and his colleagues<sup>\*)</sup> at the International Institute for Advanced Study of Social Information Science, Fujitsu Limited, Japan. In order to utilize for the Innovation Management Task of IIASA, this system has been installed on FORTRAN-77/UNIX-7/VAX780 by the present author, where specifications for input/output have been modified to fit the new environment, to improve the easiness of operations and to advance the effectiveness of representations. Moreover, several applications ranging from simple examples to practical problems have been carried out by using the new system.

This paper is brief but overall introduction to SKETCH system. Our viewpoint, algorithms, design(specification) and applications are shown to demonstrate the usefulness of SKETCH system for scientists and engineers.

\*) Dr. Mitsuhiko Toda

Dr. Shojiro Tagawa (currently Assistant Prof.  
of Chiba Univ.)

## ACKNOWLEDGEMENTS

The author would like to express the greatest thanks for the suggestions of Prof. Yoichi Kaya, the University of Tokyo, motivating the research for effective representations of structures of a national economy, the continuing guidance and encouragement of Dr. Tosio Kitagawa, Director of the International Institute for Advanced Study of Social Information Science, Fujitsu Ltd., and the helpful comments of Prof. Tibor Vasko, Deputy Area Chairman of the Management and Technology Area of the International Institute for Applied Systems Analysis.

CONTENTS

1.	Introduction	1
2.	How to approach the problem	5
2.1	Identification of readability elements	5
2.2	Specification of basic rules of drawing	8
2.3	Formulation as a multistage multiobjective problem	8
2.4	Theoretical and heuristic approaches	11
3.	Basic definitions	12
3.1	n-level hierarchy and map	12
3.2	Matrix realization of n-level hierarchies	13
3.3	The number of crossings of n-level hierarchies	13
3.4	Barycenters	15
3.5	Connectivity	16
4.	Brief description of algorithms	17
4.1	Resolution of cycles (Step I)	17
4.2	Level assignment of a acyclic digraph (Step II)	18
4.3	Conversion into a proper hierarchy (Step III)	18
4.4	Reduction of the number of crossings (Step IV)	19
4.5	Determination of horizontal positions of vertices (Step V)	21
5.	How to use SKETCH system	25
A.	Data for the layout of a hierarchy	25
B.	Data for vertices	26
C.	Data for edges	28
D.	Data for specifying levels of vertices	28
6.	Applications	30
6.1	Predator-prey ecosystem	30
6.2	Call structure in a FORTRAN program	32
6.3	SD(System Dynamics) diagrams	32
6.4	Research trends observed in citations among literatures	35
6.5	Earthquake disaster relational model	36
6.6	Visual representation of national economy (I/O table)	41
6.7	Visual Q-analysis	47
	Appendix : Bibliography of SKETCH system	48
	References	52

## 1. Introduction

In social sciences, natural sciences and engineering, we can find the widespread use of structural concepts and diagrammatical representations of them, i.e., scientists and engineers frequently utilize block diagrams, flowcharts etc. to express ideas, views, procedures, model structures, relationships among system elements, results of analyses etc. in every phase of research activities such as analysis, synthesis, building mental models, discussion, presentation and documentation. These facts show that the diagrammatical representations are widely recognized as a convenient medium to communicate structural information among researchers and audiences. This is because

(i) the sense of sight is quick in searching and understanding, and both analytical and synthetic,

(ii) no special visual literacy is required to "read" diagrams. Consequently we can grasp the holistic image of structures readily at a glance, if, of course, they are drawn in a visually understandable ("readable" or "legible") way. However, it is troublesome to draw a lot of diagrams effectively even when they are not complicated; moreover it is extremely difficult to draw confused diagrams manually. Therefore a handy-typed drawing system by machine is desirable. Such the system is of great assistance not only to representations but also an efficient analysis of complex problems where the readable maps can be utilized as a graphical language for interactive use of a computer.

Although a variety of empirical structures is almost endless, we can employ directed graphs as the abstract notion of the structures, where vertices and edges of the graphs correspond to

empirical entities and relationships among them, respectively.

SKETCH system has been developed to draw, by machine, a finite, labeled and directed graph (or digraph)  $G$  which is expressed by

$$G = ( V, E, f_V, f_E, L_V, L_E ) \quad (1-1)$$

where  $V$  : vertex set

$E$  : edge set

$L_V$  : set of possible interpretations (labels) of vertices

$L_E$  : set of possible interpretations (labels) of edges

$f_V : V \rightarrow L_V$

$f_E : E \rightarrow L_E$ .

By SKETCH system we can obtain (two dimensional) diagrams of the graphs in a visually understandable form (we call them "readable maps" for simplicity) on a graphic display and/or a XY-plotter only by simple operations; Fig.1 shows an example where

- (i) we are not required to know the numbers of vertices and edges, and the numbers of characters and lines of the labels,
- (ii) we are also not required to give input data assigning arrangements of vertices and routings of edges to the system,
- (iii) we can easily specify shapes of vertices and kinds and orientations of edges (lines) by input parameters.

Algorithms for SKETCH system were developed and implemented on FORTRAN-H/OS-IV/FACOM M190, and many applications were carried out by the present author and his colleagues at the International Institute for Advanced Study of Social Information Science, Fujitsu Limited, Japan. These results have already been presented and published elsewhere; most of them are listed in Appendix. The present author has installed SKETCH system on FORTRAN-77/UNIX-7/



```
0 0 4 0 1 0.7
a1p1: identification of\ readability elements\ (objectives)
222 p2: specification of\ basic rules of drawing\ (constraints)
xyz1p3: formulation as a multi-stage\ multi-objective problem
p5 p4: theoretical and\ heuristic approaches
//
a 222 13
222 xyz
xyz p5
```

(a)

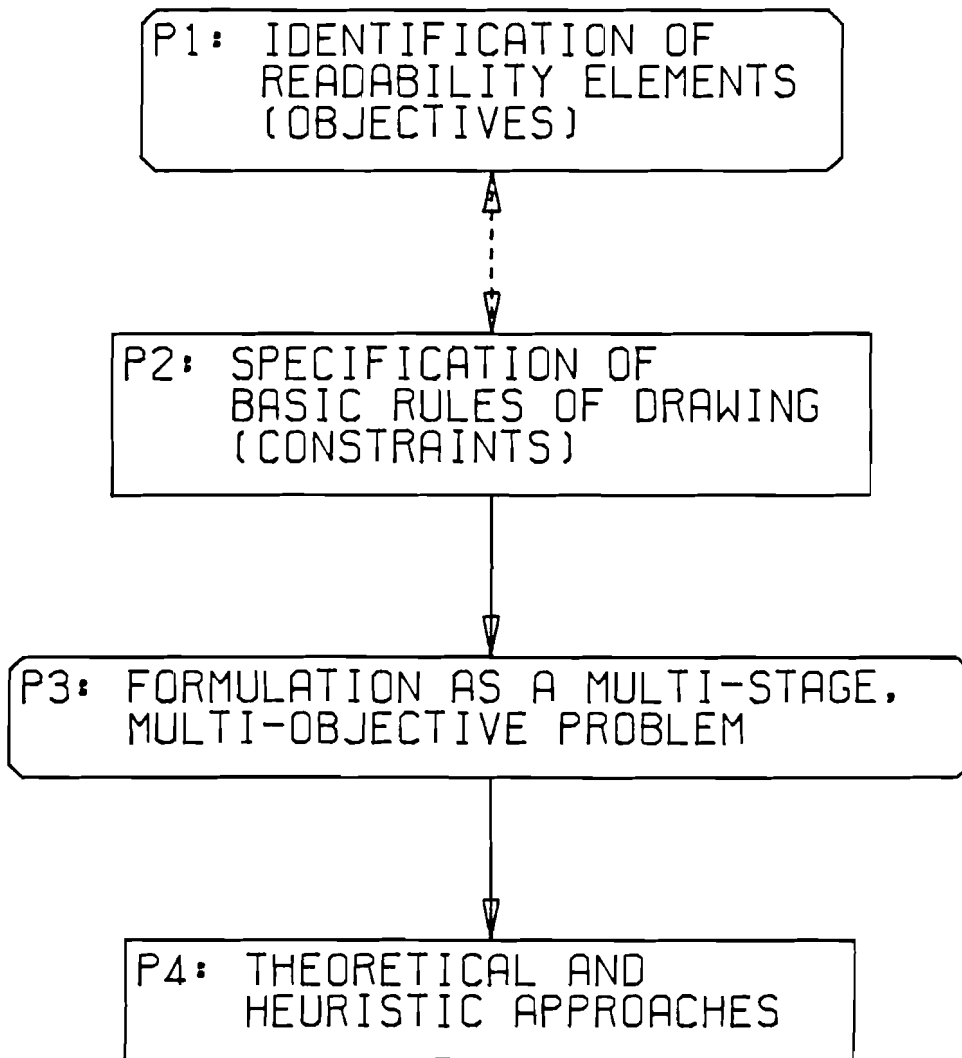

(b)

Fig.1 Procedures to approach the problem.

(a) input file (b) output(drawing)

VAX780, IIASA where input/output modules have been modified to fit to the new environment, and the easiness of operations and the effectiveness of representations have been considerably improved\*.) Further, several applications ranging from simple examples to practical problems have been carried out with the use of SKETCH system.

This paper is intended to introduce all aspects of SKETCH system briefly. First, we represent how to approach the problem of generating a readable map, where discussions on readability in drawings of graphs and rules of drawing are important. Second, after some preparations, the heuristic algorithm used in SKETCH system is introduced by using examples although we developed both theoretical and heuristic algorithms. Third, the use of the system is explained by describing the specifications of input/output. Finally, in showing several applications we demonstrate the usefulness of SKETCH system for various fields and purposes.

In the sections in which descriptions are based mainly upon the previous work listed in Appendix, reference numbers are shown by [ ] following the headings of such sections.

---

\*) In the implementation of SKETCH system on VAX11/780 we utilize the graphic subroutine package prepared by Bernhard Schweeger, Computer Services, IIASA.

## 2. How to Approach the Problem [12,13]

We analyse, formulate, and solve the problem of generating a readable map of a digraph by the procedures illustrated in Fig.1.

### 2.1 Identification of readability elements

To begin, we should consider "readability" in the visualization (two-dimensional drawing) of a digraph, and identify elements of the readability. Strictly speaking, the readability may depend upon problems studied and, more intrinsically, upon the audiences of a map. The purpose of this analysis, however, is to consider common aspects of the readability. This is because the constitution of a digraph is extremely simplified and therefore it seems that the ambiguity in identifying the readability elements is sufficiently low. We consider that in general it is difficult to grasp the structure of a digraph readily,

- A) unless vertices are laid out in some regular form (e.g. clustered layout, layout on a lattice, layout on circles), and
- B) unless edges are drawn in such a form that paths can be readily traced by human eyes.

Since a digraph contains a hierarchical structure inherently within itself, it seems to be most natural and convenient to layout vertices in a hierarchical form, where of course we should resolve cycles by some appropriate method such as condensation, finding feedback edge sets etc. Consequently the former condition A) is replaced by the following readability element.

element a : "Hierarchical" layout of vertices.

Here it is important to point out that the former condition A) can be further applied to vertices on a level in the hierarchical layout, i.e. vertices can be clustered on each level if necessary.

The latter condition B) is broken down into the following four readability elements. The greatest difficulty in tracing paths is line-crossings and therefore we have

element b : "Less-crossings" of lines(edges).

Since it is easy to trace straight lines, we have

element c : "Straightness" of lines.

This element is further broken down into "straightness" of one-span edges(element  $c_1$ ) and "straightness" of long span edges (element  $c_2$ ). In tracing paths, it is desirable that paths are short. So, we have

element d : "Close" layout of vertices connected to each other.

Finally it is also desirable that the structural information on branching and joining of paths is drawn clearly. This is expressed by

element e : "Balanced" layout of lines coming into or going from a vertex.

This element can be explained by the following example, where drawings are more desirable in the order of (a) < (b) < (c).



(a)

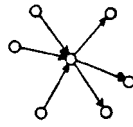

(b)

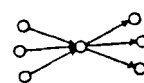

(c)

The above five readability elements are different in importance. In this paper elements a and b are considered to be more important than the other elements. Moreover the elements are not independent; i.e. some elements are cooperative and some are competing, which are shown by several examples.

(i) The dependence between element b and element d is suggested by the following example:

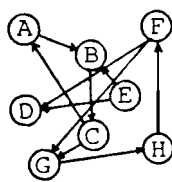

(a)

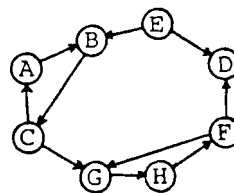

(b)

where the drawing (b) is obtained from the drawing (a) by reducing the number of crossings. As the result we can see that the vertices connected to each other are laid out closely.

(ii) The trade-off relation between element b and element c is known from the following example:

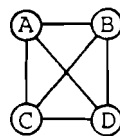

(a)

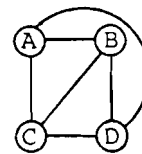

(b)

where it is found that we can not attain both no-crossings (the drawing (b)) and the straightness of lines (the drawing (a)) simultaneously.

(iii) The following example shows the complicated competition among element a, element b and element c:

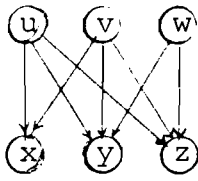

(a)

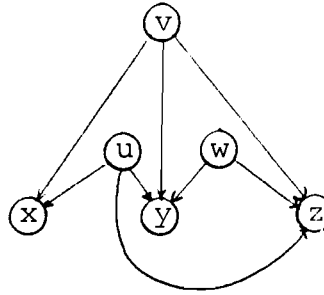

(b)

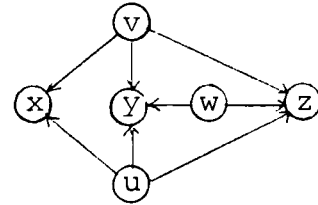

(c)

where elements a and c are attained in the drawing (a), elements a and b in the drawing (b), and elements b and c in the drawing (c).

## 2.2 Specification of basic rules of drawing

Basic rules to draw a hierarchy are specified. In order to draw a hierarchy, we should determine a layout of vertices and how to draw edges. We specify the basic rules regarding these two aspects as follows.

Rule  $\alpha$ ) Vertices are placed on horizontal lines in each level of the hierarchy without overlapping.

Rule  $\beta$ ) Each edge is drawn with a straight line.

The problem is simplified by the specification of the basic rules for drawing. We have only to determine horizontal positions of vertices which attain readability. It should be noted that Rule  $\alpha$ ) and Rule  $\beta$ ) correspond to element a and element c<sub>1</sub>, respectively.

## 2.3 Formulation of the problem to generate readable maps

The problem to generate readable maps is formulated as a multistage multiobjective problem. Procedures in the whole algo-

rithm developed are shown in Fig. 2. The algorithm is constituted from six steps as follows.

Step I (step for resolving cycles) : If a given digraph (or a given set of directed pairwise relations among elements of a system) is cyclic, then the digraph is transformed into a acyclic digraph as a formalization. How to resolve cycles depends upon the researcher's view and the problem studied.

Step II (step for the hierarchization) : We get a hierarchy by assigning a level of each vertex in the obtained acyclic digraph, where element  $\underline{a}$  is attained.

Step III (step for getting a "proper" hierarchy) : If the hierarchy has long span edges, it is converted into a proper hierarchy by adding dummy vertices and edges.

Step IV (step for reducing the number of crossings) : The number of crossings depends only upon orders of vertices in each level. In order to attain element  $\underline{b}$  the number of crossings of edges in the proper hierarchy is reduced by permuting orders of vertices in each level.

Step V (step for determining positions of vertices) : Horizontal positions of vertices are determined by considering three elements  $\underline{c}_2$ ,  $\underline{d}$  and  $\underline{e}$ , where the order of the vertices determined in Step IV is given as constraints to preserve the reduced number of crossings. Each vertex is treated as a square to draw the label of the vertex.

Step VI (step for drawing) : A (two-dimensional) picture of the hierarchy is drawn by machines, where the dummy

0 0 3 4 1 0  
1 directed graph  
2 <are there strongly\connected components?>  
3 [no]  
4 [yes]  
5 condensation  
6 formal dissolutions\of feedback loops  
7 hierarchization  
8 hierarchy  
9 transitive\reduction  
10 adding dummy\nodes  
11 proper\hierarchy  
12 reduction of the\number of crossings  
13 determination of\npositions of vertices  
14 drawing  
15 diagrams of directed graph

```
//  
1 2  
2 3 11  
2 4 11  
3 7  
4 5  
4 6  
5 7  
6 7  
7 8  
8 9  
8 10  
9 10  
10 11  
11 12  
12 13  
13 14  
14 15
```

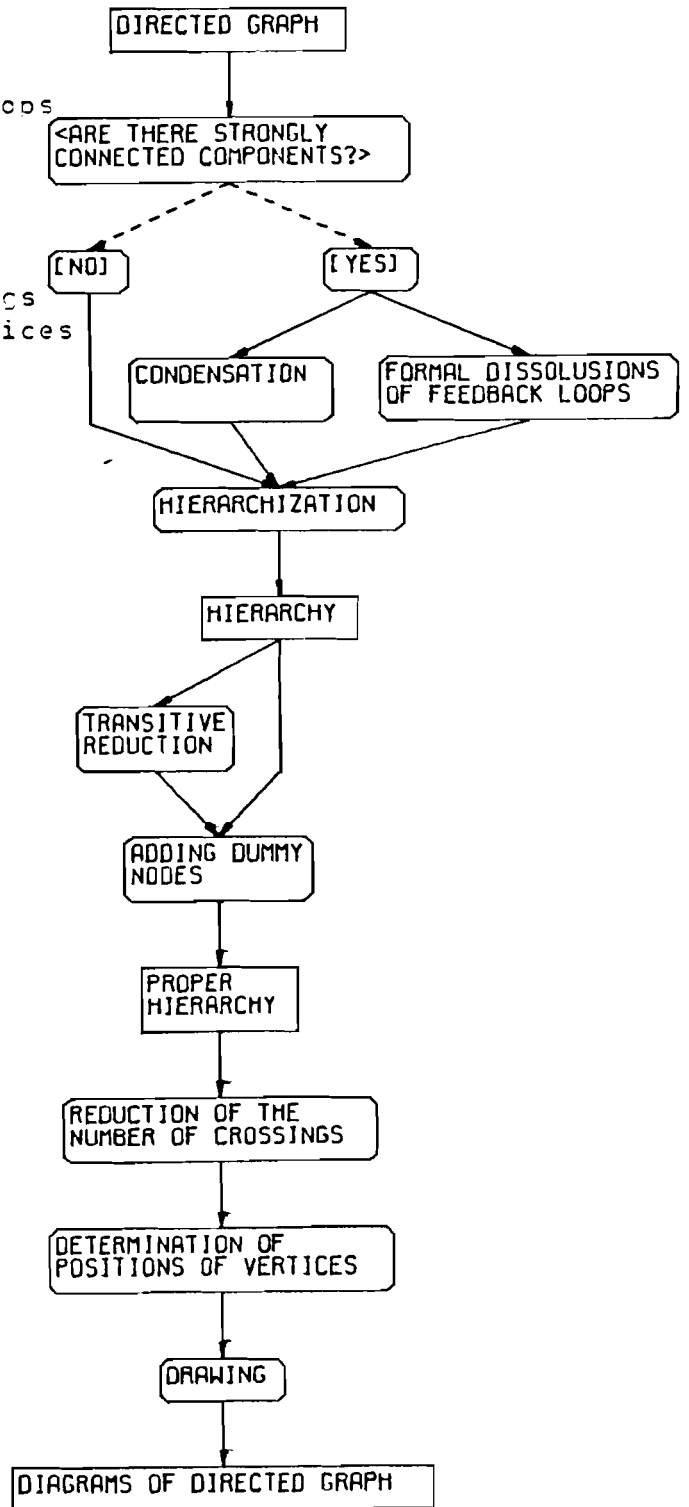

Fig.2 Flow diagrams of procedures in the whole algorithm.



vertices and edges are deleted, the corresponding long span edges are regenerated, and the feedback edges determined in Step I are expressed by the arrow with the opposite direction.

In the above, Steps IV and V are main steps for the whole algorithm.

#### 2.4 Theoretical and heuristic approach

Both theoretical and heuristic approaches in developing algorithms are carried out, since the theoretical methods are useful in recognizing the nature of the problem, and the heuristic methods make it possible to enlarge the size of hierarchies with which we can deal. We developed the algorithms for Step IV and Step V as follows:

	Step IV	Step V
theoretical :	Penalty Minimization (PM) method [12,19,22]	Barycentric (BC) method
heuristic :	Quadratic Programming (QP) method [6,12,13]	Priority (PR) method

Since the crossing problem is combinatorial in nature, the minimum solutions require extensive use of computing time. Therefore we have developed a heuristic algorithm called BC method. Its usefulness is justified by testing the performance of the algorithm. The problem to determine the horizontal positions of the vertices which attain elements  $\underline{c}_2$ ,  $\underline{d}$  and  $\underline{e}$  is formulated as a quadratic programming. The heuristic layout algorithm is called PR method where the computing cost is significantly less than the QP method. BC and PR methods are employed in SKETCH system and so we introduce only these heuristic methods in this paper.

### 3. Basic Definitions [12]

#### 3.1 n-level hierarchy and map

An n-level hierarchy ( $n \geq 2$ ) is defined as a directed graph  $(V, E)$ , where  $V$  is called a set of vertices and  $E$  a set of edges, which satisfies the following conditions.

1)  $V$  is partitioned into  $n$  subsets, that is

$$V = V_1 \cup V_2 \cup \dots \cup V_n \quad (V_i \cap V_j = \phi, i \neq j)$$

where  $V_i$  is called the  $i$ th level and  $n$  the length of the hierarchy.

2) Every edge  $e = (v_i, v_j) \in E$ , where  $v_i \in V_i$  and  $v_j \in V_j$ , satisfies  $i < j$ , and each edge in  $E$  is unique.

The n-level hierarchy is denoted by  $G = (V, E, n)$ .

An n-level hierarchy is called "proper" when it satisfies further the following conditions.

3)  $E$  is partitioned into  $n-1$  subsets, that is

$$E = E_1 \cup E_2 \cup \dots \cup E_{n-1} \quad (E_i \cap E_j = \phi, i \neq j),$$

where  $E_i \subset V_i \times V_{i+1}$ ,  $i = 1, \dots, n-1$ .

4) An order  $\sigma_i$  of  $V_i$  is given for each  $i$ , where the term "order" means a sequence of all vertices of  $V_i$ ,  $\sigma_i = v_1 v_2 \dots v_{|V_i|}$  ( $|V_i|$  denotes the number of vertices of  $V_i$ ). The n-level hierarchy is denoted by  $G = (V, E, n, \sigma)$ , where  $\sigma = (\sigma_1, \dots, \sigma_n)$ .

The drawing of a hierarchy is called a map. In a map all the vertices belonging to the  $i$ th level  $V_i$  are arranged on the  $i$ th line of the  $n$  horizontal real lines which are numbered from the top to the bottom (Rule  $\alpha$ ). The coordinate  $x(v_i)$  of vertex  $v_i$  on a real line is called a horizontal position. Every edge is drawn with a straight line (Rule  $\beta$ ).

By specifying the rules of drawing, the problem is significantly simplified since the number of crossings of a proper hierarchy is determined by orders  $\sigma$  of vertices in each level and vertical coordinates of vertices are fixed according to the level where each vertex is included. In the subsequent sections, discussions are restricted to proper hierarchies. Accordingly, a proper hierarchy is called a hierarchy for simplicity.

### 3.2 Matrix realization of n-level hierarchies

For an n-level hierarchy  $G=(V,E,n,\sigma)$ , the matrix realization of G is defined as follows.

1) A matrix  $M^{(i)}=M(\sigma_i,\sigma_{i+1})$  is a  $|V_i| \times |V_{i+1}|$  matrix whose rows and columns are ordered according to  $\sigma_i$  and  $\sigma_{i+1}$ , respectively.

2) Let  $\sigma_i=v_1 \dots v_k \dots v_{|V_i|}$  and  $\sigma_{i+1}=w_1 \dots w_l \dots w_{|V_{i+1}|}$ . Then the  $(v_k, w_l)$  element of  $M^{(i)}$ , denoted by  $m_{kl}^{(i)}$ , is given by

$$m_{kl}^{(i)} = \begin{cases} 1 & \text{if } (v_k, w_l) \in E_i \\ 0 & \text{otherwise} \end{cases} \quad (3-1)$$

where  $M^{(i)}$  is called an interconnection matrix.

3) A matrix realization g of G is given by the formula

$$g(\sigma_1, \dots, \sigma_n) = M^{(1)} \dots M^{(n-1)} \quad (=g(V,E,n,\sigma)) \quad (3-2)$$

An example of a hierarchy and its matrix realization is shown in Fig.3.

### 3.3 The number of crossings of n-level hierarchies

Formulas to calculate the number of crossings on the map of n-level hierarchies have been given by Warfield(1977). In the

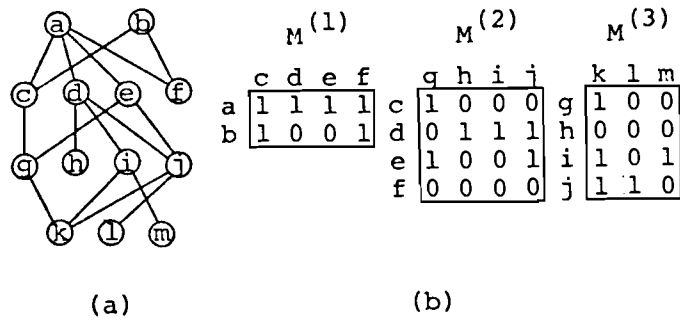

Fig.3 (a) Four-level hierarchy  
(b) Its matrix realization.

$i$ th interconnection matrix  $M^{(i)} = M(\sigma_i, \sigma_{i+1})$  of  $g$ , let  $\sigma_i = v_1 \dots v_j \dots v_k \dots v_{|V_i|}$ . Further, let the row vector of  $M^{(i)}$  corresponding to a vertex  $v \in V_i$  be denoted by  $r(v)$ , then the number of crossings  $k(r(v_j), r(v_k))$ ,  $r(v_k)$  produced by the ordered pair of row vectors  $(r(v_j), r(v_k))$  is given by the formula

$$k(r(v_j), r(v_k)) = \sum_{\alpha=1}^{q-1} \sum_{\beta=\alpha+1}^q m_{j\beta}^{(i)} m_{k\alpha}^{(i)} \quad (3-3)$$

where  $q = |V_{i+1}|$ . Consequently the formula

$$\begin{aligned} K(M^{(i)}) &= \sum_{j=1}^{p-1} \sum_{k=j+1}^p k(r(v_j), r(v_k)) \\ &= \sum_{j=1}^{p-1} \sum_{k=j+1}^p \left( \sum_{\alpha=1}^{q-1} \sum_{\beta=\alpha+1}^q m_{j\beta}^{(i)} m_{k\alpha}^{(i)} \right) \end{aligned} \quad (3-4)$$

gives the number of crossings of  $M^{(i)}$  where  $p = |V_i|$ . Similar expressions can be obtained starting from ordered pairs of column vectors. From (3-4), the total number  $K(g)$  of crossings of  $g$  is given by

$$K(g) = K(M^{(1)}) + \dots + K(M^{(n-1)}). \quad (3-5)$$

### 3.4 Barycenters

Here two expressions of barycenters are defined. First the formulas

$$B_{ik}^R = \sum_{l=1}^q l \cdot m_{kl}^{(i)} / \sum_{l=1}^q m_{kl}^{(i)}, \quad k = 1, \dots, p \quad (=|V_i|) \quad (3-6)$$

$$B_{il}^C = \sum_{k=1}^p k \cdot m_{kl}^{(i)} / \sum_{k=1}^p m_{kl}^{(i)}, \quad l = 1, \dots, q \quad (=|V_{i+1}|) \quad (3-7)$$

give row and column barycenters of a binary interconnection matrix  $M^{(i)} = (m_{kl}^{(i)})$  respectively, which will be used in BC method. Second upper and lower barycenters  $B_{ik}^U, B_{ik}^L$  of upper and lower vertices connected to the  $k$ th vertex  $v_k^i$  in the  $i$ th level are defined by

$$B_{ik}^U = \sum_{j=1}^p x(v_j^{i-1}) m_{jk}^{(i-1)} / C_{ik}^U, \quad k = 1, \dots, |V_i| \quad (3-8)$$

$$B_{ik}^L = \sum_{l=1}^q x(v_l^{i+1}) m_{kl}^{(i)} / C_{ik}^L, \quad k = 1, \dots, |V_i| \quad (3-9)$$

where  $p=|V_{i-1}|$  and  $q=|V_{i+1}|$ , and  $x(v)$  is the horizontal position of a vertex  $v$ . These barycenters will be used in the PR method.

### 3.5 Connectivity

In an  $n$ -level hierarchy  $G=(V,E,n,\sigma)$  if  $\sigma_i = v_1^i \dots v_k^i \dots v_{|V_j|}^i$ ,  $i=1, \dots, n$ . then the upper connectivity  $C_{ik}^U$  of vertex  $v_k^i$  and the lower connectivity  $C_{ik}^L$  of vertex  $v_k^i$  are defined by the formulas

$$C_{ik}^U = \sum_{j=1}^{|\mathcal{V}_{i-1}|} m_{jk}^{(j-1)}, \quad k=1, \dots, |\mathcal{V}_j|, \quad i=2, \dots, n \quad (3-10)$$

$$C_{ik}^L = \sum_{l=1}^{|\mathcal{V}_{i+1}|} m_{jk}^{(i)}, \quad k=1, \dots, |\mathcal{V}_i|, \quad i=1, \dots, n-1. \quad (3-11)$$

#### 4. Brief Description of Algorithms [8,11,12,23,18,24,27]

##### 4.1 Resolution of cycles (Step I)

A way of resolving cycles should be chosen by the user of SKETCH system according to his problem and his purpose. We can indicate the following variations as the way of resolving cycles.

###### (1) Condensation

Each set of strongly connected vertices is replaced by a representative vertex and edges among the vertices are removed. This way can be seen in ISM(interpretive structural modeling) etc. and is effective when a mathematical equivalence among vertices correspond to an equivalence in empirical meanings of the vertices. The algorithm for condensation is found in Warfield(1974).

###### (2) Formal (or pseudo) resolution

In order to resolve cycles, the directions of a part of edges are reversed. However, in drawing the original directions are used. Therefore this way of resolution is called "formal" or "pseudo". There are many methods for this purpose. One of them is well-known Minimum Feedback Arc Set problem, of which algorithm is seen in Lempel et al.(1966). Another method is shown in Applications(Section 6.6).

###### (3) Double layout

In order to resolve cycles, a part of vertices constituting cycles is laid out doubly in the top level and the bottom level of a hierarchy. This is a two-dimensional projection of the recurrent hierarchy which is defined in [12]. An application of this method is shown in Applications(Section 6.3).

#### 4.2 Level assignment of a acyclic digraph (Step II)

A level assignment in a digraph  $G=(V,E)$  is defined as  $\psi : v \rightarrow \{1,2,3,\dots\}$  which satisfies 1)  $\{v | v \in V, \psi(v)=1\} \neq \phi$ , 2)  $\psi(v) < \psi(w)$  for each  $e=(v,w) \in E$ . We can indicate the following variations as the way of level assignment.

##### (1) Minimizing the number of levels

The number of levels is minimized. In this case the number of levels is equal to the number of vertices contained by the longest path in  $G$ . In ISM this type of level assignment is adopted (Warfield 1974).

##### (2) Tightly connected hierarchy

When any two vertices in a hierarchy  $G=(V,E,n)$  are connected by a path which is formed only by 1-span edges, we say that the hierarchy is tightly connected. The algorithm to obtain a tightly connected hierarchy from a connected acyclic digraph is shown in [11].

##### (3) Level assignment with constraints for the numbers of vertices in each level

This is formulated as the problem to be equivalent to PERT problem with resource constraints (Elmaghraby 1977).

##### (4) Level assignment when each edge is weighted

This algorithm is found in [24,27].

#### 4.3 Conversion into a proper hierarchy (Step III) [18]

An  $n$ -level hierarchy  $G(V,E,n)$  is given. If  $j-i \geq 2$  for any edge  $e=(v_i, v_j)$ ,  $v_i \in V_i$ ,  $v_j \in V_j$ , then add dummy vertices  $w_{i+1}, \dots, w_{j-1}$  to  $V_{i+1}, \dots, V_{j-1}$ , respectively, and replace the edge  $(v_i, v_j)$  with edges  $(v_i, w_{i+1}), (w_{i+1}, w_{i+2}), \dots, (w_{j-1}, v_j)$ . If  $j-i=1$ , do nothing.



#### 4.4 Reduction of the number of crossings (Step IV)

Let  $S_i$  be a set of all possible orders  $\sigma_i$  in an n-level hierarchy  $G=(V,E,n,\sigma)$  and  $S=S_1 \times \dots \times S_n$ , then the problem minimizing the number of crossings of the n-level hierarchy is stated by

$$\text{minimize } \{K(g(\sigma)) \mid \sigma \in S\} \quad (4-1)$$

according to formulas (3-2), ..., (3-5). This problem, however, is combinatorial in nature, therefore, it is difficult to obtain the optimum solution when the size of the problem is not small.

Here we show briefly a heuristic algorithm called Barycentric (BC) method by using examples for two level hierarchies and for n-level hierarchies. In this method rows and columns of matrix(matrix realization of two-level hierarchy) are reordered according to the increasing order of barycenters. (This operation is called "barycentric ordering".) Complete descriptions of both theoretical and heuristic algorithms can be seen in [12].

##### A. Algorithm for two-level hierarchies

The algorithm consists of two phases, Phase 1 and Phase 2. Phase 2 uses Phase 1 as a subalgorithm. In Phase 1 the barycentric ordering of rows or columns is repeated in turn. In this operation for Phase 1, the orders of the rows(or columns) which have equal barycenters are preserved. However, we may be able to reduce the number of crossings by changing these orders. Therefore, Phase 2 is introduced to carry out the operation to reorder rows (or columns) with equal barycenters just after the execution of Phase 1. In Phase 2 the orders of these rows(or columns) are reversed in each set (this operation is called "reversion" of rows(or columns)), then Phase 1 is reexecuted starting with columns (or rows). (See Fig.4)

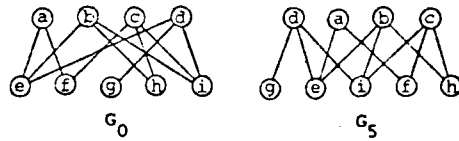

- (1)  $M_0$  is the initial interconnection matrix of  $G_0$ .  
 (2) By reordering rows b,c,d of  $M_0$ ,  $M_1$  is obtained.

$$M_0 = \begin{array}{c|cccc|c} & e & f & g & h & i \\ \hline a & 1 & 1 & 0 & 0 & 0 & 1.5 \\ b & 1 & 0 & 0 & 1 & 1 & 3.3 \\ c & 0 & 1 & 0 & 1 & 1 & 3.7 \\ d & 1 & 0 & 1 & 0 & 1 & 3 \\ \hline & 3.3 & 2.4 & 2.5 & 3 & & \end{array} \quad M_1 = \begin{array}{c|cccc|c} & e & f & g & h & i \\ \hline a & 1 & 1 & 0 & 0 & 0 & 1.5 \\ d & 1 & 0 & 1 & 0 & 1 & 3 \\ b & 1 & 0 & 0 & 1 & 1 & 3.3 \\ c & 0 & 1 & 0 & 1 & 1 & 3.7 \\ \hline & 2.25 & 2.35 & 3 & & & \end{array}$$

$K(M_0) = 14$                        $K(M_1) = 11$

- (3) By reordering columns f,g,h,i of  $M_1$ ,  $M_2$  is obtained. (End of Phase 1)  
 (4) By reversing the order of columns e,g of  $M_2$ ,  $M_3$  is obtained. (Start of Phase 2)

$$M_2 = \begin{array}{c|cc|cc|c} & e & g & f & i & h \\ \hline a & 1 & 0 & 1 & 0 & 0 & 2 \\ d & 1 & 1 & 0 & 1 & 0 & 2.3 \\ b & 1 & 0 & 0 & 1 & 1 & 3.3 \\ c & 0 & 0 & 1 & 1 & 1 & 4 \\ \hline & 2 & 2 & 2.5 & 3 & 3.5 & \end{array} \quad M_3 = \begin{array}{c|cc|cc|c} & g & e & f & i & h \\ \hline a & 0 & 1 & 1 & 0 & 0 & 2.5 \\ d & 1 & 1 & 0 & 1 & 0 & 2.3 \\ b & 0 & 1 & 0 & 1 & 1 & 3.3 \\ c & 0 & 0 & 1 & 1 & 1 & 4 \\ \hline & 2 & 2 & 2.5 & 3 & 3.5 & \end{array}$$

$K(M_2) = 9$                        $K(M_3) = 9$

- (5) By reordering rows a,d of  $M_3$ ,  $M_4$  is obtained.  
 (6) By reordering columns f,i of  $M_4$ ,  $M_5$  is obtained. (End of Phase 2)

$$M_4 = \begin{array}{c|cc|cc|c} & g & e & f & i & h \\ \hline d & 1 & 1 & 0 & 1 & 0 & 2.3 \\ a & 0 & 1 & 1 & 0 & 0 & 2.5 \\ b & 0 & 1 & 0 & 1 & 1 & 3.3 \\ c & 0 & 0 & 1 & 1 & 1 & 4 \\ \hline & 1 & 2 & 3 & 2.7 & 3.5 & \end{array} \quad M_5 = \begin{array}{c|cc|cc|c} & g & e & i & f & h \\ \hline d & 1 & 1 & 1 & 0 & 0 & 2 \\ a & 0 & 1 & 0 & 1 & 0 & 3 \\ b & 0 & 1 & 1 & 0 & 1 & 3.3 \\ c & 0 & 0 & 1 & 1 & 1 & 4 \\ \hline & 1 & 2.2 & 2.7 & 3 & 3.5 & \end{array}$$

$K(M_4) = 8$                        $K(M_5) = 7 = \min.$

Fig.4 An application of the 2-level BC method.

B. Algorithm for n-level hierarchies

The foregoing algorithms for 2-level hierarchy  $g(\sigma_1, \dots, \sigma_n) = M^{(1)} \dots M^{(n-1)}$  for  $n \geq 3$ . The n-level algorithm consists of two procedures, Phase 1 and Phase 2. Phase 1 consists of two procedures, Down and Up. In Down procedure, column orders of interconnection matrices of  $g(\sigma_1, \dots, \sigma_n)$  are permuted in the order of  $M^{(1)}, \dots, M^{(n-1)}$  according to the barycentric ordering. As a consequence, we have  $g(\sigma'_1, \dots, \sigma'_n) = M^{(1)'} \dots M^{(n-1)'}$ . In Up procedure, row orders of interconnection matrices of  $g(\sigma'_1, \dots, \sigma'_n)$  are permuted in the order of  $M^{(n-1)'}, \dots, M^{(1)'}$ . Thus Down and Up

procedures are repeated in turn. Phase 1 is terminated when at least one of the following conditions is attained:

- a) The same matrix appears periodically.
- b) The number of times of iteration reaches an initially given number.

When there exist sets of rows(or columns) which have equal barycenters just after the execution of Phase 1, Phase 2 is executed, where a procedure similar to Phase 2 of the 2-level algorithm is applied.

Phase 2 consists of two procedures, Down and Up. In Down (Up) procedure, the order of columns (rows) in level  $i$  with equal barycenters is reversed and Phase 1 starts with Down (Up) procedure, where  $i$  runs 2 through  $n$ ( $n-1$  through 1). When Phase 1 has been terminated with Down (Up) procedure, Phase 2 starts with Down (Up) procedure. (See Fig.5)

#### 4.5 Determination of horizontal positions of vertices (Step V)

[8]

PR method is a practical method which is developed to reduce the computing cost needed to obtain horizontal positions of vertices that realize a readable layout of a given  $n$ -level hierarchy. When we put  $x^i = (x_1^i, \dots, x_{|V_i|}^i)$ , the algorithm is outlined in the following:

- 1) Initial values of horizontal positions of vertices in each level are given by

$$x_k^i = x_0 + k, k=1, \dots, |V_i|, i=1, \dots, n. \quad (4-2)$$

- 2) Positions of vertices in each level are improved in the order of levels  $2, \dots, n, n-1, \dots, 1, t, \dots, n$  where  $t$  is a given integer

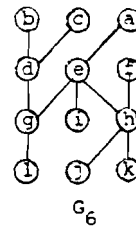
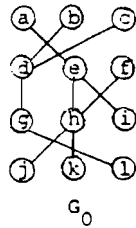

(1)  $\mathcal{G}_0$  is the initial matrix realization of  $G_0$ .

$$\mathcal{G}_0 = \begin{array}{c} \begin{array}{ccc|ccc|ccc} & \text{d} & \text{e} & \text{f} & & \text{g} & \text{h} & \text{i} & & \text{j} & \text{k} & \text{l} \\ \text{a} & 0 & 1 & 0 & 0 & \text{d} & 1 & 0 & 0 & 0 & \text{g} & 0 & 0 & 0 & 1 \\ \text{b} & 1 & 0 & 0 & 0 & \text{e} & 1 & 1 & 1 & 1 & \text{h} & 1 & 1 & 0 & 0 \\ \text{c} & 1 & 0 & 0 & 0 & \text{f} & 0 & 1 & 0 & 0 & \text{i} & 0 & 0 & 0 & 0 \end{array} \\ \begin{array}{ccc} 2 & 5 & 1 \end{array} \end{array} \quad \begin{array}{c} \text{M}^{(1)} \quad \text{M}^{(2)} \quad \text{M}^{(3)} \\ \text{K}(\mathcal{G}_0) = 5 \end{array}$$

(2) By reordering vertices d,e (columns d,e of  $M^{(1)}$  and rows d,e of  $M^{(2)}$ ) in  $\mathcal{G}_0$ ,  $\mathcal{G}_1$  is obtained. (Start of Phase 1-Down)

$$\mathcal{G}_1 = \begin{array}{c} \begin{array}{ccc|ccc|ccc} & \text{e} & \text{d} & \text{f} & & \text{g} & \text{h} & \text{i} & & \text{j} & \text{k} & \text{l} \\ \text{a} & 1 & 0 & 0 & 0 & \text{e} & 1 & 1 & 1 & 1 & \text{g} & 0 & 0 & 0 & 1 \\ \text{b} & 0 & 1 & 0 & 0 & \text{d} & 1 & 0 & 0 & 0 & \text{h} & 1 & 1 & 0 & 0 \\ \text{c} & 0 & 1 & 0 & 0 & \text{f} & 0 & 1 & 0 & 0 & \text{i} & 0 & 0 & 0 & 0 \end{array} \\ \begin{array}{ccc} 1 & 2 & 5 \end{array} \quad \begin{array}{ccc} 1 & 5 & 2 \end{array} \end{array} \quad \begin{array}{c} \text{K}(\mathcal{G}_1) = 5 \end{array}$$

(3) By reordering vertices g,h,i in  $\mathcal{G}_1$ ,  $\mathcal{G}_2$  is obtained.

$$\mathcal{G}_2 = \begin{array}{c} \begin{array}{ccc|ccc|ccc} & \text{e} & \text{d} & \text{f} & & \text{i} & \text{g} & \text{h} & & \text{j} & \text{k} & \text{l} \\ \text{a} & 1 & 0 & 0 & 0 & \text{e} & 1 & 1 & 1 & 1 & \text{i} & 0 & 0 & 0 & 0 \\ \text{b} & 0 & 1 & 0 & 0 & \text{d} & 0 & 1 & 0 & 0 & \text{g} & 0 & 0 & 0 & 1 \\ \text{c} & 0 & 1 & 0 & 0 & \text{f} & 0 & 0 & 0 & 1 & \text{h} & 1 & 1 & 0 & 0 \end{array} \\ \begin{array}{ccc} 1 & 1 & 5 \end{array} \quad \begin{array}{ccc} 2 & 3 & 3 \end{array} \end{array} \quad \begin{array}{c} \text{K}(\mathcal{G}_2) = 3 \end{array}$$

(4) By reordering vertices j,k,l in  $\mathcal{G}_2$ ,  $\mathcal{G}_3$  is obtained. (End of Phase 1)

$$\mathcal{G}_3 = \begin{array}{c} \begin{array}{ccc|ccc|ccc} & \text{e} & \text{d} & \text{f} & & \text{i} & \text{g} & \text{h} & & \text{l} & \text{j} & \text{k} \\ \text{a} & 1 & 0 & 0 & 0 & \text{e} & 1 & 1 & 1 & 1 & \text{i} & 0 & 0 & 0 & 0 \\ \text{b} & 0 & 1 & 0 & 0 & \text{d} & 0 & 1 & 0 & 0 & \text{g} & 1 & 0 & 0 & 1 \\ \text{c} & 0 & 1 & 0 & 0 & \text{f} & 0 & 0 & 0 & 1 & \text{h} & 0 & 1 & 1 & 2 \end{array} \\ \begin{array}{ccc} 1 & 2 & 5 \end{array} \quad \begin{array}{ccc} 1 & 1 & 5 \end{array} \quad \begin{array}{ccc} 2 & 3 & 3 \end{array} \end{array} \quad \begin{array}{c} \text{K}(\mathcal{G}_3) = 1 \end{array}$$

(5) Although vertices j,k of which barycenters are equal are reordered in  $\mathcal{G}_3$ , same matrices are obtained ( $\mathcal{G}'_3$ ). (Phase 2-Down)

(6) By reordering vertices e,d in  $\mathcal{G}'_3$ ,  $\mathcal{G}_4$  is obtained. (Start of Phase 2-Up)

$$\mathcal{G}_4 = \begin{array}{c} \begin{array}{ccc|ccc|ccc} & \text{d} & \text{e} & \text{f} & & \text{i} & \text{g} & \text{h} & & \text{l} & \text{k} & \text{j} \\ \text{a} & 0 & 1 & 0 & 0 & \text{d} & 0 & 1 & 0 & 0 & \text{i} & 0 & 0 & 0 & 0 \\ \text{b} & 1 & 0 & 0 & 0 & \text{e} & 1 & 1 & 1 & 1 & \text{g} & 1 & 0 & 0 & 1 \\ \text{c} & 1 & 0 & 0 & 0 & \text{f} & 0 & 0 & 0 & 1 & \text{h} & 0 & 1 & 1 & 2 \end{array} \\ \begin{array}{ccc} 2 & 1 & 5 \end{array} \quad \begin{array}{ccc} 2 & 3 & 3 \end{array} \end{array} \quad \begin{array}{c} \text{K}(\mathcal{G}_4) = 3 \end{array}$$

(7) By reordering rows a,b,c in  $\mathcal{G}_4$  (Phase 1-Up),  $\mathcal{G}_5$  is obtained.

$$\mathcal{G}_5 = \begin{array}{c} \begin{array}{ccc|ccc|ccc} & \text{d} & \text{e} & \text{f} & & \text{i} & \text{g} & \text{h} & & \text{l} & \text{k} & \text{j} \\ \text{b} & 1 & 0 & 0 & 0 & \text{d} & 0 & 1 & 0 & 0 & \text{i} & 0 & 0 & 0 & 0 \\ \text{c} & 1 & 0 & 0 & 0 & \text{e} & 1 & 1 & 1 & 1 & \text{g} & 1 & 0 & 0 & 0 \\ \text{a} & 0 & 1 & 0 & 0 & \text{f} & 0 & 0 & 0 & 1 & \text{h} & 0 & 1 & 1 & 2 \end{array} \\ \begin{array}{ccc} 1 & 5 & 3 \end{array} \quad \begin{array}{ccc} 2 & 1 & 5 \end{array} \end{array} \quad \begin{array}{c} \text{K}(\mathcal{G}_5) = 1 \end{array}$$

(8) By reordering columns i,g in  $\mathcal{G}_5$  (Phase 1-Down),  $\mathcal{G}_6$  is obtained. (End of Phase 2)

$$\mathcal{G}_6 = \begin{array}{c} \begin{array}{ccc|ccc|ccc} & \text{d} & \text{e} & \text{f} & & \text{g} & \text{i} & \text{h} & & \text{l} & \text{k} & \text{j} \\ \text{b} & 1 & 0 & 0 & 0 & \text{d} & 1 & 0 & 0 & 0 & \text{g} & 1 & 0 & 0 & 0 \\ \text{c} & 1 & 0 & 0 & 0 & \text{e} & 1 & 1 & 1 & 1 & \text{i} & 0 & 0 & 0 & 0 \\ \text{a} & 0 & 1 & 0 & 0 & \text{f} & 0 & 0 & 0 & 1 & \text{h} & 0 & 1 & 1 & 2 \end{array} \\ \begin{array}{ccc} 1 & 5 & 3 \end{array} \quad \begin{array}{ccc} 1 & 5 & 2 \end{array} \quad \begin{array}{ccc} 2 & 3 & 3 \end{array} \end{array} \quad \begin{array}{c} \text{K}(\mathcal{G}_6) = 0 \end{array}$$

Fig.5 An application of the n-level BC method.

(2)  $t \leq n-1$ ). The improvements of the positions of vertices in levels  $2, \dots, n$  and  $t, \dots, n$  are called Down procedures, while those for levels  $n-1, \dots, 1$  are called Up procedure.

- 3) Positions of vertices are determined one by one according to its priority number. The highest priority number is given to dummy vertices to improve the readability element  $e$ . Priority numbers of the other vertices are defined according to the connectivities given by (3-10) or (3-11).
- 4) The principle to improve the position of a vertex is to minimize the difference between the present position of the vertex and the upper(or lower) barycenter given by (3-8) (or (3-9)) of the vertex in Down(orUp) procedure under the following conditions:
  - a) The position of the vertex should be integer and can not be equal to the positions of other vertices.
  - b) The order of vertices of each level should be preserved.
  - c) Positions of only vertices of which priorities are less than the priority of the vertex can be changed, where the distance displaced should be as small as possible.

The details of the algorithm are illustrated in Fig.6.

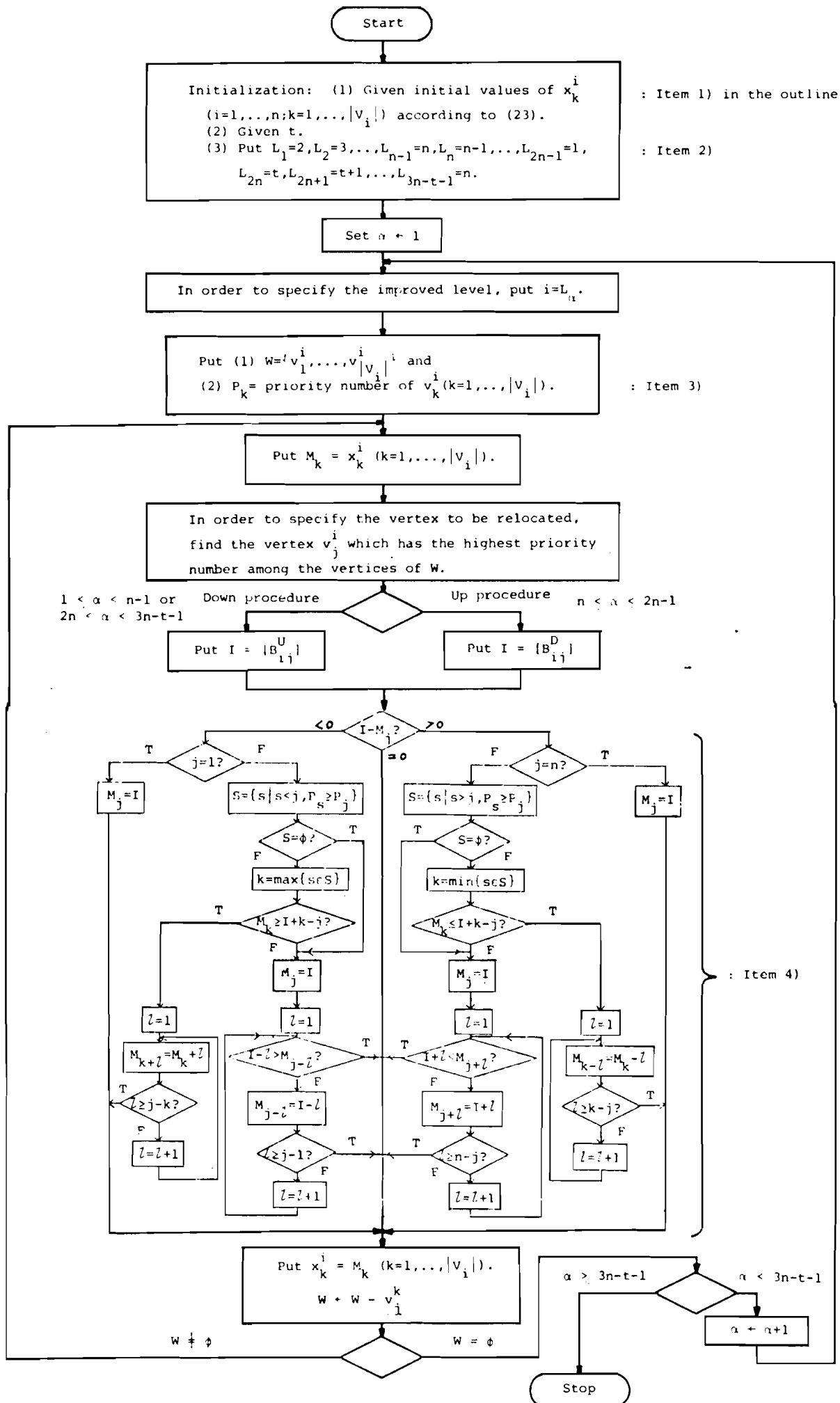

: Item 4)

Put  $x_k^i = M_k$  ( $k=1, \dots, |V_i|$ ).

$W = W - v_i^k$

$W \neq \emptyset$

$W = \emptyset$

$\alpha > 3n-t-1$        $\alpha < 3n-t-1$

$\alpha \leftarrow \alpha + 1$

Fig.6 Flow diagram of the algorithm of PR method.

### 5. How to Use SKETCH System

Commands for UNIX version of SKETCH system are very simple:

```

%sketch.x 5=input-file-name (calculation)
%cat SKETCH (display on graphics)
%di-bbc <SKETCH >SKETCH1 } (plot on XY-plotter)
%p -pri:bbc SKETCH1

```

Before using SKETCH system we should prepare an input file which gives information for drawing as follows.

#### A. Data for the layout of a hierarchy

```

ihv   intvlh   intvlv   lvpara   iarr   fact
(i4)  (i4)     (i4)     (i4)     (i4)   (f4.0)

```

(i) ihv = {0 | an integer except 0} : This parameter specifies whether vertices are arranged horizontally or vertically on a screen of a graphic terminal.

0 : horizontally                      otherwise : vertically

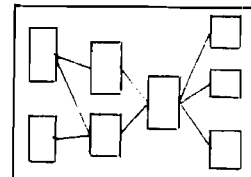
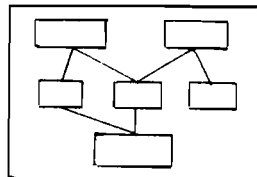

(ii) intvlh = a non-negative integer : The minimum length between adjacent vertices on a level is specified, where a unit is set to be equal to the width of a character drawn in labels of vertices. If we give 0 for intvlh, then a default value(=3) is specified by the system.

(iii) intvlv = a non-negative integer : The length between adjacent levels is specified, where a unit is set to be equal to the height of a character drawn in labels of vertices.

If we give 0 for `intvlv`, then a default value(=3) is specified by the system.

(iv) `lvpara` = an integer between 0 and the number of levels :  
This parameter specifies the parameter `t` explained in Section 5.4. If we give 0 for `lvpara`, a default value 3 is specified by the system.

(v) `iarr` = {0|1|2|3|4|5|6|10|11|12|13|14|15|16} : This parameter specifies kinds of edges by the numbers of the first (a) and the second(b) digits of `iarr` (=a×10+b) as follows.

the number of second digit (b)

- 0 : without an arrowhead
- 1 : with an arrowhead (down) at the lower end
- 2 : with an arrowhead (up) at the upper end
- 3 : with two arrowhead (down and up) in both ends
- 4 : with arrowheads (down) at each level in the case of long span edges
- 5 : with arrowheads (up) at each level in the case of long span edges
- 6 : with arrowheads (down and up) at each level in the case of long span edges

the number of first digit (a)

- 0 : a real line
- 1 : a dotted line

(vi) `fact` = a real number between 0.0 and 1.0 : This parameter specifies a reducing factor for drawing. When we give 0.0 or 1.0 for `fact`, then full screen is used for drawing.

## B. Data for vertices

The following data is given for each vertex, where the order



of vertices is free.

name	shape	label-1
(a3)	(i1)	(a76)
	label-2	(continued)
(4x)	(a76)	
	label-3	(continued)
(4x)	(a50)	

(i) name = any three characters including spaces : This parameter specifies an internal name of each vertex. The name is used in expressing edges in C.

(ii) shape = {0|1} : This parameter specifies a shape of each vertex. (in other version we prepare more kinds of shapes.)



(iii) label-1<sup>\*)</sup> : a character string ( $\leq 76$  characters) : This parameter specifies a label of each vertex. If the number of characters of the label is greater than 76, then the last character should be put "\*" and the string is continued to the next line(label-2).

(iv) label-2<sup>\*)</sup> = continuing character string ( $\leq 76$  characters) : If the length of the string is greater than 152, then the last character should be put "\*" and the string is continued to the next line(label-3).

(v) label-3<sup>\*)</sup> = continuing character string ( $\leq 50$  characters)

\*) A line-control of labels is carried out by backspaces(\s) in the character string. If a backspace appears in the string, the string following the backspace is drawn in a new line.

The backspaces are not drawn.

C. Data for edges

```
//
name-out      name-in      miarr
(a3)          (1x)         (a3)         (2x)         (i2)
.
.
.
.
```

(i) name-out = name of a vertex : This parameter specifies an out-vertex of each edge and so it should correspond to one of names defined in B.

(ii) name-in = name of a vertex : This parameter specifies an in-vertex of each edge and so it should correspond to one of names defined in B.

(iii) miarr = {0|1|2|3|4|5|6|10|11|12|13|14|15|16} : If we want to specify the kind of a edge which is different from the kind specified by a parameter iarr, we can use this parameter for modification.

D. Data for specifying levels of vertices

When we do not give this data, SKETCH system determines the levels of vertices according to a standard level assignment method. However, we want to give the levels of vertices specially (of course, this can not be contradict with a hierarchization), we use this function as follows.

```
//
lev
(i4)          : the number of levels

li(k), (k=1,lev)
(18i4)       : the number of vertices on the
               kth level
```

nn(1,k), (k=1,lev) : the number of the kth vertex  
(18i4) 1st level  
.  
:  
.  
nn(lev,k), (k=1,li(lev)) : the number of the kth vertex  
(18i4) levth level

## 6. Applications

### 6.1 Predator-prey ecosystem

When we express such a relation that A preys B by  $A \rightarrow B$ , we can use a directed graph to represent a predation relation among species in a predator-prey ecosystem. An example is shown in Fig.7, which seems to be drawn in a two-dimensional surface manually. However, the predation relation contains a hierarchical structure within it intrinsically. Therefore it is more reasonable to represent the relation in a hierarchical form. For this purpose SKETCH system is a very convenient tool and we get Fig.8, where input data given to SKETCH system also is shown. From Fig.8

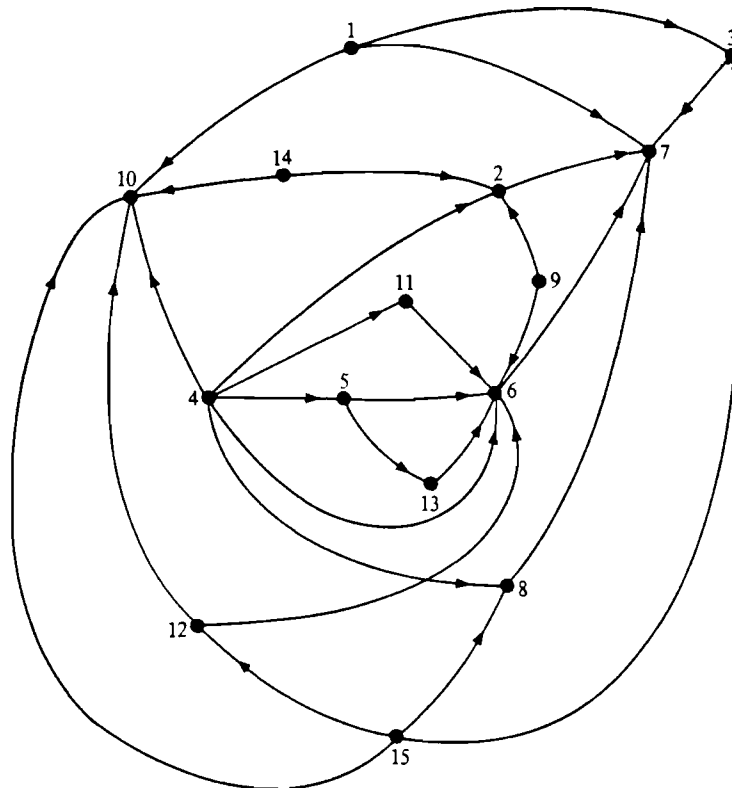

- Key:
- |                |            |                |
|----------------|------------|----------------|
| 1. Bear        | 6. Insect  | 11. Salamander |
| 2. Bird        | 7. Plant   | 12. Skunk      |
| 3. Deer        | 8. Rabbit  | 13. Toad       |
| 4. Fox         | 9. Raccoon | 14. Wildcat    |
| 5. Gartersnake | 10. Rodent | 15. Wolf       |

Fig.7 Predator-prey ecosystem. (Source: Casti 1979)

0 0 0 6 1 1 0

11 bear  
 21 bird  
 31 deer  
 41 fox  
 51 cartersnake  
 61 insect  
 71 plant  
 81 rabbit  
 9 racoon  
 10 rodent  
 11 salamander  
 12 skunk  
 13 toad  
 14 wildcat  
 15 wolf  
 //

1 3  
 1 7  
 1 10  
 2 7  
 3 7  
 4 2  
 4 5  
 4 6  
 4 8  
 4 10  
 4 11  
 5 6  
 5 13  
 6 7  
 8 7  
 9 2  
 9 6  
 11 6  
 12 6  
 12 10  
 13 6  
 14 2  
 14 10  
 15 3  
 15 8  
 15 10  
 15 12

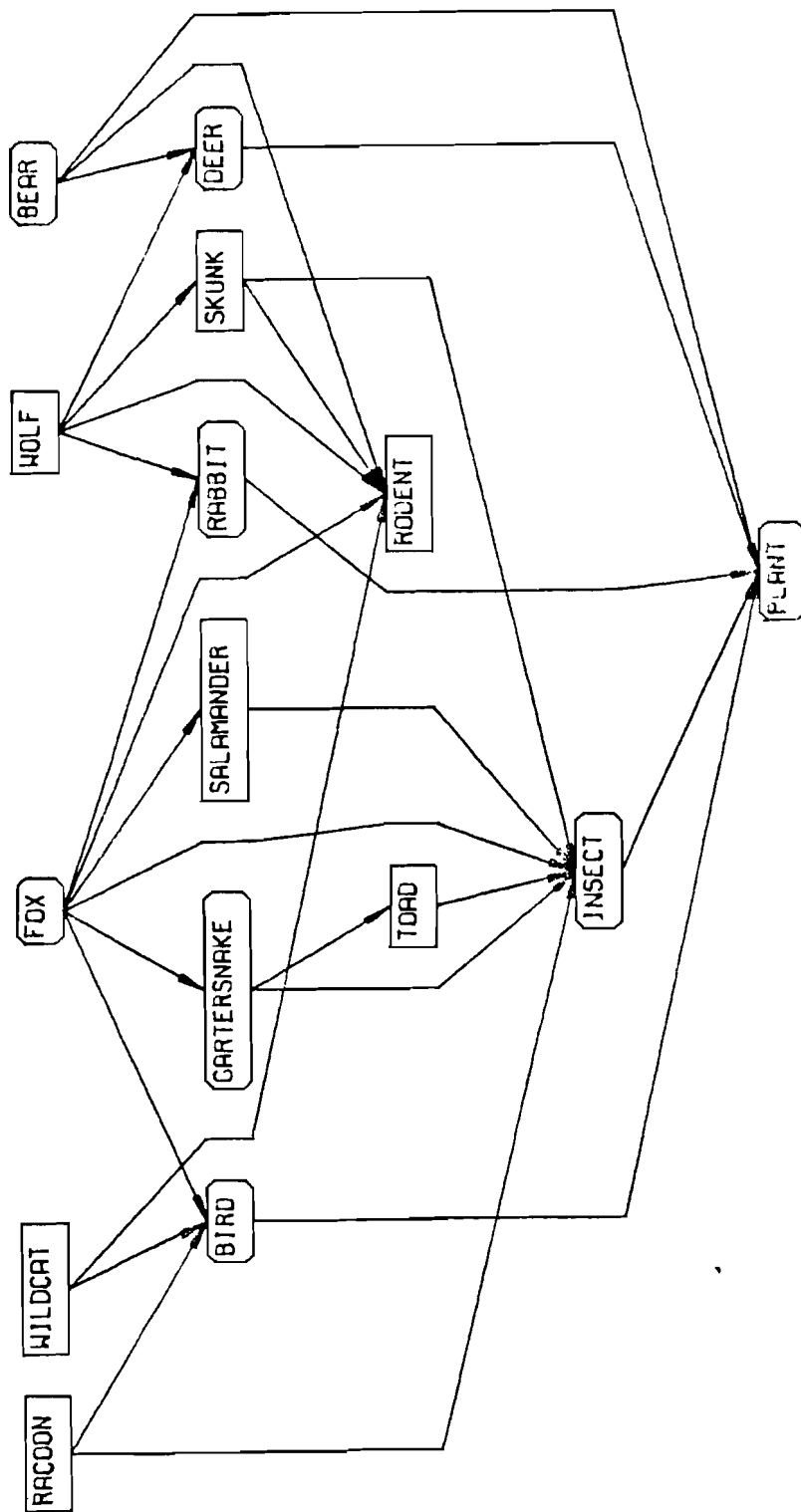

Fig.8 Hierarchical representation of the predator-prey ecosystem.

we can easily see that this ecosystem has 5 levels of food chains, that Plant and Rodent do not attack other species and that Raccoon, Wildcat, Fox, Wolf and Bear are not attacked by the rest.

## 6.2 Call structure in a FORTRAN program [10]

In FORTRAN programs recursion or feedback-call is inhibited due to its grammar and therefore the call structures in FORTRAN programs always are hierarchical. When the program is large in scale, it is quite convenient to represent the call structures as drawings for modifying or explaining. For example, SKETCH system is constituted from a main program and 29 subroutines. This structure is drawn in Fig.9, where we can know that the depth of this program is 5 levels, that subroutines PLSKTH and PLSKTV are symmetric and that on the whole the structure is well-separated.

## 6.3 SD(System Dynamics) diagrams [12]

We denoted a scheme of the double layout in Step I to obtain a hierarchy. We present an example of this scheme which can illustrate effectively the dependence of the variables of system dynamics. The diagram in Fig.10(a) shows the schematic relations of the variables that have been used to simulate the future dynamics of the world(Forrester 1971). A two-dimensional diagram for system dynamics contains cycles, but a cycle contains at least one level variable (e.g. variable denoted by rectangular vertices in Fig.10(a)) due to a constraint imposed by a DYNAMO compiler. Therefore, the cycles can be eliminated by drawing the level variables twice as described below.

The digraph can then be represented by a hierarchical map.

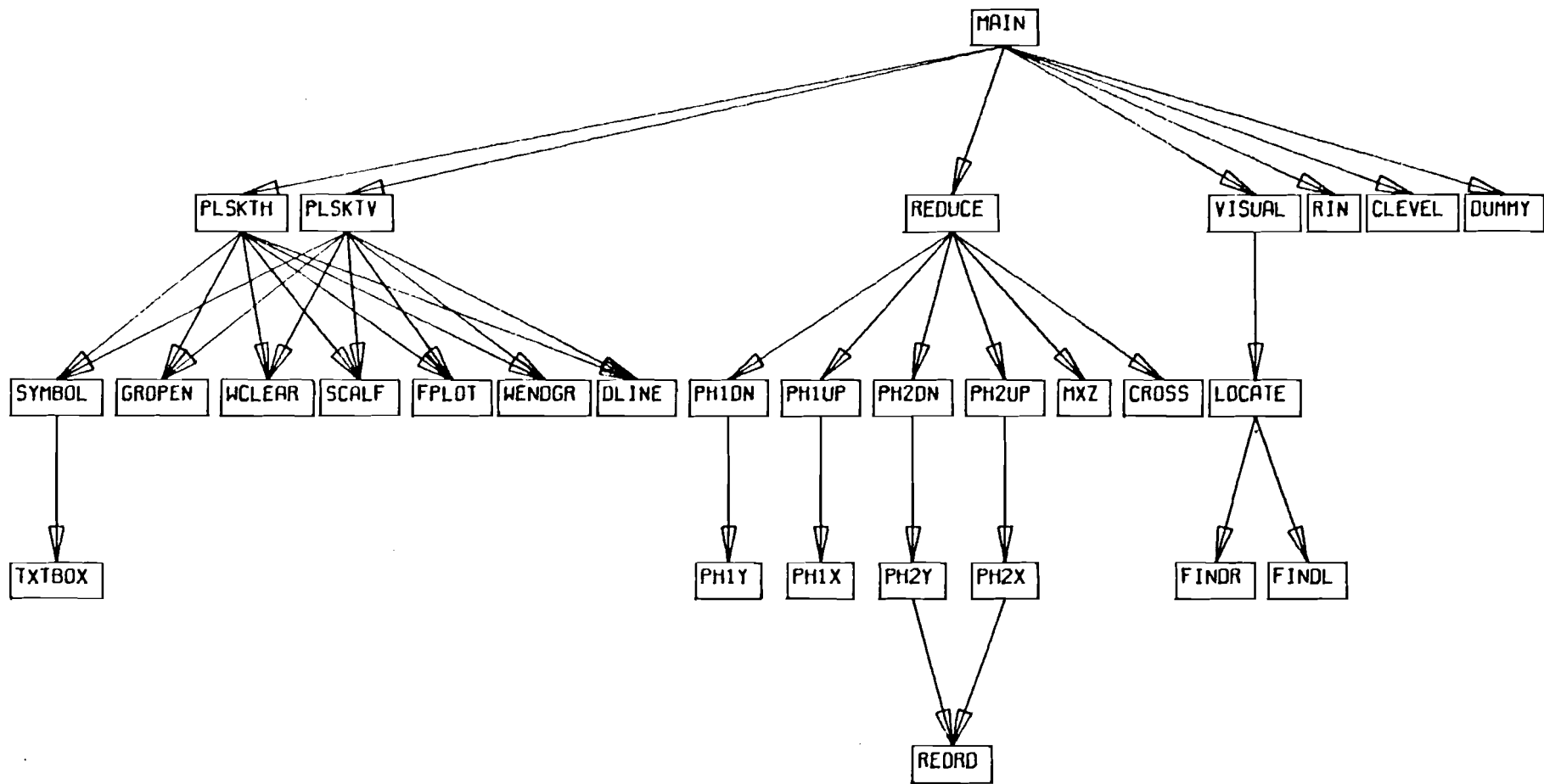
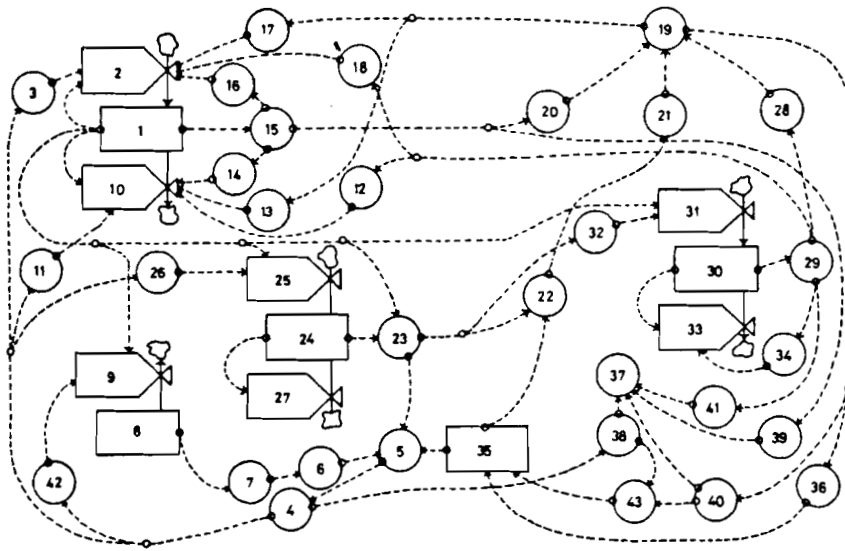
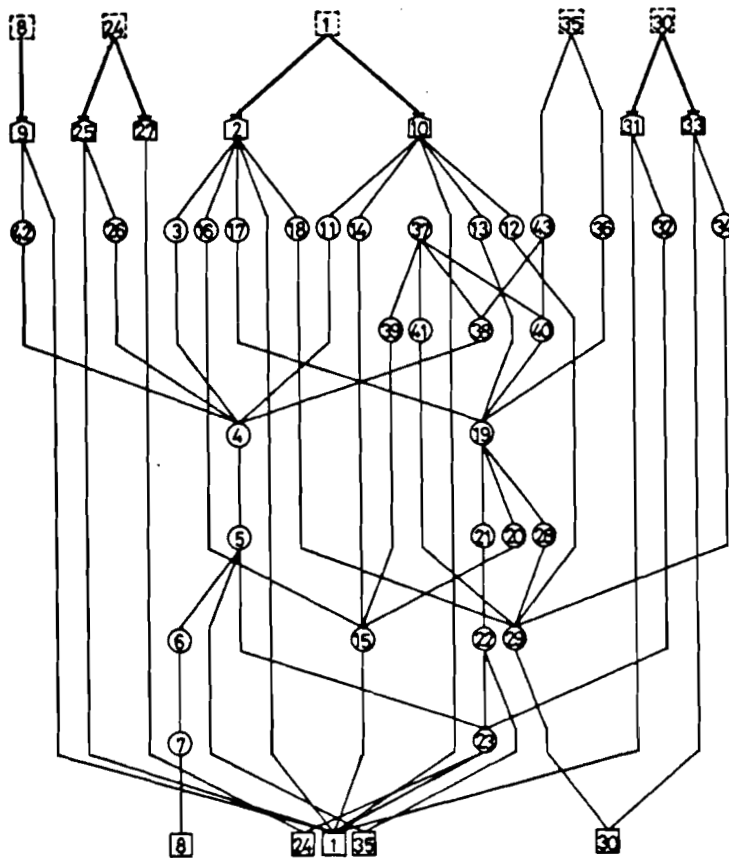

Fig.9 Call structure among subroutines of SKETCH system.



(a)



(b)

Fig.10 (a) Diagram of the world model.  
(b) Hierarchical representations of the world model.



An application of SKETCH system to the map resulted in the drawing in Fig.10(b). The bottom vertices(solid line square vertices) in Fig.10(b) denote the level variables at some time, and the top vertices (broken line square vertices) are the same variables after the unit-time of the simulation. Since the vertices at the top and bottom levels denote the same variables, it is desirable to locate the vertices in the same order. The definition of recurrent hierarchies in [12] enabled the application of SKETCH system to the hierarchy.

Note that Fig.10(b) exhibits the order by which auxiliary variables(circular vertices) are determined only after all the lower level variables have been determined that are connected to the variable.

It may be difficult to determine which figure, Fig.10(a) or (b), is more effective in representing the simulation model. Considering that (a) was manually drawn to communicate the simulation model to human readers, and that (b) was automatically drawn by a computer, we might justify that (b) is a reasonably good representation of the model.

#### 6.4 Research trends observed in citations among literatures [1,2]

Kitagawa et al.[1] proposed a method utilizing citations among concerning literatures to recognize the trend of researches in a discipline, where the visual representation of the reference relations by machine was strongly desired.

When a set of literatures is denoted by  $P=\{p_1, p_2, \dots, p_n\}$ , citations are expressed by a set  $Q$  of ordered pairs of citing literature and cited literature, i.e.  $Q \subset P \times P$ . Consequently, the

citations can be regarded as a digraph  $G(P,Q)$ . However, if we represent directly the hierarchy obtained from the digraph, it is often too complicated to understand the structure embedded in the digraph(See Fig.11(b)). Therefore, we need a method for extracting a more simplified structure from the digraph. For this purpose we extract a skeleton digraph  $G'=(P,Q')$  from  $G$  by eliminating any edge  $e=(v,w) \in Q$  if there exists another path(sequence of edges) from  $v$  to  $w$ . Further,  $G'$  is converted into a hierarchy  $G''=(P,Q',n)$  and any edge  $e \in Q'$  is eliminated if a span of  $e$  is greater than 1. As a consequence we get  $G'''=(P,Q'',n)$ .

Asano(Kyushu Univ.) and Sugimura(Ooita Univ.) collected a set of literatures concerning the theory of successive process of statistical inferences, which are ranging from 1944 to 1977, and obtained a set of citations (or digraph  $G$ ) presented Fig.11(a). When the citations are drawn in a hierarchical form, we get a very complicated map shown in Fig.11(b). We obtain  $G''$  and  $G'''$  from  $G$ , and maps of  $G''$  and  $G'''$  are shown in Fig.12(a) and (b), respectively. Fig.12(c) shows a map of a hierarchy obtained by re-assigning the levels of  $G'''$  according to the year when each literature(vertex) was published. These maps shown in Fig.12 suggest well the development and the relationships of researches in the specific discipline.

## 6.5 Earthquake disaster relational model [3]

Recent industrialization and urbanization change social conditions significantly so that the risk potential of earthquake disaster seems to become extremely high. It is especially true for the Japanese Islands which are located on a highly active

(A)	3		(B)	58	45
	5	1, 2		59	1, 3, 5, 49
	6	1, 3		60	3
	7	5		61	55, 56, 57
	8	2		62	20, 36, 37, 55
	9	10		64	22, 51
	10	5, 7		65	1, 3, 45, 49, 59
	11	2, 5, 7, 10		66	25
	13	2, 5, 7, 11		68	1
	15	5, 7, 10, 11		69	1, 5, 6, 7, 12, 20, 21, 22, 29, 45, 58
	16	5, 7, 10, 11, 14, 15		70	5, 7, 10, 11, 15, 16
	17	2		72	1, 20, 71
	18	1, 6		73	1, 3, 6, 41
	19	5, 14		75	60
	20	1, 3, 5, 6		76	6, 59, 64
	21	5, 12		77	51
	22	1, 3, 5, 7		78	51
	23	4, 5, 7, 9, 10, 11, 14, 15, 16, 19		79	1, 3, 21, 32, 37, 45
	24	5, 9		80	1, 3, 6, 22
	25	5, 7, 10, 11, 15, 16, 19		82	45, 65
	26	24		83	1, 22, 29, 40, 47
	27	9		85	1
	28	24, 26, 27		86	1, 63, 64
	29	1, 5, 6, 20, 22		87	78
	30	1, 5, 6, 29		88	49
	31	2, 11, 13		90	85
	32	1, 5, 15, 22		91	1, 3, 7, 20, 44, 47, 50, 51, 68, 94
	33	5, 12, 22		92	1, 3, 45, 49, 51, 63, 65
	36	1, 5, 19, 23, 32		93	1, 3, 45, 59, 65
	37	1, 5, 15, 18, 32, 36		94	47, 68, 89
	38	23, 28, 29		95	23, 45
	39	1, 5, 12, 32		96	1, 20, 49, 79
	41	3, 20, 22		97	6, 51, 59, 64, 76
	42	3		99	89
	43	1, 5, 12, 22, 32, 39		100	41
	44	5, 23, 38, 40, 45, 46		101	42, 78, 87
	45	1, 3, 5, 6, 7, 8, 10, 14, 15, 16, 18, 19, 20, 22, 23, 25, 29, 30, 32, 33		102	22, 60, 83
	46	5, 7, 10, 11, 15, 16		103	1, 6, 22
	47	1, 3, 7, 21, 22, 29, 48		106	1, 6, 65, 91, 94, 108
	48	1, 3, 6, 7, 20, 21, 22, 29		108	89
	49	1, 3, 7, 20, 21, 22, 29, 31, 37, 41, 45, 47		110	1, 42, 65, 78, 83, 87, 101
	50	40, 45, 51		111	20, 68, 89, 91, 94, 106, 108
	51	22, 45		112	45, 91
	52	5, 22, 23, 29, 38, 44, 45		113	1, 32, 106
	53	28		114	5, 65
	54	1, 3, 21, 47		115	1, 3, 5, 20, 45, 49, 59, 65, 91, 99
	55				

(a)

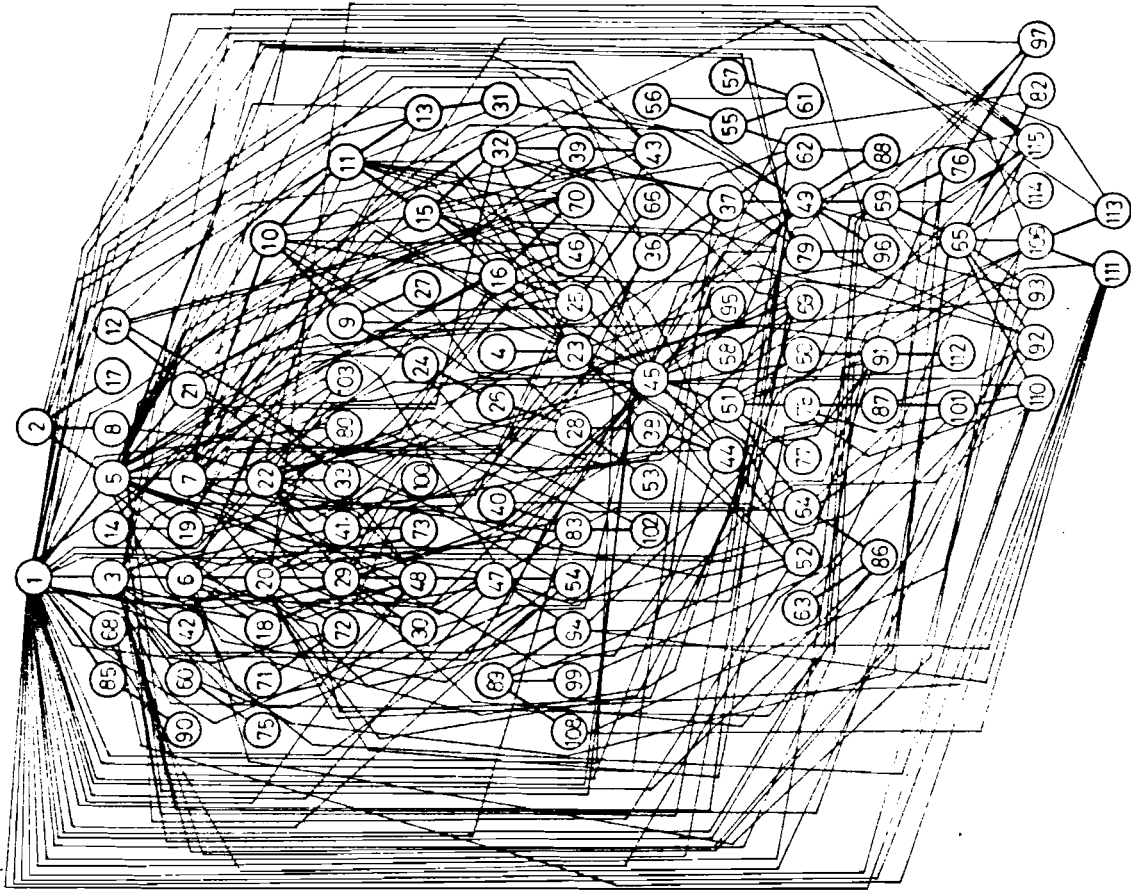

(b)

Fig. 11 (a) Citations(A cites B). (b) A map of citation graph (by hand).

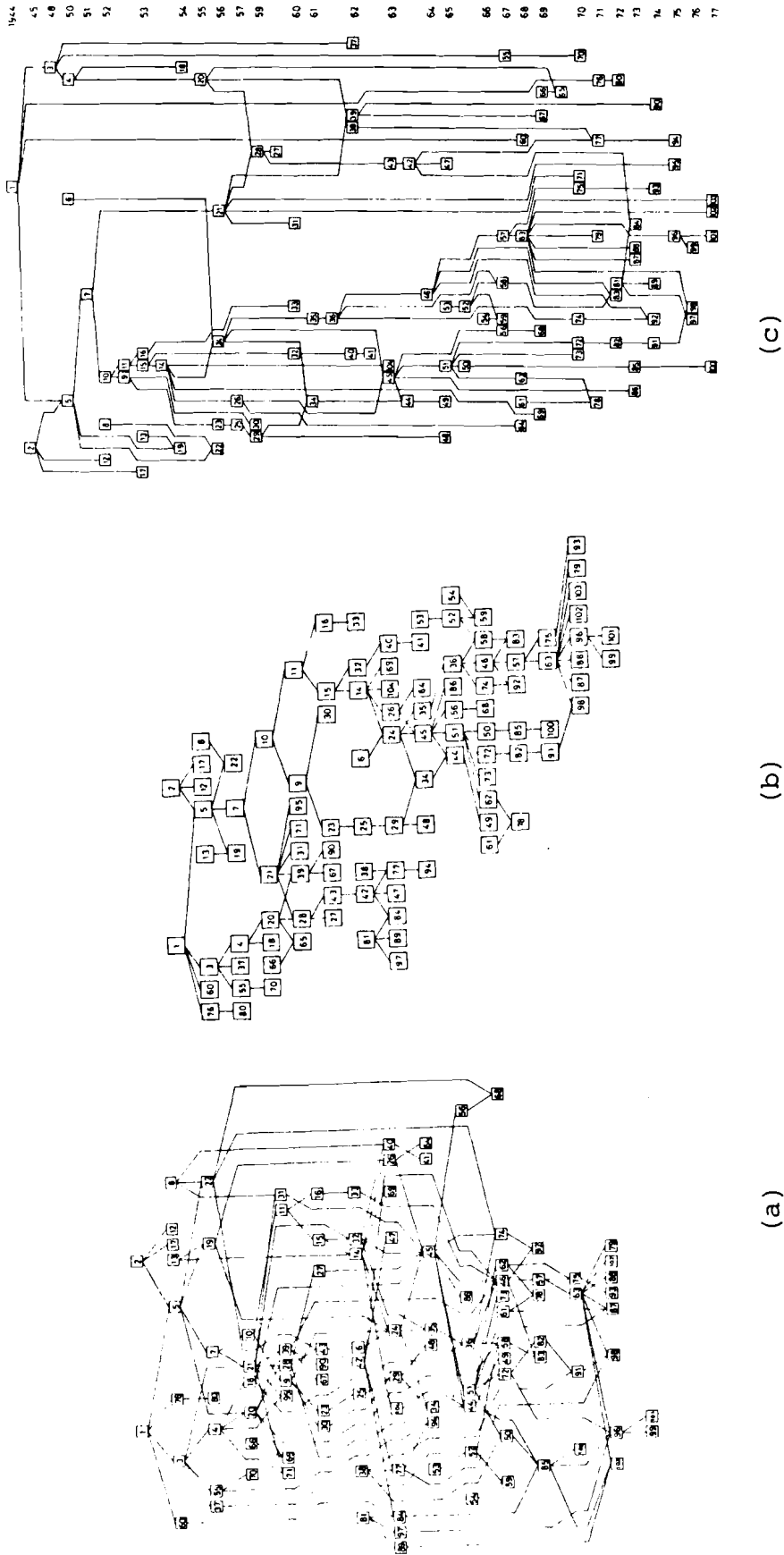

Fig.12 (a) Skeleton structure. (b) Structure extracted from (a).  
(c) Representation of (b) along the time axis.

seismic zone.

It is well known that an earthquake is a natural phenomenon and we can not stop its occurrence. We can only have the possibility to predict it. On the other hand, an earthquake disaster is a social phenomenon triggered by the natural phenomenon. Therefore, we can reduce it if we can predict the occurrence and cut the chains of propagation of disaster. However, how to express and communicate information on earthquake prediction is not easy because panics may be caused. Moreover, since the earthquake disaster have a very complicated structure, it is very difficult to find critical chains. Because the earthquake disaster is characterized as the integrated disasters and the time for counter-actions is limited. Therefore, it is especially desirable to recognize the structure of the whole system, even if we can not know quantitative behaviors of the system.

A qualitative model of relations among forecast, anti-disaster actions, occurrence of earthquake, propagation of disasters and so on, is developed through the brain-storming and surveys of questionnaires, laws, and journals and newspapers describing on the disaster due to the earthquake occurring near the Izu Islands on Jan. 14, 1978 (Izu Ohshima Knkai Jishin). This model is composed of a set of simple relations between two events such as

$$A \omega B ; \{>, <, <>, =\}$$

where  $>(<)$  : Event A(B) causes event B(A) or event B(A) is performed after event A(B).

= : Event A is equivalent to event B.

Nineteen units (forecast unit, policy unit, enterprise unit, home unit, etc.) are distinguished and about 300 elemental relations

among about 170 events are listed up. Further, as an extension of the above model we distinguish types of relation according to the model of  $A\omega B(\psi)$  as

$$\psi \in \{\text{procedure, causality, operation}\}.$$

Since the number of relations is too many and the structure is also complicated, a computer-based technique is utilized to aid our understanding. For this purpose, the method called ISM(interpretive structural modeling) developed by Warfield(1976) is employed. Given the list of relations to the computer we can get a skeleton structure of the model in an hierarchical graphic form. Fig.13 shows the skeleton graph of relations in the earthquake disaster system where the loss of lives are utilized as an evaluation index of the risk. From Fig.13 interdependence among events and critical events can be found easily.

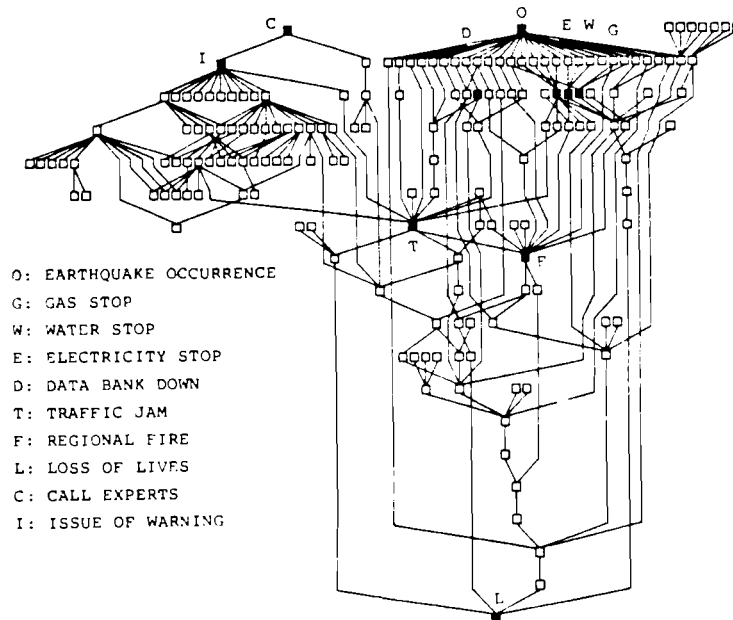

Fig.13 Skeleton graph of propagation structure of of earthquake disaster relational model.

6.6 Visual representation of national economy (I/O table)

I/O(input/output) tables of national economies have been prepared periodically according to an international standard form in many countries of the world and therefore they might be one of most convenient data for analysing and comparing economic structures and changes along the time axis or in cross-nations. However, since I/O tables are composed of many numerical data, it is difficult to recognize the structural information embeded in the tables readily. A method presented here can serve for representing holistic structures of national economies effectively without complicated data processing, where SKETCH system is used for drawing.

I/O table has the form shown by

from Industries		Final demand	Total
to	1.....j.....N		
Industries	1.....i.....N	$F_i$	$X_i$
	$P_{ij}$	$(F_i^i + F_i^e)$	$(X_i^d + X_i^m)$

where

$i, j$	$i, j$ th production sector or $i, j$ th product	$F_i^e$	export of $i$ th product
$N$	number of production sector	$F_i$	total final demand
$P_{ij}$	transfer of $i$ th product to $j$ th production sector	$X_i^d$	total amount of domestic production of $i$ th product
$P_{i.}$	intermediate demand of $i$ th product	$X_i^m$	import of $i$ th product
$F_i^i$	domestic final consumption of $i$ th product	$X_i$	total amount of $i$ th product

and we have

$$X_i^d + X_i^m = \sum_{j=1}^N P_{ij} + F_i^i + F_i^e \quad (6-1)$$

We extract a core structure embeded in a I/O table as follows.

- 1)  $\{P_{ij}\}$  is rearranged in the decreasing order as

$$a_1 \geq a_2 \geq \dots \geq a_k \geq \dots \geq a_m$$

where  $m=N \times N$  and  $a_k = P_{i_k j_k} \in \{P_{ij}\}$ .

- 2) We consider a threshold value  $\theta$  ( $0 < \theta \leq 100$ ) and  $k_\theta$  is determined by

$$t_{k_\theta - 1} \leq \theta \text{ and } t_{k_\theta} \geq \theta$$

where  $t_k = (a_1 + a_2 + \dots + a_k) / (a_1 + a_2 + \dots + a_m) \times 100$ .

- 3) We form a hierarchy  $G(V, E, n)$  by the following procedure.

step 1:  $k:=1$ ;  $V:=\phi$ ;  $E:=\phi$ .

step 2:  $V:=V \cup \{k\}$ ;  $E:=E \cup \{(i_k, j_k)\}$ .

step 3: If a level assignment of  $G(V, E)$  is possible, determine it; otherwise delete  $(i_k, j_k)$  from  $E$ , add  $(j_k, i_k)$  to  $E$  and determine a level assignment of  $G(V, E)$ . (In this step we get  $G(V, E, n)$ .)

step 4:  $k:=k+1$ .

step 5: If  $k > k_\theta$ , then terminate; otherwise go to step 2.

- 4) We draw the obtained hierarchy where original directions of the edges which are reversed in step 3 are used.

Core structures of Japanese economy in 1960 and 1975 are presented in Fig.14(b) and Fig.15 respectively, where we use I/O tables with 29 sectors as follows.

- 1 Agriculture, forestry and fishery
- 2 Mining
- 3 Food, drink manufacturing and tobacco
- 4 Spinning
- 5 Fiber and textile
- 6 Wood and furniture
- 7 Pulp and paper
- 8 Printing and publishing
- 9 Rubber and leather
- 10 Chemicals and medicine



- 11 Materials for chemical textile
- 12 Oil and coal products
- 13 Products from stone and clay
- 14 Iron and steel and non ferrous metal
- 15 Metal products
- 16 Ordinary machinery
- 17 Electric machinery
- 18 Transportation machinery
- 19 Precision machinery
- 20 Other manufacturings
- 21 Construction and civil engineering
- 22 Electricity, gas and water services
- 23 Commerce
- 24 Bank and insurance
- 25 Real estate
- 26 Transportation and communication
- 27 Public services
- 28 Business machinery and packing
- 29 Others

In both figures edges drawn by real lines mean 60% level economy (i.e.  $\theta=60$  and edges corresponding to  $a_1, \dots, a_{k_{60}}$  are drawn.), and edges drawn by real+dotted lines mean 70% level economy (i.e.  $\theta=70$  and edges corresponding to  $a_1, \dots, a_{k_{70}}$  are drawn.). Further, labels of vertices show names of sectors (upper row), supplies of products (middle row) and demands of products (lower row), and each symbol means

Supply (middle row)	Demand (lower row)
> : import ( $X_i^m$ )	+ : intermediate ( $P_i.$ )
* : domestic production ( $X_i^d$ )	- : final ( $F_i^i$ )
	> : export ( $F_i^e$ )

where one symbol corresponds to  $2.5 \times 10^{11}$  yen (nominal) in 1960 and  $1.25 \times 10^{12}$  yen (nominal) in 1975, respectively. Since deflators in 1960 and 1975 are 38 and 100 respectively, the figure obtained by reducing the size of Fig.14(b) into 0.53 times can be compared with Fig.15 in the net base, which also is shown in Fig.14(a). Octagons mean that corresponding vertices are included in strongly

connected components. From Figs.14 and 15, we can see that

(1) Both structures are almost similar in spite of apparent differences, which means that significant changes in the economic structure in terms of I/O table did not appear from 1960 to 1975.

(2) Relative increases in the tertial sectors such as construction, civil engineering, commerce, public services and real estates are remarkable in 1975 comparing with 1960.

(3) In secondary sectors it should be noted that productions and exports of transportation machineries, and transportation and communication are relatively increased in 1975.

Finally, though this paper shows only preliminary results, the cross-national research based on this method seems to be interesting, and therefore it is strongly envisaged as a useful application field and a subject suitable for IIASA.

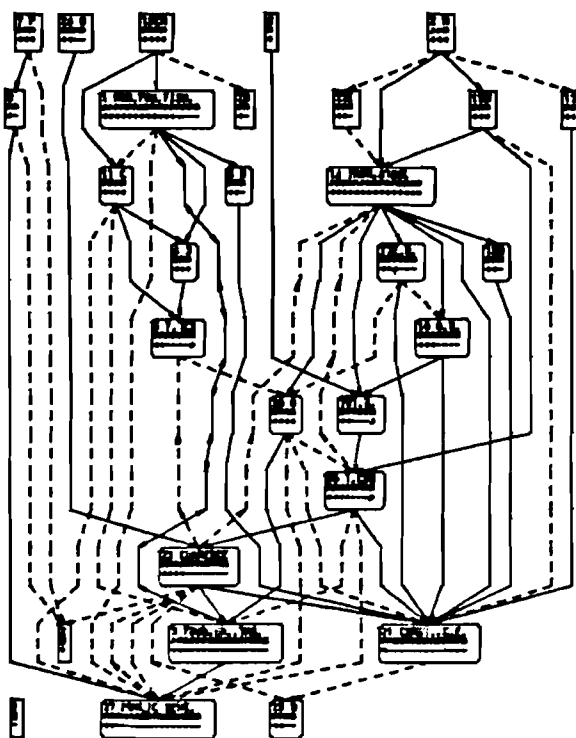

Fig.14(a) Structure of Japanese economy in 1960 drawn in comparing with 1975.

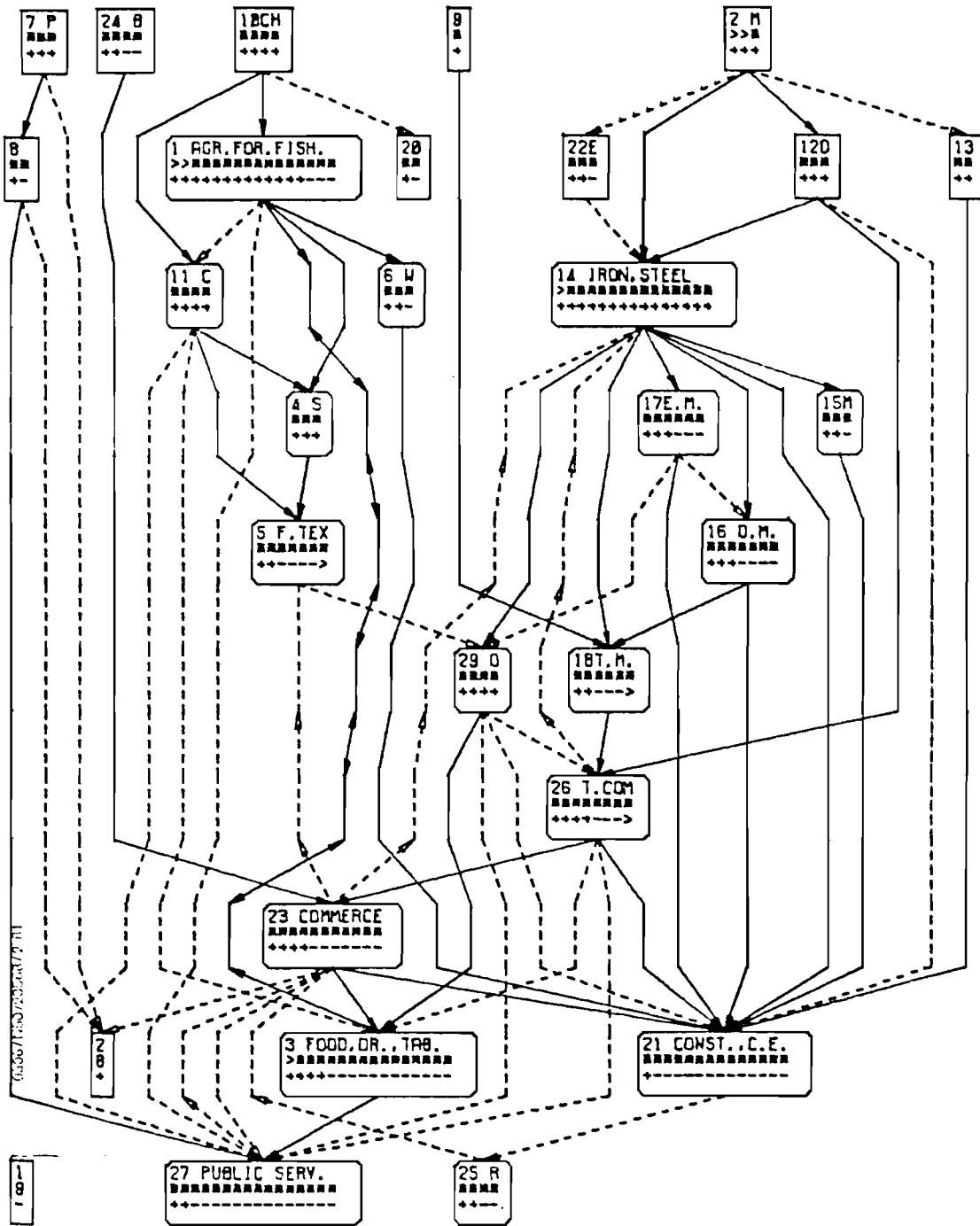

Fig.14(b) Structure of Japanese economy in 1960, enlarging the size of (a).

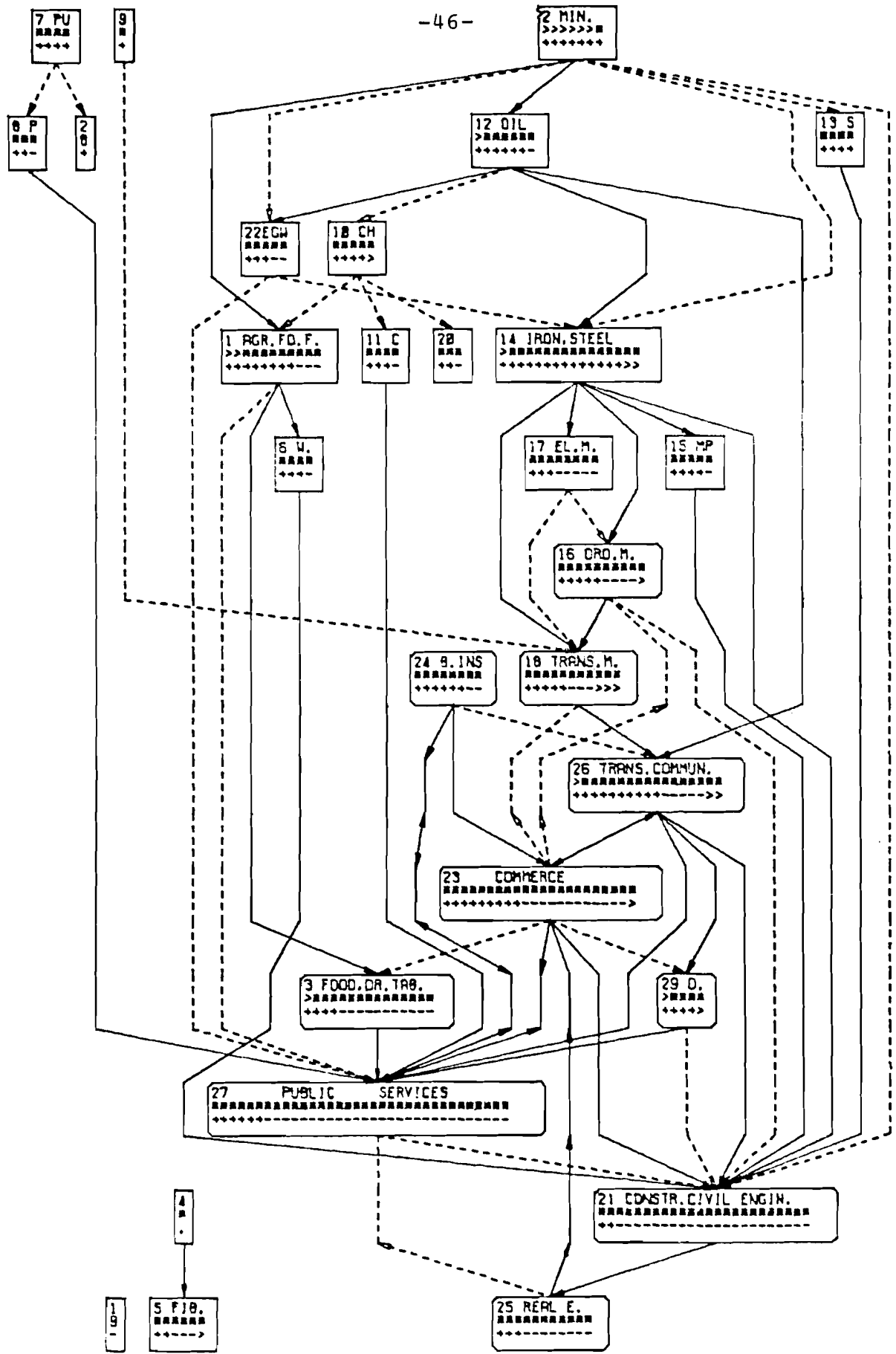

Fig.15 Structure of Japanese economy in 1975.

## 6.7 Visual Q-analysis [14,16,23,29,30]

A novel method called Visual Q-Analysis(VQA) was proposed to analyze structures of complex systems. This method is based upon Q-analysis(Atkin 1977) where the structure of a system is represented by simplicial complex in topology and analyzed in terms of q-connectivity.

Two different types of hierarchies, Q-hierarchy and F-hierarchy, are introduced and algorithms to obtain these are given. In order to draw these hierarchies in a visually understandable form SKETCH system developed are used. The Q-hierarchy visualizes a hierarchical q-connectivity structure among all the simplices and the F-hierarchy expresses a structure of face-sharing among the simplices in the complex. By inspecting their drawings we can grasp the structural information embeded in the complex.

This method is applied to a structural study of technological development of future computers of Japan in terms of relationships between social needs and technological requirements(seeds). Results of the application not only show the effectiveness of VQA to support in planning technological developments but also suggest wide applicablities of VQA to various other fields. A result has been reported as IIASA collaborative paper[14].

Appendix : Bibliography of SKETCH system

- [1] Kitagawa, T. and K. Sugiyama (1978): A informative method for recognizing the research trend, Proceedings of the 19th Conference of Information Processing Society of Japan, pp.863-864. (in Japanese)
- [2] Kitagawa, T., K. Sugiyama, S. Tagawa and M. Toda (1979): Machine drawing of diagrams of citations among scientific literatures, Proceedings of the 20th Conference of Information Processing Society of Japan, pp.781-782. (in Japanese)
- [3] Sugiyama, K., T. Hiramatsu and Y. Shimazu (1978): Toward development of earthquake disaster relational model, Proceedings of International Conference on Cybernetics and society, Nov. 1978, Tokyo and Kyoto, pp.788-793.
- [4] Sugiyama, K., S. Tagawa and M. Toda (1979a): A method for reducing the number of crossings in a multilevel digraph (Barycentric method), Technical Report of the Institute of Electronics and Communication Engineers of Japan, vol.78, no.247, EC78-61, pp.1-21. (in Japanese)
- [5] Sugiyama, K., S. Tagawa and M. Toda (1979b): A method for the visualization of a multilevel digraph, Proceedings of the 1979 Conference of the Institute of Electronics and Communication Engineers of Japan, p.1507. (in Japanese)
- [6] Sugiyama, K., S. Tagawa and M. Toda (1979c): A method for the two-dimensional drawing of a multilevel digraph: A vertex-layout method after reducing the number of crossings, Proceedings of the 5th System Symposium of the Society of Instrument and Control Engineers, pp.199-204. (in Japanese)
- [7] Sugiyama, K., S. Tagawa and M. Toda (1979d): Representations of system structures by a multilevel digraph I: Scheme and applications, Proceedings of the 18th Conference of the Society of Instrument and Control Engineers, pp.97-98. (in Japanese)
- [8] Sugiyama, K., S. Tagawa and M. Toda (1979e): Effective representations of hierarchical structures, Research Rep. no.8,

- International Institute for Advanced Study of Social Information Science (IIAS-SIS), Fujitsu Ltd., 29p.
- [9] Sugiyama, K., S. Tagawa and M. Toda (1979f): Effective representations of ISM hierarchies, Proceedings of International Conference on Cybernetics and Society, Oct. 1979, Denver, pp.413-418.
  - [10] Sugiyama, K., S. Tagawa and M. Toda (1980a): Effective representations of the citation structures in large-scale computer programs, Brainware B1-246, IIAS-SIS, Fujitsu Ltd. (in Japanese)
  - [11] Sugiyama, K., S. Tagawa and M. Toda (1980b): A conversion method of ISM digraph: Conversion of connected multilevel digraphs into tightly connected multilevel digraphs, Proceedings of the 24th Conference on System and Control, pp.27-28. (in Japanese)
  - [12] Sugiyama, K., S. Tagawa and M. Toda (1981a): Methods for visual understanding of hierarchical system structures, IEEE Trans. SMC, vol.SMC-11, no.2, pp.109-125.
  - [13] Sugiyama, K., S. Tagawa and M. Toda (1981b): Visual representations of structural information: Algorithms for automatic drawing of hierarchical structures and its applications, Japanese Report no.2, IIAS-SIS, Fujitsu Ltd., 41p. (in Japanese)
  - [14] Sugiyama, K. and M. Toda (1982): Visual Q-analysis: A case study of future computer system developments, IIASA Collaborative Paper CP-82-51, 36p.
  - [15] Sugiyama, K., M. Toda and S. Tagawa (1979): Effective layout and automatic drawing of ISM digraphs, Proceedings of the 23rd Conference on System and Control, pp.77-78. (in Japanese)
  - [16] Sugiyama, K., M. Toda and S. Tagawa (1980): Two-dimensional drawing and understanding of structural models, Proceedings of the 6th System Symposium of the Society of Instrument and Control Engineers, pp.173-178. (in Japanese)
  - [17] Sugiyama, K., M. Toda and S. Tagawa (1981): Visual Q-analysis and its application to a structural study of technology innovations, Research Rep. no.19, IIAS-SIS, Fujitsu Ltd., 28p.
  - [18] Tagawa, S., M. Toda and K. Sugiyama (1979a): Representation of

system structures by a multilevel digraph II: Mathematical formulation, Proceedings of the 18th Conference of the Society of Instrument and Control Engineers, pp.99-100. (in Japanese)

- [19] Tagawa,S.,M.Toda and K.Sugiyama (1979b): On a penalty minimization method in multilevel digraphs, Proceedings of the Conference of the Society of Mathematics of Japan, pp.239-241. (in Japanese)
- [20] Tagawa,S.,M.Toda and K.Sugiyama (1980a): On an algorithm for solving minimum feedback ark set problems, Proceedings of the Conference of the Society of Mathematics of Japan, pp. 64-68. (in Japanese)
- [21] Tagawa,S.,M.Toda and K.Sugiyama (1980b): On an optimization method for reducing the number of crossings in multilevel digraphs, Proceedings of the Autom Conference of the Society of Operations Research of Japan, pp.46-47. (in Japanese)
- [22] Tagawa,S.,M.Toda and K.Sugiyama (1981): Optimization methods for reducing the number of crossings in multilevel digraphs, Research Rep. no.12, IIAS-SIS, Fujitsu Ltd., pp.1-20.
- [23] Toda,M. (1982): A method based on structural analysis for evaluating strategies of technological developments, Research Rep. no.31, IIAS-SIS,Fujitsu Ltd.,26p.
- [24] Toda,M. and K.Sugiyama (1982): A structural study of the planning of integration-typed technological developments: A case study on the fifth generation computer systems development, Proceedings of the 11st Symposium on Technology Assessment, (in Japanese)
- [25] Toda,M.,K.Sugiyama and S.Tagawa (1979a): Hierarchization of system structures based on a majority decision rule, Proceedings of the 5th System Symposium of the Society of Instrument and Control Engineers, pp.277-282. (in Japanese)
- [26] Toda,M.,K.Sugiyama and S.Tagawa (1979b): Representations of system structures by a multilevel digraph III: Practical methods, Proceedings of the 18th Conference of the Society of Instrument and Control Engineers,pp.101-102. (in Japanese)
- [27] Toda,M.,K.Sugiyama and S.Tagawa (1979c): Hierarchization of system strucrues based on multivalued relations and its effective representation, Proceedings of the 1980 Conference



of the Society of Electronics of Japan, pp.1662-1663. (in Japanese)

- [28] Toda, M., K. Sugiyama and S. Tagawa (1980a): An ordering method for collective preference based on a majority decision rule, Research Rep. no.10, IIAS-SIS, Fujitsu Ltd.
- [29] Toda, M., K. Sugiyama and S. Tagawa (1980b): An ordering method for collective preference based on a majority decision rule, Proceedings of the International Conference on Cybernetics and Society, Oct.1980, Cambridge, pp.242-247.
- [30] Toda, M., K. Sugiyama and S. Tagawa (1981): An application of visual Q-analysis to the integration-typed technological developments and methods for representing the results, Proceedings of the 21st conference of the Society of Instrument and Control Engineers, pp.73-74. (in Japanese)

REFERENCES

- Atkin,R.II. (1977) : Combinatorial connectivities in social systems, Birkhauser, Basel.
- Casti,J. (1979): Connectivity, complexity and catastrophe in large scale systems, International Series on Applied Systems Analysis, Wiley.
- Elmaghraby,S.E. (1977): Activity networks: Project planning and control by network models, Wiley.
- Forrester,J.W. (1971): World dynamics, Wright-Allen Press.
- Lempel,A. and Cederbaum,I. (1966): Minimum feedback arc and vertex sets of a directed graph, IEEE Trans. CT, vol.CT-13,no.4, pp. 339-403.
- Warfield,J.N. (1974): Toward interpretation of complex structural models, IEEE Trans. SMC,vol.SMC-4,no.5, pp.405-417.
- Warfield,J.N. (1976): Societal systems; Planning, policy and complexity, Wiley.
- Warfield,J.N. (1977): Crossing theory and hierarchy mapping, IEEE Trans. SMC, vol.SMC-7, no.7, pp.505-523.