

NOT FOR QUOTATION
WITHOUT PERMISSION
OF THE AUTHOR

INFORMATION SYSTEMS FOR
MULTIREGIONAL PLANNING

Peter Nijkamp*

May 1982
CP-82-27

*The Free University
Amsterdam,
The Netherlands

Collaborative Papers report work which has not been performed solely at the International Institute for Applied Systems Analysis and which has received only limited review. Views or opinions expressed herein do not necessarily represent those of the Institute, its National Member Organizations, or other organizations supporting the work.

INTERNATIONAL INSTITUTE FOR APPLIED SYSTEMS ANALYSIS
A-2361 Laxenburg, Austria



PREFACE

This paper is the first of a set of background papers and research papers on information systems for regional planning. Information systems contain structured data on real-world phenomena, their properties, and their mutual links.

Frequently, however, information systems are oriented to the national level or to specific factors. The geographical dimension of information systems as a decision aid in regional development planning has too often been neglected. Therefore, much more attention should be paid to the design and development of information systems reflecting socio-economic processes so as to arrive at a better representation of regional systems and a better adaptation to the needs of regional planners.

The major aim of the current study is to provide in a systematic way a set of guidelines and considerations to be taken into account in the design and use of information systems for regional planning. In addition to the conceptual framework, regional accounting, integrated statistical information systems, regional modeling, and qualitative information may also be addressed in this study.

The present paper written by Peter Nijkamp (Free University, Amsterdam) outlines some important aspects and attributes of information systems for multiregional planning. It provides a frame of reference for more specific contributions to information systems for particular regional planning fields.

March 1982

Boris Issaev
Leader
Regional Development
Group



INFORMATION SYSTEMS FOR MULTIREGIONAL PLANNING

Peter Nijkamp*

1. INTRODUCTION

During the post-war period, almost all countries of the world experienced an information explosion. The introduction of computers, micro-electronic equipment and telecommunication services almost caused an avalanche of information, not only for scientific research, but also for information transfer to a broader public and for planning or policy purposes (see also Burch et al. 1979).

The complexity of modern societies and the enormous costs of taking wrong decisions have led to a general need for appropriate information, not only at the level of individual decision making but also at the level of social and economic organizations (cf. Sowell 1980). The data storage capacity of modern computers favors also a much more structured use of information than in previous periods.** Not only in the developed world, but also

* The author thanks Edwin Hinloopen, Boris Issaev, and Piet Rietveld for their comments on a first draft of this paper.

** Here a distinction is made between data and information. Data are numerical representations or other symbolic surrogates aiming at characterizing attributes of people, organizations, objects, events, or concepts. Information means data structured (by way of modeling, organizing, or converting data) so as to increase the insight or level of knowledge regarding a certain phenomenon.

in developing countries, proper and systematic information is regarded as a prerequisite for successful planning (cf. also Casley and Lury 1981).

Clearly, there are many trade-offs involved in collecting data and developing information systems. The accuracy, adaptability and timely availability have to be traded off against the economic consequences in terms of costs and benefits. A necessary condition for a manageable information level is a permanent user-surveyor dialogue so as to guarantee a meaningful coordination of the various tasks in a planning process.

A basic element of a meaningful information system is also the assessment of uncertainties or risks regarding the outcomes of certain selected alternatives.* This also implies a certain trade-off, since the probability of occurrence of a successful decision has to be judged against the anticipated net benefits of this decision (see Figure 1). In a formal sense the probability of success of a certain decision can also be approximated by means of the (reverse) variance of a probability density function for the outcomes of a decision.

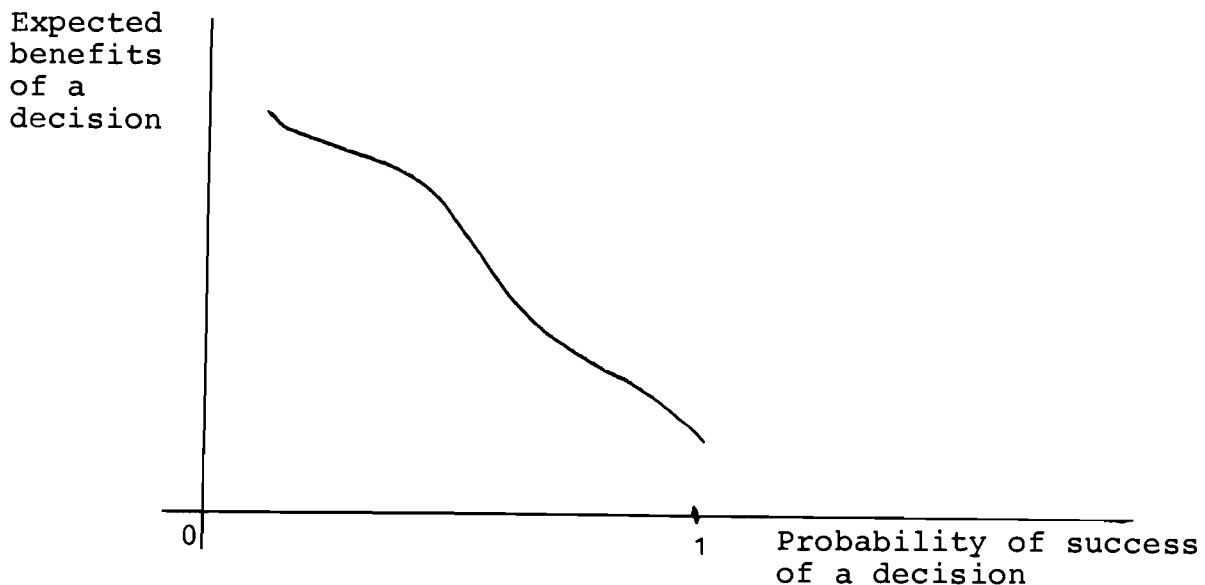

Figure 1. Revenue curve as a function of probability of success.

* A risk situation implies that the probability density function of the outcome of a decision is known, while uncertainty means lack of knowledge regarding a probability density function.

It is clear that decisions with a higher uncertainty or risk will only be taken if they are compensated for by higher benefits. Consequently, risk and uncertainty analysis may also be an important component of an information system.

In general, one may state that the provision of information may have two consequences:

- the expectation of the outcomes of a decision (i.e., the anticipated benefits) and the variance of these events (i.e., the probability of failure) can be more precisely assessed;
- in the course of time, the expectation may be increased and the variance decreased.

The latter observation is in agreement with the view of Braybrooke and Lindblom (1979) who have investigated the relationship between the impact (or depth) of a certain decision and the required information level (or level of knowledge). In line with their conclusions, we may draw Figure 2.

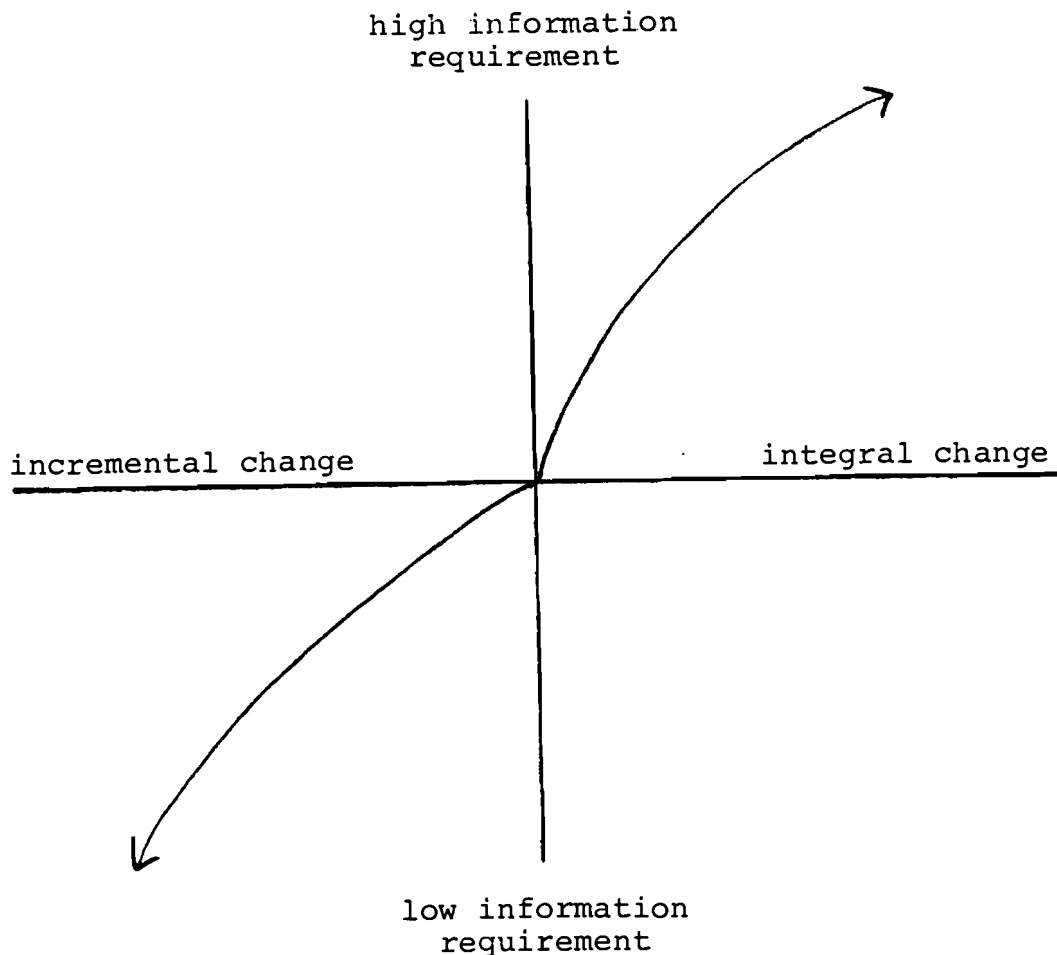

Figure 2. Relationship between information requirement and impact of a decision.

Consequently, the basic problem of dealing with information systems is a trade-off between the costs of producing relevant information from appropriate data and the benefits of employing this information in actual planning procedures or policy decisions. Before we can analyze this question in greater detail, it is necessary to pay attention to the nature of appropriate data, the way of producing information and the way of treating information in actual choice situations. This will be done in subsequent sections.

2. THE NATURE OF DATA

Data can be collected at various levels and from various viewpoints. From an ideal point of view, the nature of data is determined by the aims of the analysis (impact analysis, plan evaluation, e.g.), but in reality one very often has to use an existing and given data base in the most efficient way so as to extract the most relevant information for a prespecified use in a planning context. For instance, it appeared from the international survey of multiregional economic models (carried out by the Regional Development Group of the International Institute for Applied Systems Analysis; see Issaev et al., 1982), that the majority of multiregional economic models did not have their own specific data base, but employed the existing data provided by various statistical offices.

In general, data can be measured on different scales (cf. Harvey, 1969). Two major measurement scales are the qualitative and the quantitative scale.

The qualitative scale can be subdivided into a nominal scale and an ordinal scale:

- nominal: a classification into distinct groups (green or red, e.g.) or into distinct size classes (small impacts or large impacts, e.g.); a binary system also belongs to this class.

- ordinal: a ranking of events or effects in order of magnitude (for instance, 1,2,3,4,...); a difference between ordinal figures does not have any numerical meaning.

The quantitative (or ordinal) scale can be subdivided into an interval and ratio scale:

- interval: a measurement system which allows a calculation of (Euclidean) distances between figures, though the figures themselves have only a relative meaning.
- ratio: a measurement system in which figures have an absolute numerical meaning, so that they can be represented in a normal Euclidean system.

In the past, the majority of concepts, variables and attributes in the social sciences has been defined on a quantitative scale according to a natural science approach, but recently much effort has been put into the development of qualitative (or soft) data methods in the social sciences. Examples can be found in Brouwer and Nijkamp (1982), Nijkamp and Rietveld (1982a) and Wrigley (1980). Non-parametric statistical tools (such as rank correlation methods), multidimensional and homogeneous scaling methods, log-linear analysis, logit and probit analysis, contingency table analysis, and latent variables methods have provided many contributions to a valid quantitative treatment of qualitative data. Similar developments can be found in plan evaluation methods (cf. Nijkamp 1980, Rietveld 1980, and Voogd 1982).

The production of data is a problem in itself. Normally data are collected from a multi-purpose point of view, so that it is usually very difficult to obtain data with a precise and distinct focus on the problem at hand. Very often, data have to be manipulated, (dis)aggregated or adjusted in order to fit into a precisely demarcated research or planning problem (cf. also Langefors 1966).

Data can be collected at various levels of aggregation, for instance at individual levels (individual household income, e.g.) or at aggregate levels (average regional income, e.g.). Such data may be the results of interviews, questionnaires, censuses, samples, survey or non-survey techniques. The choice for a specific data collection technique and for the level of aggregation of these data will be determined by the aim of the information system and will also depend on the abovementioned trade-off between costs and expected usefulness (cf. Park et al. 1981). The loss of information due to an aggregate representation of disaggregate variables can be represented by the entropy measure: entropy measures the ignorance of micro-variables when one knows only a macroscopic variable (see Gokhale and Kullback 1978).

A basic problem is of course that one is usually not only interested in measures describing the state of a system, but also its evolution. Up-to-date data for complex systems, however, are normally hard to obtain because of the high costs of a permanent filing system for relevant data. Sometimes interpolation or extrapolation techniques are used to cope with the lack of data for a time series. Other common techniques for updating data sets are RAS-techniques (for input-output tables) or entropy techniques (for spatial interaction data). Needless to say that none of these techniques will be able to reflect sudden jumps or shifts in a system.

3. THE PRODUCTION OF INFORMATION

As mentioned before, a restructuring and interpretation of data is a way of generating information. This treatment of data may be based on various aspirations (cf. also Burch et al. 1979). Examples of such operations are:

- capturing: a systematic recording of data,
- verifying: validating the correct nature of data,
- classifying: grouping data into specific classes,
- arranging: placing data in a predetermined sequence,
- summarizing: aggregating data into new sets,
- calculating: manipulating data in an arithmetic way,

- forecasting: extrapolating data toward the future,
- simulating: assessing and manipulating lacking data,
- storing: placing data onto storage media,
- retrieving: selecting specific data from specific media,
- communicating: transferring data to other users.

All these operations are determined by the aims of the information system at hand. The choice for certain operations very much depends on the related costs caused inter alia by the personnel requirement, the modularity, flexibility and versatility of the system concerned, and the processing speed and control.

The benefits of an information system depend inter alia on its accessibility, comprehensiveness, accuracy, appropriateness, timeliness, clarity, flexibility, verifiability, freedom from bias, and quantifiability.

Clearly, a system with redundant information may lead to inefficient decisions, while lack of information may also lead to less than optimal decisions. Theoretically, an optimum level of information will be reached, if the marginal value of information equals its marginal cost. In reality, these costs and benefits can hardly be expressed by one common denominator, so that this marginality rule has only a limited practical relevance. The various aspects involved in judging the value of an information system normally requires a multidimensional trade-off.

4. THE USE OF INFORMATION

Information as structured data systems can be used in three stages of a planning process viz. description, impact analysis, and evaluation. These three elements will now successively be discussed.

4.1. Description

A description means a structural representation of the data regarding a system. For instance, the social indicator movement may be regarded as an attempt at representing relevant features of a social system in a systematic way. The same holds true for environmental quality analysis.

In general, it appears to be meaningful to represent the main characteristics of a system by means of multidimensional profiles (Nijkamp 1979). Each of these profiles comprises a set of relevant indicators. For instance, a regional system may be characterized by means of the following profiles:

- economic: production
 investments
 labor market
 consumption, etc.
- housing: quantity of dwellings
 quality of dwellings
 residential climate
 prices and rents, etc.
- infrastructure: accessibility (public and private
 transport)
 distance
 mobility (migration, recreation), etc.
- finances: taxes
 subsidies
 public expenditures
 distributional aspects, etc.
- facilities: health care
 cultural
 social
 recreational, etc.
- environmental: air pollution
 noise
 sewage systems
 congestion
 segregation
 density, etc.
- energy: energy consumption
 insulation of dwellings
 central urban heating system
 tariff system, etc.

Depending on the aim of a specific descriptive analysis, a choice among the foregoing profiles (including their levels of measurement) has to be made in order to get an integrated view of the system at hand. Thus, such a descriptive view implies a transformation of data into structured information classes.

Such profiles with detailed elements are not only relevant in regional economics but also in many other disciplines such as environmental science, geography, and demography. In all these disciplines there is a basic need for a systematic storage and treatment of relevant data (cf. Blitzer et al. 1975, Hordijk et al. 1980, Rees and Willekens 1981).

4.2. Impact Analysis

In the last decade several types of impact analysis for planning and policy purposes have been developed: environmental impact analysis, social impact analysis, input-output analysis, technological impact analysis, urban impact analysis, and so on. The main aim of impact analyses was to get a more complete, systematic, and comprehensive information on the effects of public policy decisions or of exogenous shifts in the parameters or data of a system. Impact analysis will be defined here as a method for assessing the foreseeable and expected consequences of a change in one or more exogenous stimuli that exert effects on the element of the profiles characterizing a system (see Nijkamp 1982 and Pleeter 1980). In general, impact analysis implies a transformation of first-order information into new information categories.

The need for impact analysis stems from various sources:

- a systematic inventory of consequences of public policy may lead to more justified policy decisions;
- an integrated impact analysis may avoid neglect of (potentially important) indirect or unintended effects;
- the presence of spillover effects and interactions between several compartments of a system requires a comprehensive view of its complicated mechanism;

- the hierarchical structure of many planning systems evokes the need for a multi-level impact analysis which is able to trace all relevant consequences at various levels.

Due to the pluriformity and complexity of western industrialized countries, coherent, and balanced public policy strategies are usually fraught with difficulties. For instance, the integration and co-ordination of various aspects of physical-economic planning problems (such as public facilities, communication and infrastructure networks, residential housing programs, industrialization programs, etc.) are often hampered by administrative frictions, mono-disciplinary approaches, lack of information and political discrepancies.

An impact analysis may be a meaningful tool for more integrated and co-ordinated planning strategies, since such analysis describes systematically the effects of changes in control variables on all other components of a system. Consequently, an impact analysis should pay attention to the variety, coherence, and institutional framework of the system at hand. This implies that economic, spatial, social, and environmental variables should be included as relevant components of the system. Preferably, an impact analysis should be based on a formal model (see also Glickman 1980 and Snickars 1982).

The grouping of a variety of variables in an impact analysis may be based on similarities in effects (cf. Friedrich and Wonne-mann 1981). Examples of such effects are: changes in spatial accessibility, changes in urban residential climate, changes in social structures, changes in urban employment attractiveness, etc. Such responses may emerge from several stimuli (changes in control variables), such as: urban housing programs, energy conservation programs, construction of an infrastructure network, etc.

Formally, the relationships between policy controls and the related impacts may be represented by a (qualitative and quantitative) model that reflects the structure of the system at hand.

In this way, also indirect and multiplier effects can be taken into account (cf. Neshar and Schinnar 1981). Such models can be used for forecasting and simulation purposes.

Given the pluriformity and variety among the elements of most social systems, the above-mentioned multidimensional profile approach is often a meaningful analytical method for considering systematically a wide variety of different aspects in such systems.

Any information system may be extended with a scenario analysis. A scenario analysis serves to investigate the impacts of (hypothetical) policy measures, so that these impacts can be confronted with (or judged on the basis of) a reference profile (e.g., a target profile) arising from policy targets or general objectives. Figure 3 may clarify the preceding remarks.

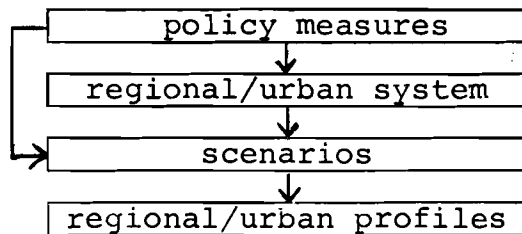

Figure 3. States of a regional/urban scenario analysis.

Sometimes it may be useful to employ an impact structure matrix which reflects the effects of policy controls (p_1, \dots, p_N) upon the systems components (c_1, \dots, c_I) (see Figure 4).

controls \ impacts	c_1, \dots, c_I
p_1	
.	
.	
.	
p_N	

Figure 4. An impact structure matrix.

An illustrative example of a spatial interaction system which might provide the information necessary to fill in the impact structure matrix is contained in Figure 5.

It has to be added that the dynamics in such a (spatial) impact system may be the result of several forces: (1) autonomous developments (e.g. capital formation), (2) exogenous developments (e.g. rise in oil prices), and (3) policy measures (at either the systems level or the supra-systems level).

4.3. Evaluation

Evaluation refers to the process of analyzing plans, proposals, or projects with a view to searching for their comparative advantages and disadvantages and the act of setting down the findings of such analyses in a logical framework. Thus, the essence of evaluation in a planning context is the assessment of the comparative merits of different courses of action, so as to assist the process of decision-making (see Lichfield et al. 1975). Necessary steps prior to the evaluation process itself are the descriptive analysis and the impact analyses set out above. Evaluation essentially implies a confrontation of structured information categories with policy and planning views.

Evaluation may take various forms: social cost-benefit analysis, cost-effectiveness analysis, planning balance sheet analysis, multiple criteria analysis, linear programming analysis, multi-objective programming analysis, and so forth. Especially during the seventies, a whole spectrum of operational evaluation methods has been developed to assess the pros and cons of effects of various courses of action (see for a survey also Nijkamp 1979).

Evaluation requires the definition of a set of operational judgement criteria (efficiency criteria, equity criteria, environmental criteria, etc.), a set of alternative actions or strategies (including information on their technical and economic feasibility), a set of (implicit or explicit) preference parameters reflecting the relative importance attached to certain outcomes of a given action or strategy. Sometimes scenario analyses are also used as a way of dealing with hypothetical reasonable policy preference patterns.

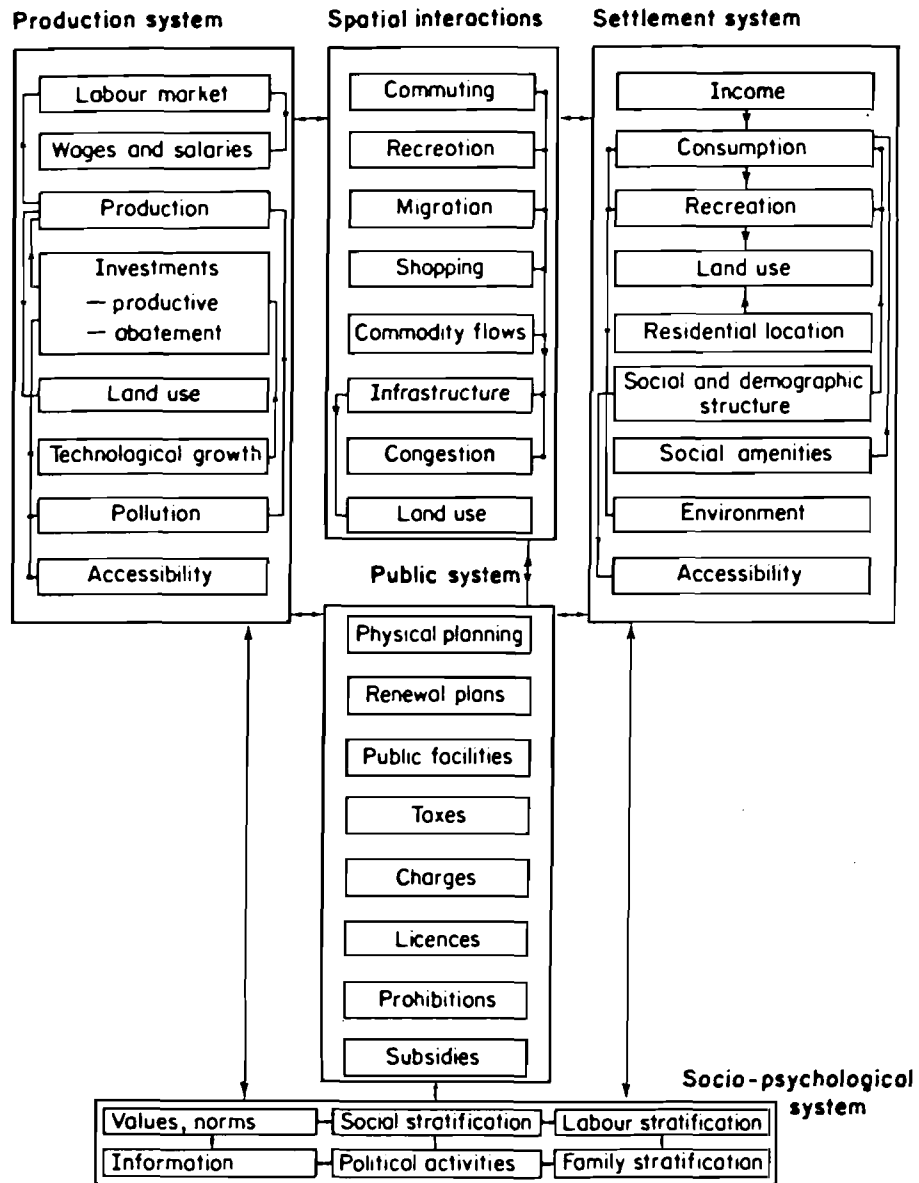

Figure 5. An illustrative spatial interaction system.
Source: Nijkamp 1979.

It should also be noticed that planning is essentially a process, so that during each stage the necessary and relevant information has to be provided. A good example of a survey of stages in a planning process can be found in Lichfield et al. (1975) (see Figure 6).

In order to make full use of information in evaluation and decision-making, it is also necessary to indicate precisely the nature of the variables included (target variables, instruments, exogenous data). This has to be done for each profile mentioned in sub-section 4.1. In general, it is also useful to indicate precisely how a certain desired end-result should be reached (cf. the well-known golden-section and turnpike rules). In order to prevent decision-makers from taking infeasible courses of action, threshold analysis and bottleneck analysis may provide useful information about the conditions under which a certain new state of the system might evolve.

5. A SYSTEMS VIEW OF PLANNING

Since planning is a complex and multi-stage activity, it is extremely important to obtain a distinct focus from a synthesizing viewpoint. In this respect, a systems approach may be extremely valuable (see also Chadwick 1971), for this may offer a comprehensive picture of all information requirements. In general, a systems approach aims at portraying the processes and relationships in a complex system that encompasses various components, which are linked together by means of functional, technical, institutional, or behavioral linkages, and which can also be influenced by changes in parameters or controls from the environment outside the system itself.

Then a formal systems representation of an information system can be given as follows. The set of profiles characterizing the successive parts of the system concerned is denoted by $P = \{p_1, \dots, p_N\}$, while the set of attributes of each profile n ($n = 1, \dots, N$) is denoted by $A_n = \{a_{n1}, \dots, a_{nI}\}$. The compound representation of all attributes over all profiles may thus be represented as a set $A = \{A_1, \dots, A_N\}$.

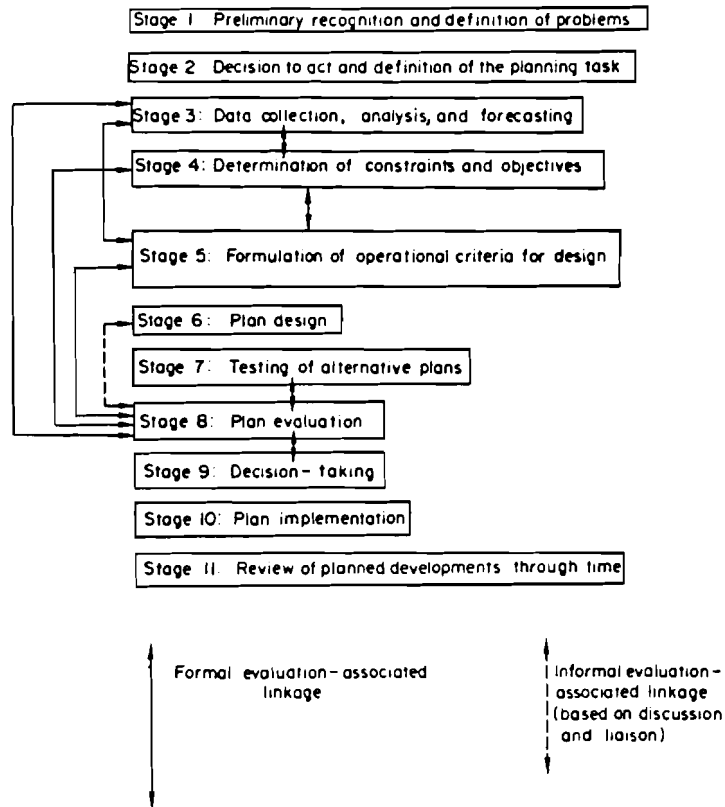

Figure 6. Linkages between stages in the planning process.
Source: Lichfield et al. 1975, p. 40.

We may also introduce a set of exogenous policy fields E_1, \dots, E_J , which constitute part of the environment of the above-mentioned system. The specific policy measures associated with each policy field j ($j = 1, \dots, J$) can be included in a set $B_j = \{b_{j1}, \dots, b_{jM}\}$; the compound representation of all b_j 's is represented as $B = \{b_1, \dots, b_J\}$. Thus the components of the system are denoted by $\{A, B\}$.

The interactions and relationships can be dealt with in a similar manner. Let $s_{ni}^{n'i'}$ represent the relationship between any element a_{ni} and $a_{n'i'}$, within the system at hand, then the set of internal relationships within this system can briefly be represented as $S = \{s_{ni}^{n'i'} ; \forall n, n', i, i'\}$. Let r_{ni}^{jm} represent the relationship between any element a_{ni} within the system and any element b_{jm} outside the system, then the impact relationships from (external) policies upon the elements of the (endogenous) profiles can be denoted as $R = \{r_{ni}^{jm} ; \forall n, i, j, m\}$. Then the following compound representation of an information system U can be given: $U = \{A, B, S, R\}$. The latter expression can be seen as a formal definition of an information system. The set of relationships and interactions S and R may include all kinds of relations: series, parallel, feedback, and compound relations.

In an illustrative way the functioning of such a system can now be represented as follows (see Figure 7).

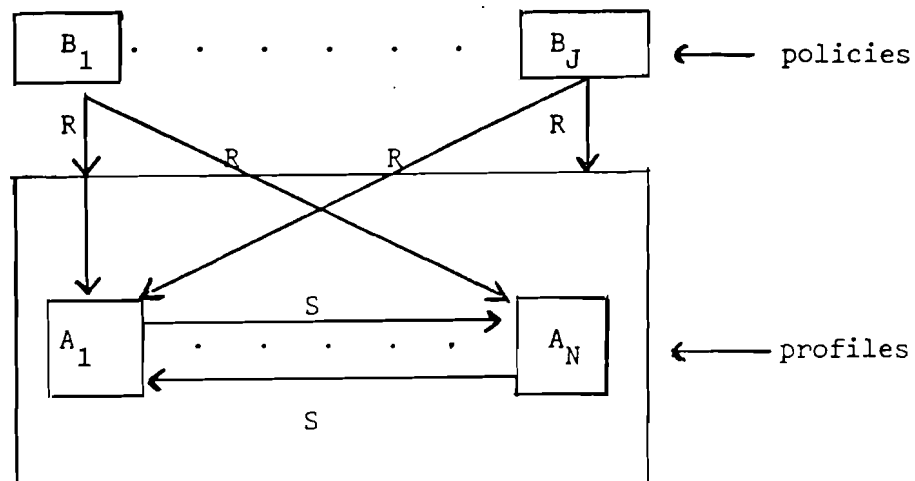

Figure 7. Simple representation of an information system.

The foregoing systems approach gives a systematic representation of the state of a system. Clearly, more complicated systems with multiple components, multiple policy levels, and interactions between policy fields (or profiles) can be treated in an analogous way.

It is evident that such an information system requires data on the set of relationships S and R , and on the sets A and B as well. These relationships might be represented by means of a formal econometric model (estimated by means of time-series or cross-section data) or by means of graphs or arrows. The latter approach is more modest, since it does not require the construction of a comprehensive econometric model; in this case, however, frequently only qualitative statements regarding the responses of the system to policy measures can be made.

6. INFORMATION SYSTEMS FOR MULTIREGIONAL DEVELOPMENT PLANNING

The abovementioned expositions on information systems are fairly general and do not have a distinct focus on a given problem area. Therefore, it may be worthwhile to delimitate the scope of the present paper by addressing problems of information systems in a multiregional development setting so as to pay more attention to the use of such systems in regional planning.

Therefore, the following specific approach to multiregional information systems (MIS) approach will be adopted:

- the analysis will be based on a systems approach of information for regional development;
- the analysis will only focus on systems with multiple regions;
- the analysis will only analyze information systems, insofar as they are developed for regional planning purposes;
- the analysis will particularly address modeling efforts as part of the planning process;
- the analysis will focus on those aspects which will allow a generalization by means of an international comparative study;
- the analysis should be focused (after a general overview of problems) on a specific problem area or a limited set of problem areas; and

- the analysis should lead to research recommendations and policy conclusions for information systems for regional planning in various national systems.

Given the abovementioned features of a meaningful study on information systems for regional planning models, it may be worthwhile to specify some general judgement criteria for such information systems. The following considerations may be mentioned:

- availability of information: the relevant information should be available during the successive stages of the planning process so as to guarantee an adequate picture of the system at hand (including possibly longitudinal data);
- actuality of information: the information should be based on recent data in order to provide a representative and up-to-date picture of a complex reality;
- accessibility: the information should be accessible to both model builders and users (including policy makers and planners);
- consistency: the information should represent a set of coherent and non-contradictory data on regional processes and patterns;
- completeness: the information should take into account all (intended and unintended) effects and implications of policies upon the system at hand;
- relevance: the information produced should be in agreement with the aims of regional (or urban) management and planning;
- pluriformity: the variables included in an information system should reflect the variety and multidimensionality of a multiregional system;
- comparability: the various data included in an information system should allow a comparison with other data measured at different time periods or in different areas;
- flexibility: the information system should provide comprehensive information which can be adjusted to the needs of users or to new circumstances;

- measurability: the information system should take into account the available data measured on any meaningful scale (including qualitative information);
- comprehensiveness: the various components of an information system should provide an integrated picture of a multiregional system;
- effectiveness: the information produced should allow a confrontation with a priori set policy targets, so that the effectiveness of policy measures can be gauged;
- versatility: the information provided may also be used for other planning purposes;
- validity: the reliability of the information provided and of the related statistical inferences should allow a judgement to be made from a statistical or econometric point of view.

In addition to these general methodological criteria, some specific regional or multiregional elements of a MIS can also be mentioned (see also Bowman and Kutscher 1980; Garnick 1980; Torene and Goettee 1980):

- integration: the information system should attempt to present relevant data for each relevant spatial level and each relevant spatial unit, so as to guarantee both a comparability of data from one region to another and a coordination of various planning activities in different agencies;
- interregional interaction: a MIS should reflect the interlinkages within a spatial system by demonstrating the volumes of interregional commodity flows, migration flows, capital flows, etc.;
- specific regional bottlenecks: an information system should also indicate whether or why important regional information is lacking (for instance, the frequent lack of insight into monetary flows between regions);
- multiregional decision-making: various decisions affecting a regional economy are made in headquarters of corporate decision-making bodies; in addition, flows of

income and profits are hard to attribute to a specific region. A MIS should try to disentangle the complexity of such a spatial system.

- standardization: in order to make data comparable across regions, they have to be standardized (for instance, by relating them to the population size or the size of the area). An information system should provide a sound basis for such a standardization and should also indicate the sensitivity of the results for a specific standardization (depending inter alia on the social and demographic structure).

Many countries have developed a MIS for regional development planning, though there is also an enormous variation among information systems in various countries. A good example of an integrated MIS can be found in the USSR planning system (see Issaev 1982). A condensed representation of a combined multi-sector, multiregion planning system is contained in Figure 8 which gives the general configuration of the so-called SMOTR model (see Baranov and Matlin 1982). A MIS should provide the basic information for such a planning system.

Other good examples of regional and urban information systems can be found among others in Hågerstrand and Kuklinski 1971, Kuklinski 1974, Perrin 1975, Benjamin 1976, Guesnier 1978, and Elfick 1979. In an interesting survey article, Hermansen (1971), has given an appropriate and fairly complete representation of an information system for regional development planning (see Figure 9).

7. RESEARCH PROBLEMS FOR MULTIREGIONAL INFORMATION SYSTEMS

Planning activities may take place at several levels each interacting with the others. Figure 10 indicates that an integrated planning system may combine a bottom-up and a top-down structure. This structure is determined by functional economic relationships (for instance, those included in a formal econometric model) and the prevailing institutional structure.

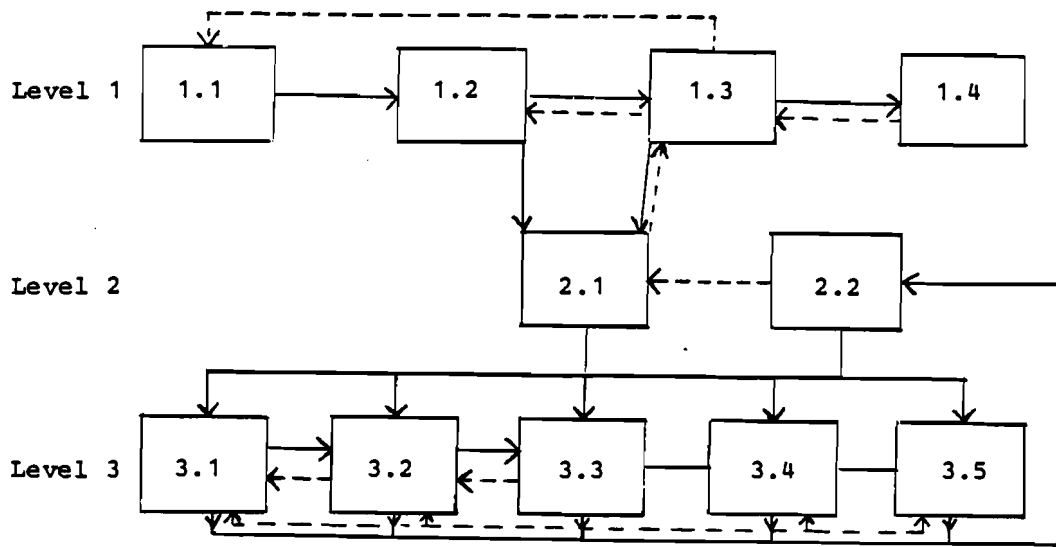

- 1.1. Overall macro-economic indicators
- 1.2. Goal indicators for national economic development
- 1.3. Simulation dynamic input-output model 18 x 18
- 1.4. Interindustry flows model based on sectoral production functions

- 2.1. Dynamic model based on integrated products value flows interindustry balance (260 products)
- 2.2. "Center" model

- 3.1. Models of separate industries and industrial complexes
- 3.2. Model for building and construction of industrial complex
- 3.3. Module of regional models
- 3.4. Module of transportation complex
- 3.5. Models of supply with intermediate goods

Figure 8. General configuration of SMOTR. Source: Baranov and Matlin 1982.

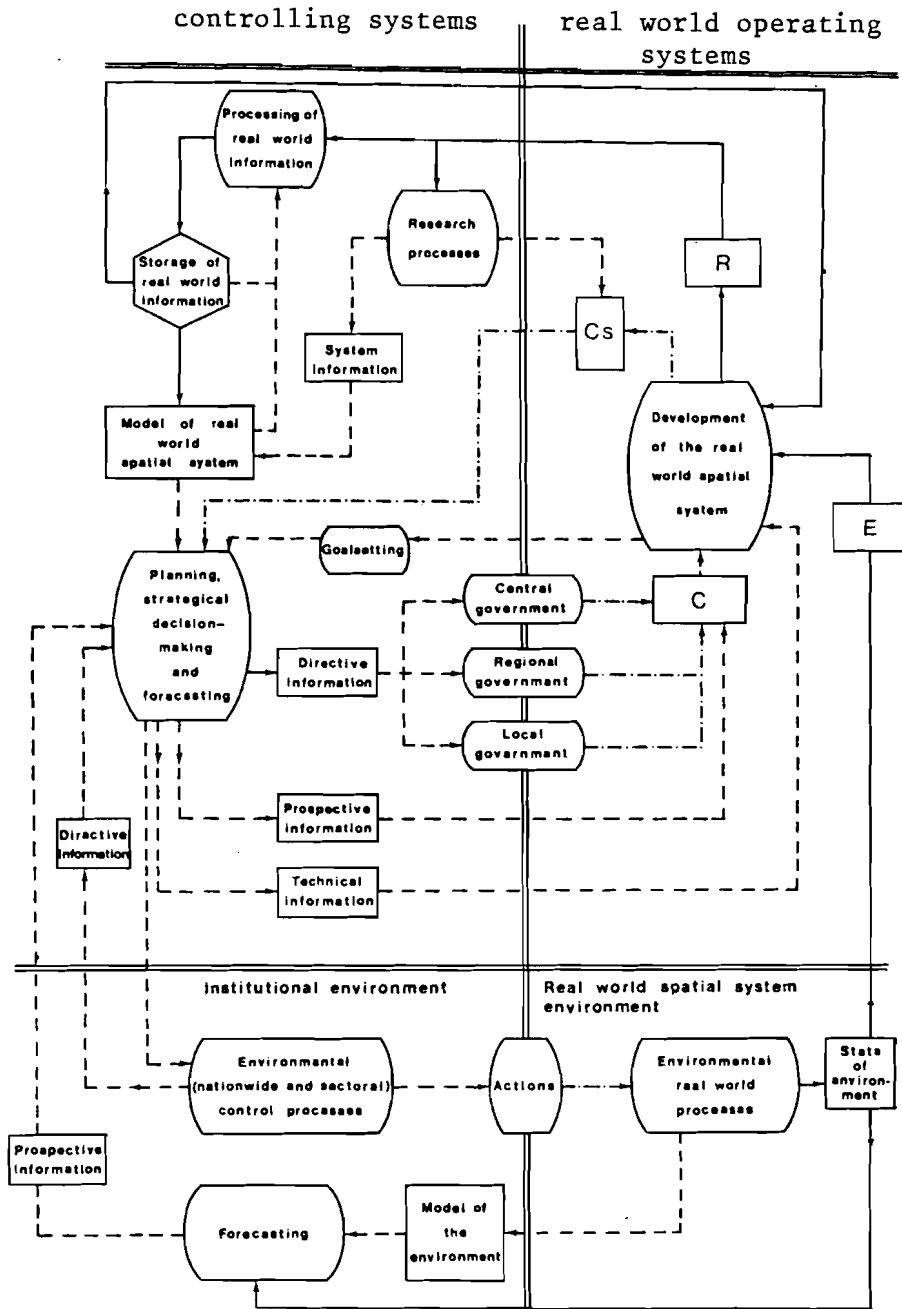

Figure 9. A comprehensive information system for regional development planning. Source: Hermansen 1971, p. 31.

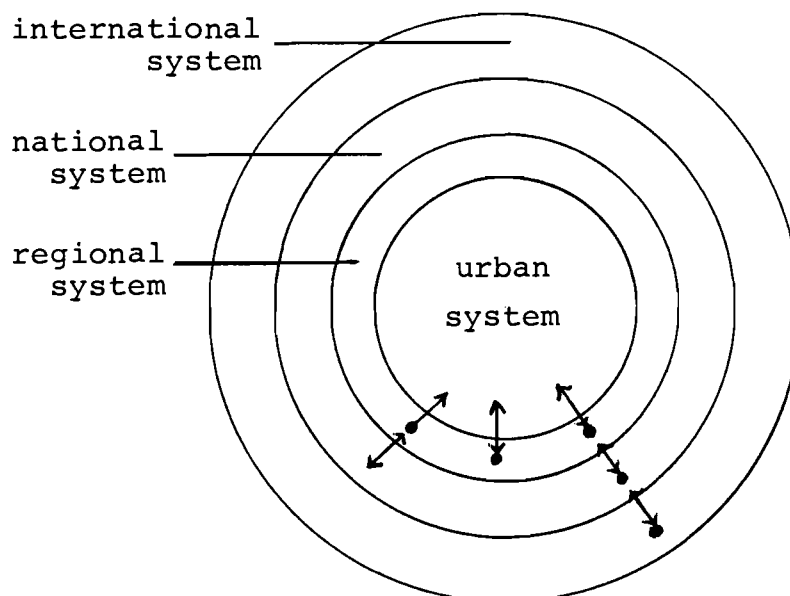

Figure 10. An illustrative representation of various planning levels.

A well-known problem inherent in any kind of regional information system is the spatial demarcation of the system concerned (in terms of cities, regions, etc.). From an analytical point of view, the spatial demarcation might be based on functional linkages between the spatial entities of the system at hand, although data availability very often hampers the application of this standpoint. From a planning point of view, the spatial demarcations might be based on the existing administrative framework, although here also data problems may emerge (see Hermansen 1969). This problem deserves closer attention in a further analysis of a MIS.

Frequently, information systems for regional planning have been developed in close connection with multiregional models. Multiregional models--as an extension of traditional econometric modeling--aim at providing consistent and coherent information on a complex spatial world, so as to identify the main driving forces and the mechanism of a complicated multiregional

system (see also Issaev et al. 1982). The aim of coherence and consistency will, in general, lead to a rejection of economic models that do not take into account the openness of a region. Thus, without a consideration of interregional and national-regional links, there is no consistency guarantee for the spatial system as a whole. Usually, there are various kinds of direct and indirect cross-regional linkages caused by spatio-temporal feedback and contiguity effects, so that regional developments may have a nation-wide effect. National or even international developments may also exert significant impacts on a spatial system; this is especially important because such developments may affect the competitive power of regions in a spatial system. For instance, a general national innovation policy may favor especially areas with large agglomerations. The diversity in an open spatial economic system requires coordination of planning activities on the national and regional level, leading to the necessity of using multiregional economic models in attempts to include regional profiles in national-regional development planning. This problem is also worth further investigation.

Let us now take a multiregional planning model focusing on one specific problem area (i.e. one specific profile) or on an integrated regional development pattern (including multiple profiles). Then we may assume the following general framework for a multi-level information system (see Figure 11).

The right-hand side of Figure 11 reflects the expected results in terms of values of objectives, goal variables, and other relevant endogenous variables. In fact, two main questions may be studied by means of Figure 11:

- what is the optimum use of a given data input?
- what is the optimum data input of the information system for a given set of uses?

It is clear that the second question is the dual to the first (primal) question. It should also be noted that the versatility for local data is much higher than for regional or national data, since they can be used to build 3 types of systems models and to assess 3 different types of profiles.

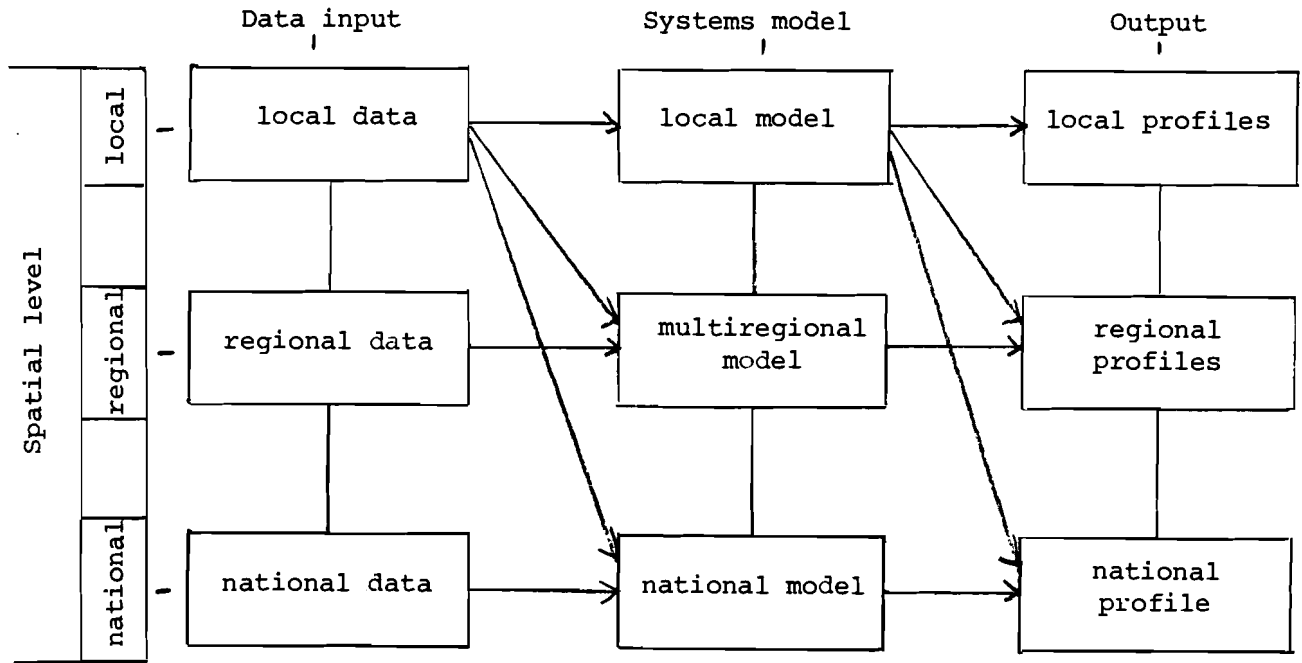

Figure 11. Structure of a multi-urban multi-region information system.

Furthermore, the output of this information system also displays some interesting features. Local profiles can only be obtained by means of local data and a local model, whereas a national profile can be assessed in many ways, according to the graphs represented in Figure 11; for instance, from local data via a multiregional model to a national profile. All such combinations of ways of composing the relevant profiles are certainly worth an in-depth analysis of specific real-world problem areas.

This problem is also closely related to the information loss by aggregating a system from a micro level to a meso or macro level, as this information loss may occur in each of the three abovementioned stages: data input, models, and final profiles. Similar problems may emerge in attempts to disaggregate existing data into data of a lower spatial level. These questions should also be addressed in further research.

Finally, also the related problem of bottom-up versus top-down approaches may be addressed in information systems, not

only from an institutional point of view but also from an analytical point of view (see also Nijkamp and Rietveld 1982b).

Apart from the abovementioned analytical questions, also various specific questions have to be addressed in order to build up an efficient information system for regional planning:

- what are the relevant variables for the profiles?
- what is the best model specification for the purpose at hand?
- which data are needed to estimate the model?
- which kind of impact analysis and evaluation analysis is the most appropriate for the purposes at hand?
- what is the best way of storing and up-dating this information in order to fulfill the criteria for information systems mentioned in Section 6?

All these questions imply certain tradeoffs, for instance, between the expected benefits of an information system and the costs of data collection and storage, or between the expected benefits of an information system and the costs of building a model. This is illustrated in a hypothetical way in Figure 12.

As mentioned before, the key question of building up an information system is the search for a compromise between these conflicting criteria. At present, the existing systems of information (statistics and specialized operative systems) are incomplete, inconsistent, and insufficiently oriented to the needs of the analysis of geographical aspects of socio-economic development planning. This situation leads to a lack of data for models, gaps in adequate use of information for the decision-making process, difficulties faced by users in making consistent decisions and in implementing models. Hence, the problem arises: how can the needs of information for planning integrated regional-national developments be fulfilled? The development of computerized information systems supporting regional and national planning and management has in recent years been marked by much progress and has led to a variety of meaningful experiences, the accumulation of which could greatly contribute to the solution of the above problem. Therefore, a rigorous endeavour

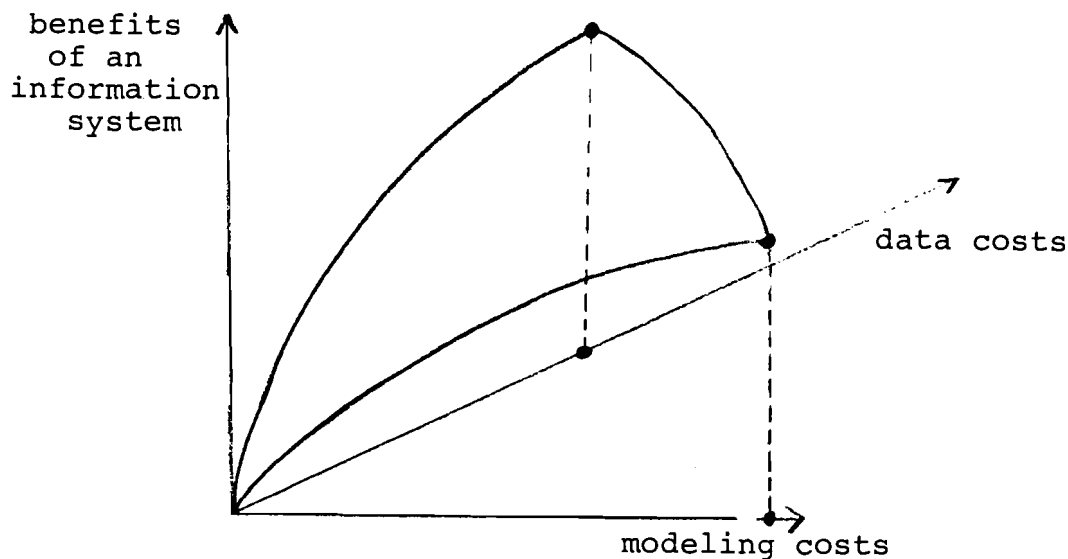

Figure 12. Trade-off curves between benefits and costs.

should be made to develop a systematic framework for a MIS in a specific geographical, socio-economic and institutional setting. The aims of such a research project should be:

- to generalize and evaluate international experience from the point of view of how an existing MIS corresponds to actual goals and problems of integrated regional development planning and management; special attention should be given to bottlenecks and lacking elements in information provision;
- to reveal the most progressive trends and elements in developing a MIS from the point of view of a systems analytic approach to regional development planning;
- to estimate perspectives and formulate recommendations relating to different aspects of regional information problems.

It is clear that the abovementioned project will be too broad to be carried out effectively in a limited time period. Therefore, it is necessary to provide a more distinct focus by addressing only a couple of important problem areas in the field of regional development planning, such as regional labor markets and regional energy planning. A cross-national inventory and comparison of a MIS for these problem areas is no doubt an extremely important endeavour for both model builders and planning agencies.

REFERENCES

- Baranov, E.F. and I.S. Matlin. 1982. System of models coordinating decisions for sectoral and regional development. In: Multiregional Economic Modeling: Practice and Prospect, edited by B. Issaev, et al. Amsterdam: North Holland. forthcoming.
- Benjamin, B. 1976. Statistics and Research in Urban Administration and Development. The Hague: International Association for Regional and Urban Statistics.
- Blitzer, C.R., P.B. Clark, and L. Taylor, eds. 1975. Economy-Wide Models and Development Planning. New York: Oxford University Press.
- Bowman, C.T. and R.E. Kutscher. 1980. The labor market data base for multiregional models. In: Modeling the Multiregional Economic System, edited by F.G. Adams and N.J. Glickman. Lexington, Massachusetts: D.C. Heath, pp. 57-64.
- Braybrooke, D. and C.E. Lindblom. 1979. A Strategy of Decision. New York: Free Press.
- Brouwer, F. and P. Nijkamp. 1981. Categorical spatial data analysis. Research memorandum 1981-22. Amsterdam: Free University, Department of Economics.
- Burch, J.G., F.R. Strater, and G. Grudnitski. 1979. Information Systems: Theory and Practice. New York: John Wiley.
- Casley, D.J. and D.A. Lury. 1981. Data Collection in Developing Countries. Oxford: Clarendon Press.
- Chadwick, G. 1971. A Systems View of Planning. Oxford: Pergamon Press.
- Elfick, M., ed. 1979. URPIS Seven. Melbourne: The Australian Urban and Regional Information Systems Association.
- Friedrich, P. and H.G. Wonnemann. 1981. Manual for Identifying the effects of the settlement of a public office. In: Locational Developments and Urban Planning, edited by W.F.J. van Lierop and P. Nijkamp. Alphen ad Rijn, The Netherlands: Sijthoff and Noordhoff, pp. 389-406.
- Garnick, D.H. 1980. The regional statistics system. In: Modeling the Multiregional Economic System, edited by F.G. Adams and N.J. Glickman. Lexington, Massachusetts: D.C. Heath, pp. 25-48.
- Glickman, N.J. 1980. Impact analysis with regional econometric models. In: Economic Impact Analysis, edited by S. Pleeter. Boston: Martinus Nyhoff.

- Gokhale, D.V. and S. Kullback. 1978. The Information in Contingency Tables. New York: Dekker.
- Guesnier, B. 1978. Le système d'information régional. University of Poitiers: Institute of Regional Economics (mimeographed).
- Hägerstrand, T. and A.R. Kuklinski, eds. 1971. Information Systems for Regional Development. Lund, Sweden: University of Lund, pp. 1-37.
- Harvey, D. 1969. Explanation in Geography. London: Arnold.
- Hermansen, T. 1969. Requirements and provision of information for regional development planning in Sweden. Geneva: UNRISD (mimeographed).
- Hermansen, T. 1971. Information systems for regional development planning. In: Information Systems for Regional Development, edited by T. Hägerstrand and A.R. Kuklinski. Lund, Sweden: University of Lund, pp. 1-37.
- Hordijk, L., H.M.A. Jansen, A.A. Olsthoorn, and J.B. Vos. 1980. Rekenen Informatiesysteem Milieuhygiene. Amsterdam: Free University, Institute for Environmental Studies.
- Issaev, B. 1982. Multiregional economic models in different planning and management systems. In: Practice and Prospect of Multiregional Economic Modeling, edited by B. Issaev, et al. Amsterdam: North-Holland. Forthcoming.
- Issaev, B., P. Nijkamp, P. Rietveld, and F. Snickars. 1982. Multiregional Economic Modeling: Practice and Prospect. Amsterdam: North-Holland. Forthcoming.
- Kuklinski, A.R., ed. 1974. Regional Information and Regional Planning. The Hague: Mouton.
- Langefors, B. 1966. Theoretical Analysis of Information Systems. Lund Sweden: University of Lund.
- Lichfield, N., P. Kettle, and M. Whitbread. 1975. Evaluation in the Planning Process. Oxford: Pergamon Press.
- Nesher, A. and A.P. Schinnar. 1981. Neighborhood and program multipliers of public-funded community development activities. In: Locational Developments and Urban Planning, edited by W.F.J. van Lierop and P. Nijkamp. Alphen ad Rijn, The Netherlands: Sijthoff and Noordhoff, pp. 389-406.
- Nijkamp, P. 1979. Multidimensional Spatial Data and Decision Analysis. Chichester/New York: John Wiley.
- Nijkamp, P. 1980. Environmental Policy Analysis. Chichester/New York: John Wiley.
- Nijkamp, P. 1982. Regional planning and urban impact analysis. In: Essays in Honor of Martin J. Beckmann, edited by

- R. Funck. Karlsruhe: Series Karlsruhe Studies in Regional Science. Forthcoming.
- Nijkamp, P. and P. Rietveld. 1982a. Soft econometrics as a tool in regional discrepancy analysis. In: Papers of the Regional Science Association 48. Forthcoming.
- Nijkamp, P. and P. Rietveld. 1982b. Structure analysis of spatial problems. In: Multiregional Economic Modeling: Practice and Prospect, edited by B. Issaev, et al. Amsterdam: North-Holland. Forthcoming.
- Park, S.-H., M. Mohtadi, and A. Kubursi. 1981. Errors in regional nonsurvey input-output models. In: Journal of Regional Science 21 (3): 321-229.
- Perrin, J.C. 1975. Le Développement Régional. Paris: Presses Universitaires de France.
- Pleeter, S. 1980. Economic Impact Analysis. Boston, Massachusetts: Martinus Nyhoff.
- Rees, P. and F. Willekens. 1981. Data Bases and Accounting Framework for IIASA's Comparative Migration and Settlement Study. CP-81-39. Laxenburg, Austria: International Institute for Applied Systems Analysis.
- Rietveld, P. 1980. Multiple Objective Decision Methods and Regional Planning. Amsterdam: North-Holland.
- Sowell, T. 1980. Knowledge and Decision. New York: Basic Books.
- Snickars, F. 1982. A Model System for Policy Impact Analysis in the Tuscany Region: A Progress Report. Laxenburg, Austria: International Institute for Applied Systems Analysis. Forthcoming.
- Torene, R. and D. Goettee. 1980. Towards a general purpose economic data base. In: Modeling the Multiregional Economic System, edited by F.G. Adams and N.J. Glickman. Lexington, Massachusetts: D.C. Heath, pp. 65-72.
- Voogd, J.H. 1982. Multiple Criteria Analysis in Public Planning. Ph.D. dissertation, Technical University, Eindhoven, The Netherlands.
- Wrigley, N. 1980. Categorical data, repeated measurement research designs and industrial surveys. In: Regional Studies 14: 455-471.