

# Working Paper

CONTINUOUS EXTRACTION UNDER RISK

*Peter Lohmander*

March 1986  
WP-86-16

**International Institute for Applied Systems Analysis  
A-2361 Laxenburg, Austria**

NOT FOR QUOTATION  
WITHOUT THE PERMISSION  
OF THE AUTHOR

## CONTINUOUS EXTRACTION UNDER RISK

*Peter Lohmander*

March 1986  
WP-86-16

*Working Papers* are interim reports on work of the International Institute for Applied Systems Analysis and have received only limited review. Views or opinions expressed herein do not necessarily represent those of the Institute or of its National Member Organizations.

INTERNATIONAL INSTITUTE FOR APPLIED SYSTEMS ANALYSIS  
2361 Laxenburg, Austria

### **The Author**

Master of Forestry, Peter Lohmander comes from the Swedish University of Agricultural Sciences, Department of Forest Economics in Umea, Sweden. The present paper was finished during his 12 week stay with the System and Decision Sciences YSSP Program, in 1985.

## **Foreword**

The solved problem stems from the requirement to find an optimal extraction strategy in resource economics, namely, in forest harvesting. The author aims to take into account both the stochastic and dynamic features of the problem, and discusses its economic background as well. Through its actual motivation and interdisciplinary features, the resulting paper is an example that some of IIASA's objectives can be met within the framework of the Young Scientists' Summer Program with SDS.

Alexander B. Kurzhanski  
Chairman  
System and Decision Sciences Program

## Abstract

The problem of optimal intertemporal extraction (harvest) of a resource is investigated. The resource stock and the price (exogenous) are Markov processes. The expected present value of all future profits is maximized. The effects of increasing risk in the process increments in the future on the present optimal control (the present extraction level) are investigated.

It is proved that increasing risk in the increments of the stochastic price – and growth – processes may imply higher or lower optimal present extraction.

The results are dependent on;

- a Autocorrelation and stationarity in the price process
- b The first three derivatives of the extraction cost function
- c The first three derivatives of the deterministic part of the growth process

The effect of increasing risk in the process increments on the sign of the optimal change in the present extraction level can be unambiguously determined in several cases.

## **Acknowledgments**

The author is grateful to the Swedish Council for Planning and Coordination of Research, Forskarutbildningsnämnden at the Swedish University of Agricultural Sciences and Fonden för Skogsvetenskaplig Forskning. The main part of the analysis was made at IIASA, Department of System and Decision Sciences, thanks to their founding. Academician A. Kurzanski created an atmosphere of inspiration in the department.

## Contents

	page
<u>1. Introduction</u>	1
1.1. The problem	1
1.2. Earlier work in the field	1
<u>2. Analysis</u>	3
2.1. Variables and parameters	3
2.2. The problem	4
2.3. Optimal policy at time $t$	5
2.4. The expected marginal present value of the resource stock saved for the future under increasing risk in the process increments	11
2.5. Implications of increasing risk in the process increments in the future for the optimal present extraction level	22
2.6. Can the signs of $\phi_{hh}$ and $\phi_{yy}$ be unambiguously determined ?	24
2.7. An example	29
<u>3. Discussion</u>	39

## 1 Introduction

### 1.1 The problem

The question under investigation is whether or not the present extraction level should increase or decrease under the influence of increasing risk in the stochastic price process and/or the stochastic growth process.

The question will be analyzed under the assumption of risk neutrality and it is hence assumed that the firm maximizes the expected present value of future extraction over a T period horizon.

The result should be of interest to firms in most resource industries. Typical applications can be found in the oil, coal and mineral sectors.

However, since both prices and growth are treated as stochastic processes, other applications are optimal harvesting in agriculture and fishing.

The general assumptions are the following;

- The aim is to maximize the expected present value of all future profits from extraction
- Price is a Markov process, exogenous to the enterprise
- The size of the natural resource stock is a controlled diffusion process, where the control variable is the extraction level.

### 1.2 Earlier work in the field

The method of dynamic programming was originally presented by Bellman (1). An early discussion about diffusion processes is given by Ito and McKean (6). Fleming and Rishel (4) give a detailed presentation of deterministic and stochastic optimal control. A well written introduction to the theory of optimal control of stochastic differential equation systems is given by Chow (2).

In this paper we deal with a diffusion process where the living stock grows according to a stochastic process. The problem of the resource manager is to choose the optimal harvest level in every moment.



Earlier investigations of similar problems have given unambiguous results because of very restrictive assumptions about the functional form of the pay off function and the growth function.

Gleit (5) investigates a problem similar to the one of this paper. However, he makes very restrictive assumptions concerning the growth function and the utility function of the resource owner. According to Gleit, the utility function is of the form (1.2.1) and the growth function of the form (1.2.2). The profit function is defined in (1.2.3).

$$U(\pi) = \frac{\pi}{T} \quad (1.2.1)$$

( $\pi$  = profit,  $0 < T < 1$ )

$$dx_t = [k(t)x_t - h(x_t, t)]dt + x_t \sigma(t) dW_t \quad (1.2.2)$$

$$x_0 = c > 0$$

$x_t$  = size of living stock at time  $t$

$k(t)$  = possibly time dependent constant

$h$  = harvest level

$W_t$  = Wiener process

$\sigma^2(t)$  = variance of the growth rate

$$\pi = A(t)h(x, t) - B(t)x \quad (1.2.3)$$

$A(t), B(t)$  = time dependent constants

The result derived by Gleit is that the optimal present harvest level is an increasing function of the variance of the growth rate.

In the present analysis it will be demonstrated that;

- The result derived by Gleit crucially depends on the restrictive choice of growth function, the choice of profit function and the assumption that the uncertainty concerns the growth rate and not for instance the growth.

Furthermore, Gleit assumes price to be deterministic. In the analysis of this paper, the stochastic properties of the price process are also given attention. In fact, the relative variations in prices may be much larger than the relative fluctuations in the resource stock in many cases. This has often been the case in for instance the mineral sector and the forest sector. (There may be no growth at all in the minerals and the size of the forest resource generally changes less than a few per cent over a year.)

May, Beddington, Harwood and Shepherd (7) investigate the dynamic aspects of fish and whale populations under density independent and density dependent random noise that affects the per capita vital rates. They conclude that, "the choice of an optimal management strategy clearly involves a decision about the relative emphasis placed on the magnitude of the yield compared with its stability". "The search for such robust strategies is central to the management of fisheries in an uncertain world."

Clearly, there are many factors that affect the optimal extraction level under risk. Let us now turn to the formal analysis of the question of this paper.

## 2 Analysis

### 2.1 Variables and parameters

$W_t(P_{t-1}, \psi_{t-1})$  Expected present value of all profits from extraction in the periods  $[t, \dots, T]$  at time  $(t-1)$  as a function of the price and the saved resource stock at time  $t-1$  when all future harvest levels  $[t, \dots, T]$  are optimally chosen. ( $P_t$  and  $Q_t$  have not yet been revealed.)

$h_t$  harvest level at time  $t$ .

$\psi_t$  size of resource stock saved at time  $t$  for future purposes.

$P_t$  price at time  $t$ .

$Q_t$	size of resource stock at time $t$ before harvest $h_t$ .
$F'(P_t   P_{t-1})$	probability density function of $P_t$ conditional on $P_{t-1}$ .
$G'(Q_t   \Psi_{t-1})$	probability density function of $Q_t$ conditional on the size of the saved stock last period.
$\varepsilon_t^P, \varepsilon_t^Q$	stochastic variables that are statistically independent over time. Furthermore, $\varepsilon_t^P$ and $\varepsilon_t^Q$ are independent of each other. $E(\varepsilon_t^P) = E(\varepsilon_t^Q) = 0$ .
$\phi_t(h_t, P_t, Q_t)$	expected present value of all profits from extraction in the periods $[t, \dots, T]$ at time $t$ when $P_t$ and $Q_t$ have been revealed and optimal harvesting is assumed in period $[t+1, \dots, T]$ ,
$r$	rate of interest in the capital market.
$V_t(h_t, P_t)$	profit generated at time $t$ ( $= P_t h_t - C_t(h_t)$ ).
$C_t(h_t)$	cost function at time $t$ .
$\lambda_t(\cdot)$	expected marginal present value of the resource stock at time $t$ when $P_t$ and $Q_t$ have been revealed.

## 2.2 The problem

The problem is to maximize the expected present value of all future profits in every time period.

$$W_t(P_{t-1}, \Psi_{t-1}) = \iint \max_{h_t} \phi_t(h_t, P_t, Q_t) F'(P_t | P_{t-1}) dp_t G'(Q_t | [Q_{t-1} - h_{t-1}]) dQ_t \quad (2.2.1)$$

$$P_{t+1} = P_{t+1}(P_t, t) + \varepsilon_t^P \quad (2.2.2)$$

$$Q_{t+1} = Q_{t+1}([Q_t - h_t], t) + \varepsilon_t^Q \quad (2.2.3)$$

In the main part of the analysis, the following specifications are used;

$$\phi_t(h_t, P_t, Q_t) = e^{-rt} V_t(h_t, P_t) + W_{t+1}(\Psi_t, P_t) \quad (2.2.4)$$

where  $V_t(\cdot)$  is defined as

$$V_t(h_t, P_t) = P_t h_t - C_t(h_t) \quad (2.2.5)$$

and

$$\Psi_t = Q_t - h_t \quad (2.2.6)$$

### 2.3 Optimal policy at time t

Just before  $P_t$  and  $Q_t$  have been observed, the expected present value of the profits in the periods  $[t, t+1, \dots, T-1, T]$  is  $W_t(P_{t-1}, \Psi_{t-1})$ , which is defined in (2.2.1). When  $P_t$  and  $Q_t$  have been observed, the problem is to maximize  $\phi_t(\cdot)$  with respect to the policy variable  $h_t$ . However, since  $W_{t+1}$  is a function of  $\Psi_t (= Q_t - h_t)$ , it is most convenient to maximize  $\phi_t(\cdot)$  with respect to  $h_t$  and  $\Psi_t$ . This way many useful results are given explicitly. Hence, the problem in period  $t$ , when  $P_t$  and  $Q_t$  are revealed, is given in (2.3.1). An interior solution is assumed optimal

$$\begin{aligned} \max_{h_t, \Psi_t} \quad & \phi_t(h_t, \Psi_t; P_t, Q_t) & (2.3.1) \\ \text{s.t.} \quad & h_t + \Psi_t = Q_t \end{aligned}$$

In the following analysis, the notation will be as simplified as possible.

The Lagrange function corresponding to (2.3.1) is (2.3.2)

$$L = \phi(h, \Psi) + \lambda_t(Q - h - \Psi) \quad (2.3.2)$$

The first order optimum conditions are (an interior solution is assumed optimal)

$$\begin{aligned} L_{\lambda} &= Q - h - \Psi = 0 \\ L_h &= \phi_h - \lambda = 0 \\ L_{\Psi} &= \phi_{\Psi} - \lambda = 0 \end{aligned} \quad (2.3.3)$$

From (2.3.3) we extract (2.3.4) which implies that the marginal value of present extraction should be equal to the expected marginal value of the resource if it is saved for future purposes.

$$\phi_h = \lambda = \phi_\Psi \quad (2.3.4)$$

A more explicit form of (2.3.4) is (2.3.5). This equation is obtained through the use of (2.2.4), (2.2.5) and (2.2.6).

$$e^{-rt} [p_t - C'_t] = \lambda_t = \frac{\partial W_{t+1}(\cdot)}{\partial \Psi_t} \quad (2.3.5)$$

Define [ D ] as the matrix of second order derivatives.

$$[ D ] = \begin{bmatrix} 0 & -1 & -1 \\ -1 & \phi_{hh} & 0 \\ -1 & 0 & \phi_{\Psi\Psi} \end{bmatrix} \quad (2.3.6)$$

The second order maximum condition is (2.3.7)

$$| D | = - \phi_{\Psi\Psi} - \phi_{hh} > 0 \quad (2.3.7)$$

### Assumption 1

$$\phi_{\Psi\Psi} < 0, \phi_{hh} < 0$$

### Remark 1

From assumption 1 follows that the second order maximum condition is fulfilled.

Let us investigate how the optimal choice variables  $h_t^*$ ,  $\Psi_t^*$  and the expected marginal present value of the resource  $\lambda_t^*$  are affected by changes in the parameters at time t!

Total differentiation of (2.3.3) gives (2.3.8)

$$[D] \begin{bmatrix} d\lambda_t^* \\ dh_t^* \\ d\psi_t^* \end{bmatrix} = \begin{bmatrix} -dQ_t \\ -\phi_{hP} dP_t \\ -\phi_{\psi P} dP_t \end{bmatrix} \quad (2.3.8)$$

The derivative of the expected marginal present value of the resource at time  $t$  with respect to the price at time  $t$  is obtained through Cramer's rule,

$$\frac{\partial \lambda_t^*}{\partial P_t} = \frac{\begin{vmatrix} 0 & -1 & -1 \\ -\phi_{hP} & \phi_{hh} & 0 \\ -\phi_{\psi P} & 0 & \phi_{\psi\psi} \end{vmatrix}}{|D|} \quad (2.3.9)$$

$$\frac{\partial \lambda_t^*}{\partial P_t} = \frac{-\phi_{hP}\phi_{\psi\psi} - \phi_{hh}\phi_{\psi P}}{|D|} \quad (2.3.10)$$

From Assumption 1 we know that  $\phi_{\psi\psi} < 0$ ,  $\phi_{hh} < 0$  and  $|D| > 0$ . From (2.2.4) and (2.2.5) it is clear that  $\phi_{hP} > 0$ .  $\phi_{\psi P}$  is the derivative of the expected marginal value of the resource saved for future extraction with respect to the present price.

### Assumption 2

The autocorrelation in the price process is nonnegative.

### Remark 2

From Assumption 2 it follows that  $\phi_{\psi P} > 0$ . Hence,  $\frac{\partial \lambda_t^*}{\partial P_t} > 0$ .

The implication of Remark 2 is that the expected marginal present value of the resource is strictly increasing in the present price. The result is, however, dependent on the stochastic properties of the price process.

Should the present harvest level increase when the present price increases?

$$\frac{\partial h_t^*}{\partial P_t} = \frac{\begin{vmatrix} 0 & 0 & -1 \\ -1 & -\phi_{hP} & 0 \\ -1 & -\phi_{\psi P} & \phi_{\psi\psi} \end{vmatrix}}{|D|} \quad (2.3.11)$$

$$\frac{\partial h_t^*}{\partial P_t} = \frac{-\phi_{\psi P} + \phi_{hP}}{|D|} \quad (2.3.12)$$

### Assumption 3

$$\phi_{hP} > \phi_{\psi P}$$

### Remark 3

Assumption 3 is a rather strong assumption, ( $\phi_{hP} > \phi_{\psi P}$ ). Consider the two period extraction problem

$$\begin{aligned} \max_{h_{T-1}} E_{T-1}(\pi) &= e^{-r(T-1)} [P_{T-1} h_{T-1} - C_{T-1}(h_{T-1})] + \\ &e^{-rT} [E_{T-1}(P_T | P_{T-1}) Q_T(\cdot) - C_T(Q_T(\cdot))] \\ \text{s.t. } Q_T &= Q_T(Q_{T-1} - h_{T-1}) \end{aligned}$$

where  $\pi$  denotes the total present value of profits from extraction.

The first order optimum condition is;

$$e^{-r(T-1)} \left\{ [P_{T-1} - C'_{T-1}] + e^{-r} [E_{T-1}(P_T | P_{T-1}) - C'_T] \frac{\partial Q_T}{\partial h_{T-1}} \right\} = 0$$

Hence, the following equation should hold;

$$[P_{T-1} - C'_{T-1}] = [E_{T-1}(P_T | P_{T-1}) - C'_T] e^{-r} Q'_T$$

Assume that  $C_t(\cdot)$  is identical in both periods, that  $h_{T-1}^* = Q_T$  and that  $E_{T-1}(P_T) = a + bP_{T-1}$ . Then it follows that;

$$P_{T-1} - C' = (a + bP_{T-1} - C') e^{-r} Q_T'$$

Assume further that  $P_{T-1} = E(P_T | P_{T-1})$  for  $P_{T-1} = P_0$

Then we get the equality;

$$P_0 - C' = (P_0 - C') e^{-r} Q_T'$$

Obviously,

$$Q_T' = e^r$$

at this point. (The marginal relative growth is equal to the rate of interest in the capital market.)

Let us determine  $\phi_{hP}$  and  $\phi_{\Psi P}$  at time (T-1)!

$$\phi_{hP} = e^{-r(T-1)}$$

$$\phi_{\Psi P} = be^{-r(T-1)}$$

Assumption 3 hence implies that  $b < 1$ .

Observation; In some cases Assumption 3 implies that the price process is not a martingale or a submartingale but perhaps a stationary first order autoregressive process.

From Assumption 3 it follows that the present optimal extraction level is a strictly increasing function of the present price. Note that, at least

in the 2 period case,  $\frac{\partial h_t^*}{\partial P_t} = 0$  under the assumption of martingale prices!

$$\frac{\partial \Psi_t^*}{\partial P_t} = \frac{\begin{vmatrix} 0 & -1 & 0 \\ -1 & \phi_{hh} & -\phi_{hP} \\ -1 & 0 & -\phi_{\Psi P} \end{vmatrix}}{|D|}$$

(2.3.13)



$$\frac{\partial \Psi_t^*}{\partial P_t} = \frac{-\phi_{hP} + \phi_{\Psi P}}{|D|} \tag{2.3.14}$$

Once more, we make use of Assumption 3. We conclude that the optimal amount of the resource that should be saved for future purposes is a decreasing function of the present price. The price process assumptions are however critical to the results.

	$\frac{\partial \lambda_t^*}{\partial P_t}$	$\frac{\partial h_t^*}{\partial P_t}$	$\frac{\partial \Psi_t^*}{\partial P_t}$
Value	> 0	> 0	< 0
Critical assumptions	1,2	1,3	1,3

Table 1 Derivatives with respect to  $P_t$

Let us investigate how changes in  $Q_t$  affect  $h_t^*$ ,  $\Psi_t^*$  and  $\lambda_t^*$ . From (2.3.8) we get (2.3.15).

$$\frac{\partial \lambda_t^*}{\partial Q_t} = \frac{\begin{vmatrix} -1 & -1 & -1 \\ 0 & \phi_{hh} & 0 \\ 0 & 0 & \phi_{\Psi\Psi} \end{vmatrix}}{|D|} \tag{2.3.15}$$

$$\frac{\partial \lambda_t^*}{\partial Q_t} = \frac{-\phi_{hh}\phi_{\Psi\Psi}}{|D|} \tag{2.3.16}$$

From Assumption 1 it is clear that  $\lambda_t^*$  is a strictly decreasing function of the resource quantity  $Q_t$ .

$$\frac{\partial h_t^*}{\partial Q_t} = \frac{\begin{vmatrix} 0 & -1 & -1 \\ -1 & 0 & 0 \\ -1 & 0 & \phi_{\Psi\Psi} \end{vmatrix}}{|D|} \tag{2.3.17}$$

$$\frac{\partial h_t^*}{\partial Q_t} = \frac{-\phi_{\Psi\Psi}}{|D|} \tag{2.3.18}$$

$$\frac{\partial \Psi_t^*}{\partial Q_t} = \frac{\begin{vmatrix} 0 & -1 & -1 \\ -1 & \phi_{hh} & 0 \\ -1 & 0 & 0 \end{vmatrix}}{|D|} \tag{2.3.19}$$

$$\frac{\partial \Psi_t^*}{\partial Q_t} = \frac{-\phi_{hh}}{|D|} \tag{2.3.20}$$

Obviously, both  $h_t^*$  and  $\Psi_t^*$  are strictly increasing functions of the available resource stock. The results are summarized in table 2.

Table 2 Derivatives with respect to  $Q_t$

	$\frac{\partial \lambda_t^*}{\partial Q_t}$	$\frac{\partial h_t^*}{\partial Q_t}$	$\frac{\partial \Psi_t^*}{\partial Q_t}$
Value	< 0	> 0	> 0
Critical assumptions	1	1	1

2.4 The expected marginal present value of the resource stock saved for the future under increasing risk in the process increments

In this section, the aim is to investigate how  $\frac{\partial W_t(P_{t-1}, \Psi_{t-1})}{\partial \Psi_{t-1}}$  is affected by increasing risk in the price and growth processes between period  $t-1$  and  $t$ . Increasing risk thus occurs in  $\epsilon_{t-1}^P$  and  $\epsilon_{t-1}^Q$ .

$$W_t(P_{t-1}, \Psi_{t-1}) = \iint \max_{h_t, \Psi_t} \phi(h_t, \Psi_t; P_t, Q_t) F'(P_t | P_{t-1}) dp_t G'(Q_t | \Psi_{t-1}) dQ_t \quad (2.4.1)$$

If it can be shown that the expected marginal present value of the resource saved for future purposes increases (is unchanged) (decreases) as the risk in  $\epsilon_{t-1}^P$  and/or  $\epsilon_{t-1}^Q$  increases, then it can be proved that the optimal extraction level in period t-1 decreases (is unchanged) (increases).

In some cases, the risk effect on the expected marginal value of the "saved" resource affects earlier time periods. This problem will be discussed in some detail in the following sections.

Equation (2.4.1) is identical to (2.4.2) when  $G'(\cdot)$  denotes the probability density function of  $\epsilon_{T-1}^Q$ .

$$W_t(P_{t-1}, \Psi_{t-1}) = \iint \max_{h_t, \Psi_t} \phi(h_t, \Psi_t; P_t, [E_{t-1}(Q_t(\Psi_{t-1})) + \epsilon_{t-1}^Q]) \quad (2.4.2)$$

$$F'(P_t | P_{t-1}) dp_t G'(\epsilon_{t-1}^Q) d\epsilon_{t-1}^Q$$

The expected marginal present value of the saved resource at time t-1 is given in (2.4.3).

$$\frac{\partial W_t(P_{t-1}, \Psi_{t-1})}{\partial \Psi_{t-1}} = \{ \iint \min_{h_t, \Psi_t} \lambda_t(h_t, \Psi_t; P_t, [E_{t-1}(Q_t(\Psi_{t-1})) + \epsilon_{t-1}^Q]) \quad (2.4.3)$$

$$F'(P_t | P_{t-1}) dp_t G'(\epsilon_{t-1}^Q) d\epsilon_{t-1}^Q \} \frac{\partial E_{t-1}(Q_t)}{\partial \Psi_{t-1}}$$

#### Remark 4

If we assume that  $\frac{\partial E_{t-1}(Q_t)}{\partial \Psi_{t-1}} > 0$ , which is a very weak growth condition, it is clear from (2.4.3) that  $\frac{\partial W_t(P_{t-1}, \Psi_{t-1})}{\partial \Psi_{t-1}}$  is an increasing function of  $E_{t-1}(\lambda_t^*)$ .

From Remark 4 we notice that the change in  $\frac{\partial W_t(\cdot)}{\partial \Psi_{t-1}}$  from increasing risk in  $\varepsilon_{t-1}^P$  and  $\varepsilon_{t-1}^Q$  can be extracted from the changes in  $E_{t-1}(\lambda_t^*)$ . In order to determine if  $E_{t-1}(\lambda_t^*)$  increases or decreases from risk increases in the parameters, we must investigate if  $\lambda_t^*$  is strictly convex, linear or strictly concave in the parameters!

First, we investigate the second order derivative of  $\lambda_t^*$  with respect to  $P_t$ . From (2.3.10) we get (2.4.4).

$$\frac{\partial \lambda_t^*}{\partial P_t} = \frac{\phi_{hP} \phi_{\Psi\Psi} + \phi_{hh} \phi_{\Psi P}}{\phi_{\Psi\Psi} + \phi_{hh}} \quad (2.4.4)$$

Denote the total derivative of (2.4.4) with respect to  $P_t$  as in (2.4.5);

$$\frac{\partial}{\partial P_t} \left( \frac{\partial \lambda_t^*}{\partial P_t} \right) = \frac{\partial^2 \lambda_t^*}{\partial P_t^2} + \frac{\partial^2 \lambda_t^*}{\partial P_t \partial h_t} \frac{\partial h_t^*}{\partial P_t} + \frac{\partial^2 \lambda_t^*}{\partial P_t \partial \Psi_t} \frac{\partial \Psi_t^*}{\partial P_t} \quad (2.4.5)$$

$$\frac{\partial^2 \lambda_t^*}{\partial P_t^2} = \left\{ \frac{1}{(\phi_{\Psi\Psi} + \phi_{hh})^2} \right\} \left\{ [\phi_{hPP} \phi_{\Psi\Psi} + \phi_{hP} \phi_{\Psi\Psi P} + \phi_{hhP} \phi_{\Psi P} + \phi_{hh} \phi_{\Psi PP}] \right. \\ \left. [\phi_{\Psi\Psi} + \phi_{hh}] - [\phi_{hP} \phi_{\Psi\Psi} + \phi_{hh} \phi_{\Psi P}] [\phi_{\Psi\Psi P} + \phi_{hhP}] \right\} \quad (2.4.6)$$

#### Assumption 4

$$[\phi_t(\cdot) = e^{-rt} [P_t h_t - C_t(h_t)] + W_t(P_t, \Psi_t)] \rightarrow \phi_{hPP} = 0, \phi_{hhP} = 0$$

#### Remark 5

From (2.4.6) and Assumption 4 we get;

$$\frac{\partial^2 \lambda_t^*}{\partial P_t^2} = \{x\} \phi_{hh} \{ \phi_{\Psi PP} [\phi_{\Psi\Psi} + \phi_{hh}] + \phi_{\Psi\Psi P} [\phi_{hP} - \phi_{\Psi P}] \}$$

$$\begin{array}{cccc} > 0 < 0 & & < 0 & & > 0 \end{array}$$

where  $\{x\} = \left\{ \frac{1}{(\phi_{\Psi\Psi} + \phi_{hh})^2} \right\} (> 0)$

Obviously, the sign of  $\frac{\partial^2 \lambda_t^*}{\partial P_t^2}$  depends on  $\phi_{\Psi\Psi}$  and  $\phi_{\Psi\Psi P}$ .

$$\frac{\partial^2 \lambda_t^*}{\partial P_t \partial h_t} = \left\{ \frac{1}{(\phi_{\Psi\Psi} + \phi_{hh})^2} \right\} \left\{ \begin{aligned} & [\phi_{hhP} \phi_{\Psi\Psi} + \phi_{hP} \phi_{\Psi\Psi h} + \phi_{hhh} \phi_{\Psi P} + \phi_{hh} \phi_{\Psi P h}] \\ & [\phi_{\Psi\Psi} + \phi_{hh}] - [\phi_{hP} \phi_{\Psi\Psi} + \phi_{hh} \phi_{\Psi P}] [\phi_{\Psi\Psi h} + \phi_{hhh}] \end{aligned} \right\} \quad (2.4.7)$$

Remark 6

(Assumption 4)  $\rightarrow$

$$\phi_{hhP} = 0, \phi_{\Psi\Psi h} = 0, \phi_{\Psi P h} = 0, \phi_{\Psi\Psi h} = 0$$

From Remark 6 it is clear that (2.4.7) reduces to (2.4.8).

$$\frac{\partial^2 \lambda_t^*}{\partial P_t \partial h_t} = \frac{\phi_{hhh} \phi_{\Psi\Psi} [\phi_{\Psi P} - \phi_{hP}]}{(\phi_{\Psi\Psi} + \phi_{hh})^2} \quad (2.4.8)$$

Remark 7

From (2.4.8) it is clear that  $\text{sgn} \left( \frac{\partial^2 \lambda_t^*}{\partial P_t \partial h_t} \right) = \text{sgn} (\phi_{hhh})$  since  $\phi_{\Psi\Psi} < 0$  (by Assumption 1) and  $[\phi_{\Psi P} - \phi_{hP}] < 0$  (by Assumption 3). See also Remark 3!

$$\frac{\partial^2 \lambda_t^*}{\partial P_t \partial \Psi_t} = \left\{ \frac{1}{(\phi_{\Psi\Psi} + \phi_{hh})^2} \right\} \left\{ \begin{aligned} & [\phi_{hP\Psi} \phi_{\Psi\Psi} + \phi_{hP} \phi_{\Psi\Psi\Psi} + \phi_{hh\Psi} \phi_{\Psi P} + \phi_{hh} \phi_{\Psi\Psi P}] \\ & [\phi_{\Psi\Psi} + \phi_{hh}] - [\phi_{hP} \phi_{\Psi\Psi} + \phi_{hh} \phi_{\Psi P}] [\phi_{\Psi\Psi\Psi} + \phi_{hh\Psi}] \end{aligned} \right\} \quad (2.4.9)$$

Remark 8

(Assumption 4)  $\rightarrow$

$$\phi_{hP\Psi} = 0, \phi_{hh\Psi} = 0$$

From Remark 8 it is clear that (2.4.9) reduces to (2.4.10)

$$\frac{\partial^2 \lambda_t^*}{\partial P_t \partial \Psi_t} = \left\{ \frac{\phi_{hh}}{(\phi_{\Psi\Psi} + \phi_{hh})^2} \right\} \left[ \underbrace{\phi_{\Psi\Psi\Psi}(\phi_{hP} - \phi_{\Psi P})}_{> 0} + \underbrace{\phi_{\Psi\Psi P}(\phi_{\Psi\Psi} + \phi_{hh})}_{< 0} \right] \quad (2.4.10)$$

Remark 9

From (2.4.10) it is clear that  $\text{sgn} \left( \frac{\partial^2 \lambda_t^*}{\partial P_t \partial \Psi_t} \right)$  depends on  $\phi_{\Psi\Psi\Psi}$  and  $\phi_{\Psi\Psi P}$  since  $\phi_{hh} < 0$ ,  $(\phi_{\Psi\Psi} + \phi_{hh}) < 0$  by Assumption 1 and  $(\phi_{hP} - \phi_{\Psi P}) > 0$  by Assumption 3. See also Remark 3!

Now the time has come to write  $\frac{\partial \lambda_t^*}{\partial P_t}$  explicitly! By using Remark 5, (2.4.8), (2.4.10), (2.3.12) and (2.3.14), we can express (2.4.5) as (2.4.11):

$$\frac{\partial \lambda_t^*}{\partial P_t} = \left[ \frac{\phi_{\Psi P P} \phi_{hh} [\phi_{\Psi\Psi} + \phi_{hh}] + \phi_{\Psi\Psi P} \phi_{hh} [\phi_{hP} - \phi_{\Psi P}]}{(\phi_{\Psi\Psi} + \phi_{hh})^2} \right] \left( \frac{\partial^2 \lambda_t^*}{\partial P_t^2} \right)$$

$$+ \left[ \frac{\phi_{hh} \phi_{\Psi\Psi} [\phi_{\Psi P} - \phi_{hP}]}{(\phi_{\Psi\Psi} + \phi_{hh})^2} \right] \left[ \frac{(\phi_{\Psi P} - \phi_{hP})}{(\phi_{\Psi\Psi} + \phi_{hh})} \right] \left( \frac{\partial^2 \lambda_t^*}{\partial P_t \partial h_t} \right) \left( \frac{\partial h_t^*}{\partial P_t} \right) \quad (2.4.11)$$

$$\begin{aligned}
& \left( \frac{\partial^2 \lambda_t^*}{\partial P_t \partial \Psi_t} \right) \quad \left( \frac{\partial \Psi_t^*}{\partial P_t} \right) \\
& + \left[ \frac{\phi_{\Psi\Psi\Psi} \phi_{hh} [\phi_{hP} - \phi_{\Psi P}] + \phi_{\Psi\Psi P} \phi_{hh} [\phi_{\Psi\Psi} - \phi_{hh}]}{(\phi_{\Psi\Psi} + \phi_{hh})^2} \right] \left[ \frac{(\phi_{hP} - \phi_{\Psi P})}{(\phi_{\Psi\Psi} + \phi_{hh})} \right]
\end{aligned}$$

(2.4.11) can be simplified to (2.4.12):

$$\begin{aligned}
\frac{\frac{\partial \lambda_t^*}{\partial P_t}}{\$ P_t} &= \mathcal{H}_1 [\phi_{hhh} \phi_{\Psi\Psi} + \phi_{\Psi\Psi\Psi} \phi_{hh}] \\
&< 0 \quad < 0 \quad < 0 \\
&+ \mathcal{H}_2 \left[ \phi_{\Psi P P} \underbrace{(\phi_{\Psi\Psi} + \phi_{hh})}_{< 0} + \phi_{\Psi\Psi P} \underbrace{(\phi_{hP} - \phi_{\Psi P})}_{> 0} \left( 1 + \frac{1}{\underbrace{(\phi_{\Psi\Psi} + \phi_{hh})}_{< 0}} \right) \right] \\
&< 0
\end{aligned} \tag{2.4.12}$$

where  $\mathcal{H}_1$  and  $\mathcal{H}_2$  are defined in (2.4.13).

$$\begin{aligned}
\mathcal{H}_1 &= \frac{(\phi_{\Psi P} - \phi_{hP})^2}{(\phi_{\Psi\Psi} + \phi_{hh})^3} < 0 \\
\mathcal{H}_2 &= \frac{\phi_{hh}}{(\phi_{\Psi\Psi} + \phi_{hh})^2} < 0
\end{aligned} \tag{2.4.13}$$

Remark 10

From (2.4.12) and (2.4.13) it is clear that  $\text{sgn} \left( \frac{\partial \lambda_t^*}{\partial P_t} \right)$  can be unambiguously determined in some cases and depends on  $\phi_{hhh}$ ,  $\phi_{\Psi\Psi\Psi}$ ,  $\phi_{\Psi P P}$ ,  $\phi_{\Psi\Psi P}$ .

Result 1

$\text{Sgn}(\beta_1)$  has been determined in the proceeding analysis.

$$\beta_1 = \left[ \begin{array}{c} \frac{\partial \lambda_t^*}{\partial p_t} \\ \frac{\partial \lambda_t^*}{\partial Q_t} \end{array} \right] \left\{ \begin{array}{l} > \\ = \\ < \end{array} \right\} 0 + \lambda_t^* \text{ is } \left\{ \begin{array}{l} \text{str. convex} \\ \text{linear} \\ \text{str. concave} \end{array} \right\} \text{ in } P_t.$$

Now the time has come to investigate the second order derivative of  $\lambda_t^*$  with respect to  $Q_t$ ! From (2.3.16) we get (2.4.14);

$$\frac{\partial \lambda_t^*}{\partial Q_t} = \frac{\phi_{hh} \phi_{\Psi\Psi}}{\phi_{\Psi\Psi} + \phi_{hh}} \quad (2.4.14)$$

Denote the total derivative of (2.4.14) with respect to  $Q_t$  as in (2.4.15);

$$\frac{\partial \left( \frac{\partial \lambda_t^*}{\partial Q_t} \right)}{\partial Q_t} = \frac{\partial^2 \lambda_t^*}{\partial Q_t^2} + \frac{\partial^2 \lambda_t^*}{\partial Q_t \partial h_t} \frac{\partial h_t^*}{\partial Q_t} + \frac{\partial^2 \lambda_t^*}{\partial Q_t \partial \Psi_t} \frac{\partial \Psi_t^*}{\partial Q_t} \quad (2.4.15)$$

$$\frac{\partial^2 \lambda_t^*}{\partial Q_t^2} = \left\{ \frac{1}{(\phi_{\Psi\Psi} + \phi_{hh})^2} \right\} \left\{ [\phi_{hhQ} \phi_{\Psi\Psi} + \phi_{hh} \phi_{\Psi\Psi Q}] \right. \\ \left. [\phi_{\Psi\Psi} + \phi_{hh}] - [\phi_{hh} \phi_{\Psi\Psi}] [\phi_{\Psi\Psi Q} + \phi_{hhQ}] \right\} \quad (2.4.16)$$

$$\frac{\partial^2 \lambda_t^*}{\partial Q_t^2} = \frac{(\phi_{hh})^2 \phi_{\Psi\Psi Q} + (\phi_{\Psi\Psi})^2 \phi_{hhQ}}{(\phi_{\Psi\Psi} + \phi_{hh})^2} \quad (2.4.17)$$

#### Remark 11

From Assumption 4 it follows that  $\phi_{\Psi\Psi Q} = \phi_{hhQ} = 0$ . If, on the other hand, the cost of extraction is dependent on the resource stock,  $\phi_{\Psi\Psi Q}$  and  $\phi_{hhQ}$  may be different from zero.

Note that  $\phi_{\Psi\Psi Q}$  and  $\phi_{hhQ}$  may be zero even if the cost of extraction is dependent on the resource stock!



Finally we conclude that  $\partial^2 \lambda_t^* / \partial Q_t^2 = 0$ .

$$\frac{\partial^2 \lambda_t^*}{\partial Q_t \partial h_t} = \left( \frac{1}{(\phi_{\Psi\Psi} + \phi_{hh})^2} \right) \left( (\phi_{hhh} \phi_{\Psi\Psi} + \phi_{hh} \phi_{\Psi\Psi h}) \right. \\ \left. (\phi_{\Psi\Psi} + \phi_{hh}) - (\phi_{hh} \phi_{\Psi\Psi}) (\phi_{\Psi\Psi h} + \phi_{hhh}) \right) \quad (2.4.18)$$

Remark 12

From Assumption 4 follows that  $\phi_{\Psi\Psi h} = 0$ .

Hence, (2.4.18) is equal to (2.4.19)

$$\frac{\partial^2 \lambda_t^*}{\partial Q_t \partial h_t} = \left( \frac{\phi_{\Psi\Psi}}{\phi_{\Psi\Psi} + \phi_{hh}} \right)^2 \phi_{hhh} \quad (2.4.19)$$

$$\frac{\partial^2 \lambda_t^*}{\partial Q_t \partial \Psi_t} = \left( \frac{1}{(\phi_{\Psi\Psi} + \phi_{hh})^2} \right) \left( (\phi_{hh\Psi} \phi_{\Psi\Psi} + \phi_{hh} \phi_{\Psi\Psi\Psi}) \right. \\ \left. (\phi_{\Psi\Psi} + \phi_{hh}) - (\phi_{hh} \phi_{\Psi\Psi}) (\phi_{\Psi\Psi\Psi} + \phi_{hh\Psi}) \right) \quad (2.4.20)$$

Remark 13

From Assumption 4 follows that  $\phi_{hh\Psi} = 0$ .

Hence, (2.4.20) is equal to (2.4.21).

$$\frac{\partial^2 \lambda_t^*}{\partial Q_t \partial \Psi_t} = \left( \frac{\phi_{hh}}{\phi_{\Psi\Psi} + \phi_{hh}} \right)^2 \phi_{\Psi\Psi\Psi} \quad (2.4.21)$$

Finally, there is a possibility to express

$$\frac{\partial \lambda_t^*}{\partial Q_t} \quad \text{explicitly !}$$

(2.4.22) follows from (2.4.15), (Remark 11), (2.4.19), (2.4.21), (2.3.17) and (2.3.19).

$$\frac{\frac{\partial \lambda_t^*}{\partial Q_t}}{\frac{\partial \lambda_t^*}{\partial Q_t}} = \left( \frac{\phi_{\Psi\Psi}}{\phi_{\Psi\Psi} + \phi_{hh}} \right)^2 \phi_{hhh} \left( \frac{\phi_{\Psi\Psi}}{\phi_{\Psi\Psi} + \phi_{hh}} \right) + \left( \frac{\phi_{hh}}{\phi_{\Psi\Psi} + \phi_{hh}} \right)^2 \phi_{\Psi\Psi\Psi} \left( \frac{\phi_{hh}}{\phi_{\Psi\Psi} + \phi_{hh}} \right) \quad (2.4.22)$$

(2.4.22) can be simplified as (2.4.23).

$$\frac{\frac{\partial \lambda_t^*}{\partial Q_t}}{\frac{\partial \lambda_t^*}{\partial Q_t}} = \left( \frac{1}{(\phi_{\Psi\Psi} + \phi_{hh})^3} \right) \left( (\phi_{\Psi\Psi})^3 \phi_{hhh} + (\phi_{hh})^3 \phi_{\Psi\Psi\Psi} \right) \quad (2.4.23)$$

#### Remark 14

From (2.4.23) it is clear that

$$\left. \begin{array}{l} \{ \text{sgn}(\phi_{hhh}) = \text{sgn}(\phi_{\Psi\Psi\Psi}) = \alpha \} \\ \{ \text{sgn}(\phi_{hhh}) = \alpha \quad \phi_{\Psi\Psi\Psi} = 0 \} \\ \{ \phi_{hhh} = 0 \quad \text{sgn}(\phi_{\Psi\Psi\Psi}) = \alpha \} \end{array} \right\} \rightarrow \text{sgn} \left\{ \frac{\frac{\partial \lambda_t^*}{\partial Q_t}}{\frac{\partial \lambda_t^*}{\partial Q_t}} \right\} = \alpha$$

#### Result 2

$\text{sgn}(\beta_2)$  has been determined in the proceeding analysis.

$$\beta_2 = \frac{\frac{\partial \lambda_t^*}{\partial Q_t}}{\frac{\partial \lambda_t^*}{\partial Q_t}} \left\{ \begin{array}{l} > \\ = \\ < \end{array} \right\} 0 \rightarrow \lambda_t^* \text{ is } \left\{ \begin{array}{l} \text{str. convex} \\ \text{linear} \\ \text{str. concave} \end{array} \right\} \text{ in } Q_t$$

Let us reconsider the problem of this section. We wanted to know if the expected marginal present value of the resource saved for the future will increase or decrease under the influence of increasing risk in the process increments. (Recall also Remark 1.)

Now we know that under some assumptions it is possible to determine if  $\lambda_t^*$  is strictly convex, linear or strictly concave in  $p_t$  and  $Q_t$ . The present question is if increasing risk in  $\varepsilon_{t-1}^P$  and/or  $\varepsilon_{t-1}^Q$  (which implies increasing risk in  $P_t$  and  $Q_t$ ) will increase or decrease the expected value of  $\lambda_t^*(= E_{t-1}(\lambda_t^*))$ .

Approximate the continuous distributions  $F(\cdot)$  and  $G(\cdot)$  by discrete distributions with  $n$  prices and quantities. The probabilities of price  $p_i$  and quantity  $Q_j$  are denoted by  $\bar{F}(p_i)$  and  $\bar{G}(Q_j)$  respectively. Again, notation is simplified.

$$\sum_i \bar{F}(p_i) = 1 \quad (2.4.24)$$

$$\sum_j \bar{G}(Q_j) = 1 \quad (2.4.25)$$

The expected marginal value of the resource in period  $t$  is;

$$E_{t-1}(\lambda_t^*) = \sum_i \sum_j \lambda_t^*(p_i, Q_j) \bar{F}(p_i) \bar{G}(Q_j) \quad (2.4.26)$$

A Rothschild/Stiglitz (8) mean preserving spread (MPS) in the variable  $x$  is defined according to (2.4.27).

$$\left\{ \begin{array}{l} dX_A = 0 \text{ for } (A \mid A \neq \alpha, A \neq \beta) \\ - \text{Prob}(X_\alpha) dX_\alpha = \text{Prob}(X_\beta) dX_\beta = k_x > 0 \\ X_\alpha < X_\beta \end{array} \right\} \quad (2.4.27)$$

Let us use the definition (2.4.27) in the analysis of increasing risk in price and quantity!  $k_p$  and  $k_Q$  denote increasing risk in  $P_t$  and  $Q_t$ .

$$\frac{\partial E_{t-1}(\lambda_t^*)}{\partial k_p} = \sum_j \left[ \frac{\partial \lambda_t^*(P_\alpha, Q_j)}{\partial P} \bar{F}(P_\alpha) \frac{\partial P_\alpha}{\partial k_p} + \frac{\partial \lambda_t^*(P_\beta, Q_j)}{\partial P} \bar{F}(P_\beta) \frac{\partial P_\beta}{\partial k_p} \right] \bar{G}(Q_j) \quad (2.4.28)$$

$$\frac{\partial E_{t-1}(\lambda_t^*)}{\partial k_p} = \sum_j \left[ - \frac{\partial \lambda_t^*(P_\alpha, Q_j)}{\partial P} + \frac{\partial \lambda_t^*(P_\beta, Q_j)}{\partial P} \right] \bar{G}(Q_j) \quad (2.4.29)$$

by symmetry, it is clear that;

$$\frac{\partial E_{t-1}(\lambda_t^*)}{\partial k_Q} = \sum_i \left[ - \frac{\partial \lambda_t^*(P_i, Q_\alpha)}{\partial Q} + \frac{\partial \lambda_t^*(P_i, Q_\beta)}{\partial Q} \right] \bar{F}(P_i) \quad (2.4.30)$$

Remark 15

$$\lambda_t^* \left\{ \begin{array}{l} \text{str. convex} \\ \text{linear} \\ \text{str. concave} \end{array} \right\} \text{ in } x_t \rightarrow \frac{\partial E_{t-1}(\lambda_t^*)}{\partial k_x} \left\{ \begin{array}{l} > \\ = \\ < \end{array} \right\} 0$$

Result 3

$\frac{\partial W(P_{t-1}, \Psi_{t-1})}{\partial \Psi_{t-1}}$  is an increasing function of  $E_{t-1}(\lambda_t^*)$ . The effect of increasing risk in  $\epsilon_{t-1}^P$  and  $\epsilon_{t-1}^Q$  on  $E_{t-1}(\lambda_t^*)$  has been analysed. In some cases, the sign of the change in  $E_{t-1}(\lambda_t^*)$  is unambiguous. In table 3 the results are summarized with respect to risk increases in  $\epsilon_{t-1}^Q$ .

Table 3 Changes in  $E_{t-1}(\lambda_t^*)$  when the risk in  $\varepsilon_{t-1}^Q$  increases (see remark 14). A similar table can be constructed for increasing risk in  $\varepsilon_{t-1}^P$ . Then, however,  $\phi_{\Psi P P}$  and  $\phi_{\Psi \Psi P}$  must also be taken into consideration (see remark 10).

$\phi_{hhh}$	$\phi_{\Psi\Psi\Psi}$	Sign of change in $E_{t-1}(\lambda_t^*)$ and $\frac{\partial W_t(P_{t-1}, \Psi_{t-1})}{\partial \Psi_{t-1}}$ when the risk in $\varepsilon_{t-1}^Q$ increases
> 0	> 0	> 0
> 0	= 0	> 0
> 0	< 0	$\begin{matrix} > \\ < \end{matrix} 0 \quad ?$
= 0	> 0	> 0
= 0	= 0	= 0
= 0	< 0	< 0
< 0	> 0	$\begin{matrix} > \\ < \end{matrix} 0 \quad ?$
< 0	= 0	< 0
< 0	< 0	< 0

2.5 Implications of increasing risk in the process increments in the future for the optimal present extraction level

Let us do some comparative static analysis in period  $t$ . We want to know in what direction  $h_t^*$  and  $\lambda_t^*$  will change when the risk increases in  $\varepsilon_t^P$  and/or  $\varepsilon_t^Q$ . Let  $\xi$  denote risk in  $\varepsilon_t^P$  and/or  $\varepsilon_t^Q$ .

$$\begin{bmatrix} D \end{bmatrix} \begin{bmatrix} d\lambda_t^* \\ dh_t^* \\ d\psi_t^* \end{bmatrix} = \begin{bmatrix} 0 \\ 0 \\ -\phi_{\psi\xi} d\xi \end{bmatrix} \quad (2.5.1)$$

$$\frac{\partial \lambda_t^*}{\partial \xi} = \frac{\begin{vmatrix} 0 & -1 & -1 \\ 0 & \phi_{hh} & 0 \\ -\phi_{\psi\xi} & 0 & \phi_{\psi\psi} \end{vmatrix}}{|D|} \quad (2.5.2)$$

$$\frac{\partial \lambda_t^*}{\partial \xi} = \frac{-\phi_{hh}\phi_{\psi\xi}}{|D|} \quad (2.5.3)$$

Remark 16

$$(2.5.3) \rightarrow \left\{ \text{sgn} \left( \frac{\partial \lambda_t^*}{\partial \xi} \right) = \text{sgn} (\phi_{\psi\xi}) \right\}$$

Through induction, it is easily verified that  $\text{sgn} \left( \frac{\partial \lambda_{t-n}^*}{\partial \xi} \right) = \text{sgn} (\phi_{\psi\xi}) \quad n > 0$

Hence, the following induction argument should hold;

1. The expected marginal present value of the resource saved in period  $t$  is  $\phi_{\psi}$ . The risk in  $\epsilon_t^P$  and/or  $\epsilon_t^Q$  increases.
2. We know the signs of  $\phi_{hhh}$  and  $\phi_{\psi\psi\psi}$ . In table 3 it is possible to determine if  $\phi_{\psi}$  increases or decreases (at least in the case of increasing risk in  $\epsilon_t^Q$ ).
3. In remark 16 we observe that  $\lambda_t^*$  increases (is unchanged) (decreases) if  $\phi_{\psi}$  increases (is unchanged) (decreases).

$$\frac{\partial \phi_{t-1}}{\partial \psi_{t-1}} = E_{t-1}(\lambda_t^*) \frac{\partial E_{t-1}(Q_t)}{\partial \psi_{t-1}}$$

Hence, if we assume that  $\frac{\partial E_{t-1}(Q_t)}{\partial \psi_{t-1}} > 0$ , (see remark 4)  $\frac{\partial \phi_{t-1}}{\partial \psi_{t-1}}$

increases (is unchanged) (decreases).

4. From above, it is clear that an increase (no change) (decrease) in  $\frac{\partial \phi_t}{\partial \psi_t}$  implies an increase (no change) (decrease) in  $\frac{\partial \phi_{t-n}}{\partial \psi_{t-n}}$ ,  $n > 0$ .

#### Result 4

An increase (no change) (a decrease) in  $\frac{\partial \phi_t}{\partial \psi_t}$  implies an increase (no change) (a decrease) in  $\frac{\partial \phi_{t-n}}{\partial \psi_{t-n}}$ ,  $n > 0$ . The assumption that  $\phi_{hh} < 0$  is critical to the result.

$$\frac{\partial h_t^*}{\partial \xi} = \frac{\begin{vmatrix} 0 & 0 & -1 \\ -1 & 0 & 0 \\ -1 & -\phi_{\psi\xi} & \phi_{\psi\psi} \end{vmatrix}}{|D|} \quad (2.5.4)$$

$$\frac{\partial h_t^*}{\partial \xi} = \frac{-\phi_{\psi\xi}}{|D|} \quad (2.5.5)$$

#### Result 5

$$\text{sgn} \left( \frac{\partial h_t^*}{\partial \xi} \right) = - \text{sgn} (\phi_{\psi\xi})$$

Hence, from result 4, we observe that the present extraction level  $h_t^*$  should increase (be unchanged) (decrease) if the risk in  $\epsilon_{t+n}^p$  ( $\epsilon_{t+n}^Q$ ) increases and  $\lambda_{t+n}^*$  is strictly concave (linear) (strictly convex) in  $P_{t+n}$  ( $Q_{t+n}$ ). The sign of the second order derivatives of  $\lambda_{t+n}^*$  with respect to  $Q_{t+n}$  can be determined in some cases from the signs of  $\phi_{hhh}$  and  $\phi_{\psi\psi\psi}$  in period  $t+n$ . The sign of the second order derivative of  $\lambda_{t+n}^*$  with respect to  $P_{t+n}$  depends on  $\phi_{hhh}$ ,  $\phi_{\psi\psi\psi}$ ,  $\phi_{\psi\psi p}$  and  $\phi_{\psi\psi p}$  (see table 3).

#### 2.6 Can the signs of $\phi_{hhh}$ and $\phi_{\psi\psi\psi}$ be unambiguously determined?

As we recall from table 3, the signs of  $\phi_{hhh}$  and  $\phi_{\psi\psi\psi}$  must be known in period  $t+1$  if we are interested to know in what direction the optimal

harvest level changes in period  $t-n$ ,  $n > 0$  when the risk increases in  $\epsilon_t^P$  and/or  $\epsilon_t^Q$ .

In this section we will investigate some cases when the signs of  $\phi_{hhh}$  and  $\phi_{\Psi\Psi\Psi}$  can be unambiguously determined in all time periods.

In period  $t$ , we expect the present value of future profits to be equal to  $W_{t+1}(\cdot)$ .

$$W_{t+1}(P_t, \Psi_t) = \iint \max_{Q_{t+1}} \phi_{t+1}(\cdot, P_{t+1}, Q_{t+1}) F'(P_{t+1} | P_t) dP_{t+1} G'(Q_{t+1} | \Psi_t) dQ_{t+1} \quad (2.6.1)$$

(2.6.1) can be replaced by (2.6.2). Some notational simplification will be undertaken.

$$W_{t+1}(P_t, \Psi_t) = \iint \phi^*(\cdot, [E_t(Q_{t+1}(\Psi_t)) + \epsilon_t^Q]) F'(P_{t+1} | P_t) dP_{t+1} G'(\epsilon_t^Q) d\epsilon_t^Q \quad (2.6.2)$$

$$\frac{\partial W_{t+1}(\cdot)}{\partial \Psi_t} = \iint (\phi' Q') \dots \quad (2.6.3)$$

$$\frac{\partial^2 W_{t+1}(\cdot)}{\partial \Psi_t^2} = \iint ((\phi''(Q'))^2 + \phi' Q'') \dots \quad (2.6.4)$$

$$\frac{\partial^3 W_{t+1}(\cdot)}{\partial \Psi_t^3} = \iint (\phi'''(Q')^3 + 3\phi'' Q' Q'' + \phi' Q''') \dots \quad (2.6.5)$$

It should be clear from (2.6.5) that if the expected growth is a linear function of the saved resource quantity ( $+Q' > 0$ ,  $Q'' = 0$ ,  $Q''' = 0$ ), then (2.6.6) holds.

$$\text{sgn} \left( \frac{\partial^3 W_{t+1}}{\partial \Psi_t^3} \right) = \text{sgn} \left( \frac{\partial^3 \phi_{t+1}^*}{\partial Q_{t+1}^3} \right) = \text{sgn} \left( \frac{\partial^2 \lambda_{t+1}^*}{\partial Q_{t+1}^2} \right) \quad (2.6.6)$$



(2.6.6) will hold also if growth is assumed to be a concave function where the third order derivative is nonnegative ( $\rightarrow Q' > 0, Q'' < 0, Q''' > 0$ )

and  $\phi''' > 0$ .

Remark 17

In general, the sign of  $\frac{\partial^3 W_{t+1}}{\partial \Psi_t^3}$  is dependent on the signs and absolute

values of  $\frac{\partial \phi_{t+1}^*}{\partial Q_{t+1}}$ ,  $\frac{\partial^2 \phi_{t+1}^*}{\partial Q_{t+1}^2}$ ,  $\frac{\partial^3 \phi_{t+1}^*}{\partial Q_{t+1}^3}$ ,  $\frac{\partial E_t(Q_{t+1})}{\partial \Psi_t}$ ,  $\frac{\partial^2 E_t(Q_{t+1})}{\partial \Psi_t^2}$  and  $\frac{\partial^3 E_t(Q_{t+1})}{\partial \Psi_t^3}$

The sign can be determined through (2.6.5).

Now, the method of induction will be used to show that the signs of  $\phi_{hhh}$  and  $\phi_{\Psi\Psi\Psi}$  can be determined in all time periods if some conditions are satisfied.

Stage	Assumption	Result	Remark
a <sub>1</sub>	$\phi_T(\cdot, Q_T) \equiv V_T(P_T, Q_T)$		since no quantity can be saved until T+1
b <sub>1</sub>		$\text{sgn} \left( \frac{\partial^3 W_T}{\partial \psi_{T-1}^3} \right) = \text{sgn} \left( \frac{\partial^3 \phi_T^*}{\partial Q_T^3} \right)$	Depends on the growth function and $\phi(\cdot)$ see (2.6.5) and remark 17
c <sub>1</sub>		$\text{sgn} \left( \frac{\partial^3 V_{T-1}}{\partial h_{T-1}^3} \right) = \text{sgn} \left( \frac{\partial^3 \phi_T^*}{\partial Q_T^3} \right)$	Follows from the assumption that $\text{sgn}(V_T^i) = \alpha_i$ for all t and $\phi_T \equiv V_T$
d <sub>1</sub>		$\text{sgn} \left( \frac{\partial^3 \phi_{T-1}^*}{\partial Q_{T-1}^3} \right) = \text{sgn} \left( \frac{\partial^3 \phi_T^*}{\partial Q_T^3} \right)$	Follows from b <sub>1</sub> , c <sub>1</sub> , (2.4.23)
b <sub>2</sub>		$\text{sgn} \left( \frac{\partial^3 W_{T-1}}{\partial \psi_{T-2}^3} \right) = \text{sgn} \left( \frac{\partial^3 \phi_{T-1}^*}{\partial Q_{T-1}^3} \right)$	As in b <sub>1</sub>

Stage	Assumption	Result	Remark
$c_2$	$\text{sgn} \left( \frac{\partial^3 V_{T-2}}{\partial h^3_{T-2}} \right) = \text{sgn} \left( \frac{\partial^3 \phi_{T-1}^*}{\partial Q^3_{T-1}} \right)$		since $\phi_T \equiv V_T$ and from $d_1$
$d_2$		$\text{sgn} \left( \frac{\partial^3 \phi_{T-2}^*}{\partial Q^3_{T-2}} \right) = \text{sgn} \left( \frac{\partial^3 \phi_T^*}{\partial Q^3_T} \right)$	Follows from $b_2,$ $c_2,$ (2.4.23)
.....			
.....			
.....			
$b_{i+1}$	$\text{sgn} \left( \frac{\partial^3 W_{T-i}}{\partial \psi^3_{T-1-i}} \right) = \text{sgn} \left( \frac{\partial^3 \phi_{T-i}^*}{\partial Q^3_{T+1-i}} \right)$		as in $b_1$
$c_{i+1}$	$\text{sgn} \left( \frac{\partial^3 V_{T-1-i}}{\partial h^3_{T-1-i}} \right) = \text{sgn} \left( \frac{\partial^3 \phi_{T-i}^*}{\partial Q^3_{T-i}} \right)$		since $\phi_T \equiv V_t$ and from $d_i$
$d_{i+1}$		$\text{sgn} \left( \frac{\partial^3 \phi_{T-1-i}^*}{\partial Q^3_{T-1-i}} \right) = \text{sgn} \left( \frac{\partial^3 \phi_T^*}{\partial Q^3_T} \right)$	Follows from $b_{i+1}, c_{i+1},$ (2.4.23)

Remark 18

If the assumptions  $a_i, b_i, c_i$  are valid for all  $i$ , then the signs of  $\phi_{hhh}$  and  $\phi_{\psi\psi\psi}$  can be unambiguously determined in all time periods.

## 2.7 An example

In order to illustrate the use of the results in sections 2.1-2.6, we consider the following situation. The profit from extraction is defined in (2.7.1), the growth process in (2.7.2) and the price process in (2.7.3)

$$V_t(P_t, h_t) = P_t h_t - k(t) h_t^{(1+\alpha(t))}, \begin{pmatrix} 0 < \alpha(t) < 1 \\ 0 < k(t) \end{pmatrix} \quad (2.7.1)$$

$$Q_{t+1} = c(t) + \beta(t) \ln(\Psi_t) + \varepsilon_t^Q \quad (0 < \beta(t)) \quad (2.7.2)$$

$$P_{t+1} = a(t) + b(t) P_t + \varepsilon_t^P, \quad \begin{pmatrix} 0 < b(t) < 1 \\ 0 < a(t) \end{pmatrix} \quad (2.7.3)$$

From (2.7.1), (2.7.2) and (2.7.3), we extract the following derivatives and signs;

$$\begin{aligned} \phi_h &> 0 \quad (\text{Assumption}) & Q'' &< 0 \\ \phi_{hh} &< 0 & Q''' &> 0 \\ \phi_{hhh} &> 0 & P' (= \frac{\partial P_{t+1}}{\partial P_t}) &= b(t) \quad (2.7.4) \\ Q' (= \frac{\partial Q_{t+1}}{\partial Q_t}) &> 0 & 0 &< P' < 1 \end{aligned}$$

The analysis is made in the following order;

1. Through induction we can verify that  $\phi_{hhh} > 0$  and  $\phi_{\Psi\Psi\Psi} > 0$  in all time periods (see section 2.6).
2.  $E_{t-1}(\lambda_t^*)$  is strictly convex in  $\varepsilon_t^Q$  for all  $t$  such that  $t < T$  (see (2.4.12), (2.4.23), remark 10 and remark 14).
3. Increasing risk in  $\varepsilon_t^Q$  increases  $E_{t-1}(\lambda_t^*)$  for all values of  $P_{t-1}$  and  $\Psi_{t-1}$  (see remark 15).
4.  $h_{t-n}^*$  decreases and  $\lambda_{t-n}^*$  increases for all  $n > 1$  (see section 2.5).

Hence, in this case, increasing risk with unchanged expectation in the growth process during some future period  $t$  ( $t < T$ ) implies that the present extraction level should decrease. The other result is that the expected marginal present value of the resource increases. Both effects are unambiguous.

If  $b(t) = 0$  or it can be shown that  $\phi_{\psi p}$  and  $\phi_{\psi \psi}$  are close to zero, then increasing risk in the increments of the price process some time in the future ( $\varepsilon_t^p$ ) implies that the present extraction level should decrease and that the expected marginal present value of the resource increases.

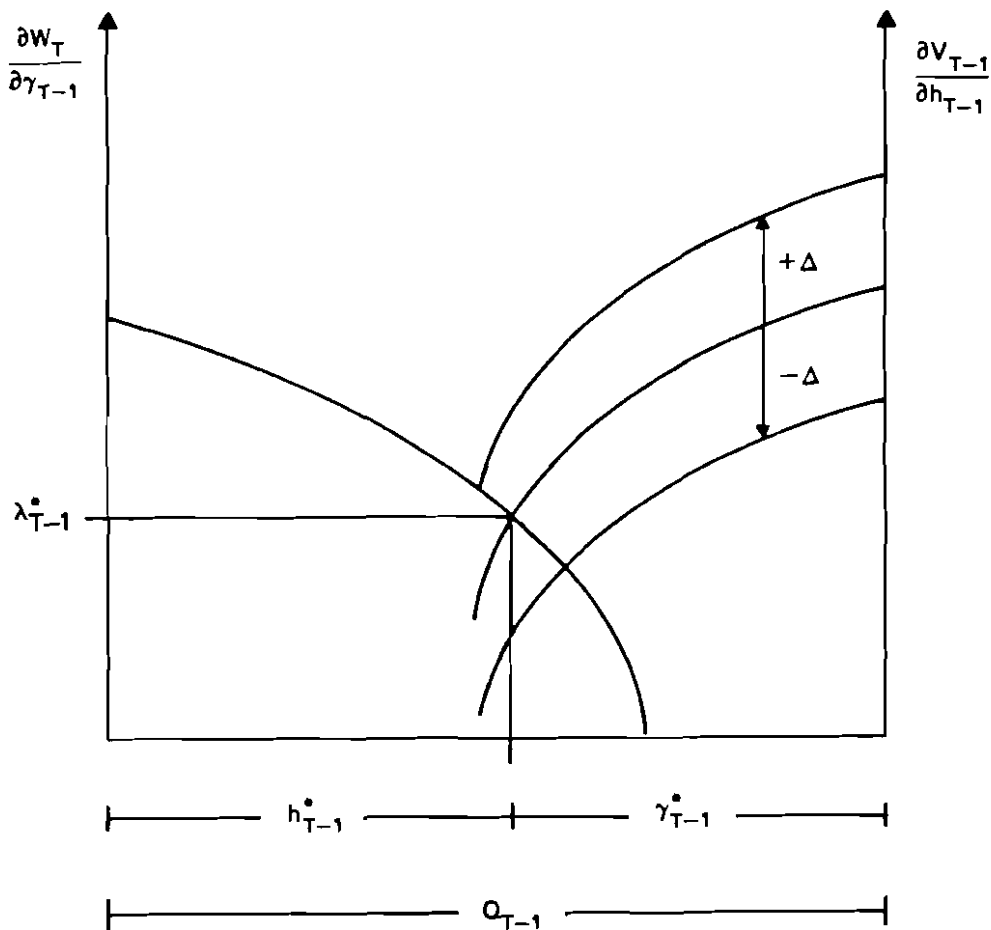

Figure 5.1 Increasing risk in the price in the last period ( $T$ ) does not affect  $h_{T-1}^*$  or  $\lambda_{T-1}^*$ . The reason is that the expected marginal value of the resource  $E_{T-1}(\lambda_T^*)$  is independent of the price risk



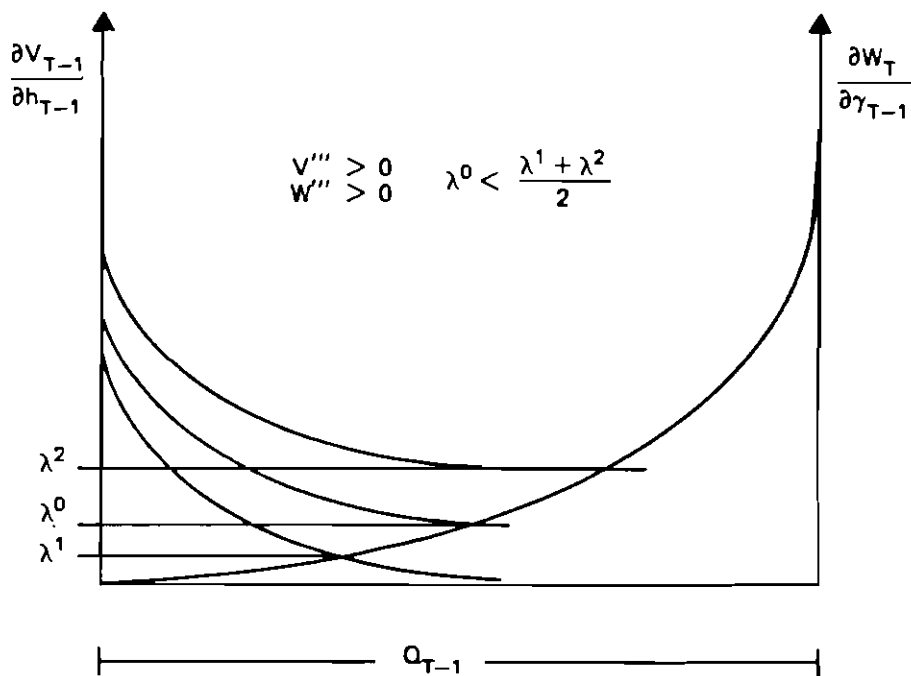

Figure 5.3 a Exactly as figure 5.2 a except for that  $V''' > 0, W''' > 0$ .

Here,  $E_{T-2}^*(\lambda_{T-1}^*)$  increases as the price risk in period T-1 increases (see (2.4.12) and figure 5.3 b!)

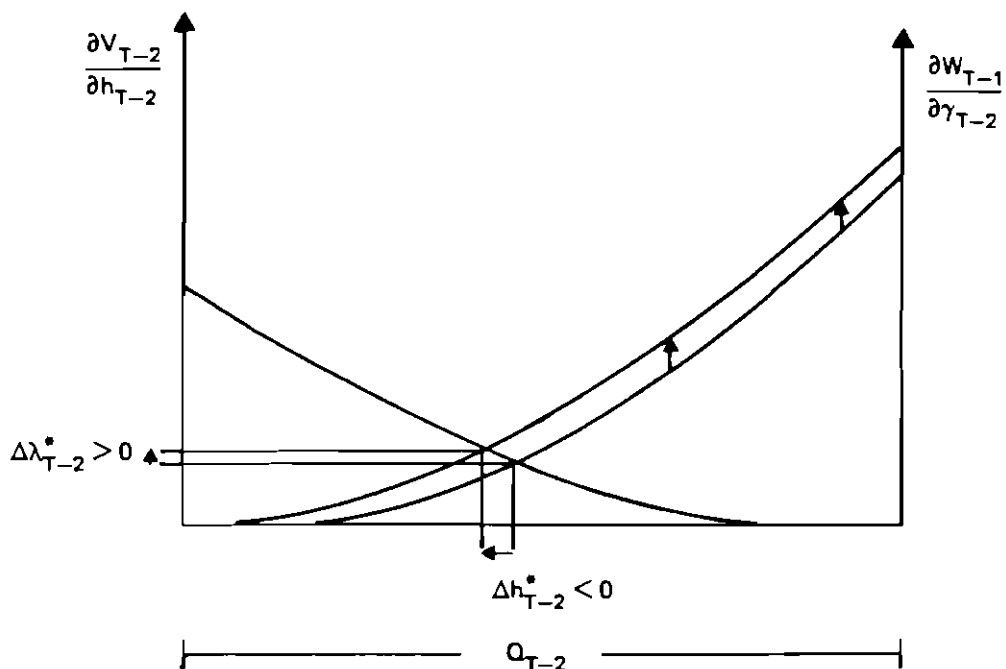

Figure 5.3 b In figure 5.3 a we obtained an increase in  $E_{T-2}^*(\lambda_{T-1}^*)$ .

This, in turn, implies an increase in  $\frac{\partial W_{T-1}}{\partial \gamma_{T-2}}$ , which is

illustrated above. Hence,  $\lambda_{T-2}^*$  will increase and  $h_{T-2}^*$  will decrease.

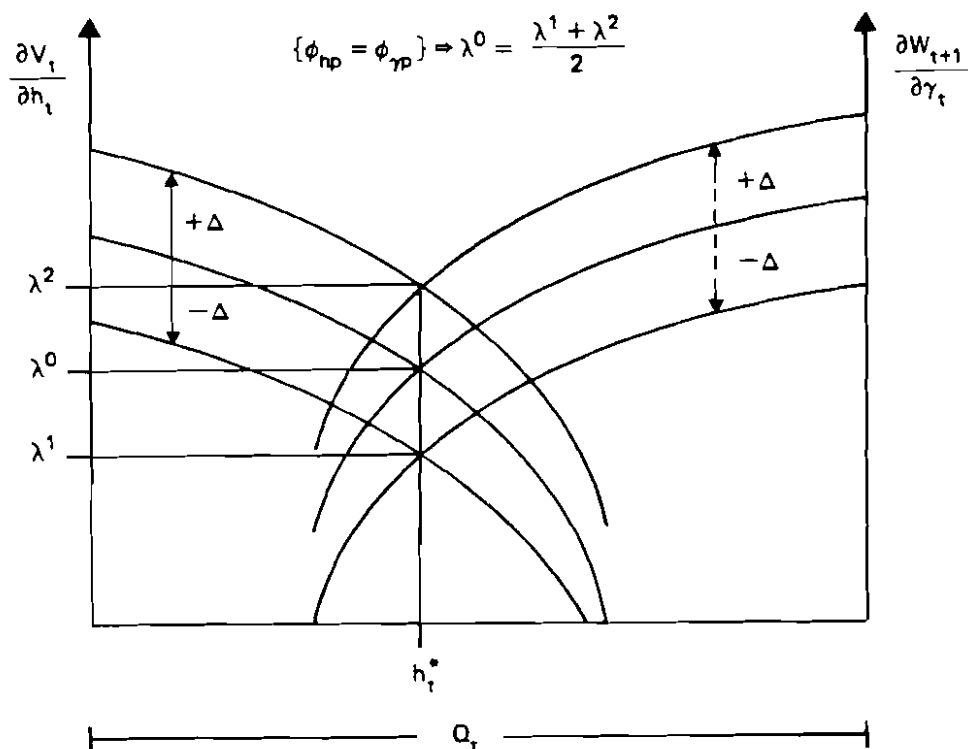

Figure 5.4 Let us assume that  $\phi_{hp} = \phi_{\psi p}$ . A change in the price in period  $t$  will then not affect the optimal harvest level since the expected marginal profit from the saved resource changes equally much. This, in turn, implies that  $E_{t-1}(\lambda_t^*)$  is unaffected by increasing risk in  $P_t$ , and  $h_{t-n}^*$  ( $n > 1$ ) will not change. (See remark 3.)

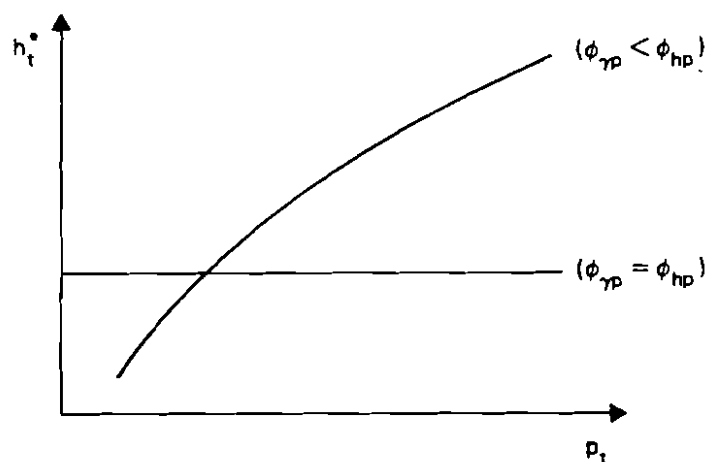

Figure 5.5 Optimal present harvest level as a function of the present price. (See remark 3 and figure 5.4.)



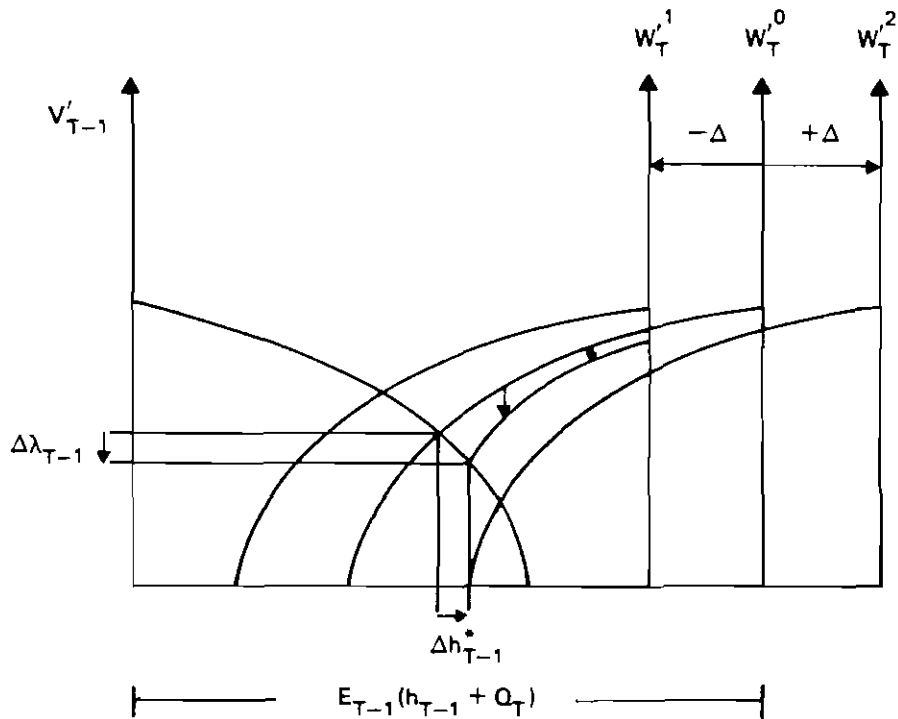

Figure 5.6 Increasing risk in the linear growth process ( $\varepsilon_{T-1}^Q$ )  $Q_T = c(Q_{T-1} - h_{T-1}) + \varepsilon_{T-1}^Q$  is illustrated above. The risk increase implies that  $h_{T-1}^*$  increases. Since  $E_{T-2}(\lambda_{T-1}^*)$  decreases,  $h_{T-n}^*$  ( $n > 1$ ) increases. A critical assumption is that  $V''' < 0$ ,  $W''' < 0$  (see table 3).

### 3 Discussion

The problem under investigation is fairly general. Still, some rather strong results have been obtained.

As can be seen in the example of section 2.7, the effect of increasing risk some time in the future in the price and/or the growth process ( $\varepsilon_t^P, \varepsilon_t^Q$  such that  $t < (T-1)$ ) on the optimal present extraction level is unambiguously negative. Note that the set of unambiguously determined derivatives in (2.7.4) can be obtained from a large set of assumptions concerning the stochastic processes and the cost function. Furthermore, many other combinations of derivatives and signs give unambiguous results. One such example is;

$$\begin{aligned}
 V_t &= P_t h_t - C_t(h_t) \\
 Q_{t+1} &= c(t) + \beta(t)\Psi_t + \varepsilon_t^Q & (0 < \beta(t)) & \quad (3.1) \\
 P_{t+1} &= a(t) + b(t)P_t + \varepsilon_t^P & \begin{array}{l} 0 < a(t) \\ 0 < b(t) < 1 \end{array} &
 \end{aligned}$$

Here, we assume density independent (but possibly time dependent) growth and a stationary first order auto regressive price process (with possibly time dependent parameters).

The assumptions should be realistic in for instance the oil, coal and mineral sectors (if price is stationary) since these resources generally have no growth at all. If we make use of the methodology described in section 2.7, we will find that the present extraction level should increase (be unchanged) (decrease) if the risk increases in the price and/or the growth process some time in the future ( $\varepsilon_t^P, \varepsilon_t^Q$  such that  $t < (T-1)$ ) and the marginal cost function is progressive (linear) (regressive).

(It is important to be aware of the discussion in the end of section 2.7.)

The question of how the stochastic component should enter the growth process has been discussed by May, Beddington, Harwood and Shepherd. The main question is whether or not the risk (or uncertainty) is density dependent. They state that the optimal harvesting decision is dependent on that.

Obviously, this is true. Under the assumption of density dependent risk, the risk is no longer exogenous to the enterprise. The risk can be affected through the harvest level. However, they also write that there are arguments why it is likely for environmental unpredictability to be associated predominantly with density independent, rather than density dependent, population processes. (Also in the study by Doubleday (3), the noise is independent of population size.)

4 References

- (1) Bellman, R: Dynamic Programming, Princeton, N.J., Princeton University Press, 1957
- (2) Chow, G. C: Optimum control of stochastic differential equation systems, Journal of Economic Dynamics and Control, 1, 143-175, 1979
- (3) Doubleday, W. G: Environmental fluctuations and fisheries management, Int. Comm. Northw. Atlant. Fish. Sel. Pap. 1:141-150, 1976
- (4) Fleming, W. H. & Rishel, R. W: Deterministic and Stochastic Optimal Control, Springer-Verlag, 1975
- (5) Gleit, A: Optimal harvesting in continuous time with stochastic growth, Mathematical Biosciences 41, 111-123, 1978
- (6) Ito, K. & McKean, H. P. Jr: Diffusion Processes and their sample paths, Academic Press, New York, 1964
- (7) May, R. M., Beddington, J. R., Harwood, J. W. & Shepherd, J. G: Exploiting Natural Populations in an uncertain world, Mathematical Biosciences 42, 219-252, 1978
- (8) Rothschild, M. & Stiglitz, J: Increasing risk: I. A definition, Journal of Economic Theory, 2, 225-243, 1970