

STABLE MANIFOLDS AND SEPARATRICES

H. R. Grüm

October 1975

WP-75-139

Working Papers are not intended for distribution outside of IIASA, and are solely for discussion and information purposes. The views expressed are those of the author, and do not necessarily reflect those of IIASA.

Stable Manifolds and Separatrices

by H.R. Grüm

1. Introduction

In the last weeks, many people at IIASA have been concerned with the concept of resilience, after initial work in this direction by C.S. Holling /1/. He talked about resilience as a "measure of the ability of systems to absorb change of state variables, driving variables and parameters and still persist ". In my opinion, resilience, thus defined, is directly related to a) the basins of attraction of the system and b) their changes under variations of external parameters. i.e. variations in the time-evolution laws of the system. If one changes the state variables (= the point in phase space describing the system at a given time) but still remains within the same basin, the asymptotic behaviour of the system will not change. (This can be made rigorous by a recent theorem of Ruelle and Bowen /2/). If the dynamics of the system are changed a little, the boundaries of the basins (the separatrices) might move only a little and the structure of the attractors within them might remain the same, such that a point would still trace out a trajectory of the same nature as before the change under the new dynamic laws. On the contrary crossing a separatrix will lead to drastic and catastrophic

changes in the long-time behaviour of the system, as illustrated in the recent model of Häfele /3/. Häfele proposed therefore that the distance from the next separatrix should be put into a measure of resilience. It is the purpose of this paper to discuss the nature of these separatrices and illustrate their properties in a simple model.

2. The General Connection Between Stable Manifolds and Separatrices.

(For the concepts of differentiable dynamics occurring here see a forthcoming Internal Report).

We take a system described by points in some manifold M of dimension n whose time evolution is governed by a set of differential equations. They define a one-parameter group (we forget the well-known problems of incompleteness, i.e. reaching the infinite or some singularity in a finite time) giving for each initial state $X \in M$ the state $\phi_t(X)$ after some time t . We assume for simplicity Axiom A^{*}, in order to be able to define stable and instable manifolds very easily. The non-wandering set Λ (the set of critical elements in the phase space of the system) is therefore divided into invariant basic sets Λ_i . For the moment we assume that all Λ_i 's are manifolds, e.g. stationary points, closed orbits, invariant tori, etc. The stable and unstable manifolds $W^S(\Lambda_i)$ and

$W^u(\Lambda_i)$ are defined as the set of points going to Λ_i in the future resp. coming from Λ_i in the past:

$$W^s(\Lambda_i) = \{x \in M \mid \phi_t(x) \rightarrow \Lambda_i \text{ as } t \rightarrow +\infty\}$$

$$W^u(\Lambda_i) = \{x \in M \mid \phi_t(x) \rightarrow \Lambda_i \text{ as } t \rightarrow -\infty\}$$

They are smooth sub-manifolds invariant under time-evolution whose dimensions add up to n plus the dimension of Λ_i . The attractors of the system are singled out among the Λ_i 's by the fact that their stable manifold is open and has therefore the dimension of the whole phase space, here W^s is nothing but the basin or domain of attraction. These attractors describe the possible modes of stable long-time behaviour of the system, in the sense that this behaviour does not depend on infinitesimal changes in the initial conditions. Such a dependency would be unsuitable e.g. in ecological considerations, where the state of the system at present is known only approximately. Their boundaries are exactly the stable manifolds of dimension $n-1$ (e.g. originating from a saddle point with $n-1$ stable directions or from a closed orbit with $n-2$ stable directions) which can be identified with the separatrices. We might talk about "almost attractors". These separatrices are invariant, so without perturbation the system cannot cross them. When the system under some perturbations crosses the separatrices, it moves into another basin and its long-range behaviour changes drastically,

like in Häfele's example (Separatrix S_2). For completeness, one might add that, in the case of a non-compact phase space, there will be some "basins leading to infinity". (All phase space in Häfele's example except for S_1 and S_2). Here the unstable manifolds (separatrix S_1) can be used to describe asymptotic tendencies, since the trajectories tend to approach them ²⁾. By a suitable compactification of phase space, one can attach an attracting fixed point to these unstable manifolds, though this procedure is rather artificial.

Under the stated assumptions, we can therefore set up a four-stage-concept for measuring resilience:

1. Find the attractors
2. Find the "almost attractors" in the sense of the basic sets with stable manifolds of dimension $n-1$.
3. These stable manifolds are the separatrices, dividing up the whole phase space into open basins, each one for an attractor.
4. Put the distance from the next separatrix into a suitable quantitative measure for resilience.

Numerical methods for steps 1)-2) are numerous in the case of fixed points. For the general case, and for finding the corresponding separatrices, they are being developed by R. Bowen (K. Sigmund, oral communication), H. Scarf and the author.

2) One has to keep in mind that points close to, but not on a stable manifold move away from it, close to an unstable manifold towards it.

This clear-cut picture might be obscured by two difficulties:

1. Some "almost attracting" basic sets might not be manifolds. Example: Smale's horseshoe. In this case, it is still possible to define stable manifolds for them, but their structure will be much more complicated.
2. Stable manifolds of well-behaved basic sets may behave quite erratically in the large due to heteroclinic or homoclinic points. It is very improbable for these pathological cases to occur in simple few parameter models, although one should be aware of their possible existence.

3. A Simple illustrating model

I take a simple three-dimensional model in order to illustrate the concepts and relationships of section 2., since the phenomenon of separatrices originating from closed orbits occurs only in dimensions 3. For simplicity, the equations are written down in cylindrical coordinates:

$$\begin{aligned}\dot{r} &= -r + \alpha^2 r^3 \\ \dot{z} &= z(1 - 4\alpha^2 r^2) - \beta^2 z^3 \\ \dot{\phi} &= r\end{aligned}$$

α and β are given numbers. The non-wandering set of these equations consists of 3 stationary points P_0 , P_+ and P_- at $r=0$ and z at 0 , $\frac{1}{\beta}$, $-\frac{1}{\beta}$ resp. and a closed orbit at $z=0$ and $r = \frac{1}{\alpha}$. A local linear analysis determines the stability character of these critical elements.

P_+ and P_- are stable, so they have an open domain of attraction. P_0 is stable in the (r, ϕ) -plane but unstable in the z -direction; $\dim W^S(P_0) = 2$, so $W^S(P_0)$ is a separatrix. A cross-section to the closed orbit γ is stable in the z -direction, but unstable in the r -direction. Without solving the equations analytically or numerically, we can put down all interesting manifolds:

$$\text{basin of } P_+ = W^S(P_+) = \{(r, z, \phi) \mid r < \frac{1}{\alpha}, z > 0\}$$

$$\text{basin of } P_- = W^S(P_-) = \{(r, z, \phi) \mid r < \frac{1}{\alpha}, z < 0\}$$

$$W^S(P_0) = \{(r, z, \phi) \mid r < \frac{1}{\alpha}, z = 0\}$$

$$W^S(\gamma) = \{(r, z, \phi) \mid r = \frac{1}{\alpha}\}$$

$$W^u(\gamma) = \{(r, z, \phi) \mid z=0, 0 < r < \infty\}$$

$W^S(P_0)$ and $W^S(\gamma)$ are the separatrices. We have three basins $W^S(P_+)$, $W^S(P_-)$ and the "basin of infinity": the part of phase space outside of the cylinder $W^S(\gamma)$ where all trajectories approach $z=0$ but describe larger and larger spirals. $W^u(\gamma)$ is

interesting, too, because the trajectories in the basin of infinity tend to approach it, as was remarked in Section 2. A sketch of the situation is included in the paper. One can visualize the flow within the top half cylinder, e.g. by noting that it is always directed inwards ($\dot{r} < 0$) and in generally, downwards ($\dot{z} < 0$) except within the ellipsoid $4\alpha^2 r^2 + \beta^2 z^2 = 1$.

One should observe that this model is structurally unstable, i.e. the following can happen: under a small change in the differential equations the separatrices in general will perform sudden jumps. Example: make $\dot{z} > 0$ instead of $= 0$ (still independent of ϕ) in a small neighbourhood of the circle $Z=0$, $r = \frac{3}{4\alpha}$ so that trajectories can cross the plane $Z=0$ close to this circle. This will not change the critical elements, but the separatrix $W^S(P_0)$ will turn downwards and approach the cylinder $\{r = \frac{1}{\alpha}\}$ as $Z \rightarrow \cdot \infty$. So points far from the unperturbed basin of $P+$ will suddenly go to $P+$ as $t \rightarrow +\infty$. This instability is due to the fact that $W^S(P_0) \subsetneq W^u(\gamma)$ (non-transversality); intuitively speaking, this is a "coincidence" which can be broken by arbitrarily small changes. One can stabilize the situation by putting:

$$\dot{z} = z \left(1 - \frac{\alpha^2}{4} r^2 \right) - \beta^2 z^3$$

in the defining equations. The ellipsoid $\dot{z} = 0$ will now

intersect the cylinder $\{r = \frac{1}{\alpha} \text{ at } z = \pm \frac{3}{4\beta}\}$ and create two closed orbits γ_{\pm} there; the closed orbit γ at $z = 0$ will now become completely unstable in the sense that $W^u(\gamma)$ is open. The separatrices and basins remain as before but the new model will be structurally stable as $W^s(P_0)$ will now approach even after a perturbation. (The cylinder is still a separatrix, now consisting of $W^s(\gamma_+)$ and $W^s(\gamma_-)$).

4. Possible lines of further thought.

a) In the case of Morse-Smale-flows like in the "stabilized" model (the non-wandering set consists of a finite number of fixed points and closed orbits, plus transversality and hyperbolicity: two technical conditions ³⁾) the system is structurally stable, i.e. the structure of basins and separatrices will not change if one has to chosen on inexact model, due to incomplete knowledge of the real system. On the other hand, structural instability as in the model can occur for all systems in a open set of some parameter space.

b) Catastrophe theory might be applied to determine the surfaces in the space of parameters of the model equations along which structural changes (from structural stability to instability or changes in the location and nature of critical elements) occur. For example, the splitting of γ , γ_+ and γ_- occurs along a fold

3) Well not so technical: lack of transversality e.g. destroys the structural stability of the first model!

(one of the elementary catastrophes of Thom-Zeeman) in the α - β plane.

c) The behaviour of separatrices in the neighbourhood of other critical elements should be investigated, in connection with the definition of a resilience measure as target function in an optimization problem. One should be aware of the possible occurrence of the following situation, already in two dimensions:

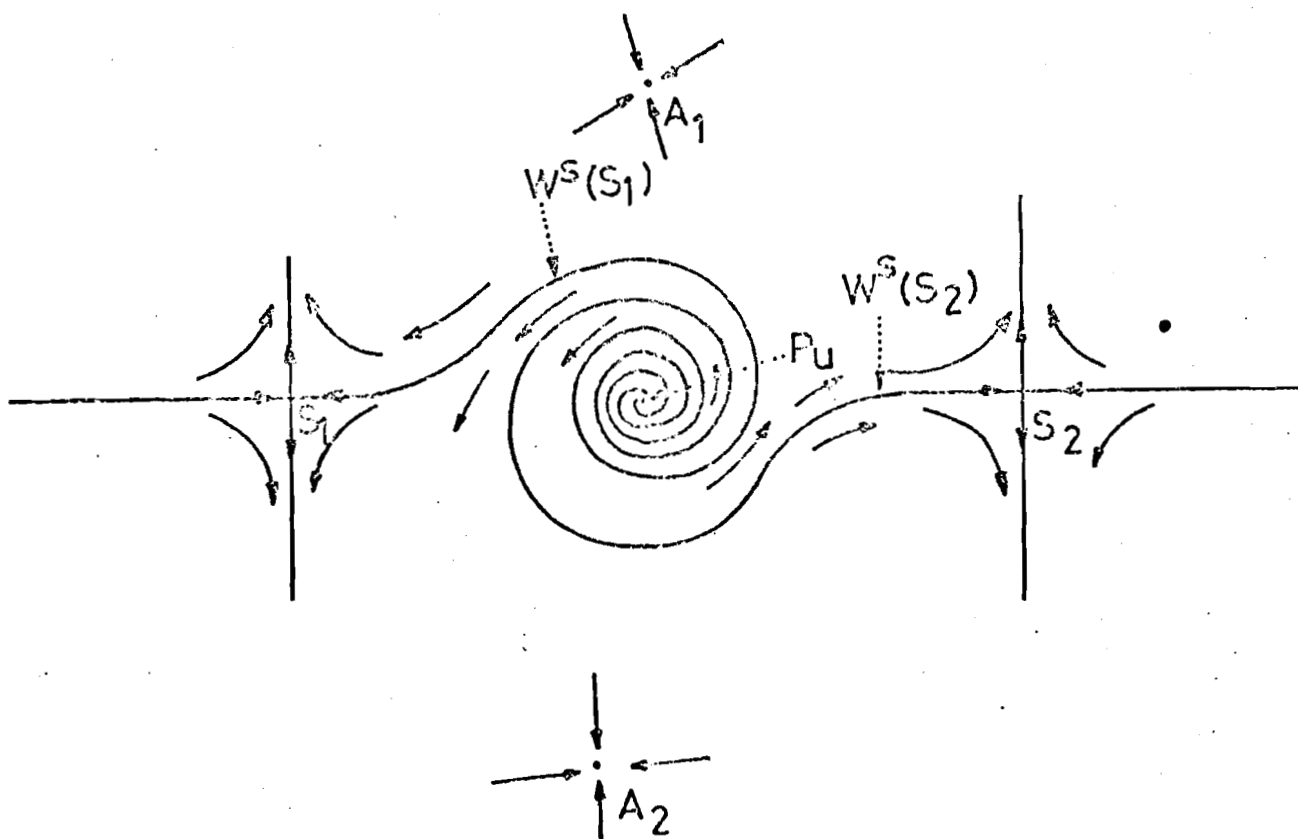

A_1 , A_2 are attractors, S_1 and S_2 saddles and P_u an instable fixed point. The separatrices $W^S(S_1)$ and $W^S(S_2)$ wrap around P_u infinitely often and so the basins of A_1 and A_2 are completely intermeshed.

d) The actual calculation of the separatrix poses certain difficulties since being on a separatrix is a non-local condition for a point. A method that has been applied successfully in a model /4/ consists in starting at the basic set and following the trajectories going in the stable directions backwards in time, for instance by numerical integration. (Figure 2)

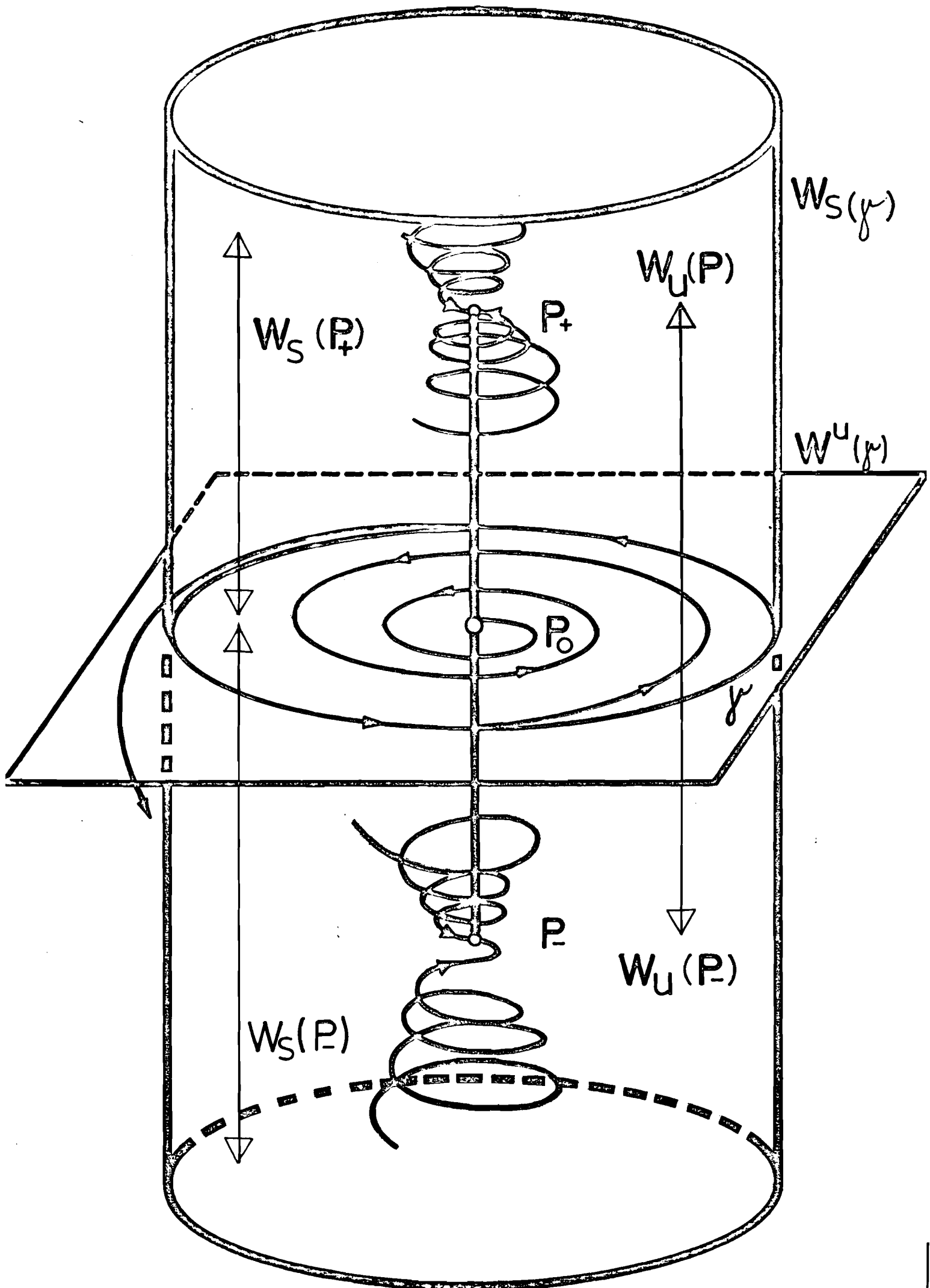

References

- /1/ Holling C.S., "Resilience and Stability of Ecological Systems, IIASA Report
- /2/ Ruelle D., Bowen R., "Ergodic Theory for Axiom A Flows" IHES preprint.
- /3/ Hafele W., "Objective functions" (Festschrift für K. Wirtz)
- /4/ New Societal Equations, app.III., IIASA WP 75-67.