

ON MODELLING AND PLANNING OF OPTIMUM LONG-RANGE
REGIONAL DEVELOPMENT

R. Kulikowski and P. Korcelli

January 1976

WP-76-4

Working Papers are internal publications intended for circulation within the Institute only. Opinions or views contained herein are solely those of the authors.

List of Contents

- I. Policies and Concepts of Regional Development
- II. The National Model
- III. Optimization of Regional Development
- IV. Optimization of Regional Allocation of Production
- V. Modelling the Spatial Allocation Patterns
- VI. Spatial Interaction Modelling on an Interregional
Scale
- VII. Conclusions

On Modelling and Planning of Optimum Long-Range
Regional Development

R. Kulikowski & P. Korcelli

I. Policies and Concepts of Regional Development

It may be assumed that the primary goal of regional policy is to contribute to the national economic and social development (Granberg, 1973). Such an approach basically differs from the concept which emphasizes the development of lagging regions, although the latter's major objective is also included in the former, more comprehensive framework.

When speaking about regional development policies, it is conventional to refer to certain basic alternatives which the analyst, the planner, and the decision maker face. J. Cumberland (1973), for example, formulated some of these alternatives as:

- 1) spatially uniform allocation of economic activity versus maximum production efficiency;
- 2) relocation of persons versus relocation of jobs;
- 3) transformation and subsequent reclamation versus protection of natural environment.

These alternatives may, to a certain extent, reflect the differences between short-range and long-range strategies. In a long-range approach some of them are ruled out since the emphasis has to be put on the rational utilization of all resources available within individual regions, including natural and human resources (see O. Kudinov, 1975). It may be conceived that at each development stage a certain strategy may be regarded as optimal. At present consider a strategy that ensures:

- 1) a high rate of national economic growth;
- 2) equalization of living standards, both between and within regions;

3) protection and enhancement of man's environment.

To make these goals compatible, it is necessary to consider various forms of income transfers between regions and the existence of rigorous environmental policies.

There are a number of theoretical concepts pertaining to the spatial structure of the economy and its change. They range from positive to normative approaches, although all of them carry some policy and planning implications. On the other hand, it is generally acknowledged that a comprehensive theory of space economy is still to be developed.

Among the existing approaches, the location theory (Isard, 1956) has been judged to be rather irrelevant as an explanatory and predictive tool for regional economic growth policy formulations (Thomas, 1972). Its major pitfalls include a static or comparative static framework used and a lack of comprehensive treatment of all sectors of the economy. There are further limitations in the location theory from the perspective of centrally planned economies. Nevertheless, some of the basic notions, such as the functional hierarchy of urban places, have to be taken into account in the planning process. The same is true of the comparative costs analysis which stems from the classical location theory.

The export base theory (Tiebout, 1962) explains some of the facets of regional economic growth, but it is also unable to provide comprehensive guidelines for regional policies. The theory concentrates mainly on one, although a rather crucial aspect of regional structure and growth and it helps to interpret the role of interregional specialization which may or may not be dependent upon interregional differences in natural resource endowment.

Much of the recent theoretical thinking has stemmed from the growth pole concept whose major advantage is an explicitly dynamic character. Although the concept says little about the optimum distribution of economic activity which would

allow to generate a particular rate of economic growth for a region (Thomas, 1972), it sets down some basic requirements for the growth to occur and as such has been used in regional policy formulations. It has been proposed that the growth pole idea in a spatial setting finds a conceptual basis in the spatial diffusion theory (Hägerstrand, 1952). According to this approach, growth occurs as a consequence of the filtering of innovations downwards through the urban hierarchy (Berry, 1972). T. Hermansen (1972) noted that the growth pole concept implies a heavy use of the input-output apparatus (although the input-output bias was less evident in the original formulations) and that the backward and forward linkage effects are closely related to the notion of key industries.

From a regional planning perspective, one of the important questions relates to spatial concentration and deconcentration forces. The concepts reviewed so far can give rise to somewhat contrasting interpretations of that problem. Thus according to M.M. Webber (1972), if the factor of uncertainty is added to the traditional location theory, the resulting locational decisions are likely to favour a higher degree of concentration of economic activity. Within the framework of the growth pole theory (Hermansen, 1972), some authors (i.e. Myrdal) would see the increasing dominance of polarization forces, others (Hirschmann) the eventual ascendancy of spread forces, while still others (Lasuen) a growing stability of spatial patterns over time.

The industrial complex analysis is one of those concepts pertaining to the spatial structure of the economy which are of a strongly normative character and, at the same time, have been extensively used in the planning process. The concept is based on technological, as well as economical linkages, external economy considerations and spatial diffusion mechanisms. By its very nature, it is primarily suited to

centrally planned economies (Probst, 1964), although its universal applicability has been proved (Isard, Schooler, Vietorisz, 1959; J. Paelinck, 1972).

A still more general concept is that of territorial-production complexes (Bandman, 1973; Ekonomiko-geograficheskoye problemy, 1974). In addition to interindustry linkages, it considers the interactions between production and service establishments, as well as the household sector. The models of territorial-production complexes are of a multi-level structure and they generate optimum proportions and distributions of production, service, and residential activities.

As it was emphasized at the outset, in the constructing of regional development programs and models, it is convenient to start from the national level and progress down the hierarchy of spatial scales. This paper will explore the means and methods of disaggregating a national economic development model and, in a later section, the possibilities of using the outputs of regional models in building models of regional spatial structure. Hence, the suggested range of spatial scales extends from national to intraregional. An essential advantage of such an approach is to establish linkages between the various types of models. It has been frequently noted, for example, that spatial interaction models fail to account for feedbacks between the exogenous and the endogenous sectors. By linking these models to regional economic development models, it becomes possible to model the size, composition, and the distribution of the basic sector. Such an approach has been, in fact, proposed by several authors, notably A. Wilson (1974). A sequence of spatial scales, when applied in modelling, may also allow to establish more immediate links between economic and spatial planning.

It is intended that the models discussed below are used in the analysis and planning of economic and social development

in the region of Lublin. In this case the development of major coal resources may be regarded as an exogenous factor whose impacts are to be anticipated and traced through the national, regional, as well as intraregional scale.

II. The National Model

Much has been written on the long-term planning by using normative models of national development. In particular, in [15, 16, 17] a long-term model of national development of Poland (MRI) has been described. The model can be used for the optimization of allocation of resources (capital, labour and government expenditures) among the production, consumption and environment sectors.

In the present paper we shall show how the national core model (such as MRI) can be used for optimum allocation of resources among the different regions of the country.

Let us start with a short description of the national model. The production subsystem consists of n sectors S_i , $i = 1, \dots, n$, shown in Figure 1, each described by the production function

$$X_{ii} = F_i q_i \prod_{\substack{j=1 \\ j \neq i}}^n X_{ji}^{\alpha_{ji}}, \quad i = 1, \dots, n, \quad (1)$$

$$q_i = 1 - \sum_{\substack{j=1 \\ j \neq i}}^n \alpha_{ji} > 0, \quad \alpha_{ji} \geq 0, \quad F_i > 0,$$

where F_i, α_{ji} = given numbers,

X_{ji} = the amount of products which sector S_i is purchasing from S_j , $j \neq i$,

X_{ii} = the amount of output production of S_i ,

$X_i = X_{ii} - \sum_{\substack{j=1 \\ j \neq i}}^n X_{ij}$ = the net product of S_i .

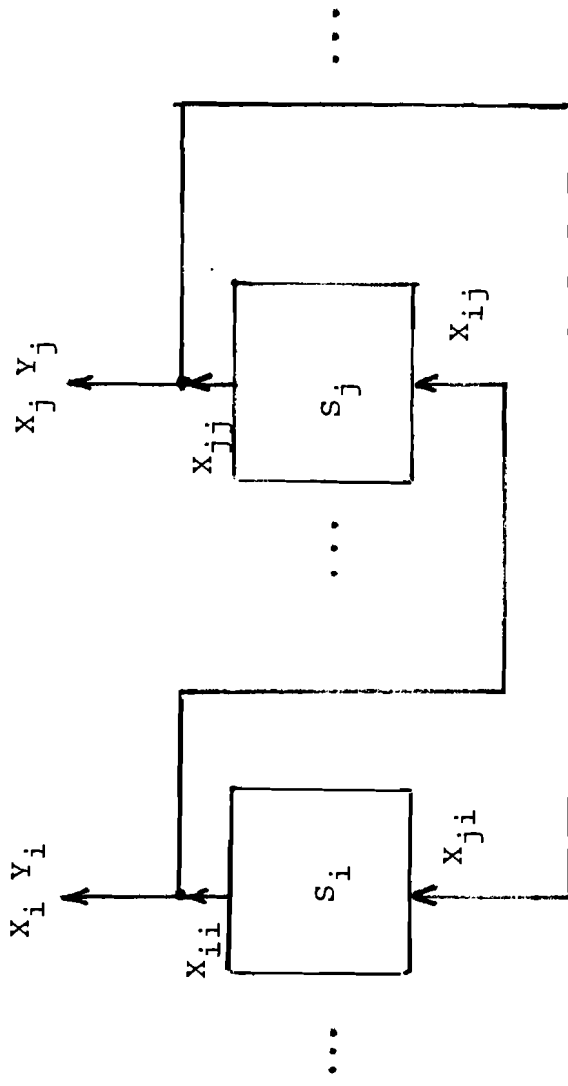

Figure 1

Introducing the sector prices p_i , $i = 1, \dots, n$, it is possible to write the production function (1) in the monetary form:

$$Y_{ii} = K_i \prod_{\substack{j=1 \\ j \neq i}}^n Y_{ij}^{\alpha_{ij}} \quad (2)$$

where

$$Y_{ij} = p_j X_{ij} \quad , \quad K_i = p_i F_i^{q_i} \prod_{\substack{j=1 \\ j \neq i}}^n p_j^{-\alpha_{ji}} \quad , \quad i, j = 1, \dots, n \quad .$$

It is assumed that each sector maximizes the net profit (value added):

$$D_i = Y_{ii} - \sum_{\substack{j=1 \\ j \neq i}}^n Y_{ji} \quad , \quad i = 1, \dots, n \quad , \quad (3)$$

by choosing the best mix of inputs $Y_{ji} = \hat{Y}_{ji}$, $i, j = 1, \dots, n$, $j \neq i$.

As shown in [16, 17], there exists a unique strategy \hat{Y}_{ji} , $i, j = 1, \dots, n$, $j \neq i$, for each sector which maximizes (3). That strategy can be derived by formulae:

$$\hat{Y}_{ji} = \alpha_{ji} \hat{Y}_{ii} \quad , \quad j, i = 1, \dots, n \quad , \quad j \neq i \quad (4)$$

$$Y_{ii} = F_i \prod_{\substack{j=1 \\ j \neq i}}^n \left(\frac{\alpha_{ji}}{p_j} \right)^{\alpha_{ji}/q_i} p_i^{1/q_i} \quad , \quad i = 1, \dots, n \quad . \quad (5)$$

Using that strategy, one gets:

$$D_i = \hat{D}_i = (1 - q_i) \hat{Y}_{ii} \quad , \quad i = 1, \dots, n \quad , \quad (6)$$

and the gross product becomes

$$Y = \sum_{i=1}^n p_i X_i = \sum_{i=1}^n Y_i = \sum_{i=1}^n \hat{D}_i \quad . \quad (7)$$

As follows from relations (4, 5) the normative n-sector, non-linear model (1) ÷ (3) behaves, under optimum strategy, in a similar way to the linear (Leontief) model with the technological coefficients α_{ji} , $i, j = 1, \dots, n$, $i \neq j$. However, the outputs $\hat{Y}_{ii} = 1, \dots, n$, are specified in the unique manner by p_j , $j = 1, \dots, n$, and F_i . That property can be used for identification of the production function elasticities α_{ji} , $j, i = 1, \dots, n$, $j \neq i$, and F_i , $i = 1, \dots, n$ by input-output tables of the given economy [16, 17].

Using the relations (5) ÷ (7), it is also possible to observe that the GNP generated by the economy depends in the linear fashion on F_i coefficients. It is assumed that F_i depends in turn on the investments (Z_1), labour (Z_2) and government expenditures (Z_ν , $\nu = 3, \dots, m$) in education, research and development, health services, protection of environment, etc., in, generally speaking, an inertial and nonlinear fashion. Speaking about inertial processes, it is necessary to introduce the time variable (t) explicitly and deal with intensities $y_i(t)$, $i = 1, \dots, n$, $Z_\nu(t)$, $\nu = 1, \dots, m$, $t \in [0, T]$ rather than the integrated within each year values Y_i , $i = 1, \dots, n$, Z_ν , $\nu = 1, \dots, m$.

In the model under consideration, it is assumed that the sector intensities of production $y_i(t)$, $i = 1, \dots, n$ depend on $Z_{\nu i}(t)$, $\nu = 1, \dots, m$, intensities in the following way

$$y_i(t) = \prod_{\nu=1}^m \left\{ f_{\nu i}(t) \right\}^{\beta_\nu} \quad , \quad \sum_{\nu=1}^m \beta_\nu = 1 \quad , \quad (8)$$

where

$$f_{vi}(t) = \int_{-\infty}^t k_{vi}(t - \tau) [z_{vi}(\tau)]^{\alpha_v} d\tau, \quad 0 < \alpha_v < 1, \quad * \quad (9)$$

and

$$\begin{aligned} k_{vi}(t) &= K_{vi} e^{-\delta_{vi}(t - T_{vi})}, & t > T_{vi} \\ &= 0, & t < T_{vi}, \end{aligned} \quad (10)$$

where K_{vi} , δ_{vi} , T_{vi} , α_v = given positive numbers.

The integral relation (9) takes care of inertial phenomena in investment, research and development, etc.; T_{1i} represents the construction delay, δ_{1i} -- the depreciation of capital investments in time. Since the labour effect on production is generally not inertial, it is possible to assume

$$k_{2i}(t) = K_{2i} \delta(t), \quad i = 1, \dots, n$$

where $\delta(t)$ is the unitary Dirac's pulse. The α_v , $v = 1, \dots, n$ take care of nonlinear saturation effects (i.e. an increasing return to scale is not possible).

Using the production functions (8), it is possible to formulate the optimization of development problem, which consists in finding the nonnegative strategies $z_{vi}(t) = \hat{z}_{vi}(t)$, $v = 1, \dots, m$, $i = 1, \dots, n$, $t \in [0, T]$ such that the discounted output:

* The continuous variables are used here instead of discrete (changing once a year), which is a matter of convenience rather than of general methodology.

$$Y = \int_0^T (1 + \varepsilon)^{-t} \sum_{i=1}^n y_i(t) dt, \quad (11)$$

is maximum subject to the limitation of production factors:

$$\sum_{i=1}^n \int_0^T z_{vi}(t) dt \leq z_v, \quad v = 1, \dots, m, \quad (12)$$

where $\sum_{v=1}^m z_v$ should be generally in balance with the gross product generated by the economy within the optimization interval $[0, T]$.

In the production model (8) ÷ (10), it is assumed that a directed technical progress takes place as a result of government expenditures $z_{vi}(t)$. When only a given part $a'_v z_v$ is used for that purpose and the rest $a''_v z_v$ ($a'_v + a''_v = 1$) has a neutral effect (with respect to the sector production) one can write, instead of (9), (12)

$$f_{vi}(t) = \int_{-\infty}^t K_{vi}(t - \tau) [z'_{vi}(\tau)]^{\alpha'_v} [z''_v(\tau)]^{\alpha''_v} d\tau, \quad (9')$$

$$\sum_{i=1}^n \int_0^T z'_{vi}(t) dt \leq a'_v z_v, \quad \alpha'_v + \alpha''_v = \alpha_v, \quad (12')$$

$$v = 1, \dots, m,$$

respectively.

The functions $z_v(\tau)$ in (9') are regarded as given government expenditures (for example the expenditures in basic education, health service, etc.).

As shown in [16, 17, 19], a unique optimization strategy for (11, 12) exists and can be derived effectively, while the value of Y under optimum strategy becomes

$$Y = \hat{Y} = G^q \prod_{v=1}^m Z_v^{\delta_v} , \quad (13)$$

where

$$\delta_v = \alpha_v \beta_v , \quad q = 1 - \sum_{v=1}^m \delta_v ,$$

and G is a number depending on T and $k_{vi}(t)$ parameters, $v = 1, \dots, m$, $i = 1, \dots, n$.

Solving the allocation problem

$$\max G^q \prod_{v=1}^m Z_v^{\delta_v} , \quad (14)$$

subject to

$$\sum_{v=1}^m Z_v \leq Z , \quad Z_v \geq 0 , \quad v = 1, \dots, m . \quad (15)$$

It is also possible to derive the optimum allocation of government expenditures among the different spheres of activity (i.e. \hat{Z}_v , $v = 1, \dots, m$).

It should be observed that the model under consideration is a normative decentralized model of long-term development of a centrally planned economy. The sectors are concerned mainly with the optimization of inputs purchased from the other sectors, while the higher level decision units allocate the resources (i.e. Z_v) in the most effective way.

The models work in such a way that the supplies

$$\hat{Y}_i = \hat{Y}_{ii} - \sum_{\substack{j=1 \\ j \neq i}}^n \hat{Y}_{ij} = \hat{Y}_{ii} - \sum_{\substack{j=1 \\ j \neq i}}^n \alpha_{ij} \hat{Y}_{jj} \quad , \quad i = 1, \dots, n \quad , \quad (16)$$

should be equal to the given demands Y_i , $i = 1, \dots, n$ claimed by the consumption sectors:

$$\hat{Y}_i = \sum_{v=1}^m \lambda_{vi} Z_v \quad , \quad i = 1, \dots, n \quad ,$$

where λ_{vi} = given nonnegative coefficients determining the v -th expenditure contribution to the demand confronting the i -th production sector.

Since Z_v are determined by the solution of optimization problem (14, 15): i.e. $Z_v = \hat{Z}_v$, $v = 1, \dots, m$, where

$$\hat{Z}_v = \gamma_v Z \quad , \quad v = 1, \dots, m \quad ,$$

$$\gamma_v = \frac{\delta_v}{\sum_{v=1}^m \delta_v} \quad ,$$

and Z is determined by the gross product to be spent during the time interval under consideration

$$Y_i = \sum_{v=1}^m \lambda_{vi} \gamma_v Y_0 \stackrel{\text{df.}}{=} \ell_i Z \quad , \quad i = 1, \dots, n \quad . \quad (17)$$

In the case when we are interested in allocation of gross product within one (e.g. the basic year $t = 1$), Z should be regarded as the GNP generated at the end of $t = 0$. When we

are dealing with a long-term planning interval T , the value of Z represents the gross product generated between the end of $t = 0$ and the beginning of $t = T$.

Solving the equations

$$\hat{Y}_{ii} - \sum_{\substack{i=1 \\ i \neq j}}^n \alpha_{ij} \hat{Y}_{jj} = \lambda_i Z, \quad i = 1, \dots, n, \quad (18)$$

where \hat{Y}_{ii} are determined by (5), it is possible to get equations for prices p_i , $i = 1, \dots, n$, necessary to satisfy the equilibrium [16, 19]:

$$\ln p_i - \sum_{\substack{j=1 \\ j \neq i}}^n \alpha_{ji} \ln p_j = q_i \left[\ln \frac{\lambda_i Z}{a_i F_i} + \sum_{v=1}^m \delta_v \ln \omega_v \right], \quad (19)$$

$i = 1, \dots, n,$

where

$$\alpha_i = \prod_{\substack{i=1 \\ j \neq i}}^n \alpha_{ji}^{\alpha_{ji}} / q_i,$$

ω_v - are prices of production factors and in particular,
 ω_1 - price of capital,
 ω_2 - average salary.

In the case of the open economy, it is necessary also to take into account the additional trade sectors. The domestic production functions (2) should be then supplemented by the factor $Y_{01}^{\alpha_{01}}$, while q_i becomes $\bar{q}_i = q_i - \alpha_{0i} > 0$, $i = 1, \dots, n$. In (19) we should add the term $\alpha_{0i} \ln p_0^i$, where the price for the foreign trade can be written as

$$P_{0i} = P_{i0} / T_{0i},$$

\bar{p}_{0i} = the price of imported commodity (in foreign currency),
 $T_{0i} = p_{i0}/\bar{p}_{0i}$ = terms of trade (export to import price ratio).

A more convenient form of the price equation (19) for $T = 1$ one gets introducing the sector price indices

$$p_i^t \stackrel{\text{df}}{=} \frac{p_i(t)}{p_i(t-1)}, \quad i = 1, \dots, n, \text{ and the ratios:}$$

$$z^{t-1} \stackrel{\text{df}}{=} \frac{z(t-1)}{z(t-2)}, \quad \ell_i^t \stackrel{\text{df}}{=} \frac{\ell_i(t)}{\ell_i(t-1)}, \quad F_i^t \stackrel{\text{df}}{=} \frac{F_i(t)}{F_i(t-1)},$$

$$\omega_v^t \stackrel{\text{df}}{=} \frac{\omega_v(t)}{\omega_v(t-1)}, \quad T_{0i}^t \stackrel{\text{df}}{=} \frac{T_{0i}(t)}{T_{0i}(t-1)},$$

$$i = 1, \dots, n, \quad v = 1, \dots, m :$$

$$(1 - \alpha_{0i}) \ln p_i^t - \sum_{\substack{j=1 \\ j \neq i}}^n \alpha_{ji} \ln p_j^t = \alpha_i \left[\ln \frac{\ell_i^t z^{t-1}}{F_i^t} + \sum_{v=1}^m \delta_v \ln \omega_v^t \right] - \alpha_{0i} \ln T_{0i}^t, \quad i = 1, \dots, n. \quad (20)$$

All the variables on the right side of (20) are exogenous. Analyzing equation (20), it is possible to see how the change of gross product (z^{t-1}), factor prices (ω_v^t), terms of trade (T_{0i}^t), change of consumption structure (ℓ_i^t) and investments (F_i^t) influence the domestic market prices (p_i^t).

Using the price model (20), it is possible to derive the value of gross product in constant, base year, prices (\bar{y}). For that purpose, it is necessary to multiply the current values $y_i(t)$ by the price indices $\prod_{\tau=1}^t p_i^\tau$.

Then

$$\bar{y}(t) = \sum_{i=1}^n y_i(t) \prod_{\tau=1}^t p_i^{\tau}, \quad t = 1, 2, \dots$$

Consequently (11) can be expressed as

$$\bar{y} = \sum_{t=0}^T (1 + \epsilon)^{-t} \sum_{i=1}^n y_i(t) \prod_{\tau=1}^t p_t^{\tau}. \quad (21)$$

The value of \bar{y} can be regarded as a measure of national benefits resulting from the optimum development strategy. It can be written as well in the form (13):

$$\bar{y} = G^q \prod_{v=1}^m \bar{z}_v^{\delta_v}, \quad (22)$$

which shows how the allocation of resources contributes to the gross product.

III. Optimization of Regional Development

As shown in [16, 17], the methodology described can be used effectively for modelling of long-term national development. In the present paper, we would like to investigate how that methodology could be used for modelling of regional development and regional planning.

First of all, it can be observed that the national model can be decomposed into regional submodels if all the statistical data are available. One can consider also a particular regional model S_r cooperating with the rest of the country S_c (Figure 2). All the submodels' technological (and other) coefficients should be estimated or chosen in such a way that the aggregated submodels give the same set of basic

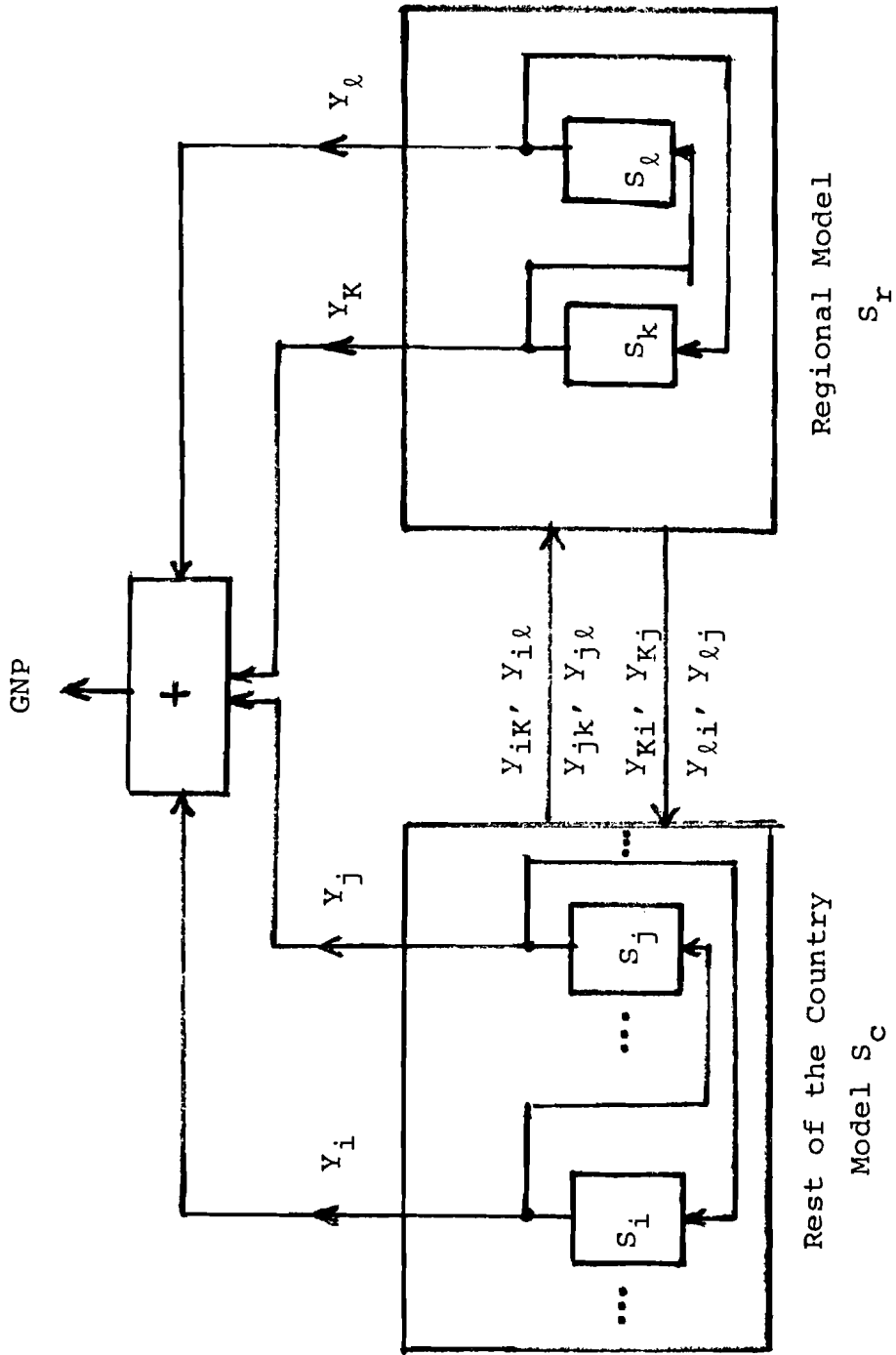

Figure 2

relations as the core national model. Then the sector's strategies, regarding the allocation of production factors among the set of regions, can be analyzed. If we consider, e.g. a particular production sector S_i and N regional production functions of the general type (8), the contribution of j -th region to the regional production $y_{ij}(t)$ can be written as

$$y_{ij}(t) = \prod_{v=1}^m \left\{ f_{vij}(t) \right\}^{\beta_v} \quad (23)$$

where

$$f_{vij}(t) = \int_{-\infty}^t k_{vij}(t - \tau) [z_{vij}(\tau)]^{\alpha_v} dt ,$$

$$k_{vij}(t) = \begin{cases} K_{vij} e^{-\delta_{vi}(t-T_{vi})} , & t > T_{vi} \\ 0 & , \quad t < T_{vi} . \end{cases}$$

We shall assume also that the total regional resources Z_{vj} , $v = 1, \dots, m$, $j = 1, \dots, N$ be given. Then it is possible to find the regional optimum development strategy

$z_{vij}(t) = \hat{z}_{vij}(t)$, $v = 1, \dots, m$, $i = 1, \dots, n$, $j = 1, \dots, N$,
 $t \in [0, T]$, such that

$$Y_j = \int_0^T (1 + \varepsilon)^{-t} \sum_{i=1}^n y_j(t) dt \quad (24)$$

is maximum subject to

$$\sum_{i=1}^n \int_0^T z_{vij}(t) dt \leq z_{vj} \quad , \quad v = 1, \dots, m$$

$$, \quad j = 1, \dots, N \quad (25)$$

$$z_{vij}(t) \geq 0 \quad , \quad i = 1, \dots, n \quad , \quad t \in [0, T] \quad .$$

The optimum strategies can be used to derive the value of $Y_j = \hat{Y}_j$, which takes the form (13)

$$\hat{Y}_j = G_j^q \prod_{v=1}^m z_{vj}^{\delta_v} \quad , \quad j = 1, \dots, N \quad . \quad (26)$$

The problem which presently faces us is to derive the optimum values of $z_{vj} = \hat{z}_{vj}$, $v = 1, \dots, m$, $j = 1, \dots, N$, which would maximize

$$Y = \sum_{j=1}^N G_j^q \prod_{v=1}^m z_{vj}^{\delta_v} \quad , \quad (27)$$

subject to

$$\sum_{j=1}^N z_{vj} \leq z_v \quad , \quad v = 1, \dots, m \quad , \quad (28)$$

$$z_{vj} \geq 0 \quad , \quad v = 1, \dots, m \quad , \quad j = 1, \dots, N \quad . \quad (29)$$

It can be easily verified that a unique optimum strategy exists and it can be derived by the formulae:

$$\hat{z}_{vj} = \frac{G_j}{G} z_v \quad , \quad j = 1, \dots, N \quad ,$$

$$v = 1, \dots, m \quad , \quad (30)$$

where $G = \sum_{j=1}^N G_j$.

Using the present method, we can derive the optimum allocation of production factors and government expenditures among different regions and production sectors within the planning interval. There is, however, an obvious drawback to the present approach: it is very much production oriented, i.e. it takes into consideration, first of all, the efficient allocation of resources. The government expenditures in education, health services are treated here as complementary (i.e. supporting) production factors. A possible way to avoid that drawback is to assume that a part of the government budget is used for an increased financing of these regions which are behind the average country's figures. In that case, we can use the production function (9') where $z_{jv}(\tau)$ represent that part of government expenditures which has a neutral (with respect to a particular technology) production effect. In order to allocate that part of government expenditure, in an explicit form, a method described in [18] can be applied. According to that method, a regional dissatisfaction function can be constructed of the general form:

$$D_j(Z) = d_j \prod_v |\bar{z}_{jv} - z_{jv}''|^{\beta_v}, \quad j = 1, \dots, N$$

where d_j, β_v - given positive numbers,
 \bar{z}_{jv} - given country's average (per capita) of government expenditure level.

The problem consists in finding $z_{jv} = \hat{z}_{jv}''$, $j = 1, \dots, N$,
 $v = 1, \dots, m$, such that

$$D = \sum_j D_j$$

is minimum subject to

$$\sum_j z_{jv}'' \leq a_v'' z_v \quad , \quad v = 1, \dots, m \quad ,$$

$$z_{jv}'' \geq 0 \quad , \quad j = 1, \dots, N \quad .$$

The numerical value of a_v' , a_v'' , $v = 1, \dots, m$, can be estimated from past (historical) data, or considered as decision variables.

Using that approach, the regional benefit (utility) function (26) can be written as

$$Y_j = G_j^q \prod_{v=1}^m (z_{vj}')^{\delta_v'} (z_{vj}'')^{\delta_v''} \quad , \quad \delta_v' + \delta_v'' = \delta_v \quad , \quad (31)$$

$$j = 1, \dots, N \quad ,$$

which shows the contribution of all government expenditures to the regional welfare. That contribution can be regarded in two possible ways. The direct way in the form of salaries (Z_{1j}'), education, medical and social care organized by production sectors (Z_{vj}') and the indirect way (expressed by Z_{vj}'') in the form of public education, social and medical care, environment protection organized by regional and government institutions. The main factor, determining the regional growth in terms of Y_j is, of course, G_j , which depends on the K_{vij} , $i = 1, \dots, n$, $v = 1, \dots, m$ factors. Since the numerical values of K_{vij} in the model under consideration are being determined ex post from statistical data, the model has a tendency to maintain the existing development trends. However, it is a rather common situation that regional growth depends as well on new geological discoveries, for example, which change the existing regional production structure.

For that reason a more detailed location analysis and optimization is needed. In particular, it is necessary to analyze the change of model technological coefficients, resulting from the change of location of production sectors.

IV. Optimization of Regional Location of Production

Consider a simple model, shown in Figure 3, where the national core model cooperates with a new production sector S_r being planned at the given region r . It is assumed that the core model projections of the total investment intensity ($Z_1(t)$), labour cost ($Z_2(t)$) and other government expenditures ($Z_v(t)$, $v = 3, \dots, m$) in the planning interval $[0, T]$ are given. The expenditure intensities connected with the regional project $C_i(t)$, $i = 1, \dots, m$ are assumed to be known. It is assumed that the central planning unit considers a number (M) of different regional projects characterized by given cost functions $C_i^j(t)$, $i = 1, \dots, m$, $j = 1, \dots, M$, where generally

$$C_i^j(t) \leq Z_i(t) \quad , \quad i = 1, \dots, m \quad , \quad j = 1, \dots, M \quad , \\ t \in [0, T] \quad ,$$

but

$$\sum_{j=1}^M C_i^j(t) > Z_i(t) \quad ,$$

at least for some $i \in [1, \dots, m]$, $t \in [0, T]$. Then it is necessary to choose a subset $M' \in M$ of these projects which are most effective for national and regional development. Generally speaking, the projects can be realized at N different regions yielding different values of expected GNP increases:

$$\Delta Y_j = Y_0 - Y_j \quad , \quad j \in N \quad ,$$

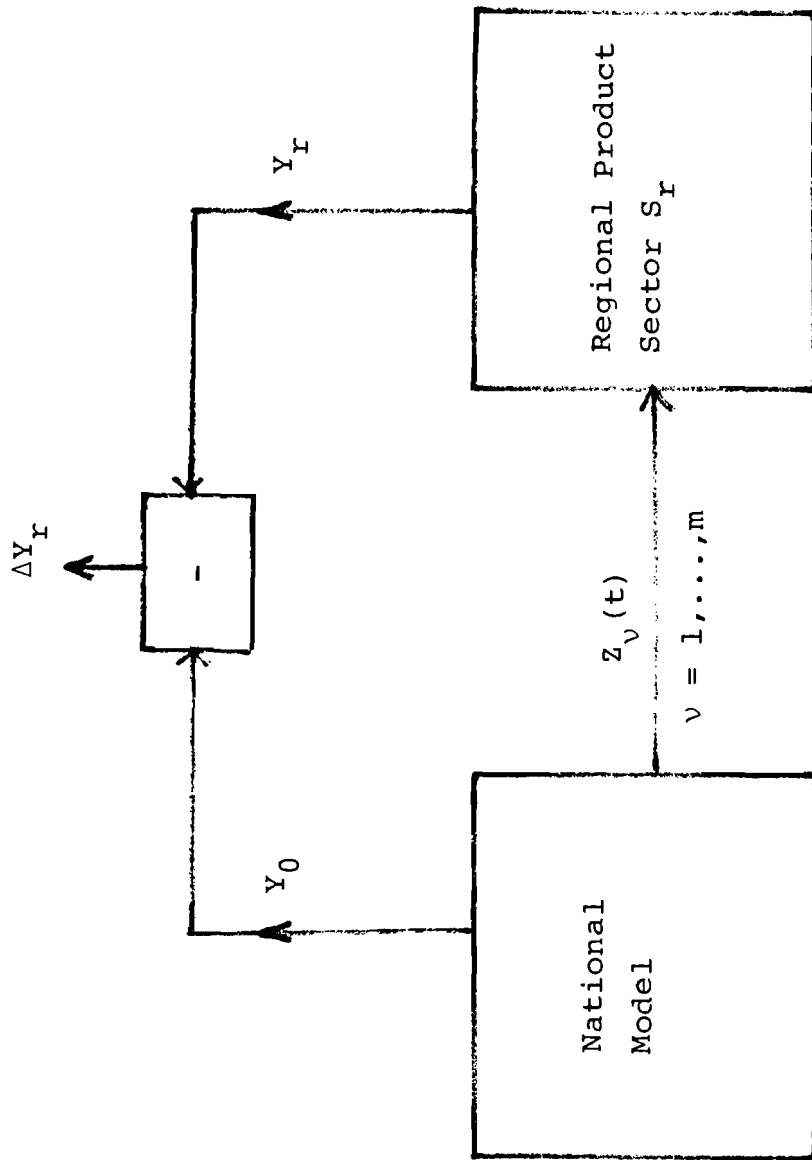

Figure 3

where Y_0 = the GNP generated within the planning interval $[0, T]$ by the core model when all the resources are allocated in optimal manner, but no specific regional project is indicated,

Y_j = the GNP generated within the planning interval, by the core model and regional project, when the cost of regional project resources is shifted from core to regional project.

Since, generally speaking, the change of project location will induce the corresponding change of transport costs and prices for S_r output and other sectors' outputs, it is necessary to derive ΔY_j , $j = 1, \dots, N$, in constant prices. In that way, one takes into account the direct economic effects of regional location as well as the indirect effects resulting from price changes within the whole socio-economic systems. Some of these changes can be regarded as beneficiary (for example, an increase of regional production may decrease the product price and increase the consumption), while at the same time the industrial growth may induce more pollution, decrease the agriculture productivity, etc. Another reason is that dealing with output expressed in constant prices, it is possible to neglect the inflationary effects on the economic growth.

Suppose that at the first stage of regional planning each project has been checked for an optimum location. To do that, it is necessary to find $j = r$, such that $\Delta Y_r = \max\{\Delta Y_j\}$ $j \in N$. When the project inputs and outputs are traded with the core mainly (at least during the planning interval) that process gives us the optimum location of individual projects among the possible regions.

The next step is to choose the best portfolio of projects satisfying the constraints on the available resources generated by the core model. In order to solve that problem, one can use the well known integer programming method. In order to do

that introduce the discrete variables $X_j \in [0,1]$, $j = 1, \dots, M$. The problem consists in finding the strategy $X_j = \hat{X}_j$, $j = 1, \dots, M$, such that

$$\Delta Y = \sum_{j=1}^M X_j \Delta Y_j \quad , \quad (32)$$

attains maximum subject to the constraints

$$\sum_{j=1}^M C_i^j(t) X_j \leq Z_i(t) \quad , \quad i = 1, \dots, m \quad , \quad t = 0, \dots, T \quad . \quad (33)$$

The present method can easily be extended to the case when the regional project involves a complex of n' sectors S_{ri} , $i = 1, \dots, n' \leq n$, which exchange the products with core as well as among themselves. A typical example is an energy complex which involves the coal mine, electric power station, which consumes coal and generates electricity, utilized together with coal to produce chemicals, etc. In the last case, it is necessary to coordinate the core expenditures assigned to different production sectors.

In order to use the proposed methodology for optimization of regional allocation of resources, it is necessary to introduce the regional aspects in the regional (S_r) production function. The main factor which should be taken into account is the change of technological coefficients and prices resulting from the transport cost changes. Consider as an example the core sector production function (2) which corresponds to a fixed location. As follows from (4), for the optimum sector production strategy one gets

$$\alpha_{ji} = \frac{\hat{Y}_{ji}}{\hat{Y}_{ii}} = \frac{p_j \hat{X}_{ji}}{p_i \hat{X}_{ii}} \quad , \quad j, i = 1, \dots, n \quad , \quad j \neq i \quad . \quad (34)$$

Suppose that the project under consideration has been located at the same place as the core production sector and the same technology (requiring the given ratios of $\hat{X}_{ji}/\hat{X}_{ii}$, $j, i = 1, \dots, n$, $j \neq i$) has been adopted. In that case, the project technological coefficients are determined by (34). Suppose now that the location of the project S_r has been changed (with respect to core sector location) and the cost \hat{Y}_{jr} of the inputs \hat{X}_{jr} has changed to become

$$\tilde{Y}_{jr} = \hat{Y}_{jr} (1 + t_{jr}) \quad (35)$$

where t_{jr} - an increasing function of distance between the old and new location. The effect on the economy is the same as if the α_{jr} of S_r had changed to become:

$$\tilde{\alpha}_{jr} = \alpha_{jr} (1 + t_{jr}) \quad . \quad (36)$$

Besides the transport costs which depend on S_r location a new production project may also use more advanced technology, which changes $\hat{X}_{jr}/\hat{X}_{rr}$, $j = 1, \dots, n$. That process is, however,

neutral with respect to location of the project. In a similar way the change of S_r location affects the α_{ri} and \ln coefficients in equations (17) ÷ (20). The final result of these changes is a change of price indices p_i^t , $i = 1, \dots, n$ and the corresponding change of ΔY_j (in constant prices).

In order to derive the effect of $\tilde{\alpha}_{jr}$, $\tilde{\alpha}_{ri}$ on the resulting national model output, one can also consider S_r as an

independent sector with the given $\tilde{\alpha}_{jr}$, $i = 1, \dots, n$ technological coefficient and the price index p_r^t , which can be derived from the extended set of equations (20):

$$\begin{aligned}
 (1 - \alpha_{0i}) \ln p_i^t - \sum_{\substack{j=1 \\ j \neq i}}^n \alpha_{ji} \ln p_j^t - \tilde{\alpha}_{ri} \ln p_r^t &= q_i \left[\ln \frac{\ell_i^t Z^{t-1}}{F_i^t} + \right. \\
 &\left. + \sum_{v=1}^m \delta_v \ln \omega_v^t \right] - \alpha_{0i} \ln T_{0i}^t, \quad i = 1, \dots, n \\
 (1 - \alpha_{0r}) \ln p_r^t - \sum_{j=1}^n \tilde{\alpha}_{jr} \ln p_j^t &= q_r \left[\ln \frac{\ell_r^t Z^{t-1}}{F_r^t} + \sum_{v=1}^m \delta_v \ln \omega_v^t \right] \\
 &- \tilde{\alpha}_{0r} \ln T_{0r}^t.
 \end{aligned} \tag{37}$$

The next step is an aggregation of sector S_r with the corresponding sector in the core model. As shown in [19], such an aggregation results in a new set of aggregated technological coefficients and a new sector price index. It can be observed that a regional location process has an important effect on the technological change and development on the regional, as well as national level.

V. Modelling Spatial Allocation Patterns

It was demonstrated in the previous section how a spatially aggregate regional economic model can be derived from a national model and how regional models can interact with the core model. We shall now turn our attention to the following questions:

1) What are the major inputs to the regional models other than those supplied by the national model or by the

examination of past regional development patterns; and

2) What outputs of the aggregate regional model can be used as exogenous variables in spatial allocation models on an intra-regional scale, and what feedbacks can be established within the spatial allocation models between the exogenous and the endogenous sectors.

In Figure 4, some major linkages are shown between a set of models operating at three spatial levels, i.e. the national, regional, and intra-regional scale. So far the discussion has been focussed on the cells in the upper left and upper central part of the diagram. Now, the linkages in Figure 4 are centered on the spatial interaction model cell and the intra-regional scale is exposed in a greater detail than either of the two remaining scales.

Probably the most important element that has been missing from the spatially aggregate regional model is the demographic-migration component. The model assumes that the total regional resources Z_{vj} , including labour force, are given. Estimates pertaining to labour force may be more readily available when the location of an individual plant is considered; however, they tend to be much more conditional at the inter-regional planning level. In this case, feedbacks between the investment allocation and population change depend on a number of factors. It may be assumed that at $t = 0$ the overall size of labour resources in region j ($j = 1, 2, \dots, n$) are known and these values can be projected to $t = 1$. Supposedly, an investment allocation in region j is based on unique location factors, such as the availability of rich mineral resources, and an import of labour force, especially of particular skills, has to be involved. Now, the model to be employed has to account for the anticipated rather than existing spatial attractiveness patterns. Such models take the general form (see MacKinnon and Skarke, 1975):

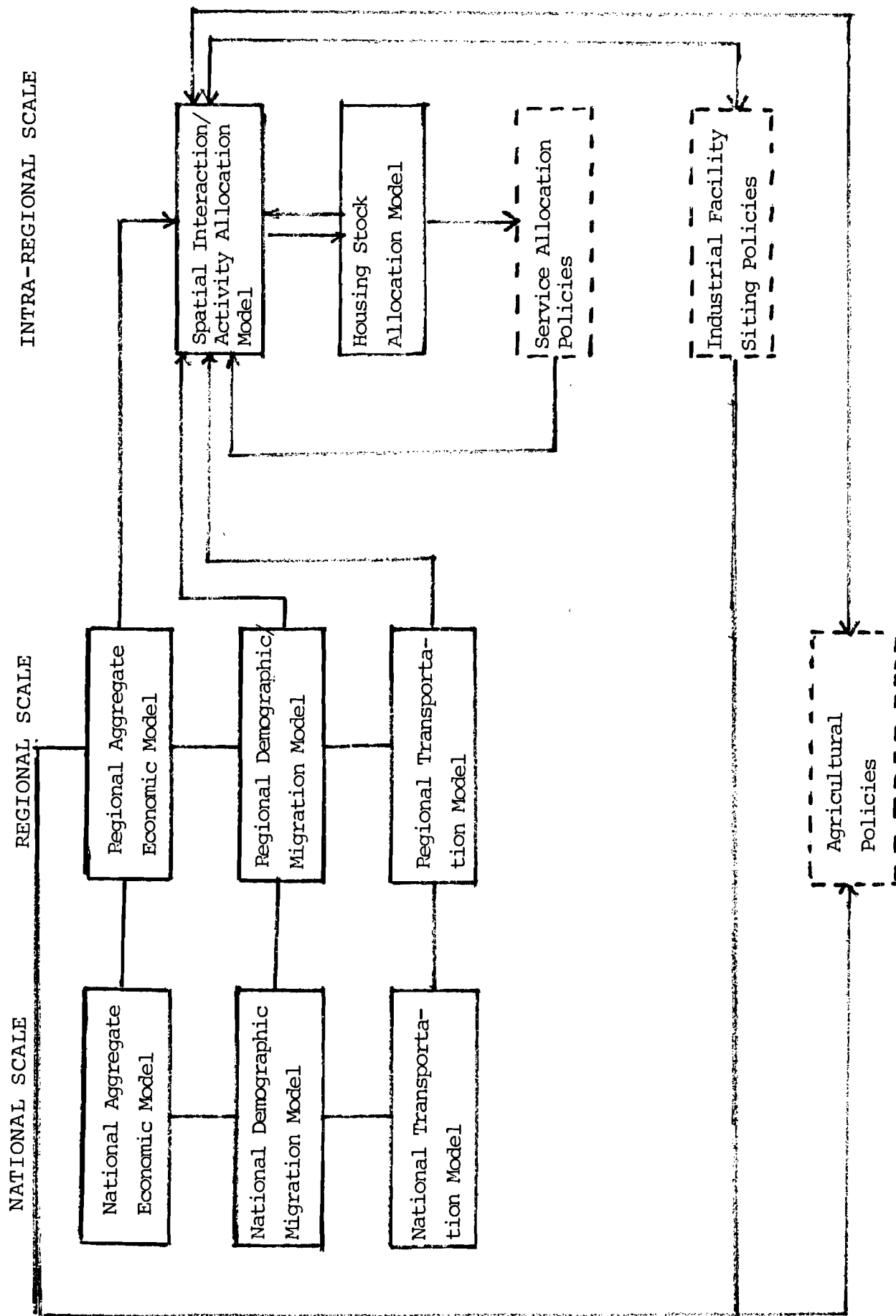

Figure 4

$$T_{ij} = gU_i A_j d_{ij}^{\beta} \quad (38)$$

where T_{ij} is the migration flow between region i and j . U_i stands for uprooting factors at i ; A_j measures attractiveness at j ; d_{ij} = distance impedance function.

There are several problems involved in the practical use of the model. First, U_i and A_j can hardly be estimated from historical data, as they are expected to change rapidly between t_0 and t_1 . One solution, however unsatisfactory, is to estimate these values by analyzing past migration patterns for other regions undergoing rapid industrialization. Second, the predicted magnitude of migrations influences the U_i and A_j values in the following time periods, but, as it was suggested by M. Cordey-Hayes (1974), they increase the probability of both in- and outmigration for regions with A growing over time.

It is assumed that the interaction model of the form (38) supplements the interregional population projections made on the basis of the analysis of age, sex, and natural increase structure. However, A. Rogers (1971) has demonstrated the weight of demographic determinants of migration patterns. His basic model can be represented by:

$$X(t_1) = X(t_0) (B - D + T) \quad (39)$$

where $X(t_1)$ is the predicted interregional population distribution vector, B and D are birth and death matrices, respectively, while T is a matrix composed of T_{ij} elements. The expression $(B - D + T)$ can be enlarged to include a disaggregation of population by age and sex cohorts. This allows to model fertility and mortality rates and also the changes of regional age and sex structure of population resulting from the given ageing and survival ratios and from the migration patterns (Rogers, 1975). Such predictions do not emphasize the cause

and effect chains, i.e. factors that determine particular migration flows between individual regions, nevertheless, they supply critical information to labour force balance sheets for both the in-migration and out-migration regions. Since those predictions are usually based on the analysis of relatively long time series of data, they are able to account for consistent directional biases in migration patterns. Such biases are more difficult to interpret using the interaction model framework.

In the case of regions with consistent out-migration patterns the projections showing probable future age and sex composition of population are of particular relevance for interregional resource allocation planning. Such projections are of direct interest from the point of view of national settlement and population policies (see Dziewonski, 1975). In fact, the framework can be still further extended to account for interregional variations in the degree of urbanization; in this way the predicted changes in demographic characteristics would be adjusted according to the anticipated urbanization level and this would, of course, influence the predicted size and structure of population on an interregional scale. A disaggregation of population by skills and education level can also be contemplated.

Migration flows represent one element in the process of population adjustment to changing spatial attractiveness patterns which are here represented by changing allocation of capital, job opportunities and related governmental expenditures. Another element of this adjustment process is the changing range and intensity of commuting. This subject will be dealt with in greater detail in the last section of the paper. Here it is proper to note the following:

- 1) On an intra-regional scale the migration and commuting models have to overlap since it has been found that long-distance commuting may constitute a first stage of the commuting-migration sequence.

2) On an interregional scale the areal units used in the migration studies should be delimited so as to minimize the amount of cross-boundary commuting. In other words, the spatial units should be equivalent to labour market areas or, even more generally, to functional urban regions.

VI. Spatial Interaction Modelling on an Intra-Regional Scale

Spatial interaction models pertain to locational interrelations between the patterns of major daily population activities such as residence, work, service, and recreation. It is assumed that some of these patterns are determined exogenously, while others are generated by the model mainly as a function of their spatial accessibility to the exogenously located activities. Generally, the size and distribution of employment in the basic sector are given, while the residential distribution and the pattern of service-sector employment are established endogenously.

Spatial interaction models have been applied in the study of individual cities, as well as of larger regions. However, for a model to yield useful results, certain requirements concerning the size and nature of the region and of its constituent zones have to be met. Generally, the region should be defined so as to constitute a relatively closed system in terms of work-trip and service-trip distribution. Apparently, the so-called daily-urban systems, or functional urban regions comply with such requirements. On the other hand, individual zones should be small enough to allow a majority of trips to cross zonal boundaries. If there is little overlap between the labour and customer sheds of individual employment and service nucleations, an intermediate level of spatial units has to be introduced with boundaries corresponding to those of individual commuting sheds.

Let us start with an interaction model of the Lowry type whose general structure can be presented in two functional relationships (Batty, 1971). In a region consisting of n zones:

$$P_j = f(E_i^B, S_i, W_j, c_{ij}, Z_j) \quad (40)$$

$$S_i = f(P_j, F_i, c_{ij}, Z_i) \quad (41)$$

where P_j = population in zone j ;
 S_i = non-basic sector employment in zone i ;
 E_i^B = basic-sector employment in zone i ;
 W_j = measure of residential attraction in zone j ;
 c_{ij} = generalized cost of travel i ;
 Z_j, Z_i = maximum and minimum size constraints on the location of P_j and S_i , respectively;
 F_i = measure of non-basic sector attraction at i .

It can be seen that the following inputs are required by the model:

1) Basic sector employment by zone and area occupied by zone. Basic employment can be defined in terms of: (a) economic sectors (in this case, it covers primary and secondary sectors), (b) economic base theory (here it is equivalent to the export sector), (c) locational characteristics (in this case, it corresponds to those activities whose main locational requirements are not determined by the spatial patterns of other activities within the region), or (d) a combination of a, b, and c.

2) Activity rates, i.e. the ratio of the total population to the total employment (or, to the total labour force).

3) Basic/service employment ratios, or population/service ratios. These follow from 1) and from the control totals of population, as well as from the given activity rates (item 2).

4) Interzonal travel time matrices. These are often defined in terms of airline distance between zone centroids. More refined measures are based on actual travel time by the predominant mode of transportation: sometimes two or more matrices each for a different mode are introduced.

5) Trip distribution functions. Usually an exponential function: $e^{-\beta C_{ij}}$ is assumed and the β parameter is derived from the existing work and service trip data. When such data are lacking, the function is fitted by trial and error methods.

6) Residential location attraction factor. Two measures most frequently used are: actual population size and the built-up area. This, however, introduces a degree of circularity into the model. For forecast runs, data on land area available for residential use are needed.

7) Service location attraction factor. In this case, the actual floorspace occupied by the non-basic sector or the actual non-basic employment have been used as proxy measures, although less direct attraction measures should be required.

8) Maximum population density constraints and minimum size of service center constraints. These are needed to prevent the model from generating excessive densities in zones with the highest accessibility, and from scattering the non-basic employment throughout the residential zones.

Assume now that an interaction model is to be designed for use in a region that is dominated by a single urban core and is characterized by a rather intense commuting to work focussed on the main city, as well as on several secondary urban centers. At present, the region is still predominantly agricultural in character (although a substantial percentage of farms are operated on a part-time basis) but it faces rapid economic, social and physical transformations as a consequence of major mining and industrial development which is to occur during the planned period $t_0 \rightarrow t_1$. The character and location of new investments will bring about a change of the existing

settlement and commuting patterns. Assume further that the interaction model to be used should form a part of a much broader modelling framework which has been discussed in the present paper and that the role and magnitude of change to occur makes the calibration of the model on the historical data for the region of little relevance. The question to be raised pertains to the input sources for the interaction model and the ways its output variables can be used. It follows that:

1) The regional aggregate economic model as outlined in sections III and IV supplies inter alia the data, for the $t_0 \rightarrow t_1$ interval, on the total investments in the basic sector, the total employment in the basic sector, the incomes earned in the basic sector, as well as the data on investments in some of the non-basic activities, i.e. the governmental expenditures on health, education, and welfare. Additional data required by the interaction model concern the location and land area occupied by the basic sector; these data can be supplied from planning studies on facility siting and from land inventories.

2-3) The basic/service employment ratios can be predicted by the aggregate economic models. Employment in agriculture in the region as a whole has to be handled by a separate sub-model. Population activity rates are to be predicted within the framework of a demographic-migration model. It can be expected that those rates will be subject to a critical change as a consequence of inter-sectoral shifts and of sizable in-migration rates.

4-5) Interzonal travel time has often been handled as a policy variable. It is expected that a transportation sub-model to be developed should supply alternative travel time matrices for at least three dominant modes, including rail, bus, and private automobile transportation. A calibration of the trip distribution function on the present data for the region is out of the question. Two possible approaches to be

adopted are: (a) an application of hypothetical functions incorporating normative elements, (b) an application of empirical trip distribution functions as identified for other regions with basic characteristics similar to those which are expected to occur in the region under study.

6-8) As indicated earlier, the existing pattern of population distribution and built-up areas can not be used as a sole residential location attraction factor. The same applies to service floorspace and employment as a measure of the non-basic sector location attraction. What is needed in addition are data on vacant land suited for residential and service development and weighted according to an amenity factor. Such data can be supplied from land inventories and physical environment evaluation studies. It is conceivable that a separate housing stock allocation submodel can be introduced and its output fed into the interaction model. Such a submodel could take into account a number of factors usually disregarded in spatial interaction models, including detailed land characteristics and a priori made assumptions concerning the proportion between different types of housing. The resulting alternative housing distribution and density patterns would then be submitted to spatial accessibility tests.

A review of input sources indicates certain requirements concerning the structure of an interaction model. These are supplemented by other requirements, related directly to the centrally planned economy perspective:

- 1) Spatial interaction models have been criticized for a lack of feedbacks between their exogenous and endogenous variables. This deficiency can be overcome if a model is used within a more general research and planning framework. It has been mentioned that there exist at present at least three different definitions of the basic and non-basic sectors, namely the economic structural approach, the economic base approach and the spatial locational approach. Although there

is much overlap between the three definitions, each of them points out to certain categories of establishments whose distribution can be generated by an interaction model assuming the given approach, but whose location should be given exogenously when taking another approach. This leads to a postulate of a more detailed sectoral disaggregation of the model. What is generally regarded as a basic sector can be disaggregated according to the concept of primary and secondary locational decisions. The primary category would pertain to those activities whose location can not be adjusted to the location of other activities in spite of the fact that they may be spatially interrelated with these activities. A classical example of such activities are mining operations whose location is usually determined by totally external (i.e. geological) conditions and which, in turn, tend to adjust the existing infrastructure patterns, as well as the distribution of other production and service activities.

Another segment of the basic sector constitute those activities which are interrelated with the former category, but whose allocation within the region should be influenced by the existing infrastructure and residential patterns. Finally, the third category of basic sector activities are those unrelated to the remaining two categories on the regional scale. Alternative locations of such establishments can be generated within an interaction model. So far spatial interaction models have been based upon the assumption that people follow jobs, although an opposite trend has been equally well documented, both empirically and theoretically. A disaggregation of the basic sector requires a prior knowledge of interindustry linkages at the national, as well as regional scale and such knowledge can be supplied from aggregate economic models of the type discussed earlier.

Another kind of feedback to be developed relates to relationships between the labour demand by the basic sector and the labour supply as established by a demographic-

migration model. In this case, an interaction model can participate in setting the population control totals (and, indirectly, the size of basic employment) by determining a likely commuting range for each alternative mix of transportation and housing policies. The greater the commuting range, of course, the larger the population totals to be considered under ceteris paribus assumptions as to competing influence of other employment centers.

2) Interrelated with the feedbacks problem is the question of supply-side oriented interaction models. So far the supply side has been usually represented in an attraction term, as in the single-constrained residential allocation model (Wilson, 1972). This term, however, can be replaced by a housing-supply term:

$$T_{ij} = B_j H_i E_j \exp(-\beta c_{ij}) \quad (42)$$

where T_{ij} = the flow of workers from the employment zone j to the residential zone i ;

E_j = employment in zone j ;

B_j = balancing term;

H_i = residential location attraction factor at i , here represented by the housing supply.

There have been attempts to model floorspace distribution and then allocate people according to the floorspace pattern. It has also been suggested that Hansen's (1959) model can be used in this context as a housing-allocation submodel. However, in both cases the main factor determining the housing pattern is spatial accessibility to basic jobs and, therefore, a circularity rather than feedback results in the model. A viable housing allocation submodel should consider, along with spatial accessibility, such factors as environmental quality (amenities), land characteristics from the costs of construction and maintenance point of view, as well as capital

investment constraints (as supplied by aggregate economic models) which may partly determine the prevailing house types and residential densities. The so-called Warsaw optimization technique is one of housing allocation models available, but further developments are necessary.

On the other hand, the service-sector allocation sub-model can be basically handled within the demand-side framework. This leaves enough room for testing alternative hierarchical arrangements of service centers, as well as for the consideration of time lags occurring between a change in residential distribution and the respective adjustments of the service sector.

3) Spatial interaction models should be more explicitly based upon the concepts of daily and weekly human activity patterns. So far the models have accounted for two major interaction components, i.e. the work- and service trips. Admittedly, the latter category is rather broad and it includes, for example, all educational trips. Nevertheless, at least two important types of spatial interaction, namely, the social contacts and recreational trips, are not really reflected in the models' structure. An interaction model should also explicitly consider some limitations on the conversion of agricultural land, other than a simple population density constraint. This becomes crucial when the development of feedbacks between the basic and non-basic sectors is assumed. When these terms are added, the basic functional relationship can be represented as:

$$P_j = f(E_i^B, S_i, N_i, R_i, W_j, Z_j^P) \quad (43)$$

where N_i = social clustering term, measured as population potential at the regional scale;

R_i = recreational dispersion term, i.e. accessibility to open space;

W_j = the residential attraction term may be equal to H_i ;
the latter term accounting for the environmental
amenity factor;
 E_i^B is subject to an agricultural land conversion
constraint, Z_i^A .

4) One of the problems rather difficult to handle within an interaction model framework is the disaggregation of residential population by income categories and the differentiation of the housing market. Although disaggregated models, such as the Cheshire model, have in fact been used, there has been much dispute as to the merits of the procedure. It has been demonstrated (Korcelli, 1975) that under the centrally planned economy there are no major variations in the locational behavior of different socio-occupational groups. This is due to a number of factors, including a largely non-competitive character of the land development process, as well as an absence of a substitution mechanism between land and transportation inputs on a large scale. This is because of the dominant role played by public transportation (the bulk of the travel cost being borne by the state) and of the operation of rather uniform housing standards. In the long-term planning perspective, the substitution mechanism may grow in importance and there may also be an increasing spatial differentiation based on family structure due to the life-cycle migration patterns. Such developments should be accounted for in the design of the housing supply submodel.

5) There has been also much dispute over the use of spatial interaction models as optimization models. Apparently, they can serve to evaluate particular variables, for example, the total travel cost and to indicate the kind of spatial arrangement conducive to a minimization of such a cost, subject to density and other constraints. Spatial interaction models fail short of being optimization models in a comprehensive

sense, since there have been no acceptable comprehensive optimization concepts developed pertaining to the overall spatial structure of cities and regions. Nevertheless, such models can be applied in a broader research and planning framework along with economic optimization models. Their main function is to expose spatial consequences of planning decisions and to make them subject to a number of tests.

More specifically, the models can be used: (a) to test alternative industry siting, transportation, housing density policies; (b) to identify areas of possible conflicts, for example, between the residential and agricultural sectors, or between basic activity locations and environmental policies, and to indicate ways of resolving such conflicts; (c) to analyze impacts of new major developments on the existing spatial structure; (d) to conduct feasibility tests, for example, with respect to the efficiency of transportation systems.

Comprehensive spatial patterns, as predicted by the models, can be evaluated according to a number of criteria. These include: (a) the investment cost criteria, (b) the interaction criteria, such as mean length of trips, (c) density criteria, i.e. the amount of residential space per family and the proximity to the open space. More detailed lists of evaluation criteria were developed by M. Echenique and others. Such criteria are considered in terms of trade-offs, as between density and accessibility, or between amenity and accessibility.

VII. Conclusions

The aim of this paper has been to prepare a framework for the planning-oriented study of regional development. It has been postulated that regional models can be placed within a broader research and planning spectrum ranging from the national to intra-regional scale. An aggregate regional economic model was derived from the national core model and

its linkages were traced throughout the hierarchy of scales. On the other extreme, assumptions pertaining to the development and application of a spatial interaction model were put forth. In particular, possible linkages to the aggregate economic model and to spatial labour force-migration models were discussed.

References

- [1] Bandman, M. "Optimizatsya prostranstvennoy struktury Khozyaystva ekonomicheskogo rayona." In Primenenye modeley dlya razrabotki skhem formirovaniya TPR. Novosibirsk, 1973.
- [2] Batty, M. "Approaches to Calibrating the Garin Lowry Model." In Papers from the Symposium on an Urban Development Model. CES, CP 2, London, 1971.
- [3] Berry, B.J.L. "Hierarchical Diffusion: The Basis of Developmental Filtering and Spread in a System of Growth Centers." In N.M. Hansen, Ed. Growth Centers in Regional Economic Development. New York, 1972.
- [4] Cordey-Hayes, M. "Migration and the Dynamics of Multi-Regional Population Systems." Environment and Planning, 7 (1975).
- [5] Cumberland, J. Regional Development: Policies and Prospects in the United States. The Hague, 1973.
- [6] Ekonomiko-geograficheskiye problemy formirovaniya territorialno-proizvodstvennykh kompleksov Sibirii. Novosibirsk, 1974.
- [7] Granberg, A.G. Optimizatsya territorialnykh proporsiy narodnogo Khozyaystva. Moskva, 1973.
- [8] Hägerstrand, T. The Propagation of Innovation Waves. Lund, 1952.
- [9] Hansen, W.G. "How Accessibility Shapes Land Use." Journal, American Institute of Planners, 31 (1959).
- [10] Hermansen, T. "Development Poles and Related Theories: A Synoptic Review." In N.M. Hansen, Ed. Growth Centers in Regional Economic Development. New York, 1972.
- [11] Isard, W. Location and Space Economy. Cambridge, Massachusetts, 1956.
- [12] Isard, W., Schooler, E.G. and Vietorisz, T. Industrial Complex Analysis and Regional Development: A Case Study of Refinery-Synthetic Fiber Complexes and Puerto Rico. New York, 1959.

- [13] Korcelli, P. Urban Spatial Interaction Models in a Planned Economy: A Preliminary Appraisal. A paper presented at the Regional Science Association conference, Budapest, 1975.
- [14] Kudinov, O.V. "Strategy of the Spatial Distribution of Productive Forces and Population in the USSR." In H. Swain, Ed. National Settlement Strategies: East and West. IIASA CP-75-3. Laxenburg, Austria, International Institute for Applied Systems Analysis, 1975.
- [15] Kulikowski, R. "Modelling and Optimum Control of Complex Environment Systems." Control and Cybernetics, 2, 1, 2 (1973).
- [16] Kulikowski, R. "Modelling of Production, Utility Structure, Prices and Technological Change." Control and Cybernetics, 4, 4 (1975).
- [17] Kulikowski, R. "Modelling and Optimization of Complex Development." Bulletic Pol. Acad. Sci., 33, 1 (1975).
- [18] Kulikowski, R. "Optimization of Decentralized Regional Supply and Delivery Model." Bulletin Pol. Acad. Sci., 31 [327], 1973.
- [19] Kulikowski, R. "Toward a Global Model: A Methodology for Construction and Linkage of Long-Range Normative Development Models." Control and Cybernetics. Forthcoming, 1976.
- [20] MacKinnon, R. and Skarke, A.M. Exploratory Analyses of the 1966-1971 Austrian Migration Table. IIASA RR-75-31. Laxenburg, Austria, International Institute for Applied Systems Analysis, 1975.
- [21] Paelinck, J. "Programming a Viable Minimal Investment Industrial Complex for a Growth Center." In N.M. Hansen, Ed. Growth Centers in Regional Economic Development. New York, 1972.
- [22] Probst, A.E. Industrial Territorial Complexes in the USSR. A paper prepared for the UNIDO Seminar, Tashkent, 1964.
- [23] Rogers, A. Matrix Methods in Urban and Regional Analysis. San Francisco, 1971.

- [24] Rogers, A. and Willekens, F. Spatial Population Dynamics. IIASA RR-75-24. Laxenburg, Austria, International Institute for Applied Systems Analysis, 1975.
- [25] Thomas, M.D. "Growth Pole Theory: An Examination of Some of Its Basic Concepts." In N.M. Hansen, Ed. Growth Centers in Regional Economic Development. New York, 1972.
- [26] Tiebout, C. The Community Economic Base Studies. New York, 1962.
- [27] Webber, M.M. Impact of Uncertainty on Location. Cambridge, Massachusetts, 1972.
- [28] Wilson, A.G. "A Family of Spatial Interaction Models, and Associated Developments." Regional Studies, 3 (1971).
- [29] Wilson, A.G. Urban and Regional Models in Geography and Planning. London, 1974.