



# **Systems Modeling in Health Care**

**Proceedings of an IIASA Conference  
November 22-24, 1977**

**E. N. Shigan, Editor**

CP-78-12  
DECEMBER 1978



**SYSTEMS MODELING IN HEALTH CARE**

**Proceedings of an IIASA Conference  
November 22-24, 1977**

**E.N. Shigan, Editor**

**CP-78-12  
December 1978**

Views expressed herein are those of the contributors and not necessarily those of the International Institute for Applied Systems Analysis.

**INTERNATIONAL INSTITUTE FOR APPLIED SYSTEMS ANALYSIS  
Laxenburg, Austria**



## PREFACE

An international conference on the elaboration of a dynamic health care systems model was held in Laxenburg on November 22-24, 1977, following conferences held in Baden (1974) and in Moscow (1975). This conference was dedicated to the further development of health care systems modeling at IIASA, its National Member Organizations (NMOs), and international organizations. Participants represented 13 countries and the Headquarters of the World Health Organization and its Regional Office for Europe.

This conference focused on the development and practical application of mathematical models of health care systems elaborated at IIASA and its NMOs. The proceedings include papers submitted by the organizers of this conference, reports by the participants from different national and international organizations, and the main content of discussions that took place during all sessions.



## CONTENTS

Welcoming Address <i>R.E. Levien, Director, IIASA</i>	1
Welcoming Address <i>A. Rogers, Chairman, Human Settlements and Services Area</i>	6
<b>PART I STATE OF THE ART IN THE IIASA HEALTH CARE SYSTEMS MODELING TASK</b>	
The IIASA Health Care Systems Model <i>D.D. Venedictov and E.N. Shigan</i>	11
The Components of the IIASA Health Care Systems Model <i>R.J. Gibbs</i>	20
Aggregate Model for Estimating Health Care System Resource Requirements (AMER) <i>A.A. Klementiev and E.N. Shigan</i>	31
A Disaggregated Health Care Resource Allocation Model <i>R.J. Gibbs</i>	39
Discussion	48
<b>PART II HEALTH CARE SYSTEMS MODELING BY NATIONAL AND INTERNATIONAL CENTERS</b>	
The Role of Validation in Health Care Systems Modeling <i>N.T.J. Bailey</i>	55

Problem-Oriented Global Modeling: Developing a Health Care-Oriented Simulation Model <i>A. Petrovsky, P. Kitsul, W. Olshansky, and A. Yashin</i>	65
Systems Modeling and Health Service Planning in the UK <i>A.G. McDonald</i>	77
Analyzing Demands for Medical Care by Computer Simulation: An Example of Application of a Health Care Systems Model <i>S. Kaihara</i>	100
Toward a Global Equilibrium Model for Health Care Systems Planning <i>J.-M. Rousseau</i>	106
National Aspects of GDR Cooperation with the IIASA Health Care Systems Modeling Task <i>K. Spies</i>	118
The Utility of National Health Care Systems Modeling: One Planner's View <i>J.H. Weiss</i>	121
An Epidemiological Model to Evaluate the Action of a Risk Factor <i>P. Le Beux, P. Goldberg, J. Chaperon, C. Veyssier, M. Goldberg, and F. Gremy</i>	130
Environment and Health <i>Å.E. Andersson and I. Holmberg</i>	138
Discussion	154
 <b>PART III DEVELOPMENT OF NATIONAL HEALTH CARE SYSTEMS MODELING</b>	
Future Directions for the IIASA Health Care Systems Modeling Task <i>E.N. Shigan</i>	161



Socioeconomic Influences in Health and Health Care Modeling <i>P. Fleissner</i>	163
Medical Care Demand Model for Estimating the Cost of Medical Care <i>K. Atsumi, I. Fujimasa, and S. Kaihara</i>	182
The Health Index as a Criterion of Function of a Basic Model of the Human Environment <i>R. Miksl</i>	195
Ambulatory Care in Bavaria <i>W. van Eimeren and W. Koepcke</i>	200
Political Model in the Health Care Sector <i>C. Dietrich</i>	214
Investigation of a Health Care Model at the Town Level <i>Yu.M. Komarov</i>	220
The Systems Approach to Strategic Planning Aspects in the Prevention of Alcohol-Related Problems <i>L. Wasserman</i>	226
Discussion	237
<b>PART IV PLANNER'S REQUIREMENTS FOR MODELS</b>	
Priorities for Health and Personal Social Services in England: The Central Planner's Requirement for Health Care Systems Modeling <i>C. Graham</i>	241
The Planner's Requirements for Health Care Systems Modeling: The Dutch View <i>A. van der Werff</i>	262

Using Models as a Tool for Developing Information Services <i>A.S. Härö</i>	281
Discussion	289
<b>PART V COLLABORATION WITH NATIONAL AND INTERNATIONAL CENTERS</b>	
Aspects of Collaboration between IIASA and WHO in Health Care Systems Modeling <i>N.T.J. Bailey</i>	293
Cooperation with the WHO Regional Office for Europe <i>J.E. Asvall</i>	297
Providing Data for the Management and Planning of Public Health <i>K. Fuchs-Kittowski and P. Gudermuth</i>	300
Mutually Beneficial International Scientific Collaboration in Research Projects <i>Yu.P. Lyachenkov</i>	314
Discussion	320
Modeling Health Care Systems (Report of the Conference) <i>A.S. Härö</i>	323
Concluding Address <i>E.N. Shigan</i>	329
<b>APPENDICES</b>	
Appendix A: List of Participants and Contributing Authors	333
Appendix B: Agenda	337

## WELCOMING ADDRESS

R.E. Levien, Director, IIASA

First, let me say something about the history of IIASA, and then I will tell you about our organization, our research plan, and our style of work.

This is an important time for IIASA. We are now celebrating the fifth anniversary of IIASA's charter, which was signed on October 4, 1972, in London by representatives of 12 National Member Organizations. But this central event in our history was actually preceded by five and a half years of negotiations. The idea for IIASA first arose at the end of 1966, when the then president of the United States, Lyndon Johnson, suggested that an institute be established to work on the common problems of the developed countries and thus to serve as a bridge between East and West. McGeorge Bundy, Johnson's national security adviser, who subsequently became president of the Ford Foundation, was asked to explore this idea with the Soviet Union. In the spring of 1967, Bundy talked with Soviet officials, including Jermen Gvishiani who, then and now, was deputy chairman of the State Committee on Science and Technology in the Soviet Union. It was agreed to proceed with those discussions, which were then followed by five years of multinational negotiations, finally leading to the establishment of the Institute about five years ago.

One of the most important decisions made during the course of those negotiations was that IIASA would not be an intergovernmental organization, but rather would be a nongovernmental organization. Thus the member organizations of IIASA are scientific institutions, not governments. As a result of that decision, the scientists at IIASA come as individuals and not as representatives of their governments, which makes possible an open, free, and objective discussion of issues which, in other forums, might take on a political cast.

A second important decision was acceptance of an offer by the government of Austria to locate the Institute here at Schloss Laxenburg, which had been severely damaged during the war and in the years thereafter. However, as you can see, the Austrian government has completely renovated the Schloss, at a cost of about \$10 million.

The IIASA charter was signed on October 4, 1972, and the first director, Howard Raiffa from the Harvard Business School, assumed leadership. He began with the ambitions of the founders

in mind: to create an institute that would enhance international cooperation, advance science and systems analysis, and apply systems analysis and the findings of science to important international problems. Those who were sceptical about the Institute's chances of survival in those days would have been justified. It was difficult to recruit a staff from 12 different countries and to get them to work together in a new discipline on important international problems. But Raiffa succeeded very well, and by June 1973, the first scientific work at the Institute had already begun. Three years thereafter, we held our IIASA Conference (something we must do every three years according to our charter) to report on progress of the Institute up to that time. The conference was a success and led to further support and additional membership in the Institute.

I have already mentioned that the IIASA charter was signed by 12 National Member Organizations. The list of founding member organizations of IIASA includes: the Royal Society of the UK, the Polish Academy of Sciences, the National Research Council in Italy, the Academy of Sciences of the Soviet Union, the Academy of Sciences of the United States, etc. These organizations agreed to participate during the course of negotiations. In 1973, the Austrian Academy of Sciences became a member; in 1974, the Hungarian Committee for Applied Systems Analysis; and then after the IIASA Conference in 1976, committees from Sweden, Finland, and The Netherlands joined, bringing IIASA's total membership to 17 National Member Organizations.

These organizations have a number of rights and obligations. The first right is to participate in the IIASA Council, which meets annually to set the basic policy for the Institute, and to approve its budget and research plan each year. The principal obligation of the membership is to support the Institute. Each National Member Organization contributes annually to a basic fund for which there are two kinds of contributions. The United States and the Soviet Union are in category A. This year each gave \$1.4 million through their national academies of sciences. Each of the other 15 members contributed \$218,000 this year, giving us a total income of about \$6.12 million. Our founders were very wise in many respects, and they made many good choices. But one unfortunate decision, which was made before the selection of Austria as the site of the Institute, was to denominate our contributions in dollars. At the time the contributions were established the dollar bought 23.2 schillings. But those of you who have been to a bank recently know that you received less than 16 schillings for your dollar, which has, of course, affected the finances of the Institute. Even though dollar contributions have increased, our ability to purchase goods and services in Austria has not increased at all. In fact, it has declined since the initiation of the Institute.

Regarding the research program of the Institute, we have what is called a matrix organization of research with two dimensions, corresponding to the phrases in our title--"international

applied", and "systems analysis". As to the first phrase, one of the first issues for IIASA was to decide what international and applied meant. It certainly meant working on problems of international importance, but there are different kinds of problems, and we found it useful to distinguish two. First, there are "global" problems--issues that inherently cut across national boundaries, that cannot be resolved without the joint action of many countries. For example, preservation of the climate, exploitation of the oceans, planning for our future energy and food supplies. IIASA has a role to play in global problems because we are a unique institution, where scientists from many different countries, spanning a wide range of political, social, and economic space, can work together on the problems we all face in the future.

The second kind of international problems we distinguish are "universal" problems--issues that lie within national boundaries and are subject to the decision power of individual national or regional governments. But these problems are international in the sense that all nations share them. Therefore, IIASA has a role to play in the exchange of experience and information and methodology from country to country, particularly across social, economic, and political boundaries. The problem that you are dealing with at this conference falls in this category. Health care planning is a national problem, a universal problem, which all the nations you represent share. The purpose of your coming together is to exchange your experience and work in this field.

In order to have an impact on major problems, we have established what we call "Programs". These are groupings of people focused on the problems of energy, for example. Two global programs are underway at the moment--the future development of our energy system and a similar problem dealing with food, both on a global scale. Each of these programs has a core staff and then draws the rest of its staff from our "Research Areas". This is the principle that we are trying to develop at the Institute.

The second phrase in our title is "systems analysis", which means different things to different people. Thus a second difficulty that IIASA faced in its early years was to give a meaning to the phrase "systems analysis" in this international setting. After five years of experience, we have concluded that it means, first, a concern with the problems as seen by decisionmakers; but, second, it means taking a holistic view of those problems, that is, an examination not limited by disciplinary or by ministerial or bureaucratic boundaries, but which links those aspects of the problem that really affect decisions. In the real world, these aspects are usually quite diverse. In studying energy, one has to understand the resources that underlie the energy system and the technology, the demands that arise from human needs, and the managerial problems. And one must have the tools to analyze these complex issues. That is true of any real systems analysis, which implies that at IIASA, one must have a wide range of expertise--people who know about resources, about environment, about

human needs--who can join with a small cadre of systems analysts in analyzing a complex problem.

The second dimension of our matrix, "Research Areas", represents four pools of talent. First, Resources and Environment includes the earth's natural endowment--its resources, its environment, and the way they interact. Second, Human Settlements and Services covers the earth's human resources--how they are distributed, the infrastructure needed for their support, the facilities needed to meet their needs. This area is sponsoring this conference, because, of course, health care is one of the needs of the world's human resources. The third Research Area is Management and Technology, which is concerned with manmade contributions to the earth. Our fourth area is System and Decision Sciences, which comprises the mathematical and computational specialists who have the tools and methods needed for dealing with complex systems.

The theory at IIASA is that these pools of people will link us to the state-of-the art and to the communities of experts working in these four important areas, that these scientists will carry on their own research, and that they will also contribute to cross-cutting studies of major important international problems. Each area includes activities that are being undertaken for their contribution to the advancement of the state-of-the-art of that area, and because they may bring to that area some of the benefits of a more general systems analysis approach. The topic of this Conference lies within this part of the Human Settlements and Services Area; it is the study of health care systems modeling, drawing on IIASA's expertise in systems analysis.

To carry out this rather ambitious program, we have relatively restricted internal resources. Our budget of about \$6 million allows us to pay the salaries of about 70 scientists per year, which is a rather small number to carry out the ambitious program I have sketched. In fact, the work we try to do would be impracticable if it had to be carried out by just this staff. IIASA does not aim to be self-sufficient. It is not our purpose to carry out within this Schloss all of the work that is in our program, but to use our core staff as a mobilizing force for bringing together workers and groups from many different nations. And that are representatives in this room of groups from different nations--Japan, GDR, the UK, Finland--who are working together with our team in a collaborative manner. That is the spirit of IIASA; that is the purpose of this Institute.

In addition to the core of about 70 scientists, we have each year about 10 more scientists who are guest scholars--their salaries are paid by their home institutions and they work with us in a variety of capacities. We also receive each year about \$1 million in external funds from UN agencies like UNEP, UNIDO, UNESCO; from foundations--Ford, Rockefeller, and Volkswagen; and from governmental agencies. These funds enable us to hire another 15 scientists. Thus, in fact, the level of effort at IIASA is

not 70, but about 90 to 95 scientist-years each year. But the major augmentation of our forces is through collaborative research--using our internal core to draw together and link research efforts to other institutions with IIASA and with each other, so that the overall impact of collaborative efforts on the major problems can be significant.

Occasionally, we also obtain further benefits from what we call "catalyzed research", that is, work underway in other institutes that is not directly linked to IIASA's research program but is in some way or another inspired by it. And, finally, this Conference is an example of IIASA's information exchange function, one that we hope bears mutual benefit.

Thus it is through the combination of internal effort and mobilized and inspired external effort that IIASA hopes to make some progress against the important problems that our founders and our Council have posed for us. I welcome you to these next few days of deliberations, and I hope that you have a successful meeting. Furthermore, I hope that you will become members of the larger IIASA team and continue your association with the Institute, not only for these few days, but as you return home and keep in touch with us.

## WELCOMING ADDRESS

A. Rogers, Chairman,  
Human Settlements and Services Area

It is a pleasure to welcome you to a conference sponsored by the Human Settlements and Services (HSS) Area.

I would like to introduce you to the broader context of the Human Settlements Area and to how health care activities fit within this broader context. Our Area has several missions, one of the most important being the provision of a core of experts for the various Programs and of joint appointments for tasks that cut across individual Areas. Of course, these experts like to continue some of the research they were doing at their national institutions, so while at IIASA they strive to expand the state of their art in their particular discipline. But, as an interdisciplinary institute we, at the same time, try to coax them into working together across disciplines in order to produce a multidisciplinary, system-analytic view of some of these problems. And, if successful, we disseminate the results. In the process, we often, as Areas, act as seedbeds for future Programs. The Food Program, for example, originated as an activity within the Resources and Environment Area. And, finally, perhaps most importantly, we try to link our work with work going on at national and international institutions.

The HSS Area focuses on people--their needs, their behavior, and their impact on resources and the environment. Research is organized around three major dimensions, which overlap, as most classifications do, but which by and large are distinguishable by the time frame of the decisionmaker addressing these particular issues. At one extreme, we have the short-term management problems faced by decisionmakers, for example, traffic systems control. You may change the signalization system, build another lane, widen the road, but essentially you are dealing with a short-run management problem--you are not changing the structure of the system, just trying to make it work more efficiently.

At the other extreme, there are problems of development, which are long-term, 15- or 20-year horizon problems; long-range plans, for example, fall into this category. And somewhere in between are problems of investment--in human resources, in services--and health care activities fall into this category within our system of organization.

We have just completed next year's research plan and, for the first time, have gone beyond a single annual plan into a



five-year moving plan--moving forward each year. In this plan, we have tried to articulate three major research themes: first, improved methods of systems analysis and its application to urban management problems, what we call urban systems management; second, human resources, viewed as the wealth of nations and the investment in infrastructure and services that they require; and third, human settlement systems, their evolution and their impact on the environment.

Currently, we have ongoing activities in health care, human settlement systems, migration and settlement, and population resources and growth. The latter three deal with, in one way or another, the growth of urban areas, the growth of regions, movements of populations among those regions, and the consequences of such movements. We are currently initiating some new activities and making arrangements for concluding a few old activities. The human settlement systems activity and the migration and settlement activity have been underway since 1975, and we plan to conclude them in 1978. We will hold a capstone conference for each of these tasks and then decide what to do in the future.

Two likely future activities will be combining what we have learned from these two tasks and choosing a schema that draws on the comparative advantages of IIASA, a schema that will probably focus on some of the causes of urban decline and revival. This will complement the ongoing activity on population resources and growth, which is focusing more, for the present at least, on problems of the developing countries, especially those of urbanization, agricultural change, and economic development.

We are also starting a task in nutrition in collaboration with the Food and Agriculture Program, who needs demand inputs for its national system of agricultural models. And we are contemplating starting a new activity in manpower forecasting and manpower planning in the near future. Under the urban systems management theme, we plan to carry out a few state-of-the-art surveys; that is, essentially one- or two man-year operations which are of interest to our various NMOs and which serve the function of information exchange.

In the course of carrying out these research activities, our Area interacts with other IIASA Areas and Programs. For example, we are currently working with the mathematicians in the System and Decision Sciences Area on normative policy models of population growth and development. We are collaborating with the Food and Agriculture Program on the causes and consequences of rural-to-urban migration. We plan to collaborate with the Management and Technology Area on some work in regional health care management in the UK, and also on our work on computer information systems. We are collaborating with scholars in the Resources and Environment Area, providing them with demometric analyses of population's interactions with energy/environment systems. Finally, we plan to collaborate with the Integrated Regional Development work at IIASA by way of providing them with expertise in regional growth and infrastructure demand modeling.

We also interact with institutions outside of IIASA, for example, institutions in our NMO countries, such as the Urban Institute in Washington and the Urban Systems Institute in the Soviet Union. And we have contacts with international organizations, such as the World Health Organization (WHO), the World Bank, the International Labor Organization (ILO), the Population Council, and the United Nations Population Division. Thus it is within this broader picture of research in the Human Settlements Area that the health care activities should be viewed.

PART I

State of the Art in the IIASA  
Health Care Systems Modeling Task



## THE IIASA HEALTH CARE SYSTEMS MODEL

D.D. Venedictov and E.N. Shigan

The development of systems analysis is an important present-day achievement, which has resulted from the need to solve interdisciplinary, complex problems. This methodology pays special attention to the inadequacy of considering only isolated situations. Rather, it is based on a well-known dialectic law concerning the interrelation and interdependence of events, requiring that each event and object be considered not only as a specific system, but also as a subsystem of the larger system.

The health care system (HCS) is considered to be a large and complex dynamic system consisting of a set of interrelated subsystems, very closely related to external systems and joined by the common aim: the health of the population (Figure 1). This system also comprises several hierarchical levels--individual, district, national, regional, and global (Figure 2).

Each level has its own specific and nonspecific problems. *Specific problems* are concerned particularly with the content of information for the components of each level (i.e., patient-doctor, doctor-medical establishment, etc.). One of the most important problems presently facing the health care system is the creation of a computer information system for each hierarchical level. This problem has many aspects, beginning with determining a list of indices for each level of this pyramid and ending with some technical points. These medical information problems are receiving serious attention, not only by national centers but also by international organizations such as WHO, IFIP, and the World Association for Medical Informatics. In 1977 alone, several international congresses ("Medcomp '77" in Berlin, "Medinfo-77" in Toronto, technical discussion during the 27th session of the WHO Regional Committee in Munich, etc.) were held to discuss these problems.

*Nonspecific problems* cover all levels of the system. For example, study of each level as a large dynamic system and study of the relationship of each hierarchical level to external systems are considered nonspecific problems. Solving these problems requires, to a great extent, use of the systems analysis methodology.

These two types of health care problems are interrelated; they overlap. Moreover, problems specific to the individual level (e.g., primary health care) must be considered from the systems analysis point of view. The most important benefit, however, is using systems analysis to answer dynamic, strategic questions.

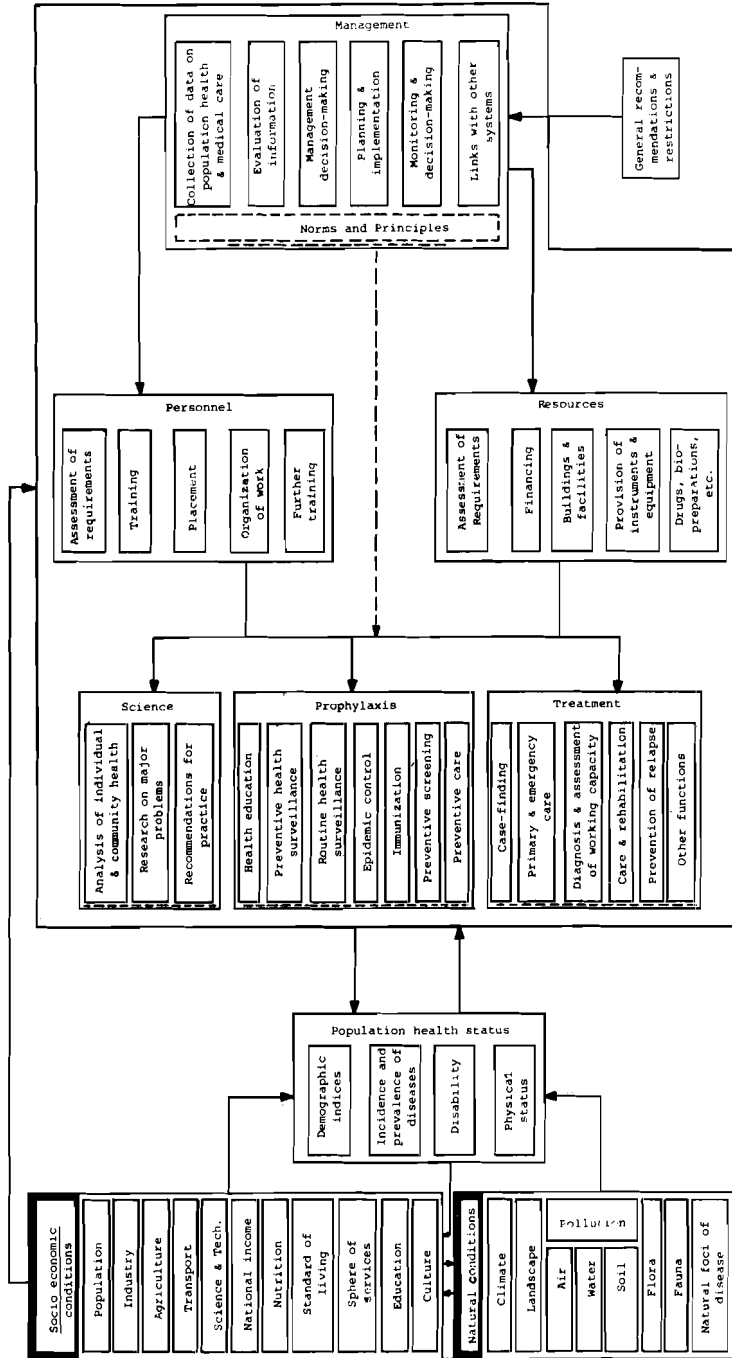

Figure 1. Functional chart of a public health system.

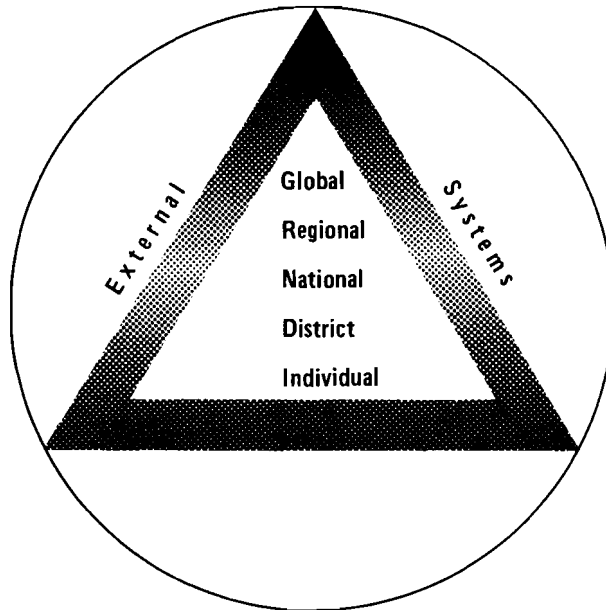

Figure 2. Different levels of the health care system. The goal of the IIASA biomedical group is to elaborate a national health care system (NHCS) model for simulating system activity and testing different policy alternatives.

Although medical expenditures, medical staffs, and numbers of beds are increasing continuously, the persons responsible for HCS development at each hierarchical level are more often facing the problem of answering the questions, "How many and what kinds of medical resources will be needed?" and "How can resources best be allocated in order to provide good health services?" All health managers, from the heads of medical establishments to persons responsible for the national level, are interested in having these questions answered.

Partial answers can be found by conducting experiments with real objects (health centers, hospitals, ambulance services, etc.). But these experiments are expensive and time-consuming, and are unable to test many alternatives for a planning policy.

The situation is much more difficult for health managers at the national level, for to determine medical resource demand and allocation, it is not only necessary to estimate population change, but also to forecast the dynamics of the health of the population. This problem also becomes complicated by the health care system's strong dependence on socioeconomic, environmental, and other external systems. That is why health managers responsible for national health care strategy need a dynamic model of the health care system.

Since 1975, a group of IIASA scientists from different countries has been working on the elaboration of a national HCS model. This model will help the decisionmaker both in simulating the activity of the health care system and in testing different planning alternatives. The meaning and content of this model was described by Venedictov in 1975 as the view of health care as a large dynamic social system [1]. Later this approach was developed by IIASA's HCS modeling group, and there are now several publications describing the model-building process step-by-step. Various IIASA conferences have also been dedicated to HCS modeling.

Although several good examples of the application of optimization models to hospitals, health centers, and other institutions exist, they have not been applied so successfully at the national level. In the health care system, there are many quantitative indices (~300) which reflect the medical, economical, and social aspects of HCS activity. However, the principles of measurement of these indices differ and their "weight" is known. Sometimes they are negatively correlated. Therefore, if we take into consideration the health care system's strong dependence on socioeconomic, environmental, and other systems, it becomes clear that the health care decisionmaker must be involved not only in the model-building process, but also in working with the model in an interactive regime.

IIASA's dynamic simulation model of the national health care system consists of several interrelated submodels. The order in which these submodels were elaborated was: population - health - resource demand - resource supply - resource allocation. In selecting a mathematical method for describing the quantitative problems, we proceeded from the sense of the problems.

#### STEPS, SOME RESULTS, AND THEIR MEANING

To estimate medical resource demand, it is first necessary to build a model for forecasting population changes. Following the recommendation of N. Keyfitz (USA), and in collaboration with A. Rogers and F. Willekens (IIASA), a computer model for forecasting change in population structure was developed, taking into consideration natural and mechanical population movements. By testing this model on real national data, it was shown that it could be used for estimating population trends [2]. An estimation of resource demand also requires knowing the prognosis of the population's health.

From the point of view of medical resource allocation, the most useful health indices are those for morbidity. The population morbidity level is most completely reflected by the prevalence rate. In one publication of the IIASA HCS Modeling Task [3], different alternatives for estimating prevalence rate on the basis of information available in different countries was described.



As to degree of specificity, all morbidity estimation models can be divided into the following types:

- a. *Aggregative morbidity model*, for estimating and forecasting "crude" general morbidity rates without specification as to the group of diseases or specific disease;
- b. *Group morbidity model*, for modeling groups of diseases, i.e., the classes in the International Classification of Diseases (ICD), and groups used in several IIASA publications (degenerative diseases, infections, accidents, etc.);
- c. *Specific morbidity model*, oriented to specific diseases (e.g., cancer, cholera, tuberculosis, etc.);
- d. *State of disease model*, oriented not only to a specific disease, but also to the different stages of the development process or risk-group estimation and classification.

It is much better to use morbidity models specified according to diseases or types of diseases (b, c, d above) for estimating medical resources. But, in this case, information is needed about the frequency of the disease among the population, the number and kinds of laboratory tests, consultations, beds, and physician and specialist time specified for each disease.

Unfortunately, such information is not available in most countries, but it can be obtained by special comprehensive studies. Moreover, each country uses its own classification of hospital departments, laboratory techniques, medical doctor specialties, etc., and the ICD is the only good example of such international agreements. But the estimation of medical resource needs using a specific disease model in one country will be a good example for others. The IIASA HCS modeling group is working on this model on the basis of data from the United Kingdom and Japan. And, besides such specific disease approaches, an aggregative morbidity model is being developed at IIASA.

Analyses of the methods used in morbidity surveys and of the contents of different countries' annual health reports have revealed great diversities. Incomplete registration of illnesses and confidentiality of personal medical information account for difficulties in using these data for estimating health (status and dynamics) and medical resource needs [3]. Thus IIASA's HCS modeling group elaborated mathematical methods for estimating population morbidity based on indirect reliable sources. These methods can be used to forecast not only aggregative data about the morbidity of a population, but also specific morbidity rates for different terminal diseases [4].

On the basis of these methods, a medico-logical suggestion was made about the correlation between complete registered morbidity and mortality patterns in developed countries having similar

disease structures. Comparison of present and past data about the morbidity and mortality of the populations of such countries as Japan, the UK, and the USSR has revealed common trends and a nearly constant relation between mortality and morbidity patterns.

Besides the significance of the developed methods of morbidity estimation to IIASA's national health care modeling, they have some other very important practical applications:

- In countries where there has been difficulty in obtaining and generalizing personal medical information due to the relationship between doctor and patient, these methods can be used to simplify these processes.
- In countries following normative planning or similar approaches, the application of these mathematical methods will bring about a decrease in the number of natural experiments and morbidity surveys.

Having developed models for forecasting population structure and estimating general morbidity data, the IIASA HCS modeling group is currently working on models for medical resource needs and resource allocation.

As to the modeling of resource demands (the supply part of the NHCS), several possible approaches exist (market, normative, etc.). In 1977, the IIASA HCS modeling group applied the normative approach to the NHCS model, which assumes the use of different rates, ratios, means, indices, and structures for calculating medical resource demand.

In the USSR, a scientific approach to normative supply has been developed and is currently in use. Special surveys, conducted by teams of doctors, are used to estimate each disease, in-patient and out-patient visits, hospitalization cases, etc. As a result, the data on each disease taken from these surveys are summarized according to class of disease (following the ICD), medical specialty, establishment, regions in a country, etc. Periodically, these temporal standards, founded through the processes of discovery, treatment, and rehabilitation of the disease, are revised according to the latest achievements in medical science. If we consider the medical sense of these standards, as well as available historical and geographical data published about them, it becomes clear that this experience and available data can be used in other developed countries after estimation of all these standards by medical experts of these countries.

A computer model for estimating medical resource needs has already been developed and will be demonstrated during this conference. When the necessity arises, it is easy to estimate medical resource needs in financial expenditures, proceeding from the bed/day costs, doctors' incomes, etc. The development of this model for medical resource needs will help the health

manager not only to forecast needs, but also to test in advance some possible alternatives. This can be done by changing some of the parameters of this computer model, such as hospitalization rate, average length of stay in hospital, bed occupancy rate, etc.

According to the Research Plan for 1978, the IIASA HCS modeling group will begin work on the medical resource allocation model. The first version of this model was developed in 1977 on the basis of the UK experience. The UK, it should be emphasized, has had much experience in developing and applying operations research to the health care system, especially for solving resource allocation problems. In IIASA, this approach has been essentially completed, computerized, and linked with other computer models, and will be demonstrated in the course of this conference.

A combination of all these elaborated, interrelated computer submodels--population, morbidity, resource needs, and resource allocation--will be very fruitful for application in different countries.

Because decisionmakers are sometimes far removed from computer centers, the IIASA HCS modeling group, together with the IIASA computer network group and the Bratislava computer research center, is working on the remote use of this computer model. The first stage of this work also will be demonstrated during this conference.

#### NEAREST PERSPECTIVES

According to the IIASA Research Plan for 1978, the HCS modeling group will be dedicated to:

- the practical testing of this HCS computer model in the UK (Southwest Region) and Bulgaria (Silistra District);
- the mathematical description of the relationship of the health care system to external systems, taking into account the necessity for compatibility of all components.

Considering that the present simulation model is oriented to national and international level decisionmakers, the following has been planned:

- to develop further contacts with the Bratislava Computer Center and with WHO headquarters concerning the remote use of computer models and the exchange of information;
- to hold a training seminar in 1978 with participation of responsible health managers from WHO and developed countries.

## CONCLUSIONS

- The systems analysis methodology offers new possibilities for solving complex health system management problems.
- Taking into account the lack of medical information, the levels of operations research experience in different countries, and the necessity for an interdisciplinary approach in health care system modeling, IIASA is the most suitable place for such work, especially for modeling national and international problems.
- The sense of the developed model reflects the definitions of "health" and "health care system" accepted by the Fifth and Sixth WHO programs.
- Although the model is dedicated to national health care system modeling, the same methodology could be used for other hierarchical levels of the health care system.
- These methods may be useful to the World Health Organization by helping to eliminate the differences in health statistics (definitions, methods of calculation, data processing, etc.) to allow for better comparison among countries and more accurate allocation of international resources.

In addition to these positive results, there are some problems that should be discussed during this conference. First, taking into account the importance of IIASA's work for developed countries, we would ask the National Member Organizations to assist us in our modeling activity by sending us needed information and scientists, and by organizing a group responsible for checking and applying this computer model to health care management.

Second, it is necessary to ease these simulation models into use. Thus we should try to improve the mutual understanding among health managers, health care scientists, and modelers, and better coordinate the work within countries concerning the collection of scientific results and the development of different computer information systems.

## REFERENCES

- [1] Venedictov, D.D., Systems Analysis of Health Services, in N.T.J. Bailey and M. Thompson, eds., *Systems Aspects of Health Planning*, North-Holland, Amsterdam, 1975.
- [2] Klementiev, A.A., *A Computer Method for Projecting a Population's Sex-Age Structure*, RM-76-36, International Institute for Applied Systems Analysis, Laxenburg, Austria, 1976.

- [3] Shigan, E.N., *Alternative Analysis of Different Methods for Estimating Prevalence Rate*, RM-77-40, International Institute for Applied Systems Analysis, Laxenburg, Austria, 1977.
- [4] Kaihara, S., et al., *An Approach to Building a Universal Health Care Model: Morbidity Model of Degenerative Diseases*, RM-77-6, International Institute for Applied Systems Analysis, Laxenburg, Austria, 1977.

## THE COMPONENTS OF THE IIASA HEALTH CARE SYSTEMS MODEL

R.J. Gibbs

### PLANNING THE FUTURE PROVISION OF HEALTH SERVICE RESOURCES

One of the major tasks in the strategic planning of health services is to determine the future provision of an appropriate mix of resources (e.g., hospital beds, physicians, etc.). The way in which this is done (and the extent to which it is done through a central planning agency) varies from one country to another. However, in most countries strategic planning of resource provision occurs in two stages, referred to here as the "unconstrained" and "constrained" stages of planning. In the unconstrained stage, planners attempt to estimate future resource needs in terms of what would be needed to meet all anticipated demands for health care at clinically perceived ideal standards. Following this, in the constrained stage, account is taken of certain constraints, particularly economic, that limit the total amounts of resources that a country can afford to devote to health care.

A fully developed form of the unconstrained stage of health care system (HCS) planning is depicted in Figure 1. In this scheme, the estimation of HCS resource needs for a given future year proceeds as follows. A forecast of population is combined with a forecast of disease prevalence rate to yield an estimate of future morbidity--the amount of sickness in the population as a whole. This estimate can be an aggregate figure--general morbidity--or it can be disaggregated, for example, by age, sex, and disease type. The pattern of future morbidity is largely a product of nature and therefore its estimation is amenable to scientific forecasting. By contrast, the other factors involved--ideal standards\* and policies for treatment and prevention (which determine the modes of care)--are the products of the intervention of the HCS and are therefore subject to HCS policy (see Figure 1). As an example, let us consider the treatment of pneumonia. In one country or region it might be considered, on clinical grounds, that 90% of pneumonia cases need the hospital

---

\*In this paper, the term "standard" denotes the average amount of a HCS resource consumed per patient for a given treatment (e.g., 20 days for a hospitalized case of pneumonia). In some of the literature, this term is used to denote the aggregate amount of resource provision (e.g., 1.9 surgical beds per 1000 population); this latter type of quantity is covered in this paper by the terms "resource needs" and "resource supply".

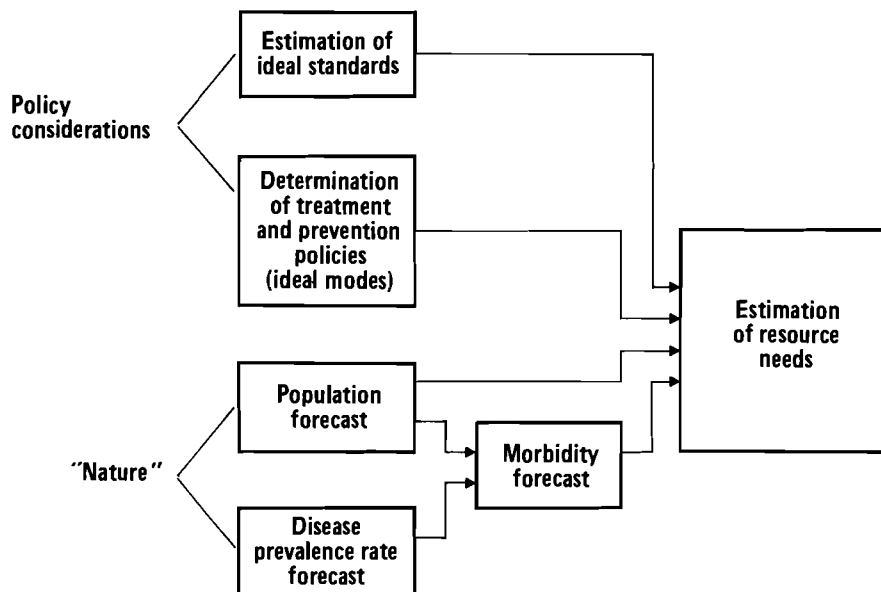

Figure 1. Planning the provision of HCS resources: unconstrained stage.

in-patient mode of care and that their average length of stay should be 20 days. However, in another country or region, where perhaps the quality of housing is better and the availability of domiciliary services is higher, a lower hospitalization rate and/or a shorter average length of stay might be appropriate. From the quantities described above--population, morbidity, standards, and policies--resource needs for the HCS can now be calculated. For example, the number of hospital beds required for treating pneumonia can be calculated from the following equations:

$$(\text{MORBIDITY}) = (\text{POPULATION}) \times (\text{PREVALENCE RATE})$$

$$(\text{HOSPITAL BEDS}) = (\text{MORBIDITY}) \times (\text{HOSPITALIZATION RATE}) \times \left( \frac{\text{AVERAGE LENGTH OF STAY}}{\text{OCCUPANCY}} \right) ,$$

where (OCCUPANCY) equals the average number of days per year a bed can be occupied. This calculation can be performed for each type of disease, and by summation the need for each resource can be computed.

The unconstrained stage in the HCS strategic planning of certain countries has been documented. For example, Popov [1] describes how it is conducted in the USSR. Disease prevalence rates are estimated by combining routine disaggregated data on sick persons contacting the HCS--registered prevalence--with more aggregate data from sample surveys of the general population (also see Shigan [2]). Prospective standards and treatment policies are determined by a combination of statistical analysis of current activity in the HCS and expert opinions on how the current performance of the HCS should be improved.

In a similar way, resource needs are estimated for the National Health Service and Personal Social Services in the UK, although there is less quantification than in the USSR of morbidity and ideal standards at a disaggregated level. These resource needs (sometimes termed "planning norms") are published by the central authority, the Department of Health and Social Security (DHSS). For example, some of the published figures on services for the mentally handicapped are displayed in Table 1 (derived from [3]).

Table 1. Planning figures for services for mentally handicapped adults compared with existing provision.

Source: Adapted from [3]

	<u>Places required</u>		<u>Places provided</u>
	Per 100,000 total population	Total England and Wales, 1969	Total England and Wales, 1969
Occupation and training:			
In the community	150	73,500	24,600
In hospitals			
For in-patients	35	17,200	30,000
For day-patients	10	4,900	200
Residential care in the community:			
Residential homes	60	29,400	4,300
Foster homes, lodgings	15	7,400	550
Hospital treatment:			
For in-patients	55	27,000	52,100
For day-patients	10	4,900	500



The figures in column 1 of Table 1 are multiplied by population figures (for 1969) to give the estimates of resource requirements (needs) in column 2. Two main points should be noted. First, the figures are based on a change in the treatment policy, which involves a shift from hospital-based care to care based much more on residential homes coupled with educational and training services. Second, the amounts of resources needed (column 2) are, except for hospital in-patient resources, much more than those currently provided (column 3).

Because no country appears able to afford to provide HCS resources at the levels of estimated needs, the actual provisions of HCS resources have to be at lower levels. Thus planners have to embark on the constrained stage of planning in order to determine a more modest set of resource provisions which (1) comply with the economic constraints, and yet (2) enable the actual performance of the HCS to come as close as possible to achieving the ideals defined in the unconstrained stage. This situation is depicted in Figure 2.

This constrained stage of planning has also been documented in certain countries. For example, Popov [1] provides comparisons between figures for the long-term HCS plan (resource needs) and figures from current plans, which are based on an understanding of the economic constraints. Some figures relating to the provision of hospital beds are shown in Table 2; note that the constrained planning figures are, in general, significantly less than the long-term need figures. Similarly, in the UK the DHSS published a document [4] that proposes a set of resource provisions for the Health and Personal Social Services in a future year which are less than previously published resource needs but which are consistent with the anticipated HCS budget. In the document an attempt is made, for each resource, to assess the relative priority of achieving a level of provision equal to the need figure; for those resources where the assessed priority is higher, the document proposes a greater rate of increase in provision, i.e., a faster approach toward the level of estimated need.

The dichotomy between the unconstrained and the constrained stages of HCS planning has been exaggerated here to ease the exposition. In real life, the two stages are probably merged to some extent; in assessing resource needs planners are bound to take some account of what levels might be afforded in the not-too-remote future. On the other hand, it would be undesirable for all planning to be dominated by the constraint of what can be afforded in the immediate future since planning might then degenerate into a process of "disjointed incrementalism", described by Lindblom [5] and others, in which there is little incentive for examining the HCS as a whole and for considering structural rather than marginal change. Accordingly, the IIASA HCS modeling task, to which we now turn, is concerned with assisting planners in both the unconstrained and the constrained stages of planning and helping to preserve the dichotomy.

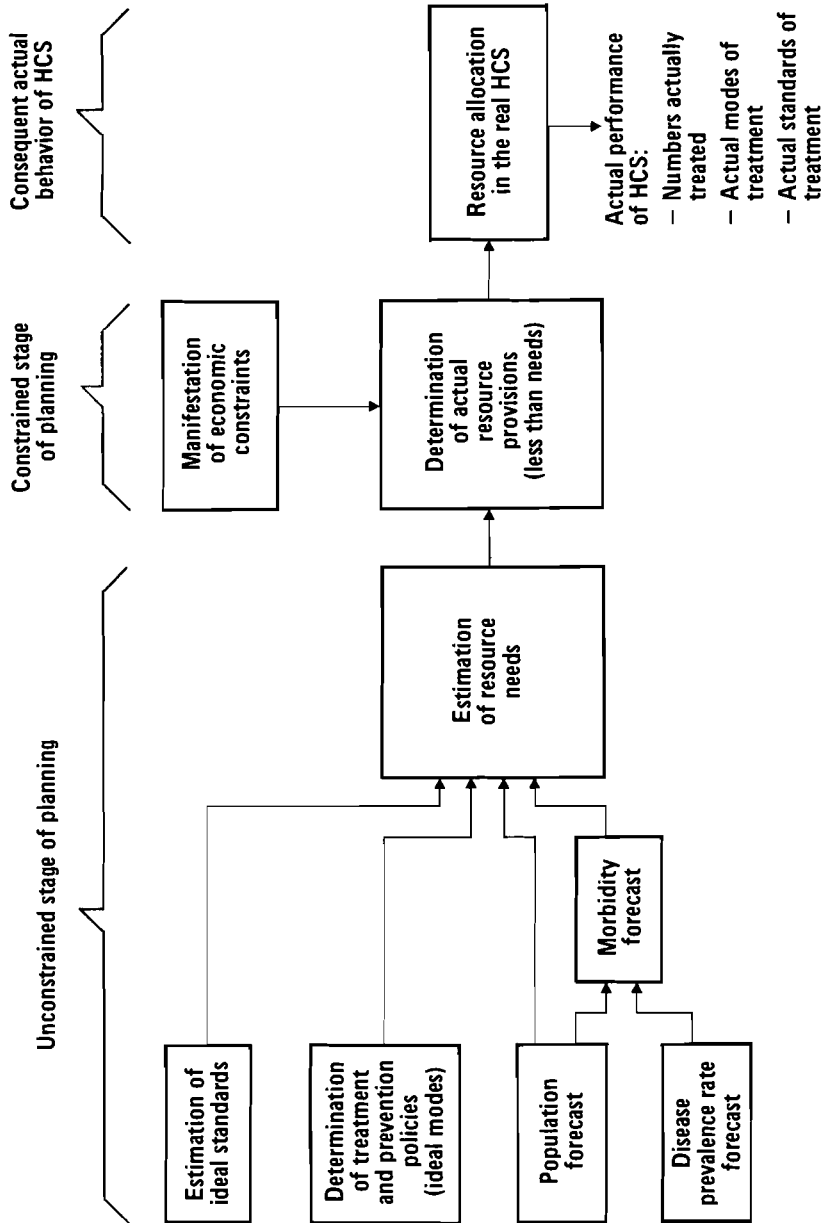

Figure 2. The context of the constrained stage in planning the provision of HCS resources.

Table 2. Requirements of urban population for hospital beds in various specialties (per 1000 population) for the USSR.

Source: Adapted from [1]

<u>Specialty</u>	<u>Plan for 1970</u>	<u>Draft plan for 1975</u>	<u>Long-term plan</u>
Internal medicine	2.59	2.69	3.4
Pediatrics (excluding com- municable diseases)	1.32	1.38	1.2
Obstetrics	0.80	0.80	0.8
Gynecology	0.67	0.75	0.8
Surgery	1.67	1.81	1.9
Neurology	0.30	0.37	0.4
Phthisiology	1.17	1.12	0.8
Dermatovenereology	0.22	0.25	0.35
Ophthalmology	0.18	0.23	0.35
Otorhinolaryngology	0.18	0.23	0.3
Communicable diseases (adults and children)	<u>0.79</u>	<u>0.80</u>	<u>0.7</u>
<b>TOTAL</b>	<b>9.89</b>	<b>10.43</b>	<b>11.0</b>
Psychiatry	<u>1.08</u>	<u>1.27</u>	<u>2.5</u>
<b>TOTAL</b>	<b>10.97</b>	<b>11.70</b>	<b>13.5</b>

#### THE IIASA HCS MODEL AND ITS APPLICATION TO HCS PLANNING

The aim of the IIASA HCS modeling task is to produce a model, or more precisely a suite of submodels, to be used by HCS planners. The long-term aim, as set out by Venedictov [6] and Kiselev [7], envisages the construction of a mathematical simulation model relating activities both within the HCS and between the HCS and other interacting systems (e.g., population, environment, and socioeconomic systems). The purpose of the simulation model is to illuminate the future consequences of alternative policies both for the HCS and the interacting systems and thus help planners examine strategic options. Within this framework, the current short-term plan for the IIASA HCS modeling task, as set out in IIASA's 1977 *Research Plan* [8] and in a recent paper by Shigan [9], is to concentrate efforts initially on modeling the HCS and its interaction with one external system--the population system.

The unconstrained stage of planning requires a model that estimates resource needs and draws on submodels for estimating population and disease prevalence. An aggregate version of such a model, AMER (Aggregate Model for Estimating Health Care System Resource Requirements), has been built by the IIASA team and is described in this volume by Klementiev and Shigan. A submodel

of the population has been developed by the Migration and Settlement Task of the IIASA Human Settlements and Services Area and is being used to the context of the HCS model. Submodels and other methods for estimating disease prevalence have been produced by the Modeling Health Care Systems Task and have been reported previously (see Kaihara, et al. [10], Klementiev [11], Shigan [2], and Fujimasa, et al. [12]).

The constrained stage of planning requires a different model that combines submodels for population and disease prevalence with submodels of resource allocation and resource supply. Such a model can be built with more sophistication. Let us start by considering a level of sophistication that is relatively simple, in concept if not in practice. We will call this the Mark 1 model.

The design and operation of the Mark 1 HCS model is shown in Figure 3. In this design a key role is played by the resource allocation submodel which simulates how the real HCS allocates scarce resources among competing demands. On the demand side it receives the following input:

- disease prevalence, from the prevalence submodel;
  - policies for treatment and prevention (modes of care);
  - ideal standards.
- } from the user  
of the model

This same set of inputs is used in the unconstrained stage of planning (see Figure 1) in calculating resource needs. The difference here is that the resource allocation submodel receives an additional input on resource supply from the resource supply submodel. This input consists of a set of resource provisions which are in general less than the corresponding resource needs but which are consistent with the given economic constraints. The resource allocation submodel then simulates how the real HCS would actually allocate these resources between competing demands. The outputs of the submodel would include the following indicators of the expected performance of the HCS, which the user can compare with the corresponding ideal quantities:

- the actual numbers of patients treated, which can be compared with the morbidity figures;
- the actual modes of care (percent hospitalization, etc.), which can be compared with the treatment and prevention policies;
- the actual standards, which can be compared with the ideal ones.

From the statement of its inputs and outputs, it follows that in simulating the behavior of the real HCS the resource

allocation submodel will have to represent at least three main processes:

- patient selection, the process that determines *who* receives treatment and preventive measures;
- mode selection, the process that determines the *type* of treatment or preventive measure an individual receives;
- standard attainment, the process that determines *how much* of a treatment or preventive measure is received.

The Mark 1 HCS model can be used as follows (see Figure 3). The user can suggest an option for resource production (in terms of building programs, physician training, etc.) which can be submitted to the resource allocation submodel via the resource supply model. He can then inspect the output of the model, compare this with the ideal HCS parameters, submit a revised resource production option, and so on until, in his view, a satisfactory output is achieved.

At this stage the reader might be critical of the implication that a HCS planner should evaluate a resource production option in terms of what might be called the "intermediate" outputs

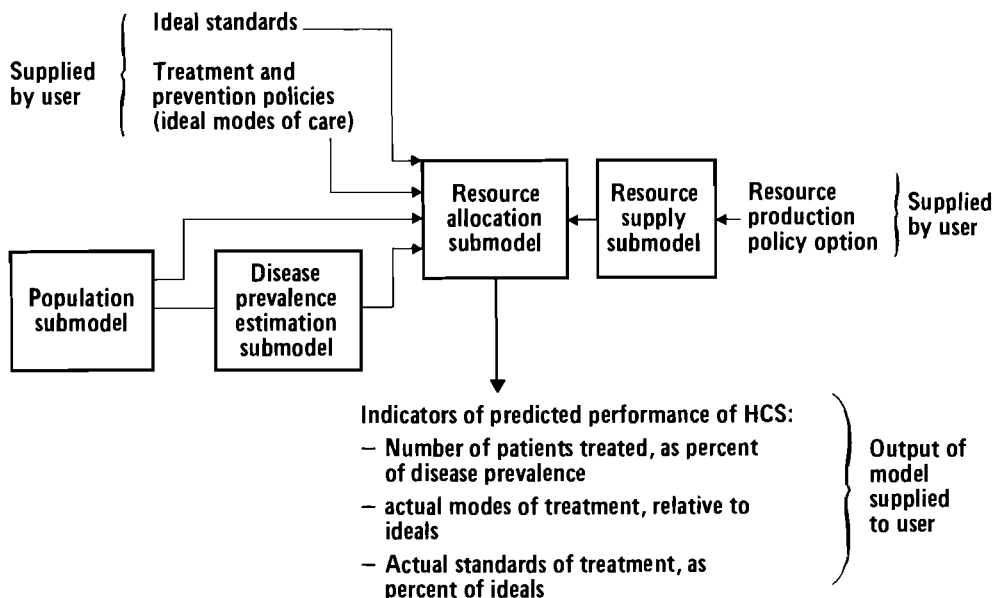

Figure 3. Mark 1 IIASA model for the constrained stage of HCS planning.

of the HCS--the numbers of people treated, the modes and standards of treatment. Surely it would be better to evaluate policies in terms of their likely impact on the future health of the population--the final outputs of the HCS?

To answer this criticism and to extend the model so that it can predict final HCS outputs, we added a fifth submodel of prognosis (Figure 4) which we call the Mark 2 HCS model. This submodel uses as input the allocations of treatments to patients (from the resource allocation submodel) and predicts the outcomes of these treatments in terms of the number of individuals who recover from sickness and the durations of their sickness, the numbers who remain sick, and the numbers who die. The ability of the Mark 2 model to estimate these final HCS outputs is not only useful to planners, but is also desirable from a scientific point of view. Only through these final HCS outputs can we examine the feedback effects from the resource allocation process to the future structure of population and morbidity. To illustrate the possible importance of such feedbacks, let us imagine that one of the resource production options being considered by the HCS planners has a major effect, via the resource allocation process, on mortality for a certain disease. This could significantly affect the population structure for a future year. In this case, the use of the Mark 1 version of the model (which

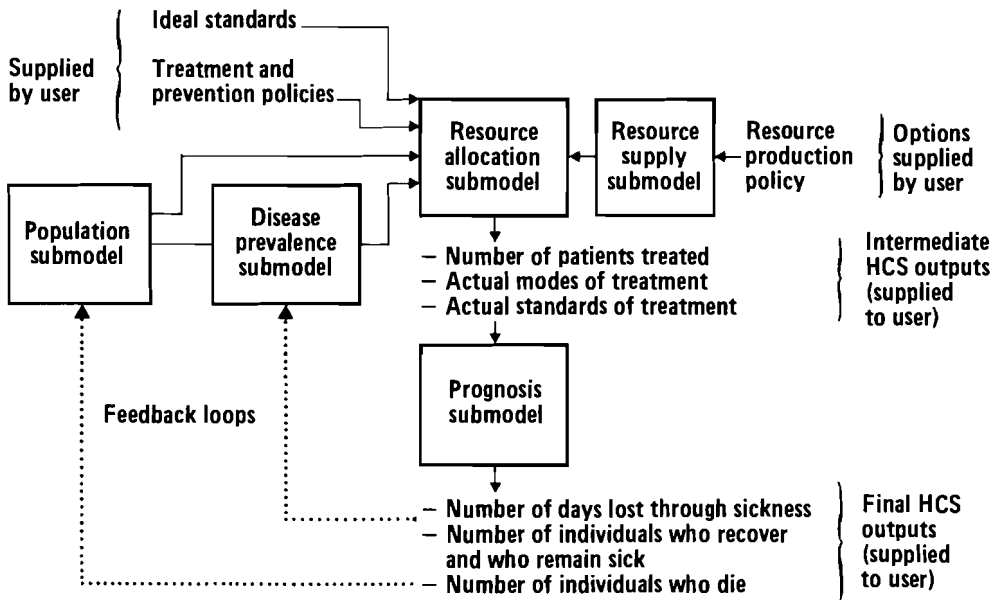

Figure 4. Mark 2 IIASA model for the constrained stage of HCS planning.

takes no account of such feedbacks) for planning HCS resource provisions for this future year could lead to error, since the model run would be based on an erroneous estimate of population for the year in question.

Thus both from the user's point of view and from the scientific point of view it is desirable to progress from the Mark 1 to the Mark 2 version of the HCS model. Unfortunately, there is a major technical difficulty in incorporating a model of prognosis. For many of the clinical procedures undertaken in the HCS, very little is known in a systematic way about prognosis, especially in the longer term. One only has to peruse the medical journals to find that eminent physicians disagree, sometimes quite diametrically, about the likely prognosis of many clinical procedures. Given this lack of data, it may not be fruitful to attempt to build a formal disaggregated submodel for prognosis. Rather, it may be more fruitful to seek expert opinion on the likely major effects, at an aggregate level, of the resource allocation process on mortality and morbidity and to use these, in place of a formal prognosis model, in the Mark 2 design to perform some simple experiments in order to discover whether there are any significant feedback effects.

Whatever the viability and desirability of the Mark 2 model, the Mark 1 version must be constructed first. Accordingly, the IIASA team has been working on the construction of submodels needed for the Mark 2 version (see Figure 3). The submodels for population and for disease prevalence estimation are available and have been mentioned above in connection with the unconstrained stage of planning. A pilot version of a resource allocation submodel is also available [13] and is described briefly in a later paper in this volume by Gibbs. Work on the resource supply submodel is planned to commence next year in collaboration with a new IIASA research task on manpower modeling. It is hoped that this task will be directed initially at modeling medical manpower.

#### REFERENCES

- [1] Popov, G.A., *Principles of Health Care Planning in the USSR*, World Health Organization, Geneva, 1971.
- [2] Shigan, E.N., *Alternative Analysis of Different Methods for Estimating Prevalence Rate*, RM-77-40, International Institute for Applied Systems Analysis, Laxenburg, Austria, 1977.
- [3] Department of Health and Social Security, *Better Services for the Mentally Handicapped*, Her Majesty's Stationary Office, London, 1971.
- [4] Department of Health and Social Security, *Priorities for Health and Social Services in England - a Consultation Document*, Her Majesty's Stationary Office, London, 1976.

- [5] Lindblom, C.E., *The Science of Muddling Through*, *Public Admin. Rev.*, 19, 79 (1959).
- [6] Venedictov, D.D., *Modeling of Health Care Systems*, in *IIASA Conference '76*, Vol. 2, International Institute for Applied Systems Analysis, Laxenburg, Austria, 1976.
- [7] Kiselev, A., *A Systems Approach to Health Care*, RM-75-31, International Institute for Applied Systems Analysis, Laxenburg, Austria, 1975.
- [8] *Research Plan 1977*, International Institute for Applied Systems Analysis, Laxenburg, Austria, 1977.
- [9] Shigan, E.N., *Systems Analysis in Health Care*, in E.N. Shigan and R. Gibbs, eds., *Modeling Health Care Systems - Proceedings of an IIASA Workshop*, CP-77-8, International Institute for Applied Systems Analysis, Laxenburg, Austria, 1977.
- [10] Kaihara, S., et al., *An Approach to Building a Universal Health Care Model: Morbidity Model of Degenerative Disease*, RM-77-6, International Institute for Applied Systems Analysis, Laxenburg, Austria, 1977.
- [11] Klementiev, A.A., *On the Estimation of Morbidity*, RM-77-43, International Institute for Applied Systems Analysis, Laxenburg, Austria, 1977.
- [12] Fujimasa, I., S. Kaihara, and K. Atsumi, *A Morbidity Sub-Model of Infectious Diseases*, RM-78-10, International Institute for Applied Systems Analysis, Laxenburg, Austria, 1978.
- [13] Gibbs, R.J., *Health Care Resource Allocation Models - A Critical Review*, RM-77-53, International Institute for Applied Systems Analysis, Laxenburg, Austria, 1977.



AGGREGATE MODEL FOR ESTIMATING HEALTH CARE  
SYSTEM RESOURCE REQUIREMENTS (AMER) \*

A.A. Klementiev and E.N. Shigan

INTRODUCTION

At the International Institute for Applied Systems Analysis, scientists from different countries are working on the development of a national health care systems (HCS) model for simulating health care activities, forecasting its development, and testing policy options. Such a model is designed to help the national-level HCS decisionmaker who must consider different versions of planning decisions and choose the best alternative.

There are several approaches to estimating HCS resource requirements. One of these, the central planning approach, is introduced in this paper.

To estimate HCS resource requirements, the following data are necessary: (1) prognosis of the population (age structure), (2) prognosis of morbidity and mortality rates, and (3) standards. In real practice, these data can be taken partly from routine statistics and other official material. But the most important data can be taken from special health surveys.

Comparison of the results of health surveys conducted in Japan, the UK, and the USSR allows us to draw the following conclusions:

- Although there are differences in morbidity and mortality indices and structures according to cause, the aggregate rates are almost identical.
- Trends over time in aggregate morbidity and mortality rates show similar patterns.
- The ratio between aggregate mortality and morbidity rates (risk ratio) changes only slightly over time.

This means that in countries where no such periodical comprehensive health surveys for estimating and extrapolating morbidity rates are conducted, or where they are very difficult from the management point of view, mathematical estimations of aggregate

---

\*For a more detailed account, see IIASA Research Memorandum RM-78-21 with the same title.

morbidity rates, based on aggregate mortality rates, are extremely useful.

In the case of aggregate modeling, it is necessary to have only aggregate standards, such as:

- percent of patients hospitalized,
- average length of stay in hospital,
- number of consultations per episode (not specified according to disease),
- bed turnover interval,
- bed occupancy rate,
- beds per in-patient doctor equivalent,
- workload (consultations per year), not specified according to medical specialty.

These standards can be used, after expert estimation, for modeling HCS resource requirements. Taking into account that these standards are control variables, the decisionmaker can alter them to fit the actual situation in his country.

#### THE AMER MODEL

Let us define the term "risk" as the ratio of all causes death rate to general morbidity rate, for a given age/sex group (stratum) of the population. We assume that, for a given stratum, risk remains constant over time; it is independent of the values of death rate and morbidity rate.

To define the relationships between needs (determined here in terms of total morbidity) and requirements in HCS resources, we use the normative approach [1]. The following types of resources are investigated: (1) total number of beds (excluding psychiatric), (2) total number of in-patient doctor equivalents, and (3) total number of out-patient doctor equivalents.

#### Model Structure

The model structure (see Figure 1) consists of four main blocks: morbidity, population, standards, and output. Input data files are indicated by double lines.

How does the model work? First, we put forward a hypothesis about the future evolution of fertility rates and death rates. Using these rates, we then forecast population age structure, which we then use together with current prevalence rates, calculated earlier from risk data, to determine general morbidity.

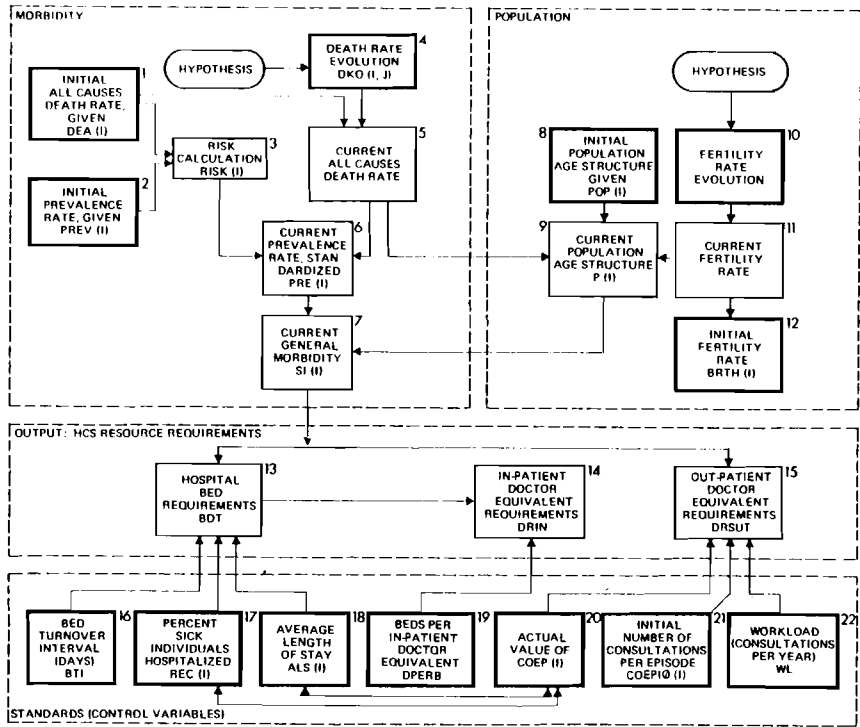

Figure 1. Aggregate model for estimating HCS resource requirements.

Now, taking into account average length of stay and percent hospitalization and bed occupancy, hospital *bed requirements* are calculated. The latter, multiplied by number of beds per in-patient doctor equivalent (standard), yields *in-patient doctor equivalent requirements*. *Out-patient doctor equivalent requirements* are determined using data about morbidity (estimated) and two standards: workload and number of consultations per episode.

Initial Data

To run the model, we need the following initial data:

- initial all causes death rate [1, DEA(I)]: number of deaths from all causes during one calendar year, given for initial year, specified by age per 1000 population;

\*The notation in brackets refers to the number of the appropriate block in Figure 1 and the corresponding variable used in the computer program.

- *initial prevalence rate* [2, PREV(I)]: number of cases afflicted with any type of disease during one calendar year, given for initial year, specified by age per 1000 population
- *death rate* [4] and *fertility rate* [11]: the evolution of these rates represents the formalization of the hypothesis about future changes in the corresponding value;
- *initial population age structure* [8, POP(I)]: population specified by age per 1000 population, given for initial year;
- *initial fertility rate* [12, BIRTH(I)]: number of live births during one calendar year, given for initial year and specified by age per 1000 population.

The above data are needed to estimate general morbidity. To calculate the output of the model (HCS resource requirements), the following standards of HCS activities are used:

- bed turnover interval, in days [16, BTI],
- percent sick individuals hospitalized from a given age stratum [17, REC(I)];
- average length of stay in hospital per in-patient, in days [18, ALS(I)];
- in-patient doctor's workload: number of beds per in-patient doctor equivalent [19, DPERB];
- number of consultations per episode for sick individuals from a given age stratum [20, COEP(I)];
- out-patient doctor's workload: number of consultations per one out-patient doctor equivalent per calendar year [22, WL].

#### Morbidity and Mortality

As mentioned above, data about morbidity and its trends can, with a certain amount of difficulty, be taken from real comprehensive studies, conducted periodically in some developed countries. But since there are only slight variances among aggregate morbidity rates, aggregate mortality rates, and the ratios between them (risk ratio) over time, it was decided to estimate aggregate morbidity data using mortality data and the risk ratio. Mortality data can be obtained from official vital statistics and demographic forecasting models.

### Standards

Although several standards exist concerning specific diseases, specialties, departments, and establishments, in the case of the AMER model it is necessary to have aggregate standards. We used several generally accepted ones, such as average length of hospital stay, percent of sick individuals hospitalized, bed occupancy rate, and bed turnover interval. These standards, published in official annual statistics on health, reflect the situation of the previous period. Therefore, they must be revised before they can be used for estimating resource requirements.

Taking into consideration the interrelationship of all subsystems within the health care system, it is necessary to incorporate the substitution effect during the modeling process. For example, what happens to the average length of hospital stay if the hospitalization rate is decreased? What effect does this have on the out-patient service? All of these substitution coefficients do not exist in routine statistics and can be taken only from special studies.

### THE METHOD

A formal description of the model is presented in this section. By definition, risks are calculated as follows:

$$\text{RISK}(I) = \frac{\text{DEA}(I)}{\text{PREV}(I)} \quad . \quad (1)$$

The all causes death rate vector,  $\text{DE}(I)_J$ , for time interval  $J$ , is determined by

$$\text{DE}(I)_J = \text{DEA}(I) \cdot \text{DKO}(I,J)^* \quad , \quad (2)$$

where  $\{\text{DKO}(I,J)\}$  is a matrix with all positive values. Elements of this matrix are determined in accordance with the hypothesis.

The standardized prevalence rate,  $\text{PRE}(I)$ , for a given age stratum can now be calculated as

$$\text{PRE}(I) = \frac{\text{DE}(I)}{\text{RISK}(I)} \cdot 10^{-3} \quad . \quad (3)$$

---

\*For reasons of simplification, the subscript  $J$  is omitted below from values dependent on it.

For a given age stratum the absolute value for general morbidity is

$$SI(I) = PRE(I) \cdot p(I) \quad , \quad (4)$$

and the respective total value is

$$SISUM = \sum_{I=1}^{18} SI(I) \quad . \quad (5)$$

For total hospital bed requirements, we have:

$$BDSTO = \sum_{I=1}^{18} \frac{SI(I) \cdot REC(I) \cdot ALS(I)}{100 \cdot DPYR} \quad , \quad (6)$$

where

$$DPYR = \frac{365 \cdot ALS(I)}{ALS(I) + BTI} \quad (7)$$

is the number of days per year a bed is occupied, and  $ALS(I)$ ,  $BTI$ , and  $REC(I)$  are the variables defined above.

The number of in-patient doctor equivalents now is:

$$DRIN = \frac{BDSTO}{DPERB} \quad , \quad (8)$$

where  $DPERB$  is the workload defined above. To calculate out-patient doctor equivalent requirements ( $DRSUT$ ), the substitution effect should be taken into account: the lower the percent of hospitalization [ $REC(I)$ ] and the shorter the average length of stay [ $ALS(I)$ ], the greater the number of consultations per episode [ $COEP(I)$ ]. A linear approximation of this dependency can be made:

$$\begin{aligned} COEP(I) = COEP\emptyset(I) - BETA \cdot [REC(I) - REC\emptyset(I)] \\ - GAMMA \cdot [ALS(I) - ALS\emptyset(I)] \quad , \end{aligned} \quad (9)$$

where COPEØ(I), RECØ(I), and ALSØ(I) constitute the initial values and COEP(I), REC(I), and ALS(I) the trial values of the corresponding control variables. BETA and GAMMA are the constant rates of substitution for percent hospitalization and bed-days by out-patient consultation, respectively. Now

$$DRSUT = \sum_{I=1}^{18} \frac{SI(I) \cdot COEP(I) \cdot}{WL} \quad . \quad (10)$$

In this section, population age structure, p(I), is implied as a given vector for every magnitude of time index J. In the model vector, p(I) is actually calculated for every J = 0,N in a separate submodel, which is described basically in Willekens and Rogers [2].

#INPUT-OUTPUT SUMMARY#

	year 0	year 5	year 10	year 15	year 20	ideal
averg lngth stay	23.80	23.00	22.00	20.50	19.00	19.00
prcntge hspitlsd	10.53	10.48	10.10	9.80	9.50	9.50
bds/inp doc eqvt	21.81	21.81	21.81	21.81	21.81	17.00
bed trnvr intrv	4.94	4.70	4.50	4.30	4.10	4.00
cnslts/otp doc/yr	7033.	7033.	7033.	7033.	7033.	6000.
bed cost/yr	3145.00	3300.00	3400.00	3500.00	3600.00	
cnslts/epsd	3.50	3.59	3.77	3.96	4.16	
*****						
bds rqrd, total	400164.	343781.	296344.	251917.	213307.	
fnds rqrd, total	1964.65	1802.11	1678.47	1564.13	1460.81	
doc eqvts rqrd	42366.	38017.	35229.	32876.	30777.	

SUMMARY

The AMER model will help the national-level decisionmaker working in an interactive regime test different policy options and select the best among them. This model also makes it possible to forecast population structure changes and mortality and morbidity trends, which are very important to health care and not only from the resource point of view.

---

\*Due to a lack of data in the recent version of the model, it was decided to set ALS(I) = ALSI, REC(I) = RECI, and COEP(I) = COEPI, i.e., they are independent of the patient's age.

Clearly, many kinds of medical information (routine, scientific, etc.) are needed to build a model like AMER. But in its turn the model also influences the development of the medical information system and needs some information that either does not exist or is difficult to obtain (substitution rates, etc.). The development of models and information systems in the health care system are closely connected.

REFERENCES

- [1] Popov, G.A., *Principles of Health Planning in the USSR*, WHO, Geneva, 1971.
- [2] Willekens, F., and A. Rogers, *Computer Programs for Spatial Demographic Analysis*, RM-76-58, International Institute for Applied Systems Analysis, Laxenburg, Austria, 1976.



## A DISAGGREGATED HEALTH CARE RESOURCE ALLOCATION MODEL\*

R.J. Gibbs

### RESOURCE ALLOCATION IN THE HCS

An earlier paper [2] reviewed the literature on models for allocating health care system (HCS) resources and concluded that the type of model appropriate to the IIASA Task was the behavior simulation type rather than one of the classical econometric or optimizing types. In particular, it was concluded that the IIASA model should take into account the preferences and priorities being used by the actors in the HCS at the point of delivery of health care. It should draw on the models of McDonald, et al. in the UK [3] and Rousseau in Canada [4], and represent the actors in the HCS striving to attain some ideal pattern of behavior within resource constraints. In this view, the resource constraints are the main means through which the planner can affect the behavior of the HCS.

Accordingly, the model proposed here is a simplification of the model of McDonald, et al. [3]. The three main mechanisms of the HCS resource allocation process--patient selection, treatment mode selection, and standard attainment--were described in my earlier presentation and were included in the McDonald model. The initial version of this model includes only two--patient selection and standard attainment. Thus it can be applied to only one sector (mode) of the HCS at a time (although it may prove possible, after further study, to extend the model to cover more than one sector). One of the advantages of the model is that the computing requirements are relatively light so that it can be readily implemented on different computers without the use of elaborate software, thus making it easily applicable to different countries. (By contrast the McDonald model, in the current form, requires relatively sophisticated software and a large computer to solve the nonlinear programming formulation.) Being simpler, the proposed model is also more transparent. Keyfitz [5], among others, has argued persuasively that with a transparent model the user can gain an insight into the workings of the model and is then more likely to have confidence in its results than with a "black box" model.

---

\*A detailed account of this work appears in Gibbs [1]; thus only a summary is given here.

The two main assumptions in the model are:

- resource provisions are never sufficient to satisfy all needs for health care;
- within constraints on the availability of resources, the actors in the HCS attempt to optimize a utility function whose parameters can be inferred from observation of their past behavior.

The function of the model is to simulate how the HCS allocates a resource among competing demands as a function of its aggregate availability. For example, below I describe an application of the model to the hospital in-patient sector, where the resource in question is hospital bed-days. But the main concept of the model, namely attaining an equilibrium between the numbers of different types of patients to be treated and the standards of treatment they receive, is appropriate to many different resources in the in-patient sector (e.g., physician time, diagnostic facilities) and to different modes of treatment in different sectors of the HCS (e.g., out-patient treatment, domiciliary treatment). Thus the model is applicable to different sectors and resources (see Figure 1).

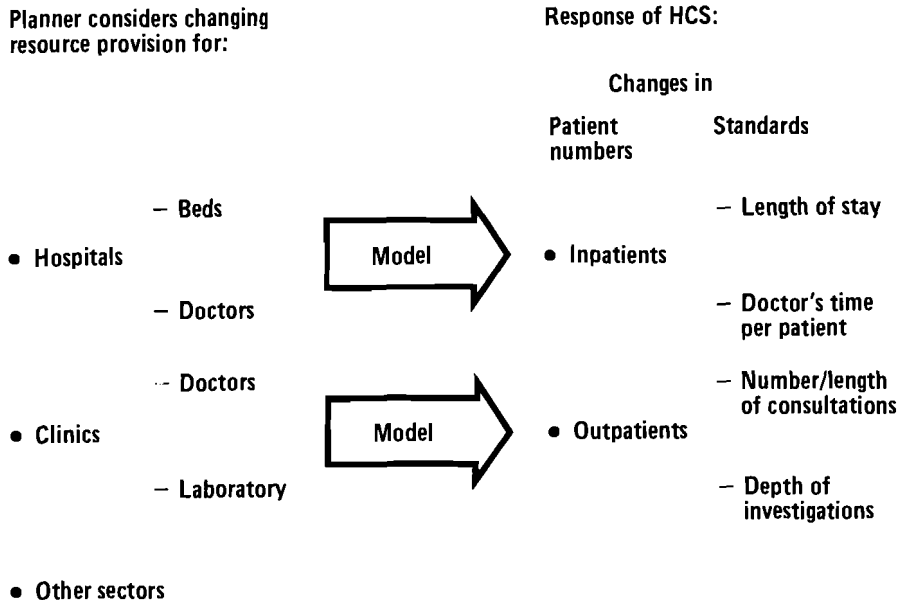

Figure 1. Model application to different sectors and resources in the HCS.

As to the example of the in-patient sector, the dimensions along which equilibrium is attained are (1) hospital admissions rates and (2) average lengths of stay. The way in which these two quantities vary as a function of aggregate bed supply differs from each other and among different types of patients. For example, acute appendicitis is a condition of such relatively high severity that a very high proportion of all such cases would be admitted to the hospital even in a region where the aggregate bed supply is low (see Figure 2). On the other hand, a disease such as bronchitis includes a proportion of patients whose condition is much less serious; consequently, the admission rate for such a disease is governed far more strongly by aggregate bed supply, i.e., in a low supply region the proportion admitted is much lower than in a high supply region (see also Figure 2). (Evidence for the forms of the curves in Figure 2 is provided later in this paper.)

Similarly, length of stay is affected by aggregate bed supply. For some diseases, the length of stay depends strongly on the clinical condition of the patient and is little affected by bed supply, whereas for some other diseases doctors discharge patients relatively early in low supply regions. In Figure 2, bronchitis and varicose veins are given as examples of these two types of diseases.

Some empirical evidence for the type of behavior described above is supplied by Feldstein [6], who estimated the elasticities of admission rates and average lengths of stay using regional cross-sectional data for England in 1960 (see Table 1). The zero value of the elasticity for appendicitis admissions is consistent with the flatness of the curve in Figure 2; similarly, the other curves in Figure 2 are consistent with the corresponding elasticity values in Table 1.

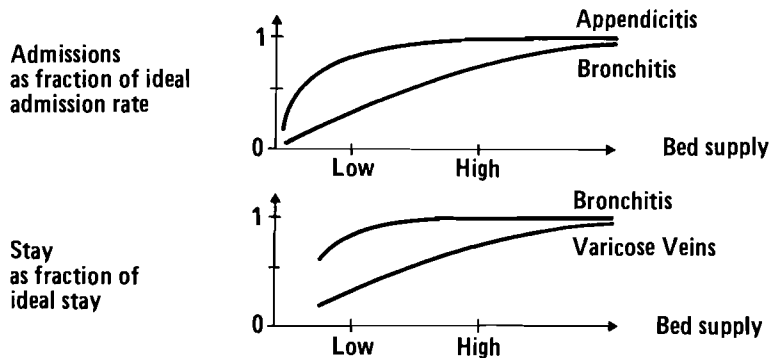

Figure 2. Application of the Model DRAM to the hospital in-patient sector.

Table 1. The effects of a 1 percent increase in aggregate hospital bed supply on admission rates and lengths of stay (empirical estimates of elasticities from Feldstein [6] for England, 1960).

	Increase in admissions (percent)	Increase in stay (percent)
Varicose veins	0.8	0.6
Hemorrhoids	0.7	0.4
Ischemic Heart*	1.1	1.1
Pneumonia	0.7	0.2
Bronchitis	1.1	0.0
Appendicitis	0.0	0.3

\*Excludes acute myocardial infarction.

In the following section, a mathematical model is proposed which attempts to simulate the type of HCS behavior described above.

#### FORMULATION OF THE MODEL DRAM

##### Definitions

###### Subscript

$i$  = Patient category (e.g., by disease type).

###### Variables

$x_i$  = Number of patients of type  $i$  admitted to hospital.

$u_i$  = Average length of stay for patients of type  $i$  who are admitted (days).

###### Data

$X_i$  = Ideal maximum number of patients of type  $i$  who need hospital treatment.

$U_i$  = Ideal average length of stay (days).

$B =$  Total number of bed-days available for occupation  
 ( $< \sum_i x_i u_i$ ).

$\alpha_i, \beta_i$  are strictly positive constants  $\forall i$ .

Hypothesis

The HCS chooses the  $x_i, u_i$  so as to maximize a utility function,  $Z$ , where:

$$Z = \sum_i g_i(x_i) + \sum_i x_i h_i(u_i) \quad ,$$

$$g_i(x_i) = - \frac{U_i x_i}{\alpha_i} \left( \frac{x_i}{x_i} \right)^{-\alpha_i} \quad ,$$

and

$$h_i(u_i) = \frac{U_i}{\beta_i} \left\{ 1 - \left( \frac{u_i}{U_i} \right)^{-\beta_i} \right\} \quad ,$$

subject to the constraint

$$\sum_i x_i u_i = B \quad .$$

Solution

It can be shown (see Gibbs [1]) that the solution to the maximization problem is:

$$u_i = U_i \lambda^{-1/(\beta_i+1)} \quad ,$$

$$x_i = x_i \left\{ \frac{1}{\beta_i} \left[ (\beta_i + 1) \lambda^{\beta_i/(\beta_i+1)} - 1 \right] \right\}^{-1/(\alpha_i+1)} \quad ,$$

where  $\lambda$  is a Lagrange Multiplier whose value can be found by numerical methods. A computer program to calculate this solution has been written and is available on the IIASA computer; it is relatively easy to transfer to other computers. The program is designed in such a way that an inexperienced user can readily use the model.

#### ILLUSTRATIVE APPLICATION OF THE MODEL

The model's applicability can be demonstrated by using 1968 data from the South Western Region of England for the six diseases listed in Table 1.

The first task in applying the model is to generate suitable parameter values. Gibbs [1] has shown that values for the parameters  $\alpha_i$  and  $\beta_i$  can be readily derived from Feldstein's elasticity estimates shown in Table 1. In a real application, the parameters  $X_i$  and  $U_i$  would probably be estimated using information on morbidity and clinical judgments. For this purely illustrative application, the estimates were obtained using 1968 data on admission rates and lengths of stay for 15 regions of England and Wales; for each parameter the highest figure from the 15 regions was selected. The full list of parameter values is given in Table 2.

Table 2. Illustrative run of model: parameter values for England and Wales, 1968.

Disease (i)	Power parameters*		Ideal levels**	
	Admissions ( $\alpha_i$ )	Average stay ( $\beta_i$ )	Admissions per million population ( $X_i$ )	Average stay (days) ( $U_i$ )
Varicose veins	1.64	3.03	12.8	15.4
Hemorrhoids	2.11	4.68	7.7	13.1
Ischemic heart	0.54	1.31	10.4	52.1
Pneumonia	2.28	9.87	21.0	19.7
Bronchitis	1.18	49.00	21.3	34.2
Appendicitis	44.40	7.06	24.8	10.1

\*Derived from elasticities estimated by Feldstein [6], shown in Table 3.

\*\*The maximum levels found among the 15 regions of England and Wales for 1968.

Now that the parameters have values, the model can be run to simulate how the HCS would simulate any given aggregate supply of bed-days (B). In the first illustrative model, the run input quantity B is set equal to 1094 bed-days, which is the amount actually used for the six diseases in question in the South Western Region in 1968. It is, therefore, instructive to compare the output from the model run with data on the actual situation in the Region in 1968. The relevant figures are presented in Table 3. The degree of agreement is reasonable enough for an illustrative run in which very crude parameter estimates have been used.

The model's application to exploring policy options for bed supply is illustrated by two further model runs in which the bed supply figure is set at two different values, one larger and one smaller than the figure 1094 bed-days, which was used in the initial run (see Table 4).

Naturally, all the output quantities increase from the low supply run to the high supply run. It is important to note that the increases vary considerably from one quantity to another. This variation can be understood in terms of the corresponding parameter values and of the curves shown in Figure 2. For example, the admission rate for appendicitis increases only slightly between the two runs, from 23.7 to 24.3 (see Table 4) and is in both cases close to the ideal level 24.1 (see Table 3); this is consistent with the corresponding curve in Figure 2. By contrast, the admission rate for bronchitis varies strongly as a function of bed supply, both in Table 4 and in Figure 2.

Table 3. Illustrative run of model for the South Western Region of England, 1968: model output for current bed supply (1094 bed-days per million population) compared with actual situation.

Disease (i)	Model output for current bed supply		Actual situation	
	Admissions per million population ( $x_i$ )	Average stay (days) ( $u_i$ )	Admissions per million population ( $x_i$ )	Average stay (days) ( $u_i$ )
Varicose veins	7.9	10.8	6.3	11.3
Hemorrhoids	5.1	10.2	4.1	13.1
Ischemic heart	4.9	28.3	4.6	40.2
Pneumonia	13.9	17.3	12.3	14.7
Bronchitis	11.2	33.2	11.8	27.4
Appendicitis	24.1	8.5	24.8	11.3

Table 4. Illustrative run of model for South Western Region of England, 1968: model output for alternative bed supply situations.

Disease (i)	Low bed supply: 800 bed-days		High bed supply: 1400 bed-days	
	Admissions per million population ( $x_i$ )	Average stay (days) ( $u_i$ )	Admissions per million population ( $x_i$ )	Average stay (days) ( $u_i$ )
Varicose veins	6.4	9.2	9.4	12.4
Hemorrhoids	4.1	9.0	5.9	11.2
Ischemic heart	3.6	20.7	6.3	35.6
Pneumonia	11.3	16.1	16.2	18.1
Bronchitis	8.1	32.8	14.2	33.6
Appendicitis	23.7	7.7	24.3	9.1

FUTURE WORK WITH THE MODEL

As with the other parts of the IIASA HCS model that are now available, the first objective is to apply the model. Indeed, arrangements have been made to try out the model described in this paper, along with other parts of the HCS model, in collaboration with research centers in certain IIASA National Member Organization countries. We hope to report the first results of these applications next year.

We also plan to develop the model so that it will represent: (1) the allocation of more than just one HCS resource within a given mode of care (e.g., beds, physicians, nurses in hospitals); and (2) the substitution between alternative modes of treatment in different sectors of the HCS (e.g., in-patient and out-patient treatment). The former does not appear to present great technical difficulty and we have already formulated an approach, but the latter may not prove to be easy. It will be difficult to retain sufficient simplicity in the formulation so as to allow efficient solution by Lagrange Multipliers (and so avoid being forced to use large and highly specialized computer programs), while at the same time capturing the essence of the problem of the balance between alternative modes of care. Only further study will reveal whether this difficulty can be overcome.



REFERENCES

- [1] Gibbs, R.J., *A Disaggregated Health Care Resource Allocation Model*, RM-78-1, International Institute for Applied Systems Analysis, Laxenburg, Austria, 1978.
- [2] Gibbs, R.J., *Health Care Resource Allocation Models - A Critical Review*, RM-77-53, International Institute for Applied Systems Analysis, Laxenburg, Austria, 1977.
- [3] McDonald, A.G., G.C. Cuddeford, and E.M.L. Beale, *Mathematical Models of the Balance of Care*, *British Medical Bulletin*, 30, 3 (1974), 262-270.
- [4] Rousseau, J.-M., *The Need for an Equilibrium Model for Health Care System Planning*, in E.N. Shigan and R. Gibbs, eds., *Modeling Health Care Systems - Proceedings of an IIASA Workshop*, CP-77-8, International Institute for Applied Systems Analysis, Laxenburg, Austria, 1977.
- [5] Keyfitz, N., *Understanding World Models*, RM-77-18, International Institute for Applied Systems Analysis, Laxenburg, Austria, 1977.
- [6] Feldstein, M.S., *Economic Analysis for Health Service Efficiency*, North-Holland, Amsterdam, 1967.

## DISCUSSION

Dr. Hartgerink began by observing that the IIASA model seemed to be based on the assumption that society needs more health care, i.e., that the number of patients, modes of care, and standards of care should be maximized. He felt, however, that there is a lack of evidence showing that more medical care is required. Examples of contrary indications include the fact that during a six-week doctors' strike in Belgium the number of deaths actually decreased; similarly, the physician/population ratio in the province of Ontario in Canada is twice as high as in the province of Prince Edwards Island, but there is no evidence that the health status of the population in the two areas differs. Dr. Hartgerink felt it might be more useful to apply models to the question of what is functioning poorly in the present health care system.

Dr. Hartgerink also pointed out that the IIASA model deals only with discrete cases of disease and treatment. In his opinion, however, much of a physician's work deals with influencing the quality of life of his patients--subjective feelings that cannot be quantified in terms of a "disease". In many cases, a physician is not even able to diagnose with certainty what is troubling his patient. Dr. Hartgerink concluded that the health care system model disregards all those episodes of illness to which a clear diagnosis cannot be attached.

Dr. Rousseau then mentioned that there is an important difference (and perhaps even no relation) between the "health system" and the "health care system". He also raised the hypothesis that if medical resources are increased, consumption will concomitantly increase without necessarily approaching saturation. In Dr. Rousseau's opinion, the decision about how much money to spend on medical care is largely of a political nature, for the public wants more health services whether or not they are in fact beneficial.

Dr. Van der Werff added that increasing the number of hospital beds is not presently a goal of many health care systems; rather, policymakers are trying to deemphasize hospital care and move toward ambulatory care.

Dr. Gibbs explained that the disaggregated resource allocation model can simulate a reduction as well as an increase in hospital beds. That is, the desired number of beds can be placed below saturation level to permit a shift to ambulatory care.

Dr. Kaihara stressed that "need" and "demand" for medical care are quite different concepts. While "need" can be deduced

from morbidity rates, "demand" depends on a multiplicity of factors, such as the education of patients. Therefore, many variables must enter into a prediction of actual numbers of cases.

Dr. Andersson suggested that models should not be used to try to find optimal strategies, but rather to improve basic knowledge about the actual behavior of the system. He felt it would be valuable to go through all possible variations of the model parameters and then to use the outcomes to analyze supply patterns, i.e., simulations could be used to deduce quantitative relations between stimulus and response.

Prof. van Eimeren pointed out three more problems in health care system modeling:

- The adequacy of "routine data" for deriving important relationships between variables. The acceptability of such data is being challenged because no changes can be detected in the data even over long periods of time. In the Federal Republic of Germany new questions about preventive medicine are constantly being addressed to routine data, but it is clear that new types of data are needed instead.
- The value of morbidity data. Such data are treated as input into models of the health care system, but they can be considered output as well. For instance, if more facilities for diagnosing diabetes are built, more cases of diabetes will be registered in morbidity statistics.
- The lack of explicit models of the planning process. If one wishes to model a system adequately, one must also take into account the self-interest of many decisionmakers. It is also necessary to consider such factors as "equity" as model constraints.

Dr. Klementiev responded that the current version of the model is restricted to selected components of the health care system, that is, the delivery of care. However, it is hoped that the model will be expanded to include the planning process, as well as socioeconomic and environmental variables.

Dr. Shigan reiterated that the model is a simple one and is not designed to answer all questions; in fact, the modeling team is working on an operational definition of a health care system at the national level. Dr. Shigan also explained that the morbidity data used in the model were taken from comprehensive health surveys rather than routine data.

Dr. Rousseau felt that the model should go beyond the current conception of morbidity and take into account medical care sought by patients who complain of such vague symptoms as "tiredness". He added that perhaps about 50 percent of all care is devoted to

such complaints and he asked how standards could be developed for such care.

Dr. Lagergren jestingly referred to the "fourth law of thermodynamics", which is based on the principle that the number of hospitalized patients will equal the number of beds. He felt that this principle reduces the value of a model that relates the population structure to morbidity and morbidity to need for beds. Dr. Lagergren also noted that a complete set of diagnoses of all cases must be available as input into the model. However, because it is not possible in 80 percent of cases to make a diagnosis, existing morbidity data based on diagnosis are very weak. The great uncertainty of such data is demonstrated by the fact that very different trends in diagnosis can be observed between hospitals. All of medicine cannot be described in terms of diagnosis.

Dr. Spies then stressed that the model as it now stands shows great progress in the field, but that it still cannot address all questions. He felt that greater flexibility must be introduced in the model to take into consideration the environment and other factors affecting morbidity. Dr. Spies also explained that in the German Democratic Republic the centralized planning process is aimed at achieving an ideal steady state, but rather at establishing priorities for meeting demands. For instance, it must be planned whether limited funds will be used to diagnose and treat such conditions as incarcerated hernias or chronic rheumatism.

Dr. Spies also pointed out the importance of taking into consideration the impacts of improvements in scientific technology. One may ask, for example, what effect the use of heart pacemakers has made on the in-patient situation; while such technology has increased the life span of patients, it has also increased their need for in-patient and out-patient care. Dr. Spies concluded that the application of the models to decisionmaking is at the present time useful, but still restricted.

Dr. Shigan emphasized at this point that the IIASA team has been working on a universal method for modeling national health care systems. It is clear that to apply such a model in a given nation, it must be parameterized specifically to reflect the conditions prevailing there.

Dr. van Eimeren interjected that certain problems cannot be studied in the context of a single country. For instance, the FRG has a higher rate of appendectomies and a higher associated mortality rate than other nations. Pflanz has interpreted this phenomenon to be the result of too much and false treatment, while other investigators claim that the epidemiology of problems related to the appendix is different in the FRG as compared with other countries. Dr. van Eimeren felt that these hypotheses cannot be tested without controlled comparative trials in Germany and other countries.

IMPORTANT POINTS MADE IN THE WEDNESDAY MORNING DISCUSSION

Dr. Bailey: Discussion has been polarized between explication of complex mathematical models and the planners' concern for the relevance of models to concrete, practical problems of decisionmaking. Is it possible for modelers and administrators to reach a common understanding?

Dr. Graham: Politicians and administrators constantly make decisions with the aid of their own informal models; it is the function of model-builders to make explicit the implicit assumptions of decisionmakers. It is not that the solutions that the models give are often wrong, but rather the questions asked.

Dr. Weiss: Does not reject the utility of models per se, but feels it is dangerous to build large generic models with global targets: Modeling efforts might be more successful if aimed at narrower objectives.

Dr. Spies: Disagrees that consumption necessarily equals availability, quoting often experienced problems of vaccination campaigns. Stressed that consumption often affected by fashion, such as cosmetic surgery; consumption can be manipulated.

Dr. Rousseau: In defense of modeling, it is aimed at understanding how a system works, to show the decisionmaker the possible consequences of his decisions. If models are able to test hypotheses successfully (such as whether the working environment influences health), then they can affect the thinking of planners. Even if the model is not implemented in a given country, it can help its planners correct their a priori assumptions.

Dr. Asvall: Feels that a model can be valuable in helping planners look at the consequences of policies, such as allocation of care. Models also give policymakers at the national level an overview of the system and bring more rationality to the decision-making process. However, modeling is not mature enough to show the impacts of policies on health outcomes. Such outcomes can only be derived from detailed studies of very specific illnesses, such as care for hemophiliacs. Perhaps such a detailed study could be undertaken at IIASA, in addition to more general modeling.

Dr. Kaihara: Models should be built on the basis of real statistics.

Dr. Gibbs: Agrees with Weiss that earlier stages of health care modeling at IIASA were too ambitious, but stressed that work is proceeding now on clearly demarcated components of the health care system, with more modest objectives. Feels that the work does not have universal usefulness, as shown by applications of the IIASA model in France and the GDR.

Prof. Fuchs-Kittowski: Modeling, however problematic, does bring a scientific approach to decisionmaking.



PART II

Health Care Systems Modeling  
By National and International Centers





## THE ROLE OF VALIDATION IN HEALTH CARE SYSTEMS MODELING

N.T.J. Bailey

### INTRODUCTION

In a wide range of quantitatively based studies in medicine and public health, some form of modeling, either static or dynamic, is in progress. Thus a great deal of rather precise dynamic modeling exists in the investigation of physiological processes. For example, statistical theory has been used extensively in the design of controlled clinical trials, and recently the use of special models has been advocated for the continuous monitoring of such trials. The study of the spread of communicable diseases has been assisted for many years by dynamic theory. Operations research and systems analysis have been regularly applied to resource allocation problems and the choice of optimal strategies in decisionmaking situations, and so on. However, the further one gets away from naturally occurring systems, especially those with an extensive physical or biological basis, and moves toward manmade systems involving a large element of administrative choice, the more difficult becomes the attempt to formulate a sound mathematical basis.

Health care delivery is precisely such a system, and the problems are compounded by the virtually unfettered growth of a health service industry that is now not only the largest service industry in the world, but also one of the largest industries in absolute terms in most countries. The massive industrialization of the health industry is geared primarily to maximizing profits for the producers, and is supported by the formation of defensive cartels, and large-scale advertising both to doctors and members of the public.

Against such a background, it is often difficult for the ultimate consumer, an individual sufferer or patient, to exercise the basic human right to health. The consumer is usually poorly informed about what health services exist, and what they are supposed to do. Medical practitioners often have no way of evaluating the flood of new drugs and technological services available to them. Consumers and practitioners alike are subjected to the overwhelming psychological and social pressures generated by the health industry.

It is the task of the public health authorities (and health planners) to provide an enlightened approach to such major problems. This is a mammoth undertaking, requiring enthusiastic and

intelligent cooperation among the medical professions, medical technologists, pharmaceutical industries, health planners, and the community of health consumers. Health planners must, therefore, be able to take a broad multidisciplinary view, including paying attention to the constraints imposed by both health economics and a variety of nonquantifiable human values.

In such a context, good policy decisions and the selection of reasonable strategies must be based on appropriate forecasting techniques that allow approximate calculation of the consequences of any particular choice. Reliable quantitative analysis must be based on a sound understanding of the forces at work, and this inevitably entails developing suitable models of the underlying mechanisms. However, for this kind of scientific approach to the problems of health care delivery to work, we must be able to tell whether the models are good or bad, whether we can believe in them or not, and how to improve their effectiveness.

The following discussion attempts to bring out the major points in facilitating the validation of such modeling in its application to the better understanding and control of health care delivery systems.

#### TYOLOGY OF MODELING

Modeling, even in explicitly mathematical terms, has been with us since at least the time of the Ancient Greeks. The pace began to accelerate in the seventeenth century, not only in astronomy and physics, but also in work on what we would now call medical statistics. Since that time, techniques and applications have been continuously advanced and are now advancing at an even greater rate. Although some form of modeling has always been at the heart of all quantitative scientific work, it is only recently that the word "model" has been given the enormous explicit emphasis that it bears today. As a result, "modeling" is now a word with which to conjure, and it consequently runs the risk of becoming a devalued concept. Accordingly, certain basic distinctions must be made between a number of logically different types of models, and between various levels of applications, if we are to have a sufficiently clear idea of what we are talking about, what we intend to do, and whether or not we are being successful. It is not the intention here to develop a minutely structured and academically oriented typology, but to highlight the main concepts that have important practical consequences for concrete applications. The classification has been discussed in greater depth elsewhere [1], and does not in any case claim to be unique [2].

First, the distinction between *deductive* and *inductive* reasoning is an important one. In a modeling context, "deductive" work means that the basic assumptions are given, including model structure, parametric values, and unavoidable constraints; our concern is to elucidate the logical consequences of the assumptions, in order to exhibit the detailed behavior of the system

that has been modeled. Such an approach is invaluable in purely theoretical work to clarify assumptions, resolve conflicting ideas, calculate qualitative implications, examine sensitivity of results to possible changes in assumptions, etc. A similar situation may also arise when administrative action is required: there is no time for further research, but at least assumptions can be tested for incompatibility and the practical consequences worked out for any proposed choice of strategy, provided that certain basic premises are accepted. This may easily arise when a committee has to review the status quo and make the best recommendations it can within a limited period of time.

In scientific work, on the other hand, there is a much stronger emphasis on "inductive" work, where we start from empirical data and then look for explanations or models that somehow "fit" the data. Naturally, a good deal of deductive reasoning is also entailed, but the process as a whole has a primarily inductive flavor.

Another dimension of practical relevance is the hierarchical level to which modeling is applied. Thus there is what we might call the *technical level*, which covers the traditional scientific fields of endeavor (e.g., molecular biology, immunology, biochemistry, physiology) where the emphasis is on aspects of the individual organism, as well as on population phenomena in demography, evolution, ecology, epidemiology, etc. The leitmotiv here is scientific understanding, first for its own sake and, second, as an aid to the control of natural processes.

The *operational level* deals with operations research and systems analysis, seen as methodologies for handling the administrative and executive problems arising in the manmade systems referred to in the Introduction. Much of this deals with organization, management, decisionmaking, and the like. In the health field, there may be anything from a small-scale operational study on the design of an operating theater to a large-scale investigation of a country's health care delivery system. The need for a scientific approach is no different from applications to the technical level, but the existence of special factors such as economics, cost-benefit analysis, resource allocation, decision-making, and the existence of psychological and moral and social constraints entails a substantially different field.

Sometimes an *information level* can be distinguished which deals with the flow and communication of information needed for decisionmaking. This is often regarded as a part of operations research, where the construction of a preliminary flow chart linking the components of the system to be studied is called a "communication model" and is seen as a prelude to the development of a full system dynamics model. On the other hand, the elaboration of a specialized managerial instrument to ensure that administrative authorities have the right information, in the right place, at the right time implies a fundamental distinction between such an information system (with its implicit information model)

and an operations research model portraying the dynamic complex of interactions between natural phenomena and human decisionmaking.

Finally, it is convenient to identify a top *policy level* where administrators are dealing with the broad strategic problems of public health, including such matters as medium-term and long-range planning, and covering large regional, national, or even international geographical areas. Activity on this level can affect the well-being of literally millions of people. It is, moreover, especially susceptible to lack of information, subjective impressions, and the making of decisions at short notice under intense psychological and political pressure. Leisurely scientific analysis is rarely possible, and may in the nature of things continue to be extremely difficult. Nevertheless, the development of more quantitative work is urgently needed to enable relevant data to be readily assimilated and the probable consequences of different strategy choices to be rapidly evaluated.

Although at present most policy analysis involves little more than an analysis of constraints, Majone's [3] remark, "Policies are, in fact, tentative theories", provides a starting point for a genuinely scientific approach. It should, therefore, be possible to develop policy models that, having due regard for the special difficulties and constraints arising in policymaking, would be able to make practical contributions.

Certain other aspects of model classification might be mentioned briefly, such as the distinction between models that essentially describe only the surface phenomena of a black box system in a statistical way and those that are capable of depicting explicitly the underlying mechanisms. In the more philosophical literature [4], this is the distinction made between "positivism" (or "functionalism") and "structuralism". Another feature often stressed is the difference between "deterministic" and "stochastic" models. Vitally important though this may be, it is very much a matter of detail, depending on whether probability elements are likely to be of practical importance or not, given the degree of approximation we are working with.

#### TYPES OF VALIDATION

Proper use of the scientific method requires that speculations suggested by experience be clearly formulated in terms of specific hypotheses, and that these hypotheses be carefully tested and validated by a further appeal to empirical observation. There is no reason why health care systems modeling should be excluded from this process, but before examining the implications for public health applications, let us first distinguish between different kinds of validation in a simple way.

### Clarification of Concepts and Thought

First, there is the somewhat subjective criterion of the usefulness of any intellectual activity and, of course, of modeling in particular with regard to the clarification of ideas and concepts, the search for insight, the formulation of new and fruitful approaches, and so on. Many people working on health care modeling would claim that this criterion is frequently satisfied, while others think it is an expensive, useless waste of time, but we are concerned with positive opportunities for making progress. In any case, there is no disputing that modeling has been extraordinarily successful in many branches of physics, chemistry, and biology. The problem here is, what can it really do in public health?

### Logical Soundness and Coherence

Once concepts and general ideas have been sufficiently clarified, it is possible to undertake much more specific theoretical investigations. Mechanisms and processes must be described and modeled in terms that are not too unrealistic, but yet are simple enough to yield to logical and mathematical analysis. This already constitutes a further degree of validation: models may be rejected because they are hopelessly oversimplified or because they seem too complex to yield theoretical insight at the present stage.

The properties of the models must be deduced from the basic specifications. In many cases, this means investigating broad qualitative behavior and comparing this with what can be regarded as known. A model would be faulted if it implied oscillatory behavior or the existence of a threshold where none occurred in practice. Similarly, if we are looking for steady states, we need to know how many equilibria the model entails and whether they are stable. Some models are mathematically intractable as they stand, but will yield to analysis in terms of known functions if minor changes are made in the basic formulation. Again, if a computerized solution of the underlying equations or computerized simulation studies are envisaged, we want to know the mathematical reliability of the procedures. Spurious results can easily be introduced through failure to pay proper attention to the requirements for valid numerical analysis.

Aspects such as these must be properly investigated if sound, internally coherent models are to be developed having a well-understood structure that can be used as a basis for practical applications.

### Statistical Fitting

Broad preliminary discussion and some theoretical investigation should hopefully lead to specific models and hypotheses

that can in some sense be tested against empirical observation. This has been routine for centuries in such exact sciences as astronomy and physics. Small discrepancies between theory and observation can often be attributed to "errors of observation", and eliminated simply. During this century, applications have been made increasingly to biology and medicine. In these areas, there is apt to be a large degree of natural variability that cannot be handled by a simple "theory of errors". Special statistical techniques have had to be developed involving the central concepts of parameter estimation and significance testing. First developed in the contexts of agriculture and experimental genetics, the principles of experimental design and hypothesis testing are almost universally applicable, but modified according to circumstances.

Essentially, a hypothesis is tested by first estimating unknown parameters in the model, using statistically efficient methods. Then, if there is sufficient residual variation, we can test whether any discrepancy between theory and observation is larger than could reasonably occur by chance, assuming the hypothesis to be true. If, on appropriate criteria, the discrepancy is too large to be acceptable, we have a "statistically significant" result and the "goodness-of-fit" test has failed. The hypothesis must then be rejected, or at least modified and retested. Models themselves can be tested in this way by formulating hypotheses so as to include some or all of the essential features of the model.

If the result of such a test is "statistically nonsignificant", then the hypothesis of model continues, at least for the time being, to be credible. Of course, if the data are not sufficient, it may not be possible to fault wrong hypotheses or inaccurate models. But with sufficient data an effective degree of discrimination can be achieved. In particular, it is always encouraging if there are several models available and all but one are rejected by an appropriate significance test.

Where models are simple and contain only a few parameters, the foregoing procedure should certainly be followed. But where models are very complex, as many systems models are, it may be impracticable to test the model as a whole. Such models are much more like bodies of scientific knowledge constituting a theory that has been built up gradually, and thus such models must be tested piecemeal. Individual components of the system should be subjected to proper statistical tests, and the validity of the system as a whole can be checked from time to time by its predictive power under certain crucial circumstances.

#### Predictive Power

When models pass the appropriate statistical goodness-of-fit criteria, based on adequate data, we begin to have more confidence in them, especially when rival explanations have been rejected by

the same procedures. However, in any true scientific approach more retrospective explanation is not enough. Repeatability of experiments or observations is essential, the form of which depends on circumstances. It could be that the constraints and conditions that held for past experiments or observations are not exactly reproducible, which is likely to be the case with large complex systems. However, the essence of the requirement can be met if appropriate predictions can be made as to what will be observed under specified conditions. "Repeatability" then means the capacity to make verifiable predictions in this sense.

In certain highly structured experimental designs of the classical type, e.g., multiple regression or factorial experimentation, it is possible to set statistical confidence limits for the range of new observations relevant to a specific combination of independent variables or contributory factors that have not previously occurred. If the observations do not fall within the appropriate confidence limits, a statistically significant failure of the prediction is established. This principle can be widely applied to the testing of all kinds of complex models, though practical examples are difficult to find.

It is of particular importance in the use of system dynamics models, such as those developed and advocated by Forrester [5,6,7] and further elaborated on a world level by Meadows, et al. [8] and by Mesarovic and Pestel [9]. Unfortunately, much of this work, while fulfilling many of the preliminary requirements for clarifying concepts and thought, has not been subjected to full logical analysis and validation, nor has proper statistical fitting to empirical data been carried out. Moreover, the predictive potential of modeling has been promoted as a serious guide to current policy *before* any validation based on verifiable predictions has been established. It is not surprising that damaging criticisms to this whole approach have been widespread. Nevertheless, the present sequence of rational steps could be followed to build up a reliable and credible body of knowledge.

#### Consumer Satisfaction

If the preceding scheme were followed, we should be gradually amassing a legitimate instrument for practical action. However, a final phase must not be forgotten. No matter how intrinsically good our modeling is, it will not be practically applied unless it can be understood, at least generally, by those decisionmakers whose work it might facilitate. Like the clarification of concepts and thought, this criterion is also somewhat subjective in character; nevertheless, it must be taken seriously. For if the ultimate consumers of modeling, i.e., here public health decision-makers, are not sufficiently convinced of the usefulness of the approach, they will simply ignore it.

More thought should probably be given to this aspect. Obviously, one cannot carry out a sophisticated statistical trial

of "decisionmaking with modeling" versus "decisionmaking without modeling". But it should be possible to evaluate in a general way the consequences of using models that have explicitly gone through the five stages referred to it, as compared with situations in which such an approach has not been used.

### Computerization

Generally speaking, this paper puts no special emphasis on the use of computers as such since we are more concerned with the methodological problem of how to validate the modeling process. Nevertheless, complex models are apt to require a computer, either to solve numerically complicated sets of equations or to carry out computerized simulations. However, the ease with which a computer can be applied to immensely complex systems and to ability to discharge vast printouts often obscures the fact that the underlying models have not been properly examined and verified. As a result, those using the printouts might well not believe them if they were more aware of what lay behind the scenes. For a discussion of verification in the context of computer simulation modeling, see Naylor and Finger [10], together with subsequent critiques in the same journal. Although primarily related to industrial and economic applications, this paper also has wider implications for other fields.

### PUBLIC HEALTH APPLICATIONS

In the area of public health, there has been a great deal of successful modeling on what we have called the technical level, whether this be in physiology, pharmacology, clinical science, controlled clinical trials, epidemiological surveys, and so forth. And on the operational level, small-scale operations research approaches to such subjects as hospital ward design, out-patient appointment systems, mass health screening, cost-benefit analyses of expensive and specialized equipment have also been very effective. In both groups of applications, it would not be difficult to show that the validation criteria in the previous section can be largely satisfied.

It is only when we come to the larger systems, particularly those concerned with complex health services, that major difficulties begin to arise. Recent reviews of current developments in the health planning field [11,12] illustrate the wide range of systems applications available, together with the elaborate modeling techniques that seem to be frequently required. While much stimulating work has been done to clarify thought and to suggest exciting new lines of applied research, much remains to be done, both to validate the modeling with regard to the previously mentioned criteria of logic, statistics, and prediction, and to provide comprehensible and usable administrative instruments that will satisfy public health decisionmaking consumers.



Many attempts to apply large-scale systems approaches to health planning and health care delivery systems have been rejected (see, for example, Hoos [13]). Several proposals have foundered on the modelers' inability to answer the simple questions: Why should I believe in your particular model?, Does it work in practice?, and Will it be cost-effective? I am suggesting that tentative models must first achieve a sufficient degree of validity in acceptable scientific and statistical terms. Then they can be examined further for possible cost-effective applications. But if an enormously complicated econometric type of model, incorporating vast numbers of mathematical equations, is propounded to portray a health care system in which there are hundreds of compartments, thousands of interactions, and countless parameters to be estimated, then the absence, even the impossibility, of a substantial amount of validation as indicated in the previous section is almost certain to lead to failure, sooner rather than later.

The only feasible way to proceed is to regard the construction of a large-scale comprehensive system as something that must be done gradually and in stages, like the putting together of a whole body of scientific knowledge constituting a general theory. It should be possible to check out individual components of the system in some detail, e.g., quantitative technical models of disease incidence and spread, demographic changes, health manpower, and drug supplies. Retrospective statistical validation on past data, as well as prospective predictive validation on new data, are required. As the comprehensive model is put together, proper attention must be paid not only to the interfacing of the various submodels, but also to the inevitable constraints imposed by economics, social behavior, political necessity, and so on. The overall systems model must then be validated. While overall replication for purely statistical testing may be impossible, there will be many opportunities for validation with respect to clarification of thought, logical coherence, partial statistical fitting, prediction in special circumstances, and practical assistance to decisionmaking and policy planning.

The mention of economic, social, and political constraints above also implies that the consideration of even larger systems may become unavoidable, necessitating the use of intersectoral models in which health is only one, albeit important, sector.

## CONCLUSIONS

In the context of this conference, the foregoing discussion, which is oriented toward all or any public health applications, has specific implications for health care systems modeling. Thus all such health care models should be explicitly reviewed with regard to the types of validation required. Purely theoretical studies may have great value in clarifying thought and providing general insights. But if they are to provide a sound basis for practical developments, they must also be subjected to logical

and quantitative analysis in order to lay bare possible internal contradictions as well as unforeseen and unwanted qualitative behavior. This is especially important if the modeling is to be subjected to intensive computerization, with the risk that printouts will be regarded as an immediate guide for decision-makers. In addition to these primarily deductive modes of analysis, it is essential to consider the inductive problems of fitting the models to actual data arising from certain specific, well-defined health care systems. Similarly, the advance to the subsequent stages of testing actual predictive power and practical usefulness to decisionmakers must be planned and carried out.

A rigorous application of the appropriate forms of validation is vital to building up an established body of quantitative knowledge that provides both theoretical insight and reliable tools for practical decisionmaking.

#### REFERENCES

- [1] Bailey, N.T.J., *Mathematics, Statistics and Systems for Health*, Wiley, London, 1977.
- [2] Jantsch, E., Forecasting and Systems Approach: A Frame of Reference, *Management Science*, 19 (1973), 1355-1367.
- [3] Majone, G., The Feasibility of Social Policies, *Policy Science*, 6 (1975), 49-69.
- [4] Gardner, H., *The Quest for Mind*, Knopf, New York, 1973.
- [5] Forrester, J., *Industrial Dynamics*, MIT, Cambridge, Mass., 1961.
- [6] Forrester, J., *Urban Dynamics*, MIT, Cambridge, Mass., 1969.
- [7] Forrester, J., *World Dynamics*, Wright-Allen, Cambridge, Mass., 1971.
- [8] Meadows, D.H., D.L. Meadows, J. Randers, W.W. Behrens, *The Limits to Growth*, Universe Books, New York, 1972.
- [9] Mesarovic, M., and E. Pestel, *Mankind at the Turning Point*, Hutchinson, London, 1974.
- [10] Naylor, T.H., and J.M. Finger, Verification of Computer Simulation Models, *Management Science*, 14 (1967), B92-B101.
- [11] Bailey, N.T.J., and M. Thompson, eds., *Systems Aspects of Health Planning*, North-Holland, Amsterdam, 1975.
- [12] Venedictov, D.D., ed., *Health System Modeling and the Information System for the Coordination of Research in Oncology*, CP-77-4, International Institute for Applied Systems Analysis, Laxenburg, Austria, 1977.

PROBLEM-ORIENTED GLOBAL MODELING: DEVELOPING  
A HEALTH CARE-ORIENTED SIMULATION MODEL

A. Petrovsky, P. Kitsul, W. Olshansky, and A. Yashin

The need to foresee the results of actions taken simultaneously by many countries has generated a new direction of systems analysis called global modeling. Existing global models have two kinds of submodels--productive subsystems (e.g., industry, food and agriculture, mining and energy) and nonproductive subsystems (e.g., education, health care, social welfare, law enforcement.

Global models are intended to determine general trends in the socioeconomic development of different countries [1-4]. Nevertheless, the global nature of these models does not permit close analysis of how regions and particular subsystems function. A significantly large number of autonomous models of subsystems exist, but these do not allow for the effects of processes outside these subsystems.

Thus models are needed that allow detailed analysis of decisionmaking within certain subsystems, but that, at the same time, recognize the effect of processes in "external" subsystems. Such models could be called problem-oriented global models.

Although models of the productive subsystems have been thoroughly developed, the methodology for building models of nonproductive systems is still lacking. The importance of nonproductive sectors for regional and global development lies not only in their effect on the economic indices of productive sectors, but also in their contribution to the sociocultural background (measured with appropriate indicators) from which a society evolves.

One of the important subsystems is the health care system which not only affects the set of indicators characterizing the development of a certain region but is itself influenced by exogenous socioeconomic factors.

Health care-oriented global models, while representing regional specificity, should also possess a certain amount of universality [5] to show generic properties. We have developed a simulation model, "Population-Health Care", which recognizes the following kinds of interaction with the external economic ecological environment:

- the gross regional product and its reproduction,
- health care costs and labor force reproduction,

- food supply,
- environmental pollution,
- interregional links.

This work was carried out along the methodological guidelines of the Scientific Council for Systems Research in Biology and Medicine of the USSR National Committee for IIASA [5].

#### THE MODEL'S STRUCTURE

In our health care system model, mathematical techniques, very similar to those used for certain demographic models, are used to describe the population dynamics. This description relies on partial differential equations of a special type. In health care system modeling, this description becomes very involved because health status indicators must be incorporated into this structure, in addition to the sex-age structure of the population [6].

Population is classified into age-health groups. The number of age groups depends on the desired specificity of the age-pyramid.

The minimal number of health categories is four:

1. healthy population;
2. the unaware sick--those who are not aware of their disease or those who are aware but do not require medical help;
3. the sick who are aware of their disease but are not treated;
4. the patients who are treated.

Categories 2-4 can be further subdivided according to types of disease, stages of disease, types of required service (in-patients, out-patients, custody, etc.) [7,8].

When initially developing a health care model, it is reasonable to develop one that requires the least amount of information. In a certain sense, this requirement is fulfilled by the above four categories.

Atsumi and Kaihara [9] have studied such a model, which was developed to analyze the exchange rates among the categories using the statistical data available in Japan, and to forecast the future needs of medical care in Japan. It did not study the allocation of resources in health care or the feedbacks from those people in each health category to the exchange rates among the

health categories. However, consideration of these problems would make it possible to study some subtle nonlinear effects due to, say, limited capacities of the health care system, health care availability, and workload, etc.

Our model describes age-health dynamics by a system of  $K$  partial differential equations:

$$\begin{aligned} \partial u(i, x, t) / \partial t &= -\partial u(i, x, t) / \partial x + \sum_{j=1}^{j=K} q_{ij}(x, \vec{u}, \vec{r}, R) u(j, x, t) \quad , \\ u(i, x, 0) &= f_i(x) \quad , \quad (i = 1, \dots, K) \quad (1) \end{aligned}$$

$$u(i, 0, t) = \sum_{j=1}^{j=K} \int_0^T \phi_{ij}(u, x, t) u(j, x, t) dx \quad ,$$

where  $K$  is the number of health categories (including the dead);  $T$  is the maximum duration of life;  $u(i, x, t)$  are the people in the  $i$ -th health category of age  $x$  at time  $t$ ;  $q_{ij}(x, \vec{u}, \vec{r}, R)$  are the probabilities of transition from category  $j$  into category  $i$ , depending on the vector of health-care resources  $\vec{r}$  and the time vector  $\vec{u} = [u(1, x, s), \dots, u(K, x, s)]$ ,  $0 \leq x \leq T$ ,  $0 \leq s \leq t$ ;  $f_i(x)$  is a given initial condition;  $R$  is the external factors; and  $\phi_{ij}(u, x, t)$  is the birth rate classified by age and health categories.

Equations (1) are solved by the method of characteristics. The continuous age  $x$  is quantified so that the population is divided into  $N$  age groups.

The transition coefficients among the health categories are dictated in the model by the current medico-demographic structure of the population, the resources for health care (i.e., prevention, medical education, professional medical education, detection measures, intensive treatment, progress of medical science, etc.) and by exogenous factors (i.e., life standards, the nutrition level, the environment pollution level).

To work with the model, one has to specify the initial and boundary conditions, i.e., the medico-demographic characteristics of a region. The transition coefficients are partly specified in advance and are partly varied by the decisionmaker when working with the model. This work consists of reviewing sets of numeric characteristics of population health as a function of various kinds of the transition coefficients variations.

To analyze health care activities and to obtain reasonable controls, one must interact with this system bearing in mind the external systems. This can be done in two ways: (1) by developing a closed loop model of the health care system, or (2) by specifying the external actions in compliance with a scenario.

The natural evolution of the model goes along the lines of progress in global modeling: at the first stage, it is a generalized model (somewhat analogous to models by Forrester and Meadows [1]); at the second stage, it is a regionalized model (an analog of one of the levels in the Mesarovic-Pestel model [3]). The regionalized model more adequately represents the mixed central-local allocation of investments in health delivery existing in some countries.

#### EXTERNAL SYSTEMS

Our health care systems model used the following input from external systems: gross national/regional product per capita, environmental pollution level, nutrition level, and health care costs. How these factors influence population parameters calls for further investigations. At the early stages of our model, we used the factors of environmental pollution and nutrition level in the same fashion as the Mesarovic-Pestel model [3].

Outputs of the health care system affecting the external systems are the active labor resources and the index of health care social performance (see below).

To obtain a closed loop model, we built a model for the external systems and a set of controls (scenarios). The easiest way to develop such a model is to use production functions that formally relate resource productivities and amounts to the product. Labor resources, which are divided among industry, services, and agriculture, enter the associated production functions. Production functions determine the gross regional product which is divided into investments in industry, service, and agriculture, and consumption. The gross regional product provides the investments in health care which should be intelligently allocated among the services and functions of the health care system itself.

From the point of view of health care, industry determines the amount of environmental pollution and agriculture determines the nutrition level. The minimal nutritional needs specified meet the conditions of life preservation recommended by the World Health Organization. Actual food needs increase with the gross industrial output per capita. A comparison of nutritional needs with food production and availability shows the nutritional deficit that affects morbidity and death rates.

#### HEALTH CARE MANAGEMENT

In our model, health care costs are divided into investments in the prevention/treatment activities of disease prevention and

medical education, detection of the sick, and treatment of the sick, and the investments in management, equipment, professional medical education, and medical science.

In allocating the resources for prevention, detection, and treatment, priorities are specified for the resources earmarked for each age group. For instance, the resources allocated for children's health care are greater than those for the other age groups, thus decreasing child morbidity.

The allocation of resources also allows for some indicators of public opinion reflecting social tension due to inadequacy of health delivery.

ECONOMIC EFFICIENCY OF HEALTH CARE

The production function of industry [1] is the following:

$$Y_{t+1} = CK_t^m(K_t, Y_t/P_t, L_t) \quad (2)$$

$$m(K, Y/p, L) = \begin{cases} 1, & L^*/L \leq 1; \\ (1-h)[\cos b(L^*/L - 1) + 1]/2 + h, & 1 < L^*/L \leq \pi/b + 1; \\ h, & L^*/L > \pi/b + 1, \end{cases} \quad (3)$$

$$L^*/K = \Lambda/(Y/p - Y_0), \quad (4)$$

where  $t$  is time;  $y$  is regional industrial output;  $C$  is the output-capital ratio;  $K$  is capital;  $m(\cdot, \cdot, \cdot)$  is the capital utilization factor;  $P$  is total population;  $L$  is active labor force supply;  $L^*$  is labor force demand;  $h, b, Y_0, \Lambda$  are empirical constants;  $\pi$  equals 3.14.

Investments in health care result in a larger active labor force  $L$  because of decreased disablement and increased life expectancy at birth:

$$L_t = \sum_{i=0}^{i=K} \int_0^T \lambda_i(x, S_t) u(i, x, t) dx, \quad (5)$$

where  $\lambda$  is labor activity and  $S$  is the index of social performance of health care. Health care costs  $I_{HC}$  may also increase the labor-active fraction of the population by improving the sociocultural indicators of the region.

It is natural to define the economic efficiency  $E_e$  of increases in health care costs as the ratio of the regional industrial output increment since the increment of health care costs  $I_{HC}$  to these costs at the given level of health care costs  $I_{HC}$ :

$$E_e = \left( \frac{\partial Y}{\partial I_{HC}} \right)_{I_{HC}} \quad (6)$$

Within the framework of equations (2)-(4), the efficiency  $E_e$  may be other than zero only when the employment ratio  $L^*/L > 1$ . With an employment ratio of  $L^*/L \leq 1$ , investments in health care can only be justified by the increased social tension that would result from a deterioration of sociocultural indicators if these investments were not appropriated.

#### SOCIAL EFFICIENCY OF HEALTH CARE

The social tension that would result from inadequate health care is specified by the index of social performance of health care  $S$ :

$$S_t = \left[ (LE/70) \sum_{i=1}^{i=K} \int_0^T \sigma_i(x) u(i, x, t) dx \right] / \left[ \sum_{i=1}^{i=K} \int_0^T u(i, x, t) dx \right] \quad (7)$$

where  $\sigma_i$  are empirical coefficients and  $LE$  is life expectancy at birth.

It is natural to determine the social efficiency  $E_s$  of an instrument in health care as the ratio of the increment of the social performance index of health care caused by the increment of the investment  $I_{HC}$  to a given level of health care investment  $I_{HC}$ . That is,

$$E_s = \left( \frac{\partial S}{\partial I_{HC}} \right)_{I_{HC}} \quad (8)$$



In general, the social efficiency of increases in health care costs decreases as these costs go higher [10], and it may eventually become negative [11].

### CONCLUSIONS

The methodological approach to planning regional development described above allows us to determine the role of the health care system in a region's general socioeconomic system, and to solve various organizational problems connected with the delivery of health care with due regard for exogenous factors. This model has been tested on data representing a hypothetical region (simulating a developing country case).

In the first version of our health care-oriented model, external subsystems are simulated by a modification of the WORLD 3 model [1], and the analysis of interregional relations follows along the lines of the GLOBE 6 model [4]. Health care delivery itself is described by equation (1).

Health care resources were grouped in the same way as investments were appropriated: professional medical education, management, equipment, medical science, disease prevention and medical education, and wages of personnel engaged in treatment and detection. However, the personnel engaged in treatment and detection was apportioned so that the number of sick who know about their disease but do not receive proper treatment is minimal when all resources are used.

Figure 1 shows prevalence dynamics in the four health care categories. Figure 2 shows the corresponding dynamics of health care resources divided among (1) disease prevention and popular medical education, (2) detection of the unaware sick, and (3) patient treatment using two different programs of allocation. Total investments are assumed to be increasing at 5 percent per year under a program (Program 1) that gives 2.5 percent of total investment to prevention and medical education. Figures 3 and 4 are similar diagrams, except that they include Program 2 in which 9 percent of total investment is given to prevention and medical education.

Figure 5 shows the index of social performance of health care  $S$  for the two programs.

Figure 6 presents the dynamics of the capital utilization factor  $M$  defined in equations 3 and 4. This figure shows that until time  $t_1$  (Program 1) or  $t_2$  (Program 2), the economic efficiency is zero. After time  $t_1$  the economic efficiency of Program 2 is better than that of Program 1.

The results from hypothetical data prove the validity of this approach to planning health care in a large region. It

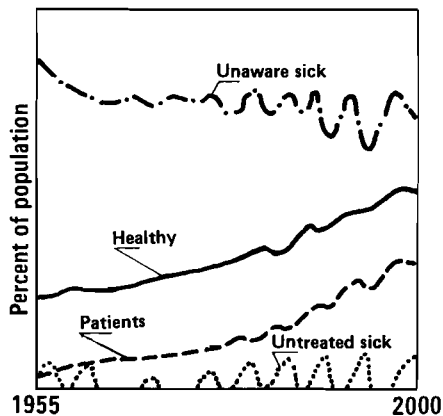

Figure 1. Health care program 1: prevalence dynamics in four health categories.

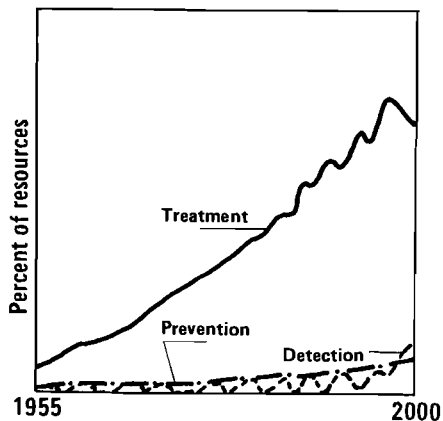

Figure 2. Health care program 1: health care resources distributed among three sectors (the sum of the three lines represents 5 percent growth per year on investments).

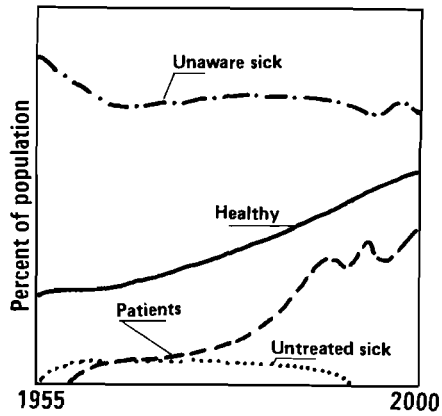

Figure 3. Health care program 2: prevalence dynamics in four health categories.

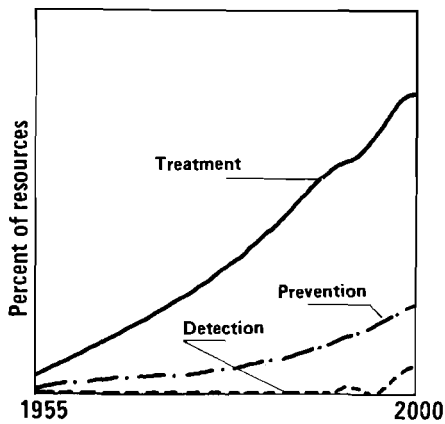

Figure 4. Health care program 2: health care resources distributed among three sectors (the sum of the three lines represents 5 percent growth per year on investments).

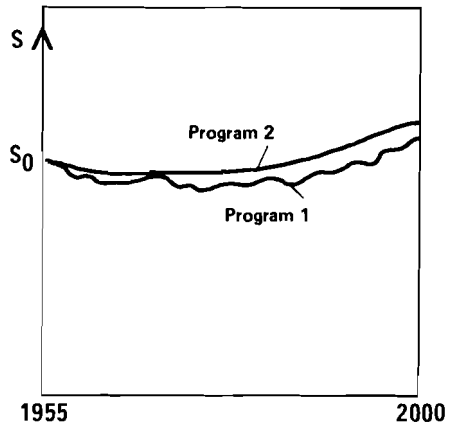

Figure 5. The index of social performance of health care for the two health programs.

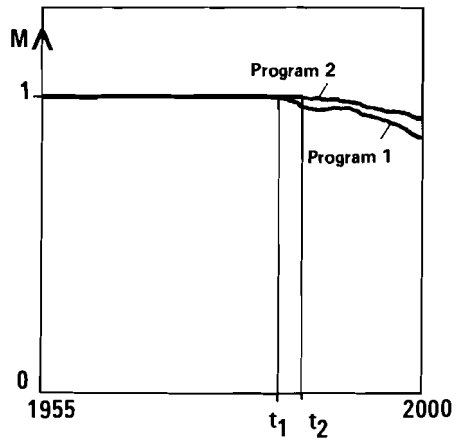

Figure 6. The dynamics of the capital utilization factor in the two health programs.

is clear that the preparation of actual data to run such a model will require considerable time because all the relevant data are not generally registered and, moreover, some data (e.g., about the latent morbidity and prevalence rate) cannot be acquired directly.

As well as developing the model both extensively and intensively, we are working on methods to determine parameters of the model. Several of such methods have already been developed at IIASA [12].

#### REFERENCES

- [1] Meadows, D.H., D.L. Meadows, J. Randers, and W.W. Behrens, *Dynamics of Growth in a Finite World*, Wright-Allen Press, Cambridge, Mass., 1974.
- [2] Bariloche Foundation, *Latin American World Model*, Preliminary Report presented at IIASA symposium, Baden, Austria, 1974.
- [3] Mesarovic, M., and E. Pestel (eds.), *Multilevel Computer Model of World Development System*, Vols. 1-6, CP-74-1, International Institute for Applied Systems Analysis, Laxenburg, Austria, 1974.
- [4] Burnet, R., and P. Dionne, *Globe 6: A Multiregional Interactive World Simulation Model*, *Simulation*, 20, 6 (1973), 192-197.
- [5] Venedictov, D.D., *Modeling of Health Care Systems*, in *IIASA Conference '76*, Vol. 2, International Institute for Applied Systems Analysis, Laxenburg, Austria, 1976.
- [6] Yashin, A.I., *Methodological Aspects of Modeling and Decision Making in the Health Care System*, in D.D. Venedictov, ed., *Health System Modeling and the Informational System for the Coordination of Research in Oncology*, CP-77-4, International Institute for Applied Systems Analysis, Laxenburg, Austria, 1977.
- [7] Olshansky, W., *A Basic Model of Health Care Systems*, internal paper, International Institute for Applied Systems Analysis, Laxenburg, Austria, 1976.
- [8] Klementiev, A., *Mathematical Approach to Developing a Simulation Model of a Health Care System*, RM-76-65, International Institute for Applied Systems Analysis, Laxenburg, Austria, 1976.
- [9] Kaihara, S., *A Simulation Model of Medical Demand in Japan*, in *2nd USA-Japan Computer Conference Proceedings*, Information Processing Society of Japan, 1975.

- [10] Rousseau, J.M., Toward a Global Equilibrium Model for Health Care System Planning, This volume, pp. 00-00.
- [11] Teeling-Smith, G., More Money into the Medical Sector: Is this the Answer?, *International Journal of Health Services*, 3, 3 (1973), 493-500.
- [12] Kaihara, S., et al., *An Approach to Building a Universal Health Care Model: Morbidity Model of Degenerative Diseases*, RM-77-06, International Institute for Applied Systems Analysis, Laxenburg, Austria, 1977.

## SYSTEMS MODELING AND HEALTH SERVICE PLANNING IN THE UK

A.G. McDonald

### INTRODUCTION

This paper is divided into three parts. The first part describes a number of systems modeling projects within the UK's Department of Health and Social Security (DHSS) and how these projects interact with policymaking within DHSS. The second part describes recent developments in the most far-reaching of our strategic modeling projects, the Balance of Care Study, which is the one most closely related to work at IIASA and which was first reported at the IIASA Biomedical Conference held in Moscow, December 8-12, 1975. The third part summarizes DHSS modeling of the progress of certain malignant diseases which, although not originally designed for service planning purposes, seems relevant to the IIASA approach as outlined in the earlier paper by Venedictov and Shigan.

### HEALTH CARE SYSTEM MODELS USED IN POLICYMAKING

In the UK, the Operational Research Service (ORS) are involved at all levels of the Department of Health and Social Security--the senior steering committee, the middle-management working groups and the teams directly concerned with analysis (e.g., the central analytical team) (see Figure 1). Thus the models developed by ORS are used in an iterative and interactive mode by policymakers and analysts at all levels. The results of analysis are not just simply presented in a take-it-or-leave-it manner. Indeed, the greatest value from mathematical models is derived from policymakers discussing the results of those models and examining the assumptions that lie behind them. Output of models need interpreting and in this way they learn something new about the main interactions within the system for which they are responsible. This knowledge may be of more use to them than the results of any individual run of the model.

The Balance of Care Study described later in this paper is only one, albeit the most ambitious, of several models developed by ORS for policy applications. This model, like the other models, is only appropriate for a certain range of policy questions--an "all-singing all-dancing" model cannot cope with all strategic issues. For example, in order to answer certain types of policy questions regarding health services manpower, one or the other of our manpower models rather than the Balance of Care Model should be used.

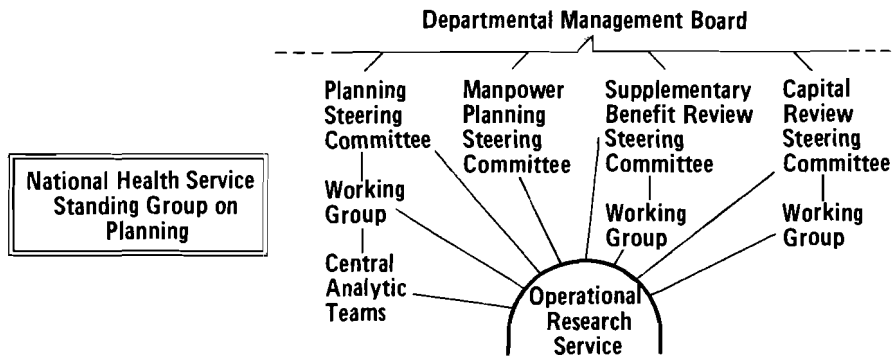

Figure 1. The interaction between ORS and all levels of the DHSS.

### Policy Studies

#### Resource Allocation Working Party

One of the main responsibilities of the DHSS is to allocate funds fixed in total amount by the Treasury, to the 14 Regional Health Authorities (RHAs) to cover each region's capital and revenue expenditures. At the instigation of the Ministers of DHSS, the Resource Allocation Working Party (RAWP) was formed to review the principles that determine the allocation of these funds. The aim was to produce a new allocation formula that would remove, in time, any inequalities in health care provision among the RHAs.

This formula was to be based on the health needs of the regions as reflected chiefly by their age/sex structure, adjusted for such factors as agency arrangements and interregional patient transfers. Regional age/sex structure, corrected for patient transfers, goes a long way in explaining variations in the use of health care resources. Nevertheless, usage continues to vary considerably, somewhat reflecting need but largely related to the availability of resources and how they have been used in the past.

RAWP was also required to modify the allocation formula in the light of any other factors, aside from age/sex structure, that contribute toward the health needs of regions. To this end, ORS, which has played an advisory role in RAWP and its associated subgroups, helped evaluate the implications of regional age/sex structures and other factors in terms of the financial target allocations for the regions.

There are, however, practical limits to the extent to which any region can sustain or justify increased or decreased funding in one year. ORS helped explore the implications of these limits, which were translated into different "ceilings" and "floors" on allocations.



Another problem ORS studies was that of patient transfers (i.e., patients receiving treatment outside the region in which they live). The cost of care for people who cross regional boundaries should be credited to the region in which they are treated. ORS used multiple regression techniques to estimate the average cost of treating various specialty groups. The estimates were then used to calculate a population correction for each region, and these corrections were incorporated in the allocation formula. ORS also proposed a method for incorporating population corrections representing long-stay psychiatric patients whose origin of residence could not be traced.

Finally, ORS programmed the 1976/77 allocation formula. This has enabled RAWP to study quickly and effectively the results of changing both the data used and the relative weightings of various features for the longer term.

The RAWP has now completed its work [1] and has presented its recommendations to the Ministers on methods of equitably distributing National Health Service (NHS) capital and revenue to the RHAs, Area Health Authorities (AHAs), and Districts, respectively. ORS is converting RAWP recommendations into suitable computer programs so that funds can be distributed efficiently in the future.

#### Implementation of the Mental Illness White Paper

The Mental Illness White Paper [2] was concerned with the policy of replacing the large mental hospitals (about 100) with district health and social service facilities. ORS developed a model that permitted estimating the costs to the public sector of implementing the White Paper policy over different time periods. The effects on annual capital and revenue costs of providing the proposed health and social services facilities at different rates were examined, that is, completing the social service facilities over a shorter, equal, or longer time than the health service facilities. Costs were assessed in terms of net present costs (which involves converting annually occurring costs to an equivalent capital sum using discounted cash flow methods, the equivalent capital sum then being added to the real capital cost), and in terms of the year-by-year actual cash flow. The model was constructed so as to explore the relationships between the rate of annual capital investment in the new district facilities and patterns of admission to mental hospitals. In addition, the effect of admission patterns on the length of time the mental hospitals remained in use and therefore the costs of operating them, including the cost of upgrading, were examined.

The model estimated that implementation of the White Paper policy over 30 years would have a net present cost 7 percent less (£200 million) than that of implementation over 15 years. An important result affecting decisionmaking was that different rates or patterns of capital investment had essentially similar patterns of revenue expenditure.

### Strategic Review of Mental Health Services in Dorset

ORS has been asked to help the Dorset AHA develop a comprehensive strategic plan for mental illness services in the area. This plan would involve adopting a 10 to 20 year planning horizon and will include closing sections of a large mental illness hospital and developing resources for the care of patients in the community and within the districts. Work will concentrate on the effect of such a plan on patients (in terms of new types of job, change of workplace, possible redundancies, and recruiting needs). ORS will also identify and attempt to quantify the implications of different strategies for the organization of mental illness services and for the present allocation of area resources. Further, it will develop, in conjunction with the area's revenue allocation working group, a basis for future resource allocation for mental illness services in the area.

### Review of Primary Health Care

Because of the importance DHSS attached to the development of primary health care, in June 1973, ORS commissioned Donald Hicks (who had been acting as a consultant in operations research to the Department for some six years) to review the literature on the subject. The result was a comprehensive work comprising 15 essays on various aspects of primary health care, including assessments of and quotations from some 400 books, papers, and reports. This work received much praise from within the Department, and toward the end of 1976, it was published by Her Majesty's Stationery Office [3]. First reviews, notably in *The Lancet*, have been enthusiastic, and the book seems likely to become a standard work on the subject.

### Planning Health Services

#### The Balance of Care Study

This study reviewed the Department's interdependent activities in Health and Personal Social Services (HPSS) and explored the consequences of different policies so that various policy options could be evaluated. Specifically, this meant examining what effect changing the balance of care both between and within hospital and community-based services would have on resources across the whole range of HPSS.

The main produce of the study was a macro model, which was used to investigate different patterns of health care within resource and financial constraints. The data for the model were obtained in a number of ways: from a search of the literature, from professional advice within the Department, and from collaboration with field researchers.

It must be emphasized that this model aims only to illustrate the consequences of policy decisions, not to make those decisions. The way in which the model explores options for patterns of care is described in the second section of this paper.

In view of the alteration in balance of care mentioned above, much attention was given to representation of choice, for each patient category, between hospital or other residential care and day or domiciliary care. Categories treated comprehensively in terms of number of patients to be treated (i.e., cover), modes, and standards were the mentally ill, the mentally handicapped, the elderly, the younger physically handicapped, maternity cases, and some types of gynecological and surgical cases. The remaining parts of HPSS are currently represented only at the aggregate level of the Department's Programme Budget. It is hoped to soon treat in greater detail patient categories for which significant care alternatives are believed to exist, for example, children and acute medical cases.

The macro model has been used several times to examine the consequences of policy decisions based on data from the Departmental planning System. Most recently, the model has been applied to analyses of successive drafts of Priorities for Health and Personal Social Services in England--A Consultative Document [4]. This has chiefly involved simulating planning proposals in order to estimate their consequences and exploring alternative strategies. The planning proposals have supplied information on the availability of resources and their allocation among patient groups, and assumptions have been deduced from the proposals about the numbers of patients to be treated. The macro model then shows the probable modes and standards of care that will result. In exploratory runs, the model has been given a limited amount of leeway to suggest alternative cost-effective sets of resources in order to show that improvements might be attained (e.g., higher standards, greater cover, lower costs).

To summarize, the macro model is intended to contribute to the Departmental Planning System by providing a means of testing alternative proposals and assumptions when these are expressed in terms of cover, modes, and standards of care. The response of the HPSS system to change in any part can be predicted, and hence proposals can be modified and retested freely. The model's flexibility makes it a useful planning tool; it is not intended as a device for producing a unique, "best" solution. The macro model differs from the Programme Budget in that it includes an analysis of different types of care suitable for various patient categories which is based on professional opinion and on the results of field research. The Programme Budget, on the other hand, starts from the existing situation and examines feasible developments from this in order to determine future priorities.

### Central Analysis of Regional Plans

The National Health Service Planning System is now operating in accordance with arrangements described in the working manual [5], and the first set of regional strategic plans was due to be submitted to the Department in January 1977. The Working Group on Planning (WGP) has been charged with devising appropriate procedures for DHSS processing of NHS planning submissions. A central analytical group, set up under the control of WGP, has undertaken numeric analysis of the NHS regional strategic plans. ORS, as a member of the central analytical group, and in conjunction with the working group, is considering what sort of analysis of plans is desirable and essential minimal contents of the first plans. Initial ideas are currently being discussed with various interested headquarters divisions, including professional colleagues.

### Guide to Service Planning

In order to carry out one of its roles, namely that of providing guidance to field authorities on service planning within the framework of the NHS Planning System, DHSS has established a multi-disciplinary working group called the Guide to Service Planning Group. ORS is represented in the group and particularly contributes advice on techniques for determining and evaluating planning options. ORS is also preparing a series of papers for the group defining the role of operations research in planning. These papers will be coordinated at a later stage into a form suitable for publication.

### Using the Macro Model for Joint Strategic Planning of Devon Health and Personal Social Services

The model is also being applied at a local level. Following a six-month pilot study, the Devon AHA and the Devon Social Services Department asked that the model be used to assist them in their joint planning activities, and this work is now underway. In this situation, the model will suggest various options for the best use of current resources and will generate joint strategic plans with the constraints of finance resource growth cuts, priority areas, and so on. This will allow production of a joint HPSS plan that will give the district health services the guidance that they need to modify services at the ground level.

Since the work in Devon started, other AHAs (e.g., Warwickshire) also wish to use the macro model, and work is starting as staff become available.

### Implementation of Plans at the District Level in Devon

The provision of health services at a local level must take into account local limits on capital and revenue allocations.

Operations research has helped the district administrators in the Torbay and Barnstaple health care districts to achieve this within the area strategic plan.

Operations research starts with the broad area guidelines and, based on these, searches for efficient options in the use of buildings and location of services within local revenue and capital constraints. This process will result in a detailed plan for the development of buildings and closure policies, together with manpower consequences at the district level, which will fulfill the main aims of the area strategic plan.

#### Future Provision of Health Care in the Wirral AHA

Upon the commissioning of a new District General Hospital of 935 beds at Arrowe Park, the health services in Wirral were likely to go grossly out of balance. The Wirral AHA would have almost twice as many acute but less than half as many nonacute beds as the average area. Furthermore, acute patients in that area were staying in the hospital for an average of 13 days compared with 10 days nationally. And the community health services were slightly under-provided.

Following a feasibility study, ORS suggested various strategies designed to correct these imbalances. Such strategies were not only designed to provide better services for those patients (particularly the elderly and the mentally ill) requiring community and nonacute health services, but would maintain the existing level of acute treatment per head of population. The latter could only be achieved with rational resource management.

A number of problems associated with achieving the desired pattern of services were identified and a program of studies embracing management problems was drawn up. This covered such problems as establishing an area-based management information system, admission and discharge policy system, workload scheduling of ancillary units, and so forth. These studies may form the basis of a longer term operations research project for the area.

Since completion of this feasibility study, requests have been received for further help of this nature from the Hampshire and Liverpool AHAs.

#### Health Care in the Calderdale AHA

The Yorkshire RHA asked for a study of health care in Calderdale AHA with special reference to the Upper Calder Valley, a rural community of about 30,000 people. Taking a five- to 10-year view, the feasibility study considered the broad options available, including the provision of a community hospital in the valley, and probable manpower and financial constraints.

The case for the community hospital could not be sustained. Consideration was given to the levels and disposition of both AHA and Local Authority (LA) resources for the main groups of patients (i.e., the elderly, the mentally ill), and these were compared with regional and national levels. The problem areas were highlighted and terms of reference and methodologies were suggested for several studies that might be undertaken.

This work led to a request for a study from both the area and local health authorities on the care of the elderly in Calderdale. This study, which is now underway, will suggest a framework for directing services to those most in need, will assess the implications of various options with respect to the balance between services, and will indicate possible options for easing the pressure on acute hospital services.

### Manpower Planning Studies

#### Manpower and Training in the Social Services

A working party was set up to investigate the training needs of the personal social service over a period of 10 years and, particularly, to consider the numbers of people who might study for the Certificate of Qualification in Social Work (CQSW) and the Certificate in Social Service (CSS). One of the problems anticipated was the bottlenecks, in manpower and training that might result from growth. The operations research was aimed at calculating the effects of five different growth patterns over 10 years, including a zero growth rate. This would enable the working party to compare the predicted numbers of social workers available with the anticipated numbers of qualified staff needed in the social services at the end of a 10-year span (1984 in the context of this report).

A simple computer program was written to calculate, for a given growth pattern in those enrolled in CQSW or CSS courses, the numbers of staff employed by the social services up to 1984. The calculations took into account different wastage and reentry rates in various parts of the service, those employed part time, and the flow of already qualified staff into teaching posts for the expanded courses. The effects of likely inaccuracies in the data and of ignoring the age dependence of the wastage were estimated and were found to be of little significance.

The collection of data for the model was a problem. While it was reasonably easy to determine the number of qualified staff working in various parts of the social services, it was very difficult to obtain information on wastage and reentry rates. Nevertheless, a fairly clear picture emerged and it was possible to predict, with a fair amount of confidence, the wastage rates among qualified workers up to 1984.

### Medical Manpower Planning (Medical Schools)

This study was aimed at enabling the Department to compare the numbers of doctors needed in the future with the numbers that would be produced under various conditions.

A manpower model was developed to predict, over a period of 50 years, the effects of reducing or increasing the rates of building new medical schools on numbers of doctors. The study also established the sensitivity of the estimates to the migration of British-born and foreign doctors, childbirth among female doctors, proportion of males to females in new medical school enrollments, and average retirement age and wastage in medical schools. The important factors proved to be migration of British-born and foreign doctors and childbirth among female doctors.

### Nurse Manpower Planning

This project was aimed at constructing models that would represent the changes in both existing numbers and flows of nurses and would project these numbers into the future, taking into account both trainee and qualified nurses. The calculations were performed under various assumptions concerning intake, wastage, and required numbers of nurses, with the nurses classified as follows: (1) trainee or qualified, (2) qualification (actual or intended), and (3) specialty.

### Efficient Use of Resources

#### Prescribing by General Practitioners

This study was directed toward discovering possible reasons for variations in prescribing costs, in terms of the cost per patient and the cost per prescription, in order to assist the Department's monitoring of prescribing expenditures. The work followed a pilot study undertaken in 1974. This study investigated relationships among such factors as the age/sex distribution of patients and the GP's list size and mortality of patients for the total prescribing expenditure of the Executive Councils.

This study was recently updated for the Family Practitioner Committees. What effect a GP's attendance at postgraduate therapeutic courses had on the individual GP's prescribing costs was considered, along with an age/sex breakdown of the GP's lists.

Further, the monitoring procedure for GP prescribing was examined to determine whether the cost per prescription would be a more useful monitoring criterion than the currently used cost per patient. First indications were that the new criterion was potentially useful, and this is being examined further.

### Hospital Bed Usage in the Cornwall AHA

This project resulted from a request from the Cornwall Hospital Management Committee for operations research help with the problems of patient overloads at Truro's two central hospitals. For example, bottlenecks were occurring at operating theaters owing to overburdening of theater staff. Initially, ORS concentrated on suggesting possible reallocation of patients to peripheral hospitals and on relocation of specialties within the Cornwall AHA's hospitals. These studies led to the consideration of communication between the central and peripheral hospitals, and for a trial period of six months an information room was set up at Treliske to act as a bed bureau. The information room worked successfully and relieved pressure at the center.

It was held that further progress could be made only if an information and intelligence system were introduced to improve the ways in which medical nursing staff use hospital resources. This view resulted from examining the requirements of any admissions policy for the central hospitals. Thus a system was developed for collecting information on patient flows (from AHA returns) and on resource usage (from hospital data), and a monthly analysis of this information helped relieve bottlenecks.

The hypotheses constructed in the ensuing discussion for exploring relationships among different aspects of the overloading problem have already led to significant changes in the organization. The Cornwall AHA now feels that its resources are being better used, which suggests that the methods used in Cornwall may be applicable more generally.

### Hospital Stores: Stock Control

It is estimated that the National Health Service holds about £45 million in total stocks at any one time, about one-third of which is in hospital stores. This project was aimed at devising a simple stock control system so that stores could give more reliable and economic service. The problem was one of cost-effectiveness to achieve specified levels of service at minimal cost.

The standard approach to this problem, based on calculating stock reorder levels and order quantities, was used, but to have applied it as often as it should be on each item stored would have involved considerable effort both mathematically and in the collection of data. Further, the cost of the labor involved probably would have outweighed any savings achieved in hospital stores, where most items are relatively inexpensive. Consequently, most of the research concentrated on developing ideal reorder levels and order quantities, in order to devise simple rules for dealing with stock control. It was important to test the sensitivities of the reorder levels and order quantities to approximations in data and in the form of calculation. Eventually, a set



of rules was selected by comparing its results with those of detailed computer calculations. A rule of thumb was also devised to take into account bulk purchase discounts.

The resulting stock control system was tested at one store in each region. Initial monitoring showed that the system might achieve a revenue savings of the order of £750,000 per annum and a reduction of £3 million in capital commitment. The initial implementation saved about £50,000 per annum (about 5 percent of the potential).

The extent and effectiveness of use of the system is presently not known, but a number of the new area stores are using it and the current savings is probably between £100,000 and £200,000 per annum. Detailed assessment of the system's performance was undertaken at two stores in 1976: savings were less than expected in one case, but matched earlier observations in the other.

#### Hospital Stores: Centralization

This study, again a cost-effectiveness problem, was aimed at determining what degree of centralization of hospital stores would achieve the required service at the lowest cost. An initial study suggested that centralization of stores, together with implementation of the stock control system described in the previous section, is usually the most economic policy. The operations research approach was to make a straight cost comparison of different degrees of centralization in an area. Five degrees of centralization were considered, ranging from no centralization at all to a single area store, and the capital and revenue costs of these options were calculated. In addition, since centralization of stores has advantages and disadvantages for both need and supplies management, the effect of centralization on these features were observed.

The relationship between storage and some cost elements was investigated by means of curve fitting; other more general relationships were studied on the computer. After the first centralized stores are set up and running normally, a comparison of their performance with that predicted by the operations research model will be used to monitor the model. It should be possible for the systematic cost comparison method that will result from the operations research study to be implemented by the regional management services staff themselves, with limited guidance.

By March 1976, 18 stores serving whole areas or units of similar size had been established, probably accounting for about one-fifth of the stocks of general supplies in the UK. Many other projects are in various stages of development.

### Hospital Laundries: Distribution and Storage of Clean Linen

An examination of alternative strategies for handling and storing finished work in hospital laundries concluded that the use of high-level racking and forklift trucks is not worthwhile economically. Other means of reducing the storage area are to be examined.

Data gathered for the study also indicated that a policy of common usage of linen--provided it was adopted by all customers of a given laundry--could reduce stockholding and sorting costs and facilitate the introduction of "fixed issue" or "daily quota" systems for the return of clean linen to hospitals which should yield further economies. The study also indicated that the building of extremely large laundries (capable of dealing with more than 250,000 pieces per week) may not result in economies of scale since at these sizes the management problems increase. The effect on distribution costs is to be examined, as are alternative forms of transport.

It is anticipated that the Advisory Committee on Laundries will ask for an extension of the study to cover alternative methods of handling and sorting soiled linen.

### The Organization of Ambulance Services with Metropolitan Counties

This study was carried out in 1971-72 in anticipation of the reorganization of the NHS. The aim was to work out how best to organize the ambulance services in those parts of the country that corresponded to the proposed Metropolitan Counties. More specifically, if one unified ambulance service appeared to be preferable, how should such a service be organized given existing resources? In addition, there was the question of how to divide costs among the constituent AHAs according to their demand on the ambulance service.

The initial study was based on the proposed West Midlands Metropolitan County and a method was developed for estimating the potential benefits of merging the seven existing ambulance services into a Metropolitan Service. Detailed cost and performance figures were not available, and so it was not possible to predict with great precision the savings that would accrue from such a merger. However, economies of scale were identified. It was demonstrated that in a typical Metropolitan Service revenue savings of about 15 to 35 percent (£250,000 to £600,000 per annum) of the total costs could be made. These savings chiefly result from better use of hitherto underused resources. The savings that would arise from the amalgamation of cross-boundary traffic, although appreciable, played only a minor role in the calculations.

Before NHS reorganization, there were no nationally accepted standards for an ambulance service, and so the service standards

provided by Birmingham (which were better than those of other existing services in the proposed Metropolitan County) were assumed for the whole West Midlands Metropolitan Service. The feeling was that service to patients would improve as a result of implementing the findings of the study. The study was subsequently extended to cover other proposed Metropolitan Services and further revenue savings were demonstrated (e.g., Greater Manchester about £400,000 per annum, Merseyside £170,000 per annum, South Yorkshire £180,000 per annum).

#### Performance Standards and Measurements in the Ambulance Service

With the reorganization of the NHS, the responsibility for ambulance services was to be transferred from the local to the area health authorities, and the Department recognized the opportunity this offered to define standards for ambulance services. The objective was better service for patients (other than medical or quasi-medical service), using existing resources, than had resulted from the Local Authorities' independent targets.

An operations research study was undertaken to define levels of service and to recommend appropriate standards of achievement. The management principles necessary to maintain the proposed standards of service were investigated as was the relationship between resources and the level of service to patients.

This was the first time in which criteria relating to patient service were developed to replace cost criteria in planning and monitoring the ambulance service. The demands placed on the service by various categories of patients were analyzed and on the basis of the results, measures of performance were recommended for the main patient categories, i.e., emergency, urgent, and nonemergency. The performance of the ambulance service was monitored to show ambulance managers where efforts should be concentrated to improve patient service. Standard or target levels of service had to be adopted before performance could be measured. As there were great differences in the operational characteristics and resource capabilities of the proposed Metropolitan and Area Services, one set of standards was recommended for each.

Field trials were conducted in order to establish a practical system of monitoring. The 12 ambulance services selected for the trials were grouped geographically according to the proposed re-organized services. The field trials were designed to investigate practical methods of monitoring performance against defined standards in such a way as to not disrupt the normal running of the Area ambulance services, and to avoid introducing an excessive clerical workload.

The new standards have provided the AHAs a means of assessing future changes in the system. Ambulance studies based on the standards are being undertaken to improve the services in some of the AHAs. Some 20 studies of emergency cover have now been completed for rural, urban, and metropolitan services.

### Artificial Limb-fitting Service

The development of Modular Assembly Protheses (MAPs) presented various problems for the artificial limb-fitting service (for example, times of repair and delivery of MAPs are affected by the extent to which MAP assembly facilities are decentralized). The Disablement Services Branch (DSB) felt that if problems of this nature were solved, the MAP proportion of new lower limb issues (15 percent) could be increased. Thus DSB commissioned ORS to study how the following would affect costs and standards of service: (1) introducing a new modular leg system in addition to the one already available, and (2) varying the extent of contractor representation at centers.

Five different options for combining the modular leg systems were treated including not accepting the new system, abandoning the old system, and implementing both systems subject to various intercompatibility requirements. The cost of each option and the level of service it would provide were analyzed subject to different sets of conditions. These conditions covered such features as degree of centralization of facilities and level of technical advance in the development of modular limbs. The results of the study showed that under certain options a 10 to 15 percent improvement in the level of service to amputees can be achieved with only an insignificant increase in cost. The relative attractiveness of the different options remained the same under each set of conditions.

Four systems of contractor representation, which correspond to different degrees of rationalization, were investigated. The study showed that there are insignificant cost advantages and service penalties in undertaking any extensive rationalization program with respect to contractor representation.

### Management of 120-Bed Clinical Nursing Units, Wessex

From 1970 to 1974, a large research program, funded by the Department, was carried out in Wessex. It studied the management of 120-bed clinical nursing units in preparation for a move into the new units at Southampton and Basingstoke in 1973. This program covered many topics, including:

- the pooling of beds between consultants,
- progressive patient care,
- nursing workload measurement,
- patient/nurse dependency,
- the introduction of information rooms,
- staff and patient attitude surveys,

- role analysis (nursing officers),
- some cost studies.

Operations research played a major role in developing a management game to explore the effects of pooling, progressive patient care, and admission/discharge policies for several specialties, including general medical, general surgery, and orthopedics, and for exploring the management of mixed specialty units (floors). It also played an integral part in the development of admission/discharge policies and in setting up the information rooms. Much of the work was incorporated into daily management practices as the research proceeded and the value of the information rooms was amply demonstrated in the smooth transfer of patients from the old wards at Southampton General Hospital into the new 120-bed units during 1973/74. The cost studies highlighted the difficulty of accurate ward costing and did not detect any appreciable change in running costs in moving from the old wards to the new "race-track" 120-bed units. The whole four-year program of work has been described in a recent book [6].

#### Alternative District Arrangements

This study was requested by a London AHA in which there are four health districts serving three local authorities. Some care is also received from and provided to neighboring health authorities.

The purpose of the study was to evaluate how different district arrangements would affect patient care, the cost of delivering care, and administrative problems associated with the planning and delivery of care within both the health and local government authorities. The repercussions for the teaching and research responsibilities of the AHA were also assessed.

It was shown that for the same levels of patient care, different district arrangements would affect the cost of service delivered to patients and the convenience with which they could use some aspects of the service. On balance, it showed that there was no advantage in changing the present arrangement of health districts.

#### Building Studies

##### The Size of District General Hospitals

The aim of this study was to explore, for District General Hospitals (DGHs), the relationships between size and cost and non-cost features of hospital building. A series of models was constructed to show the financial consequences--i.e., capital, revenue and accessibility costs--of building DGSs of various sizes for different demographic locations. Four such locations

were chosen to correspond to rural, urban, and two intermediate densities of population, defined in terms of the population figures of typical health districts. Two different types of services were considered: (1) providing all beds in a DGH, and (2) allocating about 35 percent of the beds (mainly the nonacute) to peripheral (community) hospitals. A computer calculation gave the costs of these various options.

Total cost curves were drawn to summarize the results for each case. Each curve gave an economic size range (ESR) of DGH sizes (in terms of number of beds) for which the total cost was within 1 percent of the minimum. For the service in which all beds were provided in DGHs, the ESRs were:

<u>Type of area</u>	<u>Number of beds</u>
Rural	780-1300
Intermediate (1)	800-1300
Intermediate (2)	800-1300
Urban	810-1300

If community hospitals accounted for 35 percent of the beds, the ESRs were:

Rural	500-880
Intermediate (1)	500-880
Intermediate (2)	580-900
Urban	640-920

These figures show that provision of beds in community hospitals substantially reduces the ESR in all cases.

The computer calculation also explored the sensitivities of the costs to such factors as building times, discount rates, land purchasing policies, and phasing of buildings. (Building times and phasing prompted separate studies, described in the next section.) Robust ranges (RRs) of hospital size were obtained; these ranges contain all hospitals that cost within 1 percent of the minimum cost when the sensitivity tests are applied. If all beds were provided in DGHs, the urban and rural RRs were 1100-1200 and 790-1220, respectively. If 35 percent of the beds were in community hospitals, the urban and rural RRs were 690-890 and 540-760, respectively.

Studies of noncost features such as medical opinion on size of specialty, number of consultants per specialty, minimum number of specialties per hospital, staff and patient attitudes toward

hospital size, and the effect of size on internal communications were also carried out. On the whole, the RRs were still acceptable in the light of these factors. The questions of specialty size and number of specialties resulted in larger DGHS being suggested, but some compromise on these issues seemed to be possible.

#### The Phasing of District General Hospitals

This study was undertaken to determine the sizes of the phases in which DGHS should be built. The chief features examined were cost of land and bed usage (number of new beds times length of time for which they have been available). A model was developed for relating these features to time of building for different phasing policies.

Maximum usage was obtained if the phases were made as small as possible, as such phases take less time to build. On the other hand, small phase sizes make building more costly. A contributing factor for both capital costs and revenue costs was overprovision of facilities for later phases when the first phase is built. However, small phases needed to be 15 to 20 percent more expensive than a large one to offset the advantage of maximum usage. As a result of the phasing study, the regions were advised to build DGHS in as small units as were medically and operationally viable.

#### Time and Cost Overruns of Hospital Building Schemes

This study was based on hospitals that cost over £15 million. Information was needed on the extent to which, and reasons for which, hospital building schemes exceeded initial allowances of building time and money. Such data were neither readily available nor very reliable. However, enough data existed to test statistically the effects of starting times, management reporting systems, types of site, size of contract, and number of variations made by the architect on building time and cost overruns.

From the results, it appeared that the frequency and efficiency of reporting to managers was one of the chief features in minimizing time and cost overruns. Hence management information systems must be examined carefully with a view to improving them.

#### Upgrading Hospital Stock

The Hospital Building Division of the DHSS asked for help in determining whether or not it would be practical for the Department to provide guidance on the economics of upgrading. Because of the limited resources available to ORS, the detailed study of actual schemes was restricted to nursing sections only.

It was shown that nursing sections of old hospitals could be upgraded to a standard equivalent to that obtained in a new hospital, and often at a cost less than that of a new building. However, to achieve these standards and maintain a nursing section of sufficient size to use nursing and other staff economically, some extension of the section is often required. This upgrading may only be a practical alternative to building new for those hospitals in which the existing layout leaves room for the necessary extensions. The study also indicated some ways in which the Department could give additional guidance to the health authorities.

THE BALANCE OF CARE STUDY

The ORS Balance of Care Model, which was reported in detail at the March 1977 IIASA workshop and at the 1975 IIASA Biomedical Conference in Moscow, is shown in Figure 2.

This model represents a pattern of care delivery in terms of three main groups of variables. The first is cover, or the numbers of patients who actually receive treatment from the health services. These numbers are broken down into client groups, which in turn are further broken down into categories. The client groups

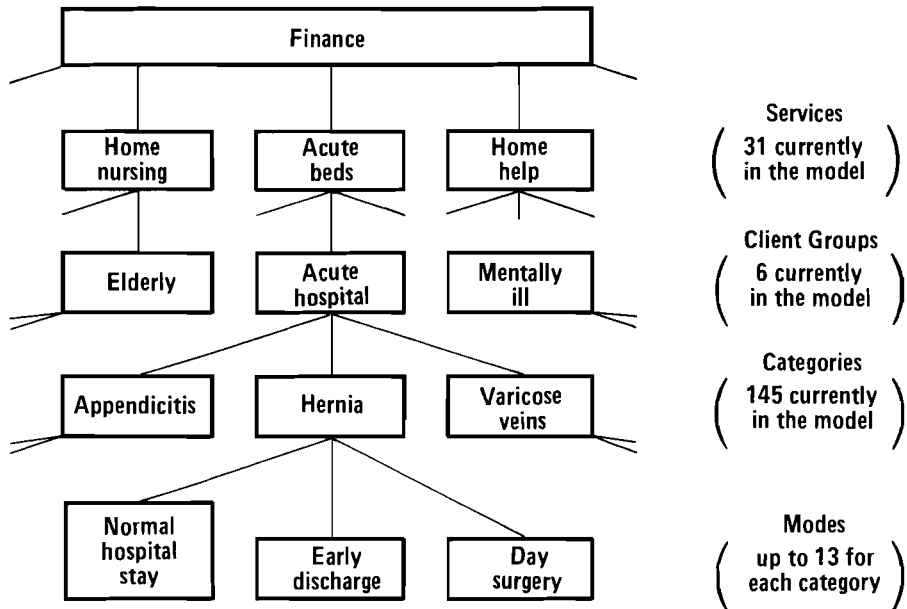

Figure 2. Structure of the Balance of Care Model.



correspond to different parts of the DHSS policymaking organization; for example, the elderly client group is concerned with services for the elderly population other than those who are acutely ill.

The second main group of variables is modes, which describe the alternative forms of treatment or care that might be available to a patient. For example, in the case of hernia repair one mode of treatment consists of a stay in an acute hospital including surgery, whereas an alternative mode consists of day surgery followed by nursing in the patient's own home, without an overnight stay in the hospital.

The third main group of variables is standards. Here we are concerned with the standard as perceived by the patient; for example, in the case of the hernia patient in the day surgery mode the relevant standard would be the number of home nurse visits received.

Figure 3 further describes modes and standards for one particular category within the elderly client group. Apart from the institutional modes of care (in hospital or in a residential home) there is also a domiciliary mode of care. This figure presents a simplified version of the model representation. In the full model representation, there is a wide variety of domiciliary modes of care to represent the variety that can occur in real life.

The first version of this model was formulated in terms of a linear program to minimize cost for fixed cover and standards. Since then, the model has developed considerably. In the version we are now using, cover, standards, and modes are treated as variables and the objective function consists of a utility function (termed Inferred Worth), which is maximized. A mathematical description of this formulation is given in McDonald, Cuddeford, and Beale [7] and will not be repeated here. Instead, here is a review of some recent work ORS has done to calibrate the elasticity parameters that are involved in the Inferred Worth function.

This calibration work commenced with a literature review by O'Neil [8], who had discovered that the literature contained very little methodology relevant to the task confronting us. Accordingly, we then developed two of our own methods. For the first method, we first assembled data describing the actual allocation of health care resources in a past year. Second, using this data, we defined constraints on the model which described the allocation of resources among client groups in that year. Third, we ran the model under assumptions appropriate for that year and we observed the relative sizes of the shadow prices for those constraints that we obtained in the optimal solution. Fourth, we adjusted the elasticity parameters of the objective function in such a way as to tend to equalize these shadow prices. Fifth, using a specially constructed algorithm, we repeated the third and fourth stages iteratively until the relevant shadow prices

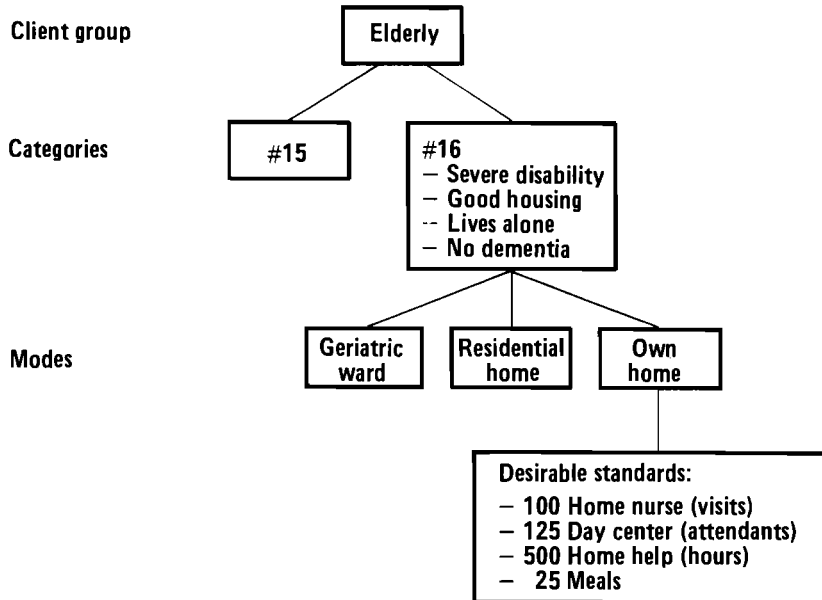

Figure 3. An example of modes and standards from the elderly client group.

were approximately equal. In this way, we hoped to achieve a set of elasticities that correctly enables the model to reproduce the past allocations. This method has been described in a paper by Sullivan [9].

Unfortunately, this method failed to converge in the required manner. This led us to develop a second method, which has been described by Coverdale and Negrine [10]. In this method the representation of the model is averaged within client groups in a certain manner. An analytic procedure is then used to calculate those elasticities that produce a precise fit of the model, so averaged, with empirical data. More success has been achieved with this second method, and the model now produces a satisfactory representation of resource allocation behavior in the National Health Service.

This model is now being used in an interactive and iterative manner with policymakers to explore various issues. The model is run and the results are discussed with policymakers who then request further runs and so on until a model solution is obtained that corresponds most closely with a desirable policy outcome.

The model is currently being applied in the county of Devon, which has a population of about 1 million. One of the special features of this application is that the model is being used to

assist in the joint planning of both health and personal social services in the county. Health and personal services are administered separately in the United Kingdom, which creates special problems in developing plans that are consistent between the two services.

Application of the model in Devon could particularly assist in this task. Figure 4 shows that the senior level of the planning function is carried out by a Joint Care Planning Team comprising senior officers from the health authority and from the County Social Services Department. Beneath them comes the Balance of Care Subgroup which comprises members of second line management in the two services and operations research scientists from ORS and from an institute at Exeter University in Devon with whom ORS is collaborating. This group is responsible for the analysis carried out with the model. They in turn can call upon the services of the care group local advisers who are leading professionals in Devon in various branches of the Health and Social Services. These advisers are responsible for supplying the detailed assumptions about patient care included in the model. It is worth noting, therefore, that a great deal of trouble has been taken to build into the model assumptions about treatment and care that are appropriate for Devon and that may differ in certain respects from the assumptions we are making at the national level.

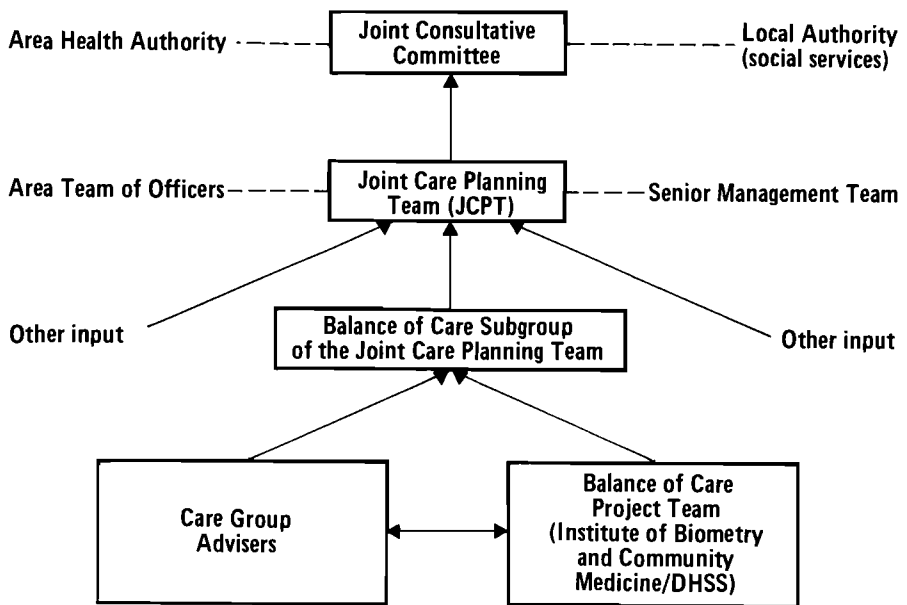

Figure 4. Organization of the Devon project.

Joint planning of Health and Personal Social Services is relatively new in the UK and the managers of these services have been eager to use the model. It seems that there is no other planning device that puts both services into the same frame of reference, and the model has and is being used successfully for the production of joint plans. Some of this work is described by Convin and Walker [11].

#### MODELING THE PROGRESS OF MALIGNANT DISEASE

One of the problems faced by physicians who are experimenting with alternative cancer treatment regimes is the long time required for enough patients to pass through each regime before the relative efficacy of the different regimes can be assessed by conventional statistical methods. Accordingly, we have constructed a mathematical model of the progress of patients suffering from certain cancers which we are using to assist in the evaluation of clinical trials in a number of hospitals in the UK and in the USA. Some of this work is described by Whitehouse, Jackson, and Aspdeh [12].

The models were not built with the intention of being applied to Health Service Planning. However, it seems that this work is relevant to the IIASA modeling schema described in the earlier paper by Venedictov and Shigan, and in particular to the disease prevalence submodel they describe. Thus our cancer model will not be described in detail but your attention merely drawn to the reference mentioned above.

#### REFERENCES

- [1] Resource Allocation Working Party, *Sharing Resources for Health in England*, RAWP Report, Her Majesty's Stationery Office, London, 1976.
- [2] Department of Health and Social Security, *Better Services for the Mentally Ill* (Cmd G233), Her Majesty's Stationery Office, London, 1975.
- [3] Hicks, D., *Primary Health Care--A Review*, Her Majesty's Stationery Office, London, 1976.
- [4] Department of Health and Social Security, *Priorities for Health and Personal Social Services in England--A Consultative Document*, Her Majesty's Stationery Office, London, 1976.
- [5] Department of Health and Social Security, *The National Health Service Planning System*, Her Majesty's Stationery Office, London, 1976.
- [6] Hicks, D., *The Management of 120-Bed Clinical Nursing Units* (to be published).

- [7] McDonald, A.G., G.C. Cuddeford, and E.M.L. Beale, Balance of Care: Some Mathematical Models of the National Health Service, *British Medical Bulletin*, 30, 3 (1974), 262-270.
- [8] O'Neill, J.M., *Parameter Estimation for the Balance of Care Model*, Unpublished Warwick University MSc Thesis, 1976.
- [9] Beale, E.M.L., and J. Sullivan, *Mathematical and Computational Concepts of a Macro Economic Model of the Balance of Health Care*, Proceedings of NATO Conference on Systems Science in Health Care, 1976.
- [10] Coverdale, I.L., and S.M. Negrine, *The Balance of Care Project: Modelling the Allocation of Health and Personal Social Services* (to be published).
- [11] Convin, R.W., and C.L. Walker, *A Model to Support the Planning of the Provision of Health and Personal Social Services Resources: A Case Study*, Paper presented at Paper Fair of Euro 11, Stockholm, 1976.
- [12] Whitehouse, J.M.A., R.R.P. Jackson, and P. Aspdeh, *A Systems Approach to the Evaluation of Clinical Trials in a Specialist Oncology Centre*, Proceedings of NATO Conference on Systems Science in Health Care, 1976.

ANALYZING DEMANDS FOR MEDICAL CARE BY COMPUTER SIMULATION:  
AN EXAMPLE OF APPLICATION OF A HEALTH CARE SYSTEMS MODEL

S. Kaihara

PRIMARY COMPONENTS OF HEALTH CARE DEMANDS

The present difficulty in interpreting health statistics may stem from the fact that they result from the interactions of many factors. For example, the number of patients is influenced by the structure of the population, the incidence rate of diseases, the attitude of consumers toward seeking medical care, and so on. Accordingly, it is very difficult to predict if an increase in patients one year will continue in the following year.

Based on these considerations, a group at IIASA has proposed an approach to analysis in which statistical data are transformed into more essential factors. By "essential factors" we mean (1) that the factors are directly related to the health care system, and (2) that secondary effects on these factors are identified. The factors identified were: population structure, morbidity rate, recovery rate, death rate, patient registration rate, and awareness rate [1]. With the use of statistical data from Japan, we applied this concept to an analysis and projection of future medical demands in that country.

CONCEPT OF A MODEL

The factors identified were formulated as a simulation model. In this model, total population was divided into four groups: (1) the healthy, (2) the unaware sick, (3) the sick without medical care, and (4) patients. Of course, many factors would influence the flows between these four groups. For example, various incidences of illnesses would affect the flow between the healthy and the unaware sick. Advances in standard of living and education would affect the flow between the unaware sick and the sick without medical care, for the more people are educated medically, the more they pay heed to their illnesses (i.e., our awareness rate factor). The sick without medical care flow more into the sick with medical care category when they can obtain medical care more easily (i.e., our patient registration rate factor). And, of course, the rate of medical diagnosis and treatment will affect the return rate from the patient category to the healthy category (i.e., our recovery rate factor). Using these factors, we intended to attribute the change of medical demands to the changes of flows between these groups.

DATA AND CALCULATION

The concept of the model described in the previous section was tested using the Japanese health statistics data at national level. Figure 1 shows the structure of the simulation model used for calculating the Japanese data except for some supplementary flows and differentiation among age groups. The supplementary flows were assumed to make the calculation more reasonable. X1, X2, X3, and X4 represent the healthy, the unaware sick, the sick without medical care, and the patients, respectively. R2, R3, R4, and R6 represent morbidity rate, awareness rate, patient registration rate and recovery rate, respectively. The inverse flow from X2 to X1 (R9) means the sick who get well without consulting physicians. In this model, each group is also divided into four age levels; 14 and under, 15 to 44, 45 to 64, and over 65. R7 and R8 represent the flows between these age groups. Thus the model is made up of 16 different groups, with 29 flows among them. The model is then expressed by a set of differential equations. If the rates are assumed to be constant over a year, and if the system is in equilibrium in that any large changes due to external cause do not take place, this equation can be transformed with a set of first order equations.

To calculate the model, the following statistical values were used as direct input: birth rate for R1 and population data for R7 and R8. The rate of selecting medical care, published in the "National Health Survey" was used for calculating R10. The "Patient Survey" was used for calculating X4 and prevalence rate in the "National Health Survey" for calculating X3.

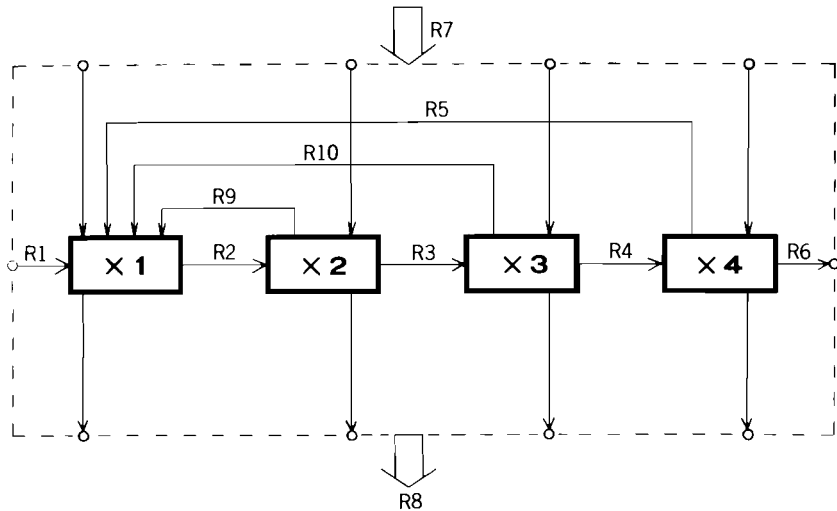

Figure 1. Structure of the simulation model used for calculating the Japanese data.

Patient registration rate (R4) was estimated from the number of first visits to physicians in the "Patient Survey", with some adjustment in the process of simulation. Recovery rate (R5) was estimated from the data on "Duration of Illness" in the "National Health Survey", using the fact that recovery rate is related to the inverse of duration of illness.

No statistical values are presently available for morbidity rate (R2), awareness rate (R3), or R9 (unconscious recovery from illnesses). Since X1 (the number of healthy) and X2 (number of unaware sick) are not known, it is not possible to calculate the morbidity or awareness rate from these data, either. However, if one of above values is given, the other parameters can be calculated from the sets of equations.

In this study, the morbidity rate (R2) was assumed to be constant for the past 15 years, and other parameters were calculated on this assumption. This assumption may not be justified in some other countries, but in Japan considering standard of living, sanitary conditions, and nutrition, it is unlikely that the morbidity rate has changed in the past 15 years. The calculation was performed for each year, assuming that the system was in equilibrium within that year. After all parameters were obtained for each year, the total model was run for the past 15 years, using the program DYNAMO.

#### RESULTS OF CALCULATION

Figure 2 shows the calculated results of essential factors for Japan. Note that the awareness rate gradually increased from 1960 to 1975, which seems to be the chief cause of the increase in the prevalence rate and total number of patients. The gradual decrease in the recovery rate also may have contributed to the increase in patients. The Patient registration rate gradually increased until the mid 1960s and then decreased again, which might have been caused by the relative shortage of medical supplies.

#### Further Analysis

We used the results of our calculation to further analyze the reasons for the increased number of patients in the past in Japan (see Figure 3). It is well known in Japan that the number of patients increased very rapidly, but it has never been clearly established which factors contributed most to this increase. The model was first run on the assumption that only the population structure had changed. Then one parameter, namely the change in the awareness rate (CR3) was added, followed by another parameter, recovery rate (CR5). The solid line shows the result when both parameter changes were included. It is interesting to note that the change in population structure did not contribute significantly to the increase in medical demands in the past years.



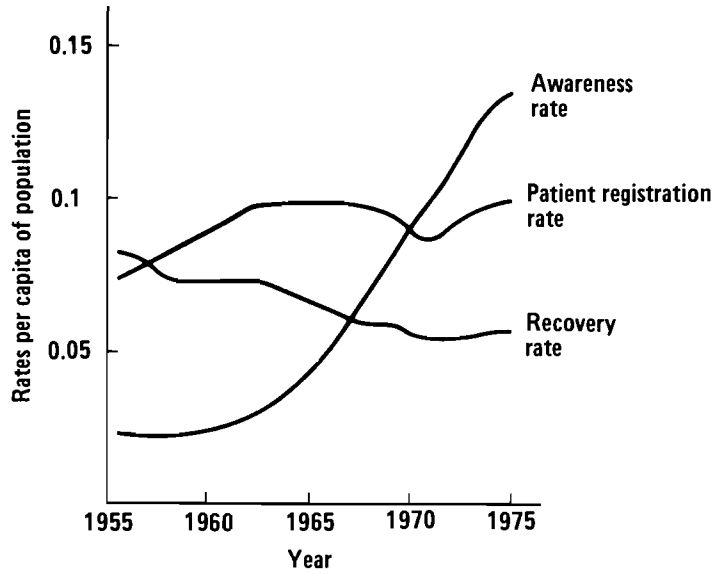

Figure 2. Calculated results of essential factors for Japan, 1955-1975.

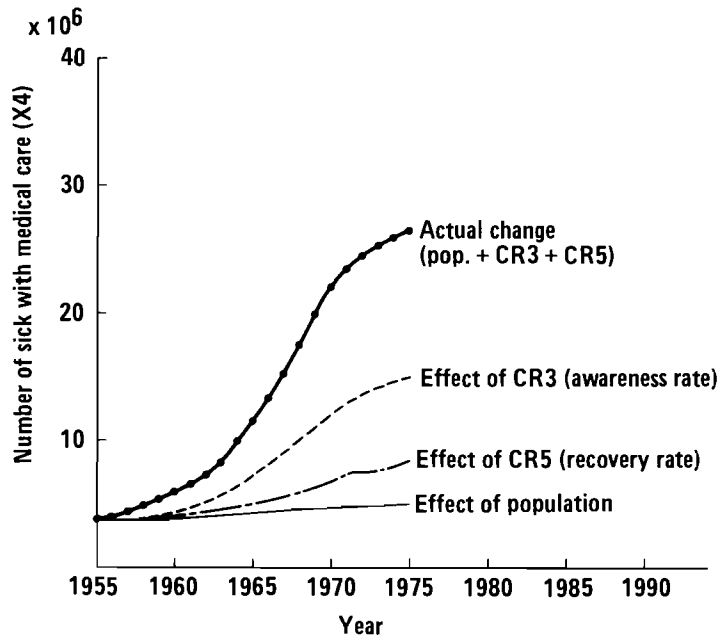

Figure 3. Effects of various factors on the annual change in the number of patients.

On the contrary, the change in the awareness rate (CR3) was most remarkable, and this was considered to be the main factor behind the increased number of patients. This result can be summarized as follows: The past increase in the number of patients was caused chiefly by an increase in the awareness rate, that is, the rate at which the unaware sick get to know their illnesses.

#### Estimating Future Trends in Numbers

On the basis of this model, future trends in the number of patients were estimated (Figure 4). The factors that influence demands for medical care were included one by one. Figure 4 shows that there are now marked differences to past trends, namely that changes in population structure will greatly affect the future increase in the number of patients, and that an increase in the awareness rate (CR3) will no longer be a strong factor (for further analysis, see [2]).

#### SUMMARY

A method of analyzing demands for medical care by computer simulator, based on a calculation of essential health care parameters, was applied to Japanese statistics at the national level. This method showed that over the past 15 years, the awareness factor was the most important factor contributing to an increase

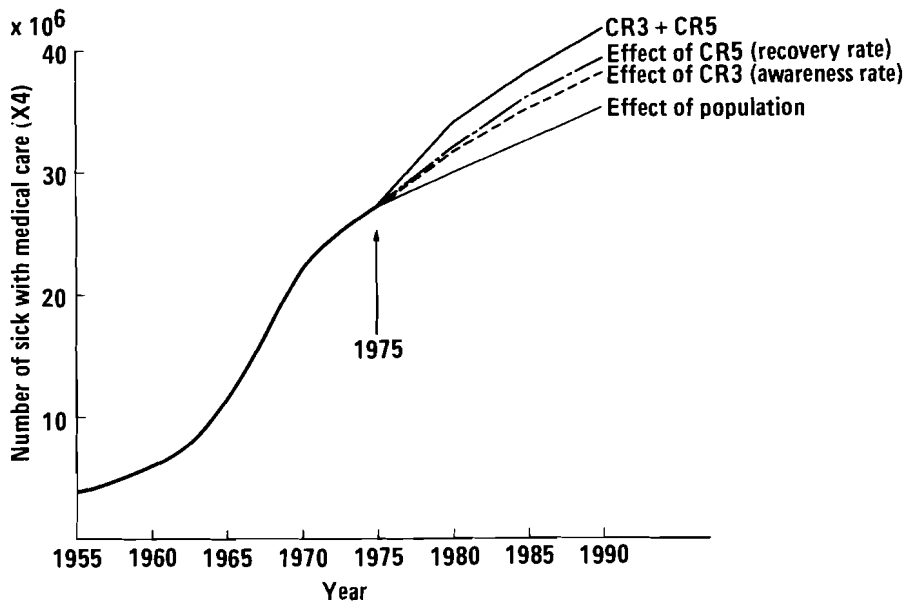

Figure 4. Estimated annual changes in the number of patients, to 1990.

in the number of patients. However, the model also showed that changes in the population structure will be the main cause of future increases in the number of patients.

REFERENCES

- [1] Kaihara, S., I. Fujimasa, K. Atsumi, and A. Klementiev, *An Approach to Building a Universal Health Care Model: Morbidity Model of Degenerative Diseases*, RM-77-6, International Institute for Applied Systems Analysis, Laxenburg, Austria, 1977.
- [2] Kaihara, S., N. Kawamura, K. Atsumi, and I. Fujimasa, *Analysis and Future Estimation of Medical Demands using a Health Care Simulation Model: A Case Study of Japan*, RM-78-3, International Institute for Applied Systems Analysis, Laxenburg, Austria, 1978.

TOWARD A GLOBAL EQUILIBRIUM MODEL  
FOR HEALTH CARE SYSTEMS PLANNING

J.-M. Rousseau

EQUILIBRIUM MODEL

The classical approach to planning any health care program generally proceeds as follows. First, planners evaluate the needs of the population in relation to the proposed program and then estimate the amount of resources required to satisfy those needs. An assessment of the plan in terms of health benefits to the population is generally done qualitatively and decisionmakers receive no help in evaluating the impact of allocating only a fraction of the required resources (because he or she cannot afford the total plan) to the proposed program. Moreover, this estimation of the resources needed is valid only under the assumption that the target population alone will have access to the program and will consume the resources only in the amount projected.

It is well known that this is not always the case. Generally, the entrance to any health care program is the physician's office, and physicians may not have the same perception as the planners because they are seeking the well-being of their patients, not of the system. Thus they will then perceive any health care program as a service available to the benefit of their patients whether or not their patients fall into the planners' target population. Moreover, a gap may also exist between the needs perceived by the planners and the needs perceived by the population. Because the administration of the health care system cannot control the utilization of the resources it provides, the classical planning approach may not be valid.

But, this kind of planning problem is not unique to the health care system. In transportation, for example, a route that was built on the basis of the actual behavior of the population that travels by car may soon have an unexpected congestion problem. People cannot be forced nor expected to select their travel plans in order to maximize the efficiency of the transportation network. It is essential that this fact be recognized in any planning effort.

Planners tend to set up models that prescribe how people *should* react in order to optimize the well-being of the system under study. What is needed is an approach in which one would try to model how people *would* react if a given service (e.g., health, transportation) were provided.

This has been achieved in transportation planning. Very accurate models have been built to evaluate the traffic flow in an urban network (for examples, see [1]). These models use data on the origins and destinations of the travel demand, assume that everybody seeks to travel at minimum time, and relate the time spent on a given arc to its capacity and level of flow. The system is said to be in equilibrium if no change of itinerary by one individual could result in decreased travel time for that person. These models are actually under generalization to include, for example, the choice that passengers might make between cars and the transit system [2] and to take into account the availability of parking spaces [3]. The end-product will be an urban transportation model that will show decisionmakers, with their priorities and objectives, how alternative policies might affect the transportation system. The model will be descriptive rather than prescriptive.

In the health field, McDonald, et al. [4] have developed a very successful model in this direction that is based on the premise that when resources are increased in a health program, both the number of patients and the average amount of resources consumed per patient are increased. This model is currently used by the planning unit of the British Health and Social Security Department. We have tested an equilibrium model by which we forecast the resulting medical practice given an amount of physician resources available by specialty, a number of medical procedures to be performed by category, and an hypothesis on the ideal way physicians want to practice medicine [5,6]. Satisfactory results were obtained with this model. In this paper, we describe a generalization of this approach or what in our view could be an equilibrium model for the health care system.

#### THE BASIC HYPOTHESES

We believe that in general any health care consumption generates a benefit in the eyes of the consumer. Mathematically, we say that there exists a monotone, increasing utility function with decreasing marginal returns relating the level of health care consumption and the perceived general well-being (including health states). By speaking of perceived general well-being, we wish to obviate Illich's point of view [7] which asserts that an increasing habit of health care consumption is not only a health hazard, but it creates a dependence on the medical care system that affects human dignity and liberty. These ideas, however true, are not politically feasible and will not be discussed here.

On the other hand, it is in the interest of a resource (e.g., physician, clinic, hospital, hospital department) to be utilized at acceptable capacity. This incentive is either monetary, as in the case of physicians paid for each procedure performed, or self-preservation, as in the case of a health organization that may lose funds and/or personnel if not satisfactorily utilized.

A direct corollary to these relations is that any increase in resources will generate an increase in consumption. Moreover, for all practical purposes we must assume that there is no saturation point for health care demand. Because any health care consumption is assumed to generate a benefit, it is clear that whenever this benefit is perceived as greater than the inconvenience to secure it, a resource is consumed. Because any addition to a resource increases its availability, the number of customers and/or the quantity of resources consumed per person increase.

These facts can be verified at a general level. We have reported [6] that we found a direct linear relationship between the density of physicians in a district and the average amount of medical procedures performed per resident. In fact, the average income of physicians (directly related in our case to their quantity of work) is essentially the same whatever the density of full-time physicians in a district.

In conclusion, there is in the health care system an equilibrium between resources offered and resources consumed. This equilibrium is influenced both by resources provided (e.g., by physicians with different ways of treating illness) and by the resources needed (e.g., as objectively or subjectively perceived by the population). Some health care consumption is incompressible (e.g., childbirth, broken bones) and receives high priority treatment. Other kinds of consumption are influenced directly by the availability of services (e.g., treatment for a cold, tiredness). We tried to model this equilibrium in order to help planners assess the consequences of adding or reducing resources when establishing programs.

#### A GLOBAL HEALTH CARE FLOW MODEL

In this section, we describe the general framework of the equilibrium model we propose. Any special application of such a model to a national health care system must take into account the available data and the questions and problems the planners want to answer. Our examples will be drawn from the Quebec health care system. In this system, the main problems relate to planning the development of resources on a district basis in order to ensure equal access to quality health care programs at the least cost.

#### An Overview of the Model

Figure 1 summarizes a framework of analysis for such a system. "Input" shows the units of resources available per category and subcategory. These quantities could be the number of physicians per specialty available in the system under study, the number of beds available per subcategory of hospitals or for services like radiology, the number of machines or the number of technicians available. The units at this level should correspond

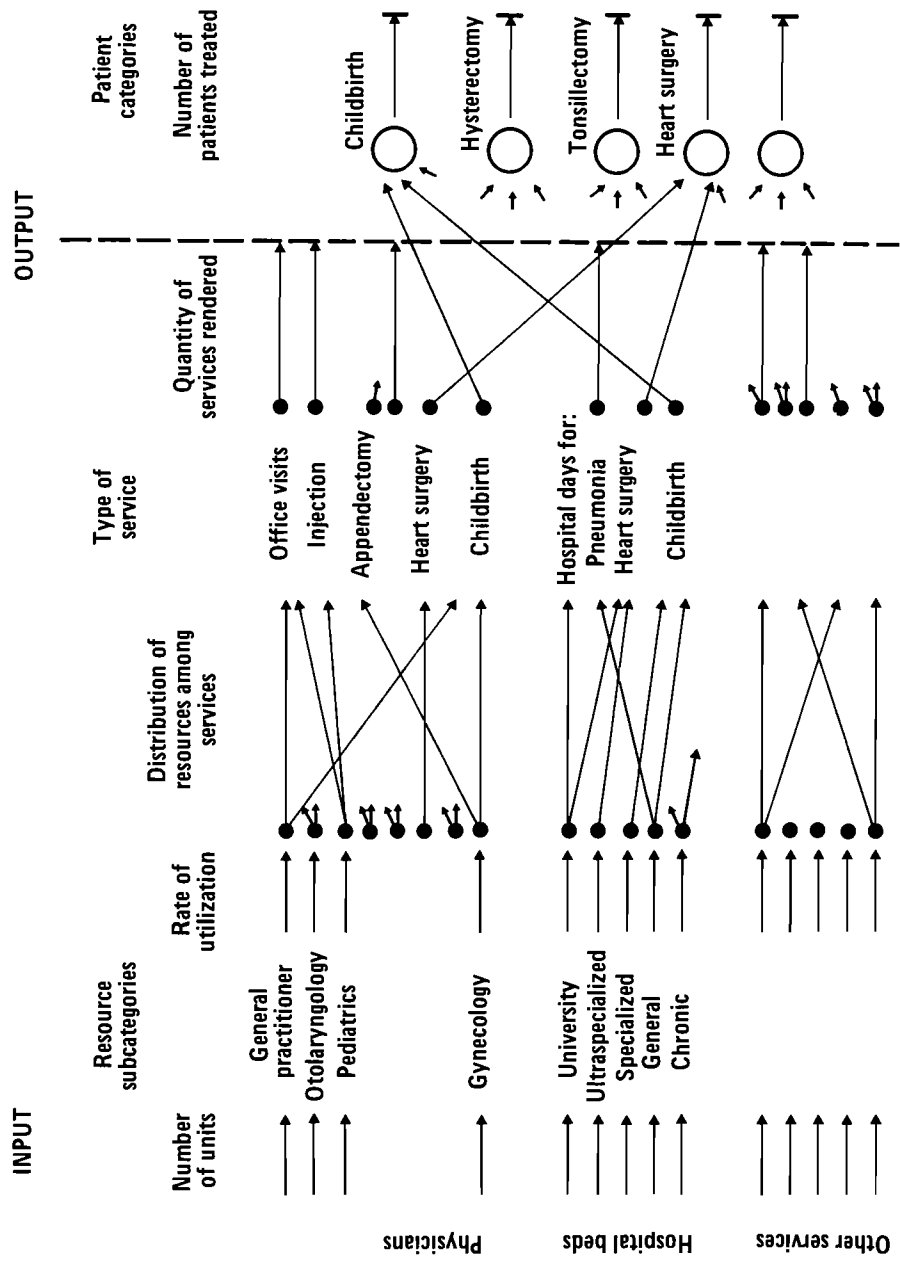

Figure 1. A global health care flow model.

as much as possible to the units used by the planners and decisionmakers in establishing their programs. The level of disaggregation of the resources is again related to the problem studied and the data available.

These resources are then allocated to different types of health services. At this step, there is an independent set of services for each broad category of resources (e.g., physicians, hospital beds). The interactions among these categories is considered only in the following step. These types of services are, for example, specific surgeries or group of surgeries, office visits, categories of tests, bed-days for specific diagnoses or surgeries, etc.

We would now expect to find as the output of the model (at the right of Figure 1) the number of patients treated per category and the resources they consume. However, it may not be possible to allocate certain resources to specific categories of patients, or in certain cases it may be difficult to calculate the number of patients treated given the resources allocated to a patient category. We can either compute the number of services rendered or, for well-identified patient categories or packages of services, we can compute the number of patients treated. For the equilibrium of the system, it is important to create patient categories or packages of services where there is a high level of interactions among different categories of resources. For example, surgery requires an appropriate surgeon and a hospital bed in an appropriate hospital for a certain duration. On the other hand, a number of physician visits and diagnostic tests could be done without any specific relation to a particular or well-identified disease. Also, some types of hospitalization may not be essential in all cases and result from the physician's decision coupled with available beds. In the latter two cases, interactions among resources are not essential. In any given system, the level of interactions to consider will be dictated by the context of utilization of the model together with the calibration tests. The system from input to output will be controlled by the function to be optimized. Now we will describe the type of function used to generate the equilibrium sought.

#### The Basic Cost Function

Given a set of inputs, output is found by optimizing the cost function of the different flows in the model. For each pertinent flow, we generate a convex cost function as follows. We use a desired value ( $\gamma_a$ ) that is estimated in some cases from the viewpoint of resources and in others from that of demand. This function should also have increasing marginal cost in any direction away from the desired value and should include a mechanism to weight each flow for its tolerance ( $\sigma_a$ ) of being pushed away from its desired value. Such a function is described in



Figure 2. As we go along, we indicate possible ways of estimating the value of  $\gamma_a$  and  $\sigma_a$ . In our preliminary work, we used the following analytical form:

$$f_a(x) = \left( \frac{x - \gamma_a}{\sigma_a} \right)^2 .$$

Other forms, nonsymmetric for example, could be used.

### The Rate of Utilization of Resources

As we said previously, there are incentives--either monetary or self-preservation--for using each resource at a certain level. Certain factors, however, could force use of a resource over its desired level, for example, pressure from an incompressible demand (e.g., childbirths, broken bones) or pressure from the desired rate of utilization of other resources (e.g., pressure on hospitalization by surgeons). Other reasons as well could force a resource to be used under its desired level, such as a lack of demand (for delivery beds, for example) or the absence of enough other resources to generate the desired consumption. This is modeled through the basic cost function. The desired rate of utilization of a resource may be estimated from the average utilization either in the whole system or in a part of it where a satisfactory (for the resource) equilibrium is judged to have been attained. In turn, the coefficient of tolerance  $\gamma_a$  may be estimated from the standard deviation of the mean utilization of resource  $a$  in the system. At this point, the model has a flow of resources in proper units to be distributed among the different types of services. In Quebec, for example, the dollar would be

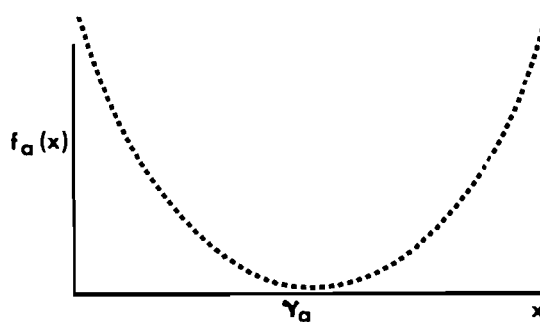

Figure 2. The basic cost function.

used as the unit for the medical resource. In other systems, physician time would be more appropriate. For the hospital beds resource, the suggested unit is bed-day.

#### The Distribution of Resources to Health Services

This step deals with the problem of substitution or competition among health resources to render a given service. For example, a medical procedure such as childbirth, hysterectomy, or setting a fracture may be performed by any of several specialists. In the same manner, a patient could be hospitalized either in a university, ultraspecialized, specialized, or general hospital, and in some cases at a chronic hospital. For each health resource, there is a preconceived pattern of utilization and a perceived role in the health care system. This tendency is also modeled through the basic cost function. For each feasible arc  $a$  between a resource and a service, we generate a desired value  $\gamma_a$  and a tolerance  $\sigma_a$ , both of which are calculated from the data available in the system. For our application in Quebec, we computed the average practice (percent of efforts per type of services) of the physicians per specialty for each district, and we calculated  $\gamma_a$  and  $\sigma_a$  from the mean and standard deviation of these averages.

This part of the system has been tested in Quebec for medical resources with a fixed rate of utilization and a fixed level of output per service type. The results obtained were quite satisfactory [5,6].

#### Quantity of Services Rendered

If when applying the model to a particular situation, one does want to consider the interactions between medical and hospital resources, the model can be terminated at this step. Even if interactions are considered through packages of care or categories of patients treated, one could choose to have some outputs of the system that are not channeled through these packages or categories. Previously, the cost functions introduced reflected the preferences of the resources, whereas here this function is determined by the population's desire to consume. Its satisfactory level of consumption ( $\gamma_a$ ) for these services should be estimated from the data available. In the same manner, the tolerance factor  $\sigma_a$  should quantify the variability and the relative capability of the demand to adjust to the supply. We are presently calibrating such a model with variable rates of utilization of the medical specialities and variable outputs of medical services using up to 500 types of services that represent over 90 percent of the total consumption of the medical resource. We will soon be able to report on this model.

### Number of Patients Treated

Ideally, this step would be handled similarly to the previous one, using the basic cost function with  $\gamma_a$  and  $\sigma_a$  representing the desired number of patients treated together with a coefficient of tolerance. However, the function relating the number of patients treated to the quantity of resources attributed to a category of patients is difficult to estimate and calibrate. In fact, an increase of resources for a category of patients may generate both new patients and an increase in resource consumption. The average consumption of resources per patient could either increase or decrease depending on the average consumption of new patients.

Thus to use categories of patients or packages of services as the model's output requires knowing or assuming a relation between the number of patients and resources consumed. Hence definition of the categories or packages should be done carefully in order to include the interactions to be modeled but to exclude as much as possible consumption behaviors hard to model. For example, the package of care for a cholecystectomy (gallbladder operation) could be defined as the medical procedure and a fixed number of days of hospitalization. Such a definition is relatively fixed and represents the main interaction between resources. Thus it is not necessary to add office visits and medical tests to this package, as they may vary in number and may depend on the availability of the resources in a manner difficult to calibrate.

Therefore, at this step definition of the model is delicate; it balances between introducing the necessary interactions and the difficulty in relating precisely the number of patients to the quantity of resources consumed. This balance can be attained for any problem only after several iterations of calibration.

### THE MATHEMATICAL FORMULATION AND SOLUTION APPROACH

We will use a flow diagram for presentation of this model. However, the solution to this model cannot be based on a flow structure because of the limits imposed on the size of the problem that we can solve. Mathematically, the system is written as the optimization of a nonlinear function subject only to a non-negativity constraint on its variables. This can be achieved by defining a variable for each possible path in the flow diagram and by writing the cost function in terms of these variables. If the subscripts  $r$ ,  $s$ , and  $p$  refer, respectively, to a given resource subcategory, a type of service, and a patient category (or package of services), the variables of the system are then:

- $X_{rs}$  The quantity of resource  $r$  assigned to the service type  $s$  and not further identified with a patient category or a package of services
- $X_{rsp}$  The quantity of resource  $r$  assigned to the category of patients  $p$  through the service type  $s$

The following sets and constants are also necessary to define the problem:

$R$	{r r is a resource subcategory}
$S$	{s s is a service type}
$P$	{p p is a patient category or a package of services}
$R_s$	{r r is a resource subcategory that can be assigned to service s}
$S_r$	{s s is a service to which resource r can be assigned}
$P_s$	{p s can be assigned to the patient category p}
$S_p$	{s s can be assigned to the patient category p}
$F_r$	The number of units of resource r available
$\bar{\gamma}_r, (\bar{\sigma}_r)$	The mean desired level of utilization (and coefficient of tolerance) for one unit of resource r
$\bar{\gamma}_{rs} (\bar{\sigma}_{rs})$	The mean desired proportion (and tolerance factor) of resource r assigned to service s
$\gamma_s (\sigma_s)$	The amount of resources assigned to service s (and coefficient of tolerance) desired by the population under study. This is defined for any portion of a service that is not channeled to a patient category.
$\gamma_p (\sigma_p)$	The number of patients p treated (and coefficient of tolerance) desired by the population under study

The following values can be calculated from the previous constants and sets:

$\gamma_r = F_r \cdot \bar{\gamma}_r$	The desired total amount of resource r to be consumed
$\sigma_r = F_r \cdot \bar{\sigma}_r$	The corresponding total level of tolerance
$\gamma_{rs} = \bar{\gamma}_{rs} \cdot F_r \cdot \bar{\gamma}_r$	The desired total amount of resource r assigned to service s
$\sigma_{rs} = \bar{\sigma}_{rs} \cdot F_r \cdot \gamma_r$	The corresponding total level of tolerance

We can also obtain the quantity of resource  $r$  used:

$$Q_r = \sum_{s \in S_r} (x_{rs} + \sum_{p \in P_s} x_{rsp}) \quad ,$$

the quantity of resource  $r$  assigned to service  $s$  :

$$Q_{rs} = x_{rs} + \sum_{p \in P_s} x_{rsp} \quad ,$$

and the quantity of resources assigned to service  $s$  but not channeled to a patient category:

$$Q_s = \sum_{r \in R_s} x_{rs} \quad .$$

Obviously it is assumed here that the service types are defined with respect to a given broad category of resources (e.g., physicians, hospitals) and that for any  $s$ , all  $r \in R_s$  are expressed in the same units. However, it is not the case for all resources  $r$  assigned to a category of patients; thus a corresponding quantity  $Q_p$  cannot be calculated.

The resulting objective function is written as follows:

$$\begin{aligned} & K_R \left[ \sum_{r \in R} f(Q_r, \gamma_r, \sigma_r) \right] + K_{RS} \left[ \sum_{r \in R} \sum_{s \in S_r} f(Q_{rs}, \gamma_{rs}, \sigma_{rs}) \right] \\ & + K_S \left[ \sum_{s \in S} f(Q_s, \gamma_s, \sigma_s) \right] + K_p \left[ \sum_{p \in P} f(h_p(x_{rsp}, s \in S_p, r \in R_s), \gamma_p, \sigma_p) \right] \end{aligned}$$

where  $K_R$ ,  $K_{RS}$ ,  $K_S$ , and  $K_p$  are weight factors, to be calibrated for the different terms in the objective function. The function  $f$  is the basic cost function described previously and  $h_p$  is a function calculating the number of patients treated given the amount of resources assigned to the category  $p$ . These functions could be defined as in the British Balance of Care Model [4].

For a function  $f$  as defined previously and well-behaved functions  $h_p$ , this objective function is convex. The only constraints considered are the non-negativity of  $x_{rs}$  and  $x_{rsp}$ .

Very efficient algorithms are available for even large problems of this type. Recently, such an algorithm was tested [8] and applied in another context. A problem with 6000 variables was solved in 20 seconds central processor time on a Control Data Cyber 173.

Our model has 25 medical resources and approximately 500 medical services, and it does not consider patient categories. We expect the resulting number of variables to be approximately 1500. This model will be calibrated on the health care data of the entire Quebec system and on a district level. We hope to help planners and decisionmakers in estimating the effects of increasing physician resources per specialty in a district. When this part of the study is completed, we plan to include hospital resources and packages of care for surgical procedures in the model. Other types of resources will be added later.

#### SUMMARY AND CONCLUSION

A health care system model should be based on the behavior of actors within the system, since the planner has no control over utilization of the system. And such a model should be descriptive rather than prescriptive, because of the state of knowledge and kind of decision being made. We have developed a possible approach for such a model, and have partially tested it on Quebec health care data. We believe that the type of model proposed is both adequate and helpful to the Quebec national health care system. We also believe that it could be adapted to other health care systems even if the data were not as abundant as in Quebec.

#### REFERENCES

- [1] Florian, M., ed., *Traffic Equilibrium Methods*, Proceedings of the International Symposium held at the Université de Montréal, November 21-23, 1974, Springer Verlag, 1976.
- [2] Florian, M., R. Chapleau, S. Nguyen, C. Achim, L. James, and J. Lefebvre, *EMME: A Planning Method for Multi-Modal Urban Transportation System*, Publication #62, Centre de recherche sur les transports, Université de Montréal, March 1977.
- [3] Florian, M., and M. Los, *Impact of the Supply of Parking Spaces on Route Choice*, Publication #86, Centre de recherche sur les transports, Université de Montréal, October 1977.
- [4] McDonald, A.G., G.C. Cuddeford, and E.M.L. Beale, Balance of Care: Some Mathematical Models of the National Health Service, *British Medical Bulletin*, 30, 3 (1974).

- [5] Norbert, Y., *La simulation de la pratique médicale à l'aide d'un modèle de distribution à coût convexe*, Rapport de stage de maîtrise, Département d'informatique, Université de Montréal, août 1976.
- [6] Rousseau, J.-M., *The Need for an Equilibrium Model in Health Care System Planning*, in E.N. Shigan and R. Gibbs, eds., *Modeling Health Care Systems, Proceedings of an IIASA Workshop*, CP-77-8, International Institute for Applied Systems Analysis, Laxenburg, Austria, 1977.
- [7] Illich, Y., *Némésis Médicale: l'expropriation de la santé*, Edition du Seuil, Paris, 1975.
- [8] Ferland, J., F. Soumis, and J.-M. Rousseau, *Descent Techniques to Solve Some Nonlinear Complementarity Problems*, Publication 270, Département d'informatique, Université de Montréal, 1977.

NATIONAL ASPECTS OF GDR COOPERATION WITH THE  
IIASA HEALTH CARE SYSTEMS MODELING TASK

K. Spies

The German Democratic Republic is following with interest IIASA's work with the modeling of health care systems which in our opinion is of great international significance. Modeling is being used increasingly to determine how health care manpower, material, and financial resources can be used effectively, and as a basis for health care decisions that are scientifically substantiated, correct from the point of view of health policy, and sound in their long-term implications. With the aid of models, public health administrators are able to foresee more clearly the consequences of alternative decisions and to establish a decisionmaking strategy.

Decisions affecting health care delivery influence peoples' state of health far into the future. In order to master the increasing complexity of health care services, it is necessary to use not only all relevant scientific knowledge, but in particular systems analysis and modeling and even computerized mathematical simulation.

The health services of any country are strongly influenced by its own social conditions and national characteristics, but all countries have in common the basic human need for health, fitness, and well-being and the desire to satisfy that need in the context of social conditions as well as in accordance with traditional or actual demands of the population.

Because of those common features, it becomes possible to define the basic patterns and functions of a general system of medical care and to establish universal models on the basis of population trends, epidemiological facts, medical-scientific knowledge, and the resources required for each particular care strategy. Of course, such models should be sufficient, flexible, and acceptable.

The data that such models require must be obtained within the framework of the existing health care system and its supporting automatic data processing system. In this connection, the task on modeling of health care systems tackles a fundamental, universal problem. The far-reaching homogeneity of conditions in the GDR, promoted by the socialist system, in terms of demography, epidemiology, socioeconomic development, and ecology --in conjunction with a national health service which is managed and planned centrally and which dispenses well-developed, integrated, and appropriately organized health care delivery--allows



relatively uncomplicated modeling of elements of the health care system with good opportunities for informative evaluation.

Our research mainly focuses on:

- Patient-related data processing in the in-patient sector, with connections to out-patient medical care. Emphasis is placed on the medical aspect (in-patient and out-patient morbidity). Standardized records for in-patients and out-patients are used.
- Developing prevention projects, follow-up care, and computerized registers for, first, targeted care of populations selected according to sociodemographic or nonsociological criteria, and, second, for statistical analysis required in management and research.
- Establishing and developing automatic laboratory and functional diagnosis. Developing screening systems for early detection of latent pathological conditions and premorbidity phases. This can also be used to assess fitness for certain occupations. Automatic processing of measured data and use of computers can optimize the organization of the systems and help assess their benefit for society.
- Establishing automatic information systems to promote the quality and effectiveness of medical care and to support health planning and management.

Much data have already been accumulated for these projects, but the full potential of these data has not yet been realized, that is, for assessing the quality of medical care and its impact on the population's health; for optimizing administration, supply, and planning; and for research.

Our objectives call for increased use of computerized data processing, which in turn requires systems analysis and systems configuration for efficiently integrating automatic information processing with the organization of health care. Consequently, the approach used for testing models in the GDR will be characterized by the use and development of existing systems of medical care and systems of automatic data processing coupled with them.

The ultimate objective is the establishment of a system of medical data banks--both related to institutions and organized on the territorial and central levels--which will allow optimal use of available data for improving medical care delivery and health planning and management.

Models will be introduced by stages. The first stage will be based on systems of health care and screening for selected populations (expectant mothers, infants through infant welfare services, and school-age children through the health service for

children and young people), surveillance of factory workers exposed to occupational health hazards, compulsory mass screenings for selected categories of diseases (mass X-ray examinations for the detection of tuberculosis, bronchial carcinomas, and advanced stages of cardiovascular disease), and extensive investigations of selected groups of patients (diabetics, patients with neoplasms, and those requiring hemodialysis).

These stages have long existed within the socialist health service of the GDR and some are already based on electronic data processing (EDP). They are developing in a planned way, gradually including other diseases and populations. This applies, for example, to a screening program for cardiovascular diseases, soon to be established.

When extending existing systems, we proceed from the needs of the people, taking into account the availability of relevant diagnostic techniques, the possibility of prompt and effective treatment of detected cases, available resources (medical personnel, equipment, etc.), and the effect of health measures. EDP projects used in the context of local health care are being extended and new EDP projects and complex, computerized medical data bases for selected health institutions are being developed.

We expect stimulation in this field from our collaborators at IIASA just as we are willing to contribute our ideas and experiences to the overall project. It appears particularly important in this connection to study thoroughly the capacity for adapting and developing the diverse automatic information systems that have hitherto been established internationally in the fields of medicine and health and social services.

THE UTILITY OF NATIONAL HEALTH CARE SYSTEMS  
MODELING: ONE PLANNER'S VIEW

J.H. Weiss

INTRODUCTION

As an economist, a health care planner, and an occasional policymaker, my experience with the US health care system runs the gamut from planning and policy research at the federal, local, and institutional levels to participating in efforts to gain a more fundamental understanding of the health care system and the basic forces that influence its performance. I have engaged in a bit of model building myself and have supervised the work of other health care systems model-builders. At the other end of the health care job spectrum, I briefly managed a university hospital in New York City.

Since I think of myself primarily as a planner and a doer, I will speak from the practical perspective of a user of health care models. Moreover, I will take the perspective of a national health care planner and ask; What is the potential utility of IIASA's national health care system (HCS) modeling effort to health care planners and policymakers in highly developed countries with their correspondingly complex and institutionalized health care systems? More specifically, what is the likelihood that either of these groups will obtain useful insights for policymaking purposes into the workings of their health care systems? In considering these questions, I will draw on my own knowledge and experience with the US health care system and on existing knowledge and data that describe the system.

The US health care system does, of course, have certain features that may lead some to argue that observations about the utility of HCS modeling to this system cannot be applied generally to other highly developed countries and their advanced health care (AHC) systems. In particular, many observers of the US health care system have described it as a "nonsystem". The amount of control that the government has exercised at various levels over the allocation of health care resources, the distribution of health services, and the manner in which services are delivered has increased significantly in recent years. Yet the US health care system remains relatively unstructured and unplanned when compared to the systems of certain European countries. Nevertheless, there are two reasons why observations based on knowledge and experience with the US health care system should have some significance for other AHC systems.

First, over the past decade the USA expanded enormous amounts of money and effort to obtain a better understanding of the workings of its health care system. (In 1976, the federal government spent roughly \$500 million on health services research, planning, and development.) The huge health services research, planning, and development establishment in the USA, and the proliferation of papers, studies, and sets of data describing and analyzing the behavior and performance of the system are quite impressive. Therefore, I believe that our understanding of the *behavioral* features of the US health care system compares favorably with that of most other AHC systems.

Second, the US health care system is clearly similar in many important ways to other advanced health care systems. Having largely "conquered" infectious diseases, all AHC systems are dealing with the same set of major health care problems such as stroke, cancer, heart disease, and trauma. We are dealing with these problems using roughly the same base of scientific and technical knowledge, although the proficiency with which we apply this knowledge may vary significantly from country to country.

Another key feature that all AHC systems share is that their particular political and institutional characteristics are crucial in determining the results of specific health policy actions. Such features of a health care system as the nature of its physician referral patterns and procedures, the specific rules and regulations governing its financing, the administrative controls (if any) on utilization of the services of the system, and the manner in which work is organized and allocated among the various decisionmaking units of the system, must be understood if one is to understand the relationship between potential policy actions and the likely results of those actions. Knowledge of how the behavior of physicians, hospitals, long-term care institutions, and other decisionmaking units are affected by various system incentives becomes crucial in understanding how a health care system may respond to various policy initiatives.

#### THE BASIC GOALS OF THE HCS MODELING ACTIVITY

The long-term goals of IIASA's HCS modeling activity are very ambitious. The ultimate aim is to build a universal or generic health care model that will help health care planners and policymakers in dealing with a wide variety of policymaking questions and issues. As Kiselev [1] states:

One can enumerate major problem sets which can be solved by means of a dynamic model:

- 1) A precise and motivated foundation of resource needs for a health care system;
- 2) the optimal allocation of funds assigned to a health care system;

- 3) an analysis of the current system state with an evaluation of its resources and potentialities for a large area and its subregions;
- 4) the possibility of obtaining predictions on system development and predicting the consequences of decisions; and
- 5) demonstrating the advantages of this or that health care system.

Kiselev has further stated that: "The only obstacle in the way will be the lack or insufficiency of quantitative data to 'fill in' the dynamic model".

The lack of a detailed understanding of many of the key behavioral relationships of AHC systems, and the general absence of the necessary quantitative information that would enable us to understand and explain these key behavioral relationships, seems to me to be a powerful obstacle to IIASA's development of a generic HCS model that would have important predictive value for policymaking purposes. Quite clearly, for such a model to be useful to health care planners and policymakers, it must be built upon a broad, credible, and accurate information base which just does not exist at this time in the USA-- and I doubt that such exists for most other AHC systems.

The empirical efforts of the Institute to date basically deal with such matters as a morbidity model of degenerative diseases [2]. It is a huge step to move from relatively simple models that describe "biological processes such as morbidity, birth, death, or recovery from diseases" [2] to extraordinarily complex models that explain the behavior of various health care decisionmaking units. In an AHC system, understanding that, for example, the number of persons in a country with certain types of cancer will increase as the population ages, is of relatively little policymaking interest, unless one can also successfully build related predictive models that show how the system's various resources will respond to policymaking variables to affect a variety of health care outcomes that are not in all cases easily measured. While simulation and other predictive models could be very useful for policymaking purposes, especially in evaluating the impact of major (i.e., nonincremental) changes in the health care system, what behavioral assumptions are acceptable in the absence of appropriate, detailed, system-specific data?

The balance of my discussion will explain why I believe IIASA cannot accomplish this "huge step" at this time. I suspect that some of the reasons why I believe that the HCS modeling effort is likely to have relatively little use for policymaking purposes can be applied generically to a large number of countries with AHC systems. Since I did not sense in my review of IIASA papers a full appreciation of the possible limitations of HCS modeling for public policy purposes, I will highlight some of the limitations that may not have been considered fully by the institute's HCS modelers.

REASONS WHY THE HCS MODELING ACTIVITY IS LIKELY TO HAVE LIMITED UTILITY FOR POLICYMAKING PURPOSES

Defining the Goals and Outputs of the System

The task of building a model that would have substantial predictive value would be much easier if the outputs of AHC systems were limited to such readily measurable items as reductions in morbidity and mortality. Although one of the primary goals of any AHC system should certainly be to reduce measurable morbidity and mortality, AHC systems have developed to the point where further significant reductions in morbidity and mortality are very difficult to achieve, even with the application of massive amounts of additional resources.

Other, less readily measurable goals and outputs of the system do become important for policymaking purposes. The distributional issue of who should get health care services is particularly significant. In the USA, increasing the ability of poor people, or people who are geographically isolated, to obtain adequate health services is certainly a goal of many public policymakers. Another key policy issue in the USA concerns the balance of resources devoted to health care services versus other competing national needs. Hence the goal of controlling rising health care prices and costs becomes crucial in preventing the health care sector from absorbing a disproportionate share of the nation's total resources. Further, US policymakers are concerned about the appropriate locus of institutional care, and thus the balancing of resources among hospitals, various types of long-term care institutions, and home care. In this instance, policymakers and planners are interested in the relative costs of alternative modes of care, the "dignity" of the care, the accessibility and convenience to patients of various modes of care, and other considerations that are not easily measured.

Another set of important policy issues in the USA relate to how medical care is organized and delivered, including how physicians are being trained (e.g., family practitioners versus various specialists). Again, many of these goals involve outputs that are relatively difficult to measure and about which we have little information such as: reductions in patient waiting time, convenience of the service to patients, general patient satisfaction, and a reduction in unnecessary "doctoring" which may or may not have measurable adverse effects on the patient.

Moreover, the US health care system is increasingly providing various types of "luxury" health services where the outputs are not readily or directly measurable. These include certain types of psychiatric and social services, health education services, nutritional services, cosmetic surgery, and others.

Because of the complex and diverse goals and outputs of AHC systems, many of the major choices that society must make concerning the allocation of resources within AHC systems mainly

involve political and social determinations rather than technological considerations. HCS models may not be useful in answering such questions as: "Who should get what from the health care system?"--especially if the "what" cannot be readily measured. When the "what" consists of whether or not a person should live out his last several years and die in his home or in some type of extended care facility, political and social judgments based upon the prevailing values of the society, in combination with scanty information about relative costs and outcomes, become decisive in determining the types of services that will be provided by AHC systems.

### The Production Function of Advanced Health Care Systems

The flexible manner in which various inputs of the health care system can be combined to produce a given set of outputs (i.e., the production function) complicates the task of HCS modelers. The great diversity of possible relationships between inputs and outputs necessitates the use of detailed and complete data for describing the production function with enough accuracy as to be useful for policymaking purposes.

Clearly, there is a great deal of substitutability among the inputs in the production of the outputs of the AHC systems. For example, within a fairly broad range, nurses can substitute for physicians and practical nurses and nurses' aides for nurses. Modern technology, in the form of pharmaceuticals and diagnostic and treatment equipment, can substitute for health care personnel. Various types of health care institutions, within certain limits, substitute for one another. For example, studies of patients in acute care hospitals in New York City have shown that about one-third of the patients could readily be cared for in less expensive institutions [3].

The substitutability of health care inputs means that the mix and level of inputs the system should choose to produce a given set of outputs depend, within those fairly broad ranges that are often relevant for policymaking purposes, on behavioral rather than technological considerations. Thus for the HCS model to have any substantial predictive value for AHC systems, the model must indicate with some precision how the mix and level of inputs to produce a given set of outputs will vary in response to various behavioral factors. In the USA, for instance, a model of the health care system using 1960 input coefficients to predict the employment of health care personnel in 1977 would have grossly underestimated the ratio of lesser skilled workers to more highly trained health care personnel. As the system's output expanded from 1960 to 1977, the relative scarcity of highly trained personnel necessitated a substantial substitution of lesser skilled people for physicians, dentists, and so forth.

The responsiveness of the mix and level of inputs of an AHC system to various market and institutional factors necessitates that any model of a AHC system take into account the

dynamic and changing nature of the production function through the use of a great deal of behavioral information. In my judgment, the data required to describe how the production function of the US health care system might respond to various changes in relative input costs in enough detail to be useful for policy-making purposes are not yet available (and I suspect that these requisite data are not available for most AHC systems).

The physician supply issue is an example of the type of policy-relevant question that is important to US health care policymakers which cannot be answered by utilizing currently available data in a HCS model. Federal government policies regarding medical education have mandated planned increases in the capacity of US medical schools. As a result, the number of physicians employed over approximately the next 10 years will increase by 40 to 50 percent. One would like answers to the following types of questions in assessing the potential impact of this very large increase in the supply of physicians.

1. How will this increase in the supply of physicians affect morbidity and mortality in the USA? We do not even have enough knowledge and data to estimate the direction of the effect of this sizable increase in the supply of physicians on the health status of the population. It is quite possible that in some areas of the USA "over-doctoring" may have a negative impact on the measurable health status of segments of the population.
2. Where will these physicians locate? Although behavioral models that give some insights into the factors affecting physician location exist, these models were based on data from time periods when the supply of physicians was increasing very slowly. It is not clear that the same behavioral relationships will exist when there is a marked increase in the supply of physicians.
3. How many hours per year will the average physician be willing to work once this large increase in physician supply is absorbed by the health care system?
4. How will this sizable increase in physician supply affect the demand for physician assistants and other support personnel? Although we know that the direction of the effect will be to reduce the demand for auxiliary personnel, there is no base of behavioral information that would allow us to make a reasonable prediction about how the demand for physician assistants and other supportive personnel might be affected by this very large change in the supply of physicians.

These questions also illustrate that behavior that shows up as gaps or problems at the macro system level needs to be described and understood at the micro level if the HCS model is to have any



substantial predictive value. Furthermore, a detailed and reasonably complete understanding of behavior at the micro system level can often only be obtained through a review of fragmented data drawn from limited studies or from the results of unsystematic "natural experiments".

An additional problem in describing and quantifying the production function of a AHC system is that the measurable outputs of the system (e.g., morbidity and mortality rates) are not readily affected by major changes in the inputs of the system. In the USA, one can observe across states very disparate ratios in the number of physicians and other health care resources to population, with no apparent discernible effect upon health status indicators. Similarly, if one compares the US and Canadian health care systems--two systems with basically very similar levels of health care technology--the Canadian system uses 40 percent more hospital beds in relation to its population than the US system. Yet, the measurable outputs of the two systems are very similar.

The preceding exemplifies Gibbs' statement that: "behavior simulation models are relatively difficult to build since they require an intimate understanding of the workings of the HCS and relatively difficult to apply since they usually require data (for parameter estimation) on the preferences and priorities within the HCS that may not readily be available" [4].

#### Institutional and Political Considerations

In making national health care policy decisions, a country's particular, institutional and political characteristics are very important, and these characteristics cannot be reflected adequately in a generic (or often even a country-specific) mathematical HCS model. Country-specific institutional and political characteristics certainly limit the generic nature of any HCS model, since the structure of the model may change significantly when it is applied from one system to another.

A major health care policy issue in the USA is what form of national health insurance, if any, should the country adopt. One facet of this issue concerns alternative mechanisms for controlling health care costs. The sharp rise in US health care costs over the past decade is one reason why the percentage of the US gross national product devoted to health care has increased from about 6 percent in 1966 to nearly 9 percent today.

Any appraisal of the potential efficacy of alternative cost control measures must be based on a detailed examination of the behavioral features of the US health care system. Various predictive models could be used to make judgments about the efficacy of alternative cost control policies, but these necessarily somewhat qualitative models must be based upon a sophisticated understanding of US institutions [5]. For instance, one key question

regarding any national health insurance plan is exactly how should it be financed? Some proponents of particular health insurance plans have urged that funds for health care be segregated into a "trust fund". Other health insurance plans have been proposed without any earmarking of funds to a special health "trust fund". These various financing schemes have potentially very different implications for future rates of increase in US health care costs. Financing the system via a "trust fund" might, under certain conditions, lead to a much higher rate of inflation than the alternative of not earmarking funds for health. Nevertheless, detailed knowledge of US health and political institutions is needed in order to appraise the conditions under which the preceding statement might be valid.

It is necessary to analyze the responses of the system to highly specific policy instruments. Much of this process involves integrating information concerning the behavioral and technical features of the system in such a way that reasoned judgments can be made about future behavior. There is no way in which this crucial analytical process of reasoned judgments, usually based on very fragmented pieces of information, can be adequately reflected in any generic, mathematical model of an AHC system. Consequently, no responsible policymaker or planner would rely upon any generic, mathematical health care model, because he knows that the crucial policy variables and relationships that he is concerned with cannot be reliably described by such a model.

Moreover, in view of the lack of comprehensive, detailed behavioral information about the US health care system, it is difficult to envision how even a country-specific HCS model could be used with any degree of confidence to answer many of the important questions about the national health insurance issue. The available behavioral information is, in general, just too fragmented and spotty. The necessity of integrating a variety of complex political and institutional considerations into the analysis in order to form some reasonable judgments about the future behavior of institutions and individuals requires relying on a variety of somewhat qualitative models.

#### CONCLUSIONS

I question the comparative advantage of IIASA's undertaking a very ambitious and difficult HCS modeling project for several reasons. First, the necessary behavioral data required to develop a model with enough detail and reliability to facilitate public policy decisions are probably not available. Country-specific institutional and political factors are important in determining the responsiveness of each country's health care system to particular policy instruments. The crucial nature of these factors in determining the best solution(s) to the particular health care problems of countries with advanced health care systems gives national health care organizations a very substantial

comparative advantage in framing and analyzing alternative solutions to their own countries' problems. Country-specific behavioral relationships are of paramount importance, as compared to technological or biological relationships, in understanding and developing solutions to many of the health care problems facing AHC systems. It is difficult to envision how a generic HCS model can reliably and usefully take these complex relationships into consideration.

I suspect that the portions of the HCS modeling work that will likely prove most useful are those that depend heavily on technological or biological relationships (e.g., predictions of future morbidity patterns), rather than behavioral factors. Also, the modeling work may be useful insofar as it might systematically identify key gaps in the empirical knowledge about particular health care systems.

On balance, the comparative advantage of IIASA might be better put to use in exploring alternative solutions to health care problems which: (1) tend to depend heavily on technological solutions that are often transferable from country to country, or (2) affect several countries simultaneously. Examples include the protection and improvement of the biosphere, the development of policies and procedures for the international establishment of regulatory standards for drugs, and the coordination of biomedical research among countries.

This assessment of the potential use of the HCS modeling project is based on the assumption that IIASA is a place where persons with quite disparate backgrounds and points of view can have a friendly, frank, and useful exchange of ideas about subjects of common interest.

#### REFERENCES

- [1] Kiselev, A., *A Systems Approach to Health Care*, RM-75-31, International Institute for Applied Systems Analysis, Laxenburg, Austria, 1975.
- [2] Kaihara, S., I. Fujimasa, K. Atsumi, and A. Klementiev, *An Approach to Building a Universal Health Care Model: Morbidity Model of Degenerative Diseases*, RM-77-6, International Institute for Applied Systems Analysis, Laxenburg, Austria, 1977.
- [3] Leveson, I., and J.H. Weiss, *Analysis of Urban Health Problems*, Halsted-Wiley Press, New York, 1976.
- [4] Gibbs, R.J., *Health Care Resource Allocation Models--A Critical Review*, RM-77-53, International Institute for Applied Systems Analysis, Laxenburg, Austria, 1977.
- [5] Holahan, J., W. Scanlon, and B. Spitz, *Restructuring Federal Medicaid Controls and Incentives*, UI 986-12, The Urban Institute, Washington, D.C., 1977.

AN EPIDEMIOLOGICAL MODEL TO EVALUATE  
THE ACTION OF A RISK FACTOR

P. Le Beux, P. Goldberg, J. Chaperon,  
C. Veyssier, M. Goldberg, and F. Gremy

INTRODUCTION

The development of health care system models is becoming a major concern in the field of biomedical systems analysis [1,2,3] due to the need to better understand the dynamics of health care systems. Some previous work, such as the MEDICS project [4,5], dealt with a global approach to existing systems in order to obtain insights for future planning [6]. In this paper, the approach is less ambitious and is based on the work of the IIASA research group on health care systems [1].

The model proposed by A.A. Klementiev [1] describes the evolution of a morbid degenerative process on a given population. Using the survival curve of the morbid process on a given population, it is possible to compute for each year the number of people subject to the morbid process for  $n$  years. The incidence rate is used to compute the number of individuals entering the morbid process. Before that event, the population is considered healthy.

In the Klementiev model, the exit of the individuals from the process is represented by mortality due to the following causes: (1) the morbid process itself, or (2) other causes independent of the morbid process.

The variables used in this model [1] are:

$H_i$ : healthy population in class age  $i$ ;

$P_i$ : number of individuals in the  $i$ -th stratum;

$\mu_i$ : incidence rate;

$D_i$ :  $\bar{D}_i - D_i^*$  ;

$D_i$ : mortality rate due to all other causes of death, where  $\bar{D}_i$  is the general mortality rate and  $D_i^*$  is the specific mortality rate;

$\beta_{ij}$ :  $D_{i+j} + d_{ij}$  ;

$d_{ij}$ : mortality rate of individuals at age  $i$ , caused by the specific diseases contracted  $j$  years ago.

In matrix form the model equations are:

$$S = P - H = (\mu H)'A ,$$

$$P\bar{D} - HD = (\mu H)'B .$$

The elements of matrices A and B are a function of  $\beta_{ij}$ . Therefore it is possible to compute  $\mu$  and H and finally S, which is the prevalence of the morbid process.

AN EPIDEMIOLOGICAL APPROACH: RISK FACTORS AND ENVIRONMENT

The previous model (Figure 1) is only valid for degenerative diseases, and no attempt is made to take into account the environment and the associated risk factors. But here we extend that model into an epidemiological model (Figure 2) which includes the concept of risk factors.

Considering a given risk factor R and any specific disease M (degenerative or not) associated with this risk factor, the population can be divided into three groups: H, healthy individuals not exposed to R; E, healthy individuals exposed to R; and S, individuals who have contracted disease M due to risk factor R.

The Environment and Risk Factors

A risk factor is a recognized factor that can induce any kind of disease, including a nondegenerative disease. A risk factor may be biological, physical, social, or economic in nature, and the set of risk factors constitute the environment of a given population.

As shown in Figure 2, some of the exposed individuals can return to the healthy group corresponding to his or her age stratum. It is necessary to model this return by a special function.

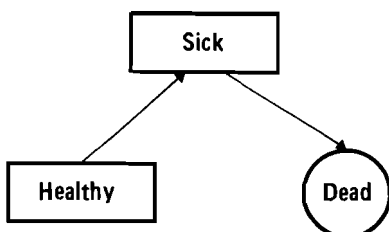

Figure 1.

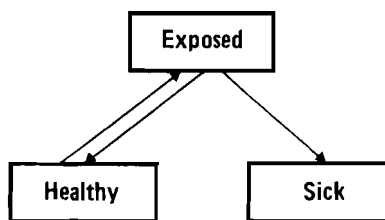

Figure 2.

Consequently, the exit from the risk process can be divided into three causes: (1) death from a cause independent of a particular risk factor, (2) a morbid process due to a specific factor, and (3) a return to the population not submitted to the risk factor by means of suppression of the risk factor.

### Variables of the Model

Using an approach similar to the morbidity model defined by Klementiev, the population is age-sex structured into N classes. The i-th class is characterized by the same types of variables, namely,  $P_i$  represents population in the i-th stratum, and  $h_i$  represents healthy population not submitted to the risk factor R. However, in our model a new variable  $v_i$  is defined as the exposition rate of the risk factor R on the population  $h_i$ .

Instead of considering the mortality statistics as in [1], the following morbidity estimates are introduced:  $\bar{M}_i$  is the general morbidity, specific to age class i;  $M_i^*$  is the specific morbidity due to the risk factor R; and  $M_i = \bar{M}_i - M_i^*$ .  $M_i$  is the specific morbidity not due to the risk factor R. It should be noted that  $M_i$  for the degenerative or chronic diseases can be obtained from the Klementiev model.

Similarly, variable  $r_{ij}$  is defined as the specific morbidity rate, which can be considered the number of individuals who contracted a specific disease at age i after being exposed to a risk factor during j years. From  $r_{ij}$  it is possible to define a new variable  $\gamma_{ij}$ :

$$\gamma_{ij} = M_{i+j} + r_{ij} .$$

A new variable  $s_{ij}$  is defined as the rate of individuals in the i-th age class who were exposed to the risk factor R for j years but who are no longer exposed.

It should be noted that for some risk factors, when j reaches a certain level, i.e., when an individual has been exposed for a long time to a particular risk factor, it is likely that he or she will never return to the healthy population. In this case,  $s_{ij}$  would be equal to zero.

### THE MATHEMATICAL MODEL

Using the previously defined variables, the following dynamic model diagram can be presented:

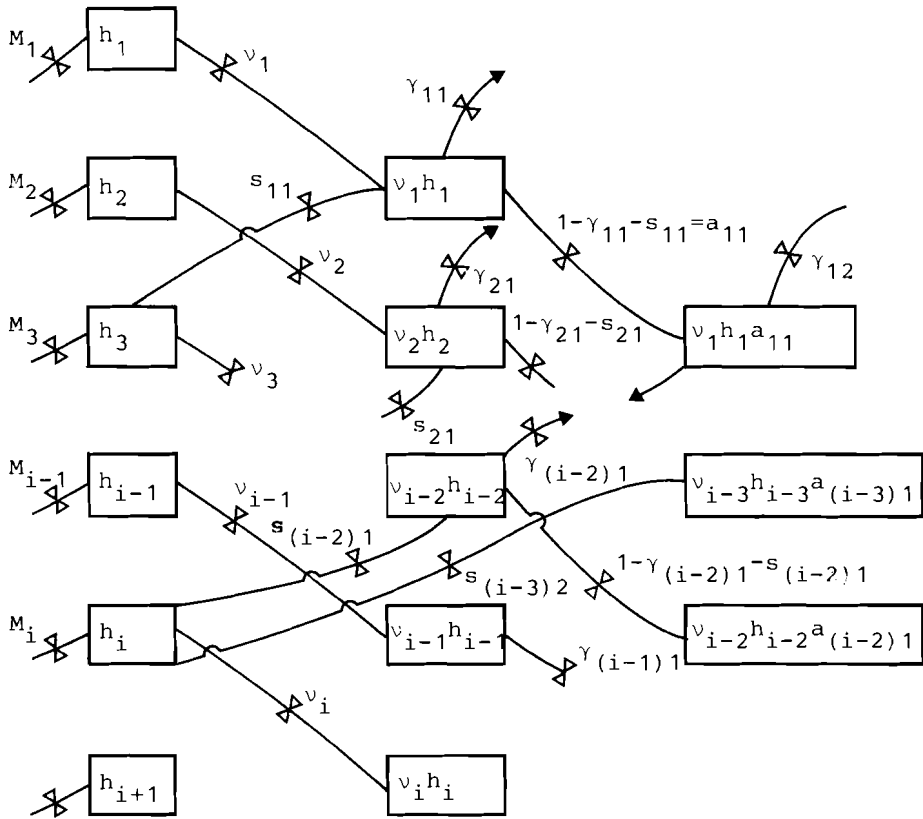

where  $a_{ij} = 1 - \gamma_{ij} - s_{ij}$  .

The equations of the model can be obtained by considering each age class and writing the balance of population in the various states represented by the levels of each population subset. Therefore:

$$P_1 = h_1 \quad ,$$

$$P_2 = h_2 + v_1 h_1 \quad ,$$

$$P_3 = h_3 + v_2 h_2 + v_1 h_1 (1 - \gamma_{11} - s_{11}) + v_1 h_1 s_{11} \quad ,$$

$$\begin{aligned}
 p_4 &= h_4 + v_3 h_3 + v_2 h_2 (1 - \gamma_{21} - s_{21}) \\
 &+ v_2 h_2 s_{21} + v_1 h_1 (1 - \gamma_{11} - s_{11}) s_{12} \\
 &+ v_1 h_1 (1 - \gamma_{11} - s_{11}) (1 - \gamma_{12} - s_{12}) \quad , \\
 &\qquad \qquad \qquad \vdots \\
 &\qquad \qquad \qquad \vdots
 \end{aligned}$$

$$\begin{aligned}
 p_i &= h_i + v_{i-1} h_{i-1} + \sum_{j=2}^{i-1} v_{i-j} h_{i-j} a^{(i-j)} (j-1) \\
 &+ v_{i-2} h_{i-2} s^{(i-2)} (i-2) \\
 &+ \sum_{j=3}^{i-1} v_{i-j} h_{i-j} a^{(i-j)} (j-1) s^{(i-j)} (j-2) \quad ,
 \end{aligned}$$

with  $a_{ij} = \prod_{k=1}^j (1 - \gamma_{ik} - s_{ik})$  .

Another system of equations can be obtained by considering the sick population in each class: the left-hand side is equal to  $p_i \times \bar{M}_i$  and the right-hand side in each stratum is the sum of levels which represent the population affected by the specific disease.

$$p_1 \bar{M}_1 = h_1 M_1 \quad ,$$

$$p_2 \bar{M}_2 = h_2 M_2 + v_1 h_1 \gamma_{11} \quad ,$$

$$p_3 \bar{M}_3 = h_3 M_3 + v_2 h_2 \gamma_{21} + v_1 h_1 a_{11} \gamma_{12} \quad ,$$

$$p_4 \bar{M}_4 = h_4 M_4 + v_3 h_3 \gamma_{31} + v_2 h_2 a_{21} \gamma_{22} + v_1 h_1 a_{12} \gamma_{13} \quad ,$$

$$p_i \bar{M}_i = h_i M_i + v_{i-1} h_{i-1} \gamma^{(i-1)} (i-1) + \sum_{j=2}^{i-1} v_{i-j} h_{i-j} a^{(i-j)} (j-1) \gamma^{(i-j)} j \quad .$$



From the previous section it becomes:

$$h_1 = p_1 \quad ,$$

$$v_1 = \frac{p_2(\bar{M}_2 - M_2)}{p_1(\gamma_{11} - M_2)} \quad ,$$

$$h_2 = p_2 \frac{\gamma_{11} - \bar{M}_2}{\gamma_{11} - M_2} \quad ,$$

and we designate

$$V_i = \sum_{j=2}^{i-1} v_{i-j} h_{i-j}^a (i-j) (j-1) + v_{i-2} h_{i-2}^s s_{i-2}$$

$$+ \sum_{j=3}^{i-1} v_{i-j} h_{i-j}^a (i-j) (j-1)^s (i-j) j \quad .$$

Thus

$$p_i = h_i + v_{i-1} h_{i-1} + V_i \quad . \quad (1)$$

Similarly, we define

$$T_i = \sum_{j=2}^{i-1} v_{i-j} h_{i-j}^a (i-j) (j-1)^\gamma (i-j) j \quad .$$

Thus

$$p_i \bar{M}_i = h_i M_i + \gamma_{i-1} h_{i-1}^\gamma (i-1) 1 + T_i \quad . \quad (2)$$

Therefore solving (1) and (2) yields:

$$v_{i-1} = \frac{p_i (\bar{M}_i - M_i) + T_i - V_i M_i}{h_{i-1} (\gamma_{(i-1)1} - M_i)}$$

and

$$h_i = \frac{p_i (\bar{M}_i - \gamma_{(i-1)1}) - T_i + V_i \gamma_{(i-1)1}}{M_i - \beta_{(i-1)1}} .$$

#### RESISTANCE TO A RISK FACTOR

In the previous systems of equations, the population variable P and the morbidity variable M are considered known. For the degenerative diseases, M can be obtained from the Klementiev model. For the nondegenerative diseases, M can be obtained from statistical data on morbidity.

The variable r is probably the most difficult to evaluate. However, it is an important epidemiological variable which can be called the resistance to a risk factor curve, and it is a concept similar to the survival curve used in [1]. For the most important risk factors, this variable should be obtained by specific epidemiological studies. Such data are now essential to the fields of preventive medicine and public health. Knowing r and M, it is possible to compute  $\gamma$ .

The variable s is also difficult to evaluate. It can be obtained from a survey of a population no longer exposed to a given risk factor. Such a survey must be carried on for long enough periods to take into account the delayed actions of certain risk factors.

Knowing the previous variables, it is now possible to compute the values of the variables v and H. Such variables are probably useful to public health decisionmakers concerned with prevention problems.

#### CONCLUSION

This model differs from Klementiev's model by introducing the possibility of individuals returning to the population H. It could be used to extend Klementiev's model to nondegenerative morbidity. Such a morbidity model could be connected to the risk factor model and such would give a general epidemiological model of the complete morbidity process: (1) action of a risk factor (which can be modified), (2) disease (which can be cured), and (3) death.

The proposed model is still a conceptual tool. This is essentially due to the lack of data in the public health field, including data on morbidity associated with risk factors. Another limitation is due to the lack of knowledge concerning the action of multiple risk factors having several dimensions: physical, chemical, ionizing, as well as social and economic.

Consequently, the next step will be applying the proposed model to a limited problem concerning a well-studied risk factor such as tobacco or alcohol and their associated diseases.

#### REFERENCES

- [1] Klementiev, A.A., *On the Estimation of Morbidity*, RM-77-43, International Institute for Applied Systems Analysis, Laxenburg, Austria, 1977.
- [2] Venedictov, D.D., *Modeling of Health Care Systems*, in *IIASA Conference '76*, CP-76-7, International Institute for Applied Systems Analysis, Laxenburg, Austria, 1976.
- [3] Kaihara, S., et al., *An Approach to Building a Universal Health Care Model: Morbidity Model of Degenerative Diseases*, RM-77-6, International Institute for Applied Systems Analysis, Laxenburg, Austria, 1976.
- [4] MEDICS, *MEDICS, rapport d'activité 1973-1974*, Ministère des Affaires Sociales Ed., Direction Générale de la Planification, Montréal, Canada, 1973-1974.
- [5] Le Beux, P., J. Chaperon, and Cl. Chastang, *Un modèle dynamique du système de santé*, Proceedings of the Journées d'Informatique Médicale, IRIA Ed., Rocquencourt, France, 1976.
- [6] Chaperon, J., P. Le Beux, Cl. Chantang, and M. Goldberg, *A Dynamic Epidemiological Model of the Health Care System*, Proceedings of MEDECOMP 77, Online Conferences Limited ed., Uxbridge, England, 1977.

## ENVIRONMENT AND HEALTH

Å.E. Andersson and I. Holmberg

### INTRODUCTION

During the last four years, a research group at the University of Gothenburg has been engaged in the integration of economic, social, and demographic models. The basic assumption is that the development of the environment as a natural science system is closely related to social, economic, and demographic development, the latter variables representing phenomena with a high degree of interdependence. Thus sociologists have aimed at theories and models of demographic development in which economic, social, and demographic-biomedical variables are studied under assumptions of more or less complete interdependence. It goes without saying that such a strategy of theoretical development and model-building is extremely complicated. As a result of the differences in the theoretical development of demography, economics, and other social sciences, integration at the theoretical level implies unifying methodological approaches. Mathematical methods have become an essential part of such unified interactive model building.

One of the most important problems is to find those variables common, directly or indirectly, to all these fields of research. The selection of such variables can hardly be done by a cursory inspection of theories in the different disciplines. It is possible for us to analyze the economic system, the demographic system, and so on from a theoretical and even axiomatic point of view, because within these disciplines we have been able to create a strategy for the study of interdependencies at both the theoretical and applied levels. The basic research strategy is depicted in Figure 1.

While it is possible to model the internal structure of each system with formal methods, it is hardly possible at the current stage of knowledge to have such a formal approach to the analyses of the interdependencies between systems. We have instead chosen to analyze these along the lines of "soft modeling". The Low Income Survey of Sweden shows by means of a principal component analysis that a rather small set of variables from different disciplines has to be part of an integrative social, economic, biomedical, and demographic system study. These variables are:

- employment status,
- health and morbidity,

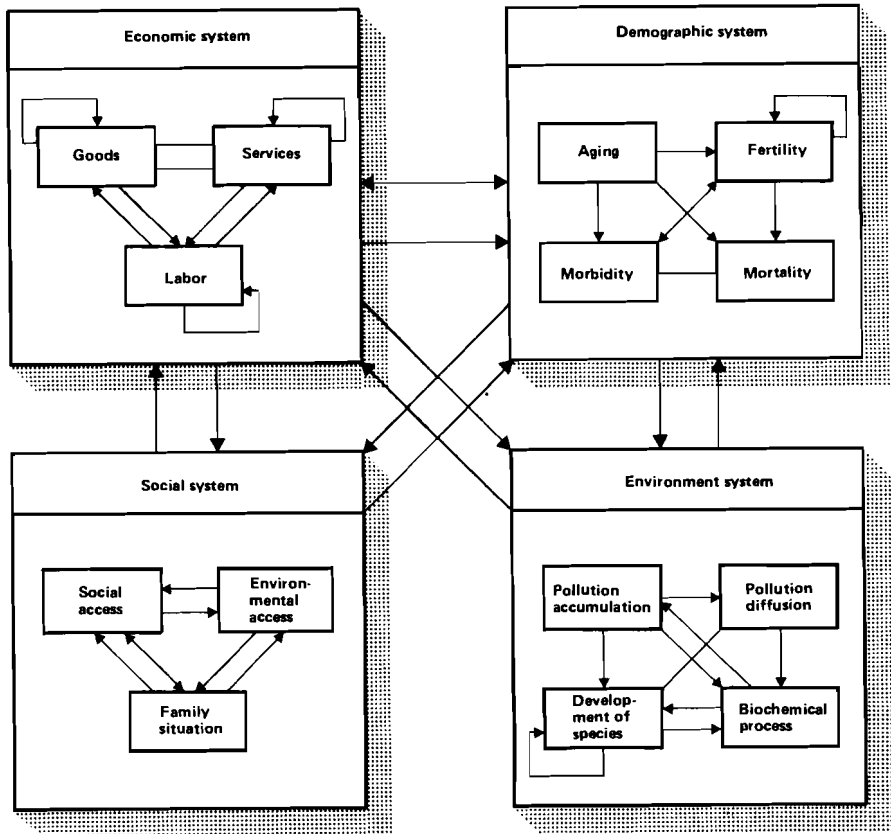

Figure 1. The basic structure of the interdependent economic, demographic, environmental, and social systems.

- family income and consumption patterns,
- social contacts and internal family environment,
- housing, basic environmental characteristics, and accessibility to different kinds of privately and publicly administrated capital.

One of the most important results of this analysis is the highly structured pattern of interactions latent in the observations. Most of the variation in the employment variables can be explained by less than five factors, and, in the case of health, most of the variation is explained by less than 10 factors. All other important variables, mentioned above, are explained by a similarly limited number of factors.

During the last 10 years, there has been greater interest in the interactions between the economic and biological subsystems. Environmental decay is related to the level and structure of production, while economic development is clearly influenced by environmental constraints. Thus there is an important interdependency between environmental, (including biological) factors and parameters, and variables of the economic system. For the demographer, the interdependency with the quality of environment has always been recognized if not properly modeled.

This paper will highlight some of the empirically quantifiable measures of interactions between economic, demographic, and social factors on the one hand and different variables, indicating the health status of individuals, on the other.

#### ECONOMIC DEVELOPMENT AND WORK ABSENTEEISM

Empirical analyses of health and morbidity and their relationship to the economic, social, and natural environment are often based on data on mortality. In such studies, the dependent variable can at best give indirect evidence of the influence of the broadly defined environment on health. In most cases mortality represents a drastic culmination of a disease process. A modern health program in an advanced economy cannot reasonably be restricted to these drastic culminations; it must be oriented to even small changes in health status. The problem is, however, that no measures of the development of the health status of a large number of individuals living in very different conditions are available in any data bank that also contains information about the general environment of the same individuals. However, some countries have records of insurance policy-regulated work absenteeism. In countries that have general health insurance systems, such as Sweden, this type of register almost completely covers all strata of the population with the exception of persons below or above working age.

However, a problem does exist in using workers' absenteeism records as a basis for morbidity studies. Absenteeism from work can be recorded as a consequence of some disease, but in some cases it is in reality the individual's regulation of the actual number of working hours. It is hardly probable that all individuals have the same valuation of their leisure time as it is regulated by the legal institutions. A simple economic analysis shows that the number of working hours is highly dependent upon the general standard of living as measured by the wage rate, and that it is also regulated by the individual's level of education. Other factors, such as distance between housing unit and workplace, can have a significant influence. In most countries, there seems to be a structural difference between male and female labor in the average number of working hours.

A study of cross-sectional material from a large number of nations at different levels of economic development shows a very

strong negative correlation between the number of working hours and the level of economic development. Time-series studies for the Swedish economy also show that the number of working hours decreased from approximately 3000 hours per year in 1960 to approximately 1850 hours in the mid-1970s.

Such macro data are, of course, only a rough indicator of the real relation between different background variables and working hours per capita. A regression equation based on a Swedish micro data base for the Stockholm metropolitan area gives the following result:

$$LH = 36.4 - 0.2 \cdot w + 1.10 \cdot E + 7.6 \cdot S$$

where LH represents working hours per week; w, wage rate in kronor; E, education in years; and s, sex (female = 0, male 0 1).

This equation shows that if no medical certificate is associated with worker absenteeism, one should expect certain groups to deviate from the legally enforced number of working hours per week by reporting absenteeism. According to Swedish health insurance legislation, it is quite possible to stay at home for a limited number of days without presenting any medical certificate. This means one must distinguish between short- and long-term absenteeism if any conclusions about morbidity are to be validly inferred from statistically measured relations between registered morbidity and background variables. In fact, we have the problem of interpretation shown in Figure 2. To this comes an unknown number of persons who have reported themselves ill to their ordinary employers but not to the health insurance system.

#### THE STRUCTURAL APPROACH TO AN ANALYSIS OF INTERACTIONS AMONG MORBIDITY AND ECONOMIC, SOCIAL, AND TECHNOLOGICAL ENVIRONMENT

An analysis of worker absenteeism centers around four problem areas. The fundamental dependent variable is the employee's *total absenteeism* as measured by relative or total time absent from work. The cause of the employee's absence may be either self-diagnosed or certified by a doctor. A large number of explanatory variables are used in connection with the latter type of absenteeism which generally refers to illness of more than one week's duration.

The first class of explanatory variables comprises *individual characteristics*, including: age, sex, marital status, occupation, occupational status, birthplace, and income. This information may be obtained from the local health insurance office.

The following three classes of explanatory variables represent environmental factors that may have a specific and also separable effect on workers' absenteeism: the housing unit, work place, and transportation system.

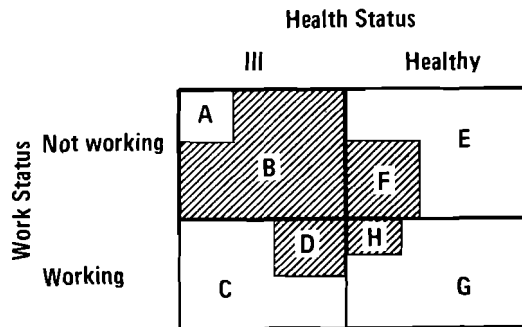

Shaded areas represent cases reported to the health insurance system.

Key:

- A. Abnormal cases (e.g., research workers)
- B. Complete identification
- C. Social pressure or inadequate insurance system
- D. Insurance fraud
- E. Unemployed
- F. Persons with deviation between actual and desired working hours fuzzy
- G. Complete identification
- H. Insurance fraud

Figure 2. Interpretation of reporting of absenteeism to the health insurance system based on health status and work status.

The *housing unit* is one of the most important centers of gravity in the individual's activity field. Thus housing standards should be included as one explanatory variable in an exhaustive study of morbidity and worker absenteeism. On the other hand, it might be difficult to separate the pure housing effect from selective processes that regulate the individual's choice of housing area.

Disregarding these objections for the time being, we have given each individual an area code on the basis of their stated place of permanent residence (given on the health insurance record). Each one of these areas may be characterized by type of



housing (detached houses, terrace houses, block of flats, etc.), average age of the houses, type of apartment (number of rooms, modern equipment, central heating, etc.), and environmental characteristics (parks, intensity of exploitation, accessibility to recreation areas, population density, air quality as well as social, commercial, and cultural services).

Another important center of gravity in the individual's activity field in his *workplace*. In the coding process, we gave each individual both the area code of his workplace and an industry code according to the international standard classifications of industries. On the basis of these codes, it is possible to classify each workplace with regard to a large number of environmental characteristics such as: size and age of the plant, internal conditions (temperature, noise, draft, air pollution), and employment structure. From the occupational code, it is possible to characterize the individual's position within the workplace with respect to monotony, stress, physical strain, prestige, economic responsibilities, shift and "on-call" conditions, noise, and temperature variations usually connected with a certain occupation in a specific industry.

Figure 3 shows the analytical process of worker absenteeism. As this figure shows, the *transportation system* is an important link that connects the individual's place of residence and workplace. Discussions with experts on transportation research have convinced us of the necessity of including qualities of the transportation system among the explanatory variables. The transportation system is characterized by travel times, walking distances, and traffic standards by various means of transportation. The main reason for including the transportation system in our analysis is the strong relationship between the characteristics of the transportation system and the accident risks during travel to work.

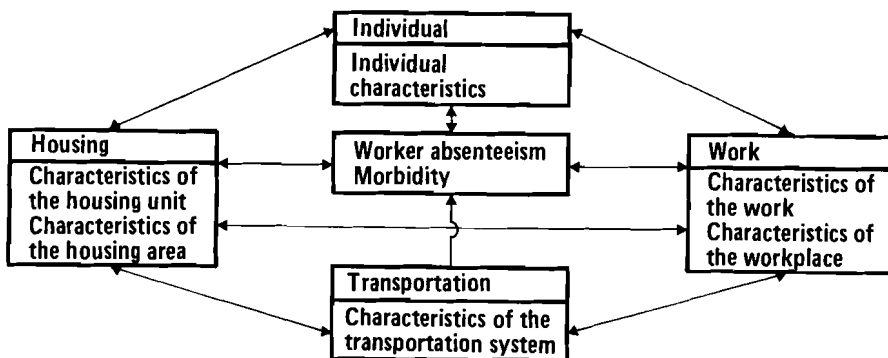

Figure 3. The analytical process of worker absenteeism.

THE STATISTICAL METHOD

In analyzing the empirical patterns of this interactive system, there is little basis for assuming any specific form of equations or even patterns of interactions to a larger extent than already given in Figure 3. Instead, we have decided to use an information theory approach [1,2,3]. This approach is illustrated by the following examples. A contingency table can be formed to represent all potential interactions. A very simple example of such a contingency table is shown in Table 1. The marginal totals are assumed to be given. If there were no structural relations in the material, we would expect the actual infarction ratio to follow the figures reported in the four cells of the interior of the contingency table.

It is commonplace among all kinds of research workers to study the actual occurrence of nonstochastical phenomena with such a contingency table as the starting point. One can also compute the information content of the table as:

$$\sum_{ij} p_{ij} \log \frac{p_{ij}}{q_{ij}} = I(p,q)$$

where  $p_{ij}$  equals the posterior probability distribution and  $q_{ij}$  equals the prior probability distribution. The posterior probability distribution  $p_{ij}$  minimizes  $I(p,q)$  that is chosen. One can show that this measure is approximately equal to  $\chi^2$  if the observed and expected frequencies are close to each other.

Table 1. Sample contingency table, myocardial infarction.

		Age		Total
		Low	High	
Myocardial Infarction	Yes	500	500	1000
	No	2500	2500	5000
	Total	3000	3000	6000

We will now enlarge the above contingency table by subdividing the high-age and the low-age groups into males and females. In the same way, we will subdivide the infarction classification into persons with and without high blood pressure. The result will be an age by sex by infarction by blood pressure table that has  $2^4$  (16) cells. It is now possible to give this new set of information by four different two-dimensional contingency tables and test each one separately with the  $\chi^2$  or the information theory method. Another approach would be to compress all information into the 16-cell table 2. This table is an interactive one in the sense that we can separate statistically the influence of high blood pressure from the effect of age and sex on the infarction rate, but we can also test other reasonable patterns of interdependencies. Under the hypothesis of complete independence, one would expect to find numbers in each cell corresponding to the formula

$$j_{ij} = \frac{n_{i.}}{n_{..}} \cdot n_{.j} \quad .$$

These numbers are given in the body of the table.

Table 2. Expanded sample contingency table, myocardial infarction.

		Age				Total	
		Low		High			
		Males	Females	Males	Females		
Myocardial infarction	No	LP	225	225	225	225	900
	Yes	HP	25	25	25	25	100
		LP	250	250	250	250	1000
	Total	HP	1000	1000	1000	1000	4000
			1500	1500	1500	1500	6000

Key: LP = low blood pressure  
 HP = high blood pressure

Chi-square is generally employed to test statistically the hypothesis of independence in a contingency table. When we have a simple  $2 \times 2$  table, it is easy to show that the calculation of the  $\chi^2$  is the same as finding out whether the odds-ratio is equal in the two groups according to one of the classifications. In our example shown in Table 2, we test whether the odds for infarction are equal in the low- and high-age groups.

It may be advantageous to describe each one of the cell frequencies as generated by a multiplicative process. Regarded in this way, the frequency is made up of a number of "main effects" corresponding to the classifications employed and a number of "interaction effects". In our enlarged example above, the main effects correspond to age, sex, blood pressure, and infarction, and the interaction effects are: six two-factor interactions of the type age  $\times$  sex, age  $\times$  blood pressure, and so on; four three-factor interactions of the type age  $\times$  sex  $\times$  blood pressure; and one four-factor interaction, age  $\times$  sex  $\times$  blood pressure  $\times$  infarction. When frequencies are regarded in this way, a test of independence is equivalent to testing whether the interaction effects deviate significantly (in the statistical sense) from zero.

The method generally employs a transformation that gives a linear model in log-frequencies. If  $f_{ijkl}$  represents the frequencies in the four-dimensional contingency table, then the log-linear model is given by:

$$\begin{aligned} \log f_{ijkl} = v_{ijkl} = & \mu + \lambda_i^A + \lambda_j^B + \lambda_k^C + \lambda_l^D + \lambda_{ij}^{AB} \\ & \lambda_{ik}^{AC} + \lambda_{il}^{AD} + \lambda_{jk}^{BC} + \lambda_{jl}^{BD} + \lambda_{kl}^{CD} \\ & \lambda_{ijk}^{ABC} + \lambda_{ijl}^{ABD} + \lambda_{ikl}^{ACD} + \lambda_{jkl}^{ABCD} + \lambda_{ijkl}^{ABCD} \end{aligned}$$

where  $\mu$  is the grand mean;  $\lambda_i^A$  etc., the main effects;  $\lambda_{ij}^{AB}$  etc., the two-factor interactions;  $\lambda_{ijk}^{ABC}$  etc., the three-factor interactions; and  $\lambda_{ijkl}^{ABCD}$  etc., the four-factor interaction.

The  $\lambda$ -effects are regarded as deviations that add up to zero in every dimension:

$$\sum \lambda_i^A = \sum \lambda_j^B = \sum \lambda_k^C = \sum \lambda_l^D = 0 \quad ,$$

$$\sum_i \lambda_{ij}^{AB} = \sum_j \lambda_{ij}^{AB} = \dots \sum_i \lambda_{kl}^{CD} = 0 \text{ and so on.}$$

This is the completely saturated model, which includes all possible effects. An estimate of the various effects in the model is obtained by keeping all marginal sums fixed. An iterative procedure, iterative proportional fitting, which starts from 1's in each cell, is employed to fit the chosen model. The frequencies are adjusted successively to add up to the given (fixed) marginal sums.

A special case arises when one of the variables used for classification can be regarded as dependent and having only two levels.

Define

$$P(A = 1) = \frac{e^{\beta X}}{1 + e^{\beta X}} ,$$

where X equals a vector of independent variables and  $\beta$  equals a vector of parameters. Then

$$\psi = \log(A) = \log \frac{p}{1-p} = \beta X .$$

In the example above, infarction can be regarded as the dependent variable. We then arrive at the following logit model:

$$\begin{aligned} \text{Logit (A)} &= \frac{P(A=\text{level } 1)}{P(A=\text{level } 2)} = 2\lambda_1^A + 2\lambda_{1(j)}^{AB} + 2\lambda_{1(k)}^{AC} \\ &\quad + 2\lambda_{1(1)}^{AD} + 2\lambda_{1(jk)}^{ABC} + 2\lambda_{1(j1)}^{ABD} + 2\lambda_{1(k1)}^{ACD} + 2\lambda_{1(jk1)}^{ABCD} \end{aligned}$$

since terms not including A cancel out and

$$\sum_i \lambda_{ij} = \sum_k \lambda_{ik} = \dots \sum_i \lambda_{ijkl} = 0 .$$

The example given in the section above can be extended into any number of dimensions of a contingency table, although there

will be limitations of a numerical or data collection nature. It goes without saying that a subdivision into 10 interactive factors, each one represented by highly disaggregated subdivisions, is an immensely large table with approximately 10 million cells. In this case, a total census from one of the larger countries would be required to estimate such a model with any reasonable precision.

It is thus obvious that there is no basic conflict between an approach along these lines and more puristic approaches employing axiomatic analyses of the theoretical structure of the problem. There must be some reasonable assumptions *á priori* about the structure of interactions to make a multidimensional contingency table analysis meaningful. The advantage of this approach compared to ordinary regression analysis is that it can handle highly qualitative variables. We do not require any assumptions about statistical error distributions.

It must be observed that a transformation of the model from its structural form to a form with explicit logits means that a causal relation is actually being assumed in cases where the first stage of the analysis has only revealed an interdependency. No logits can be computed without *á priori* assumption about a causal relation.

#### USING HEALTH INSURANCE DATA IN PLANNING AND FORECASTING

We will discuss the uses of estimates of relations between absenteeism and environmental variables in this section.

The basic use of probabilities of work absenteeism is in the prediction of labor supply per unit of labor. The model of economic development is described in Figure 1. A set of parameters  $\{a_{lj}\}$  indicates the use of labor per unit of output. One parameter,  $a_{11}$ , indicates the use of potential labor time for leisure. If  $a_{11}$  goes up, growth will go down, *ceteris paribus*. Forecasts of worker absenteeism are thus crucial to the forecasting of economic growth, whether it is caused by sickness or by a reduction of propensity to work. The demand for health care is indicated by a socially and privately determined demand function,  $a_{h1}(x,d,H)$ , where the  $x$  vector indicates the structure of production and the  $d$  vector indicates the demographic structure. The  $H$  vector indicates the characteristics of the health system (e.g., price, queuing parameters, output policy).

We can now write the economic system in the following concise form:

$$\dot{x}(t) = A(x,t) X(t) + B(x,t) \dot{X}(t) ,$$

where

$x(t)$  is a vector of production volumes in different sectors,  $i$ , and regions,  $r$ ,  
 $= \{x_i^r(t)\};$

$A(x,t) = \{a_{ij}^{rs}(x,t)\}$ , a matrix of production- and time-dependent input-output parameters;

$a_{11}^{rr}(x,t)$  and  $a_{hl}^{rs}(x,d,H,t)$ , elements of this matrix; and

$B(x,t) = \{b_{ij}^{rs}(x,t)\}$ , a matrix of production- and time-dependent capital-output ratios.

It can be shown that this model will always have an economically feasible solution with a possible rate of growth or decline. This solution will among other things depend upon the demand for leisure time and health care. It will also depend upon the efficiency of the health care system as measured by their input-output and capital-output ratios. Another important use of the analysis is in the demographic model in which morbidity, as measured by long-term absenteeism, can be used as an intermediary factor in the prediction of fertility and mortality. We can thus measure the following causal or interdependent relations shown in Figure 4.

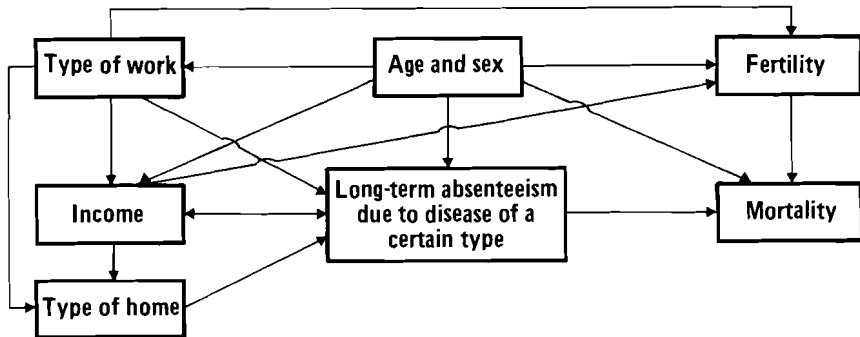

Figure 4. Causal or interdependent relations found in a demographic model.

SOME EMPIRICAL RESULTS FROM THE GOTHENBURG STUDY

The morbidity of a population can be described by a large number of different measures, for example, total number of reported cases during some predefined time period, average duration of each case, or, as is done in this section, total worker absenteeism during a year. The latter distribution, taken from the 1975 study of Gothenburg workers' absenteeism, is described in Table 3.

The distribution is highly skewed and the proportion with zero days absenteeism is around 30 percent. Only about 3 percent of the persons in the sample had total absenteeism exceeding 180 days and 8 percent had a total time exceeding 90 days. The sick absenteeism was dominated by cases of much shorter durations: 22 percent had a total absence time of between one and six days and an addition 12 percent were absent from work between one and two weeks during the year.

In the analysis to be presented here total absentee time during the year has been treated as a dependent variable in a regression analysis. Explanatory variables have been chosen according to a factor analysis of characteristics of the occupation and industry. Instead of using factor scores as independent variables in the analysis, we have chosen those variables that have the highest loadings on each factor. The advantage of using such a procedure is that possible dependencies are easier to explain since we always know the exact meaning of the variable used in the regression. The greatest advantages in using factor scores would be that we obtain independent explanatory variables. On the other hand, it is often very difficult to explain the exact meaning of the factors.

Table 3. Total worker absenteeism, Gothenburg, 1975.

<u>Duration of absenteeism in days</u>	<u>Percentage distribution</u>
0	30.4
1-6	22.2
7-13	11.6
14-29	13.3
30-89	14.9
90-179	5.0
180-	2.6



For our regression analysis, we used the following variables to describe the characteristics of the industry: size, process industry, manufacturing industry, other commodities production, and public activities. To describe the characteristics of the occupation, the following variables were chosen: external status, supervisory position, ergonomics, freedom in work, contact with others, and chemical health hazards. The characteristics of the individuals are represented by age, sex, marital status, citizenship, income, and region of birth.

Sex, marital status, and citizenship were used in the regression analysis as classification variables and were thus not included directly in the analysis. In addition to this, the age interval was subdivided into ages above and below 30 years. The estimated regression equation was specified as follows:

$$D = A_0 a^{\alpha_1} . y^{\alpha_2} e^{\beta_1 X_1 + \beta_2 X_2 + \beta_3 X_3 + \beta_4 X_4 + \beta_5 X_5 + \beta_6 X_6 + \beta_7 X_7 + \beta_8 X_8 + \beta_9 X_9 + \beta_{10} X_{10}}$$

where D = total time absent during the year,

a = age,

y = income,

X<sub>1</sub> = manufacturing industry,

X<sub>2</sub> = public administration,

X<sub>3</sub> = other commodity production,

X<sub>4</sub> = process industry,

X<sub>5</sub> = size of plant,

X<sub>6</sub> = ergonomic strains,

X<sub>7</sub> = supervisory position,

X<sub>8</sub> = contact intensive occupations,

X<sub>9</sub> = occupation with external status,

X<sub>10</sub> = occupation with chemical health hazards.

The X<sub>i</sub> are all binary variables (0,1).

The results of the regression analysis are summarized in Table 4. The main results may also be summarized as follows:

Table 4.

Category	Explanatory variables											
	Age	Income	Size	Public adm.	Contacts	External status	Super-visor	Ergonomy	Chemical health hazards	Manufacturing industry	Process-industry	Other commodity production
Total sample	-	+	+	+	0	-	-	+	+	0	0	0
Males	-	+	+	0	0	-	-	++	0	0	0	0
Females	--	++	0	0	0	-	0	+	+	0	0	0
Swedish citizens (males)	-	+	0	0	0	--	-	++	0	0	0	0
Other citizens (males)	0	0	0	0	0	0	0	+	0	+	0	+
Swedish citizens (females)	--	++	0	0	0	-	0	+	+	0	0	0
Other citizens (females)	0	++	0	0	0	-	0	++	0	0	0	+
Males < 30 years	-	++	0	0	-	0	-	+	0	0	-	+
Males ≥ 30 years	0	0	0	0	0	--	-	++	0	0	0	0
Females < 30 years	0	+	0	0	0	0	0	+	0	0	0	0
Females ≥ 30 years	-	++	0	0	0	-	0	+	+	0	0	0
Manufact. industry (total sample)	--	0	+	0	0	0	0	+	+	..	0	0
Non manufact. ind. (total sample)	--	++	0	+	0	--	--	+	0	..	0	0
Public, employed (total sample)	-	+	0	..	0	-	--	+	+	..	..	..
Non publ. empl.	-	+	+	..	0	0	-	++	+	0	0	0
Married males	0	0	+	0	0	--	-	++	+	0	0	0
Non-married males	-	+	0	0	-	-	0	+	0	0	0	0
Married females	0	++	0	0	0	-	0	+	+	+	0	0
Non-married females	--	+	0	0	0	0	-	+	0	0	0	0

- *Ergonomy*, that is, characteristics of the occupation that lead to ergonomic problems, is a factor related to increased absenteeism for all groups included in the analysis.
- *External status* and *supervisory position* have a negative relation to total time of absenteeism, that is, occupations with these characteristics generally have a shorter duration of sick absenteeism over the year than others.
- *Age* is by and large negatively related to absent time but a closer analysis of the two groups under and over 30 years of age gives a deviating result. For men, the negative relation is found for those below 30 years of age, but at higher ages the relation is no longer statistically significant. For females, the relation is the opposite: no statistically significant relation for ages under 30 years but an apparent negative relation for ages over 30 years.
- *Income* is generally positively related to the total absentee time, that is, higher income leads to larger total absenteeism. Also in this case, different results are obtained if the age interval is subdivided into ages under and over 30 years. For ages below 30 years, the positive relation remains but for ages over 30 years, the relation is no longer significant, that is, total absentee time is independent of income. On the other hand, for females the positive relation between income and absenteeism is strengthened for ages over 30 years.
- *Chemical health hazards* connected with the occupation clearly lead to an increased absenteeism. Particularly exposed are groups working in the manufacturing industry, the public sector (health care), and women over 30 years.
- *Size* of the plant leads to increased absenteeism only for people working within the manufacturing industry.

#### REFERENCES

- [1] Bishop, Y., S.E. Fienberg, and P.W. Holland, *Discrete Multivariate Analysis. Theory and Practice*, MIT Press, Cambridge, Mass., 1975.
- [2] Goodman, L., The Analysis of Mutlidimensional Contingency Tables: Stepwise Procedures and Direct Estimation Methods for Building Models for Multiple Classifications, *Technometrics*, 13, 1 (1971).
- [3] Ku, H.H., and S. Kullback, Interaction in Multidimensional Contingency Tables: An Information Theoretic Approach, *Journal of Research of the National Bureau of Standards - Mathematical Sciences*, 72B, 3 (1968).

## DISCUSSION

The discussion of health care systems modeling by international organizations and IIASA's national centers was chaired by Dr. Bailey. He began by observing that the morning's presentations seemed to be polarized between mathematical models with their algebraic complexity and the practical problems confronting planners in their day-to-day activities. He stressed the importance of demonstrating the validity of models and of assuring that administrators find them credible. He felt that one question that must be asked of a model is, "Will administrators understand and accept it?" Finally, Dr. Bailey called upon the conference participants to try to bring modeling and practical decisionmaking together by means of a structured discussion.

Dr. Graham then stated that his point of view about modeling is diametrically opposed to that put forward by Dr. Weiss. Dr. Graham noted that policymakers in the UK had argued similarly about the shortcomings of models, but that modelers and planners had finally reached some measure of agreement based on the following considerations:

- The more complex the system, the more models are needed. If a model is correspondingly complex, it does not prevent action but, rather, facilitates conscientious decisionmaking.
- All decisionmakers, politicians as well as administrators, use models, although these are most often not explicitly formulated. It is the task of modelers to bring to light the implicit assumptions and tradeoffs that planners are making.
- Model-builders often have the most success when politicians and administrators are unaware that they are being affected. Through confrontation with explicitly formulated models, decisionmakers are often encouraged to evaluate consciously their own implicit models.
- Most often the problem with models is not that they give false *solutions*, but rather that the modeler is posing the wrong *questions*.
- Finally, modeling should be considered just a part of the decisionmaking process which will be supplemented by moral judgments and other considerations.

Dr. Weiss replied that he does not reject models, but rather appreciates their utility per se. He felt only that it

is dangerous to try to build a general model with a global target. The chances for a successful model are much greater if it has a narrow target.

Dr. Spies said that he supported modeling efforts and felt that they have a valuable potential for assisting decisionmaking. However, he felt that the assumptions of some existing models must be modified. For instance, consumption of medical care may not necessarily equal the availability of care. Often full-fledged information campaigns are needed to encourage people to take advantage of medical services, such as vaccinations. Dr. Spies added that such factors as "fashion" may influence demand for care--for instance, cosmetic surgery. He emphasized that such "demands" do not necessarily correspond to "need". Dr. Spies also noted that consumption is often manipulated, e.g., through the advertising campaigns of pharmaceutical companies.

Dr. Spies then returned to the epidemiological model presented by Dr. Le Beux. He felt that the model is too simple for application to the field of infectious disease; for instance, it does not include subclinical cases in which a person may not even be aware that he is a disease carrier. He stressed that such awareness may be created through interaction with the social system, as public health educators; the process of creating awareness should be subject to more analysis.

Dr. Le Beux then clarified the properties of his model. He explained that the model does not necessarily handle risk factors in a linear manner, nor does the model assume that all people exposed to a risk factor will become sick. He added that it is possible for a person to remove himself from the "exposed" population, as by stopping smoking.

Dr. Spies noted that within the exposed population there are three possible reactions to infection: self-protection, subclinical infection, and illness.

At this point, Dr. Bailey stressed that the discussants should decide how much detail it would be productive to go into. He added that an elaborate systems model for gonorrhoea and influenza would be of great importance in industrial societies; models of other infectious diseases could be best applied in developing countries.

Dr. Rousseau then spoke up in defense of modeling. He felt that modeling makes possible a greater understanding of how a system functions, and that modeling can also give policymakers insight into the impact of their decisions. Furthermore, Dr. Rousseau explained, if a model gives credence to a hypothesis, for instance, that the working environment influences health, planners' thinking may be affected. This could occur even if the model is not implemented in the planner's own country. Dr. Rousseau stressed that model building helps one to uncover false a priori assumptions. Finally, Dr. Rousseau noted that

modelers must take into consideration that one effect of meeting needs may be to create more needs. For instance, building roads may result in more traffic and thus in a need for more roads.

The discussion then turned to Dr. Andersson's environment and health model when Dr. van Eimeren asked if productive or non-productive health outcomes are explicitly included in the model. He mentioned that in the case of absenteeism other workers could do a colleague's tasks with no economic loss. Another example would be the replacement of a dead child. He wondered how such cases were handled in Dr. Andersson's model. Dr. van Eimeren also felt that researchers should concentrate more on such problems as the validity of concepts and economies of scale.

Dr. Asvall emphasized that one should specify what one's objectives are in using models. He felt that it is necessary to distinguish between models that look at the consequences of certain allocation policies and models that investigate the impact of decisions on health outcomes. In his opinion, even simple models of the former type, which say nothing about outcome, could be valuable at the national decisionmaking level, for at the present time, most federal ministries do not have a good overview of the health care system as a whole. Models that show the impacts of a decision broaden the knowledge of ministries and bring more rationality to planning. For this reason, any model that gives a good overview can be very productive. On the other hand, models that try to investigate the influence of a policy on health outcomes must be very detailed and look at a clearly demarcated problem, such as health care for hemophiliacs. Dr. Asvall felt it would be valuable for IIASA to continue working on large-scale models of the health care system. He wondered if it would also be possible for the IIASA team to carry out a very detailed study of a narrow problem to try to link policymaking with health outcomes.

Dr. Kaihara then elaborated on the change in the "medical awareness factor" over time, as measured in his health care simulation model. He explained that awareness of health problems increased in his study population over time. An attempt was made to correlate this change with a social index and it appeared that awareness increased as wealth increased. Dr. Kaihara also noted that public health education too has a great effect on awareness about specific diseases. He concluded with the statement that the usefulness of his model must be proven by testing it with real statistics.

As the morning's discussion drew to a close, Dr. Gibbs addressed the question of the usefulness of the IIASA health care systems models. He conceded that in the early phases of the modeling project the goals were too ambitious and should have been regarded instead as aspirations. However, he stressed that, as had been demonstrated on the previous day, the project's work was now proceeding with much more modest goals. Dr. Gibbs noted that the prevalence models do have universal usefulness as they

had been implemented in France and the GDR. He also noted that the resource allocation model is being used at the present time by planners in the UK.

Dr. Gibbs acknowledged that it is difficult to communicate with planners, but that an important aid is a link with national institutions. Such a link makes it possible to clarify the complex structural aspects of a national health care system, which must be considered in the parameterization and implementation of a model in a particular national context.

Dr. Fuchs-Kittowski turned to the problem of obtaining reliable data for use in health care modeling. He pointed out that the type of data available differs according to the country being studied. For instance, in the USA the best morbidity data are collected through random sample surveys of the population. He concluded by saying that modeling, however problematic, does bring a scientific approach to decisionmaking.

The morning's discussion was brought to a close by Dr. Andersson, who elaborated on his economic model of environment and health. He explained that his model was directed toward equilibrium-disequilibrium processes rather than optimization. He noted, too, that it is best to study economies of scale from the point of view of technology. Speaking of the way the death of children is handled in his model, Dr. Andersson explained that children are not a part of the productive economic sector, but are considered consumers of medical resources.





PART III

Development of National  
Health Care Systems Modeling



FUTURE DIRECTIONS FOR THE IIASA HEALTH  
CARE SYSTEMS MODELING TASK

E.N. Shigan

In 1978-79, the Health Care Systems Task will continue to work in three main directions on the elaboration of the national health care systems model: experimental, scientific, and technical.

DIRECTION ONE

The experimental (applied) method is the continuation of experimentation on all previously elaborated IIASA models (POPULATION, MEMOD, AMER, DRAM) in different IIASA NMO countries. The regional headquarters for Europe of the World Health Organization (WHO) could lend us some support in this respect. When testing these models in a number of countries, it should be noted that there is an estimated deviation depending on different socioeconomic and other situations found in these countries. By means of the same methodology, it is possible to compare existing health care systems in these countries and to aid WHO in its decisionmaking process.

DIRECTION TWO

Our scientific direction is a reflection of further development of the existing model and the elaboration of new computer submodels. As seen from the report on the AMER model, it is based on the aggregated data on all kinds of diseases as well as on aggregated resources. During 1978-79, attention will focus on the elaboration of *disaggregated models for estimating resource requirements*. For this purpose, information on the different classes of the International Classification of Diseases, and the structure of manpower, beds, and other health care resources will be used. The elaboration of such a model requires a great deal of "routine" and scientific data. The development of this approach depends importantly on the support of different national centers, especially on their supplying information.

The *health manpower model* is aimed at forecasting the requirements of different manpower resources, including doctors, nurses, and undergraduate and postgraduate trainees for the various specialties. This model will be elaborated in collaboration with the Systems and Decision Sciences Area.

*Modeling interaction among internal and external subsystems of the national health care system.* In the modeling process, attention will be focused on the relationship of the different hierarchical levels (vertical relationship) to different subsystems of the same level (horizontal relationship). Taking into consideration the health care system's great dependence on the external system, it is also foreseen that we will simulate the relationship of the internal medical subsystems to various socioeconomic, environmental, etc. factors.

Since the national health care systems model is oriented toward the decisionmaker, great attention will be paid to his or her participation in and experience with the modeling process. Existing misunderstandings between the decisionmaker and model-builder mainly depend on their different professional experience and knowledge. Thus investigation of the decisionmaking experience in different situations, its generalization, and mathematical description is very important for modeling national health care systems.

The *behavior of the decisionmaker* will be studied in its different situations, times, and regions (Gabrovo-Bulgaria, southwest region of the UK, etc.).

### DIRECTION THREE

The technical direction of the activities of the Health Care Systems Task is very closely connected with IIASA's Informatics Task. It may be possible to arrange for the exchange of medical information, programs, and models with the help of the computer network system. Such remote use of the IIASA and other computer models elaborated at different centers will speed up the process of modeling health care systems and will make the utilization of these computer models easy for decisionmakers who may be allocated very far from the computer center.

Previous experiments conducted at IIASA between computer centers at IIASA and Bratislava (Czechoslovakia) have shown practical use in this direction. The technical relationship of the IIASA Modeling Health Care Systems Task with national computer centers and WHO (at its headquarters as well as its office in Copenhagen) will be very fruitful for both sides. But, above all, the activities of the small Modeling Health Care Systems Task at IIASA closely depends on the activities and support of national and international centers and on collaboration within IIASA.

SOCIOECONOMIC INFLUENCES IN HEALTH  
AND HEALTH CARE MODELING

P. Fleissner\*

INTRODUCTION

Every simulation model in the field of systems analysis results from an abstraction process; it is not possible to model the real world as it is, nor is it possible to reproduce reality on a computer. Rather, one is obliged to simplify the complexity of the sector under investigation by means of a theory. Such a theory should reflect the essential elements and processes of the sector in question.

If we apply these very general considerations to health care modeling, we must immediately ask: "Which concept of health and illness is (or should be) used to construct a health care model?" We must keep in mind that the type of model, the variables, and the interrelations always reflect the scientist's point of view and his or her concepts about illness, health, and health care. Of course, the model will also reflect--if the model is oriented toward empirical testing and practical application--the limitations of available data and the existing health care information systems.

A review of the literature yields numerous ways of looking at health, illness, and the health care system (HCS). Seven approaches presently dominate the thinking of the scientific community\*\*:

1. The biological concept of health (morbidity and mortality, disease as a disturbance of equilibrium, and genetic and environmental theories of disease).
2. The psychological concept of health (perceived health and illness, perceived deviance).
3. The social concept of health (disability within the context of the socioeconomic environment).

---

\*I would like to thank Loretta Hervey for her editorial assistance.

\*\*The first five concepts were summarized by P. Purola in a paper delivered at the International Workshop on Health Policy within the Framework of Societal Policy, Vienna, Austria, January 1977.

4. The behavioral concept of health (sick rate, sick leaves, propensity for seeking care, risk-taking behavior, i.e., smoking).
5. The economic concept of health (loss of income, cost of care, loss of productivity, social costs, etc.).
6. The managerial approach to health (the optimum organization and distribution of care within the existing structure of the health care system).
7. The political concept of health (which groups of people influence the health care system and possible changes in the structure and range of health care).

One additional theory that has received attention during past years should also be considered:

8. The iatrogenic concept of disease (disease caused by medical care).

To properly interpret health care models, it is necessary to identify the concepts on which they are based. A recent review by the IIASA team [1], of existing models in this field concentrated on this question. We found that most models are based either on the biological or economic concepts of health. *Biological* models usually consider sex, age, and category of disease, while *economic* models focus most often on the problem of allocation of health care.

Other concepts of health are rarely used as a basis for model building. Variables such as the etiology of illness, working conditions, leisure time activities, education, income, and housing (in brief, socioeconomic status) have not yet been included in health care models. It appears that this is not only due to the prevailing view of medicine as a "hard" science, but also due to (1) lack of data, (2) lack of appropriate modeling methods and, perhaps (3) the belief that social conditions cannot be influenced in the short run.

During the past month, I have evaluated existing empirical evidence concerning the influence of socioeconomic variables on health status (as measured by morbidity and mortality). The results of nearly every study support the hypothesis that low social status is linked to poor health status in Western countries.

#### SOME EMPIRICAL RESULTS FOR AUSTRIA

I have attempted to test whether this relationship holds in Austria. Two types of data were analyzed--official mortality statistics and responses to a survey of a representative

sample of the Austrian population. The results of the analysis are presented in two parts: first, the influence of selected socioeconomic factors and medical supply indicators on mortality rates are evaluated; and second, survey data dealing with physical and psychological complaints, sick leaves, and hospital stays are analyzed according to the socioeconomic status of the respondents.

#### Socioeconomic Status and Mortality Rates

This part of the analysis focused on the correlation between mortality rates and selected socioeconomic indicators (nationality, religion, education, type of employment, etc.). Mortality data were stratified by sex, age (19 age groups), and province\*. Correlation coefficients were computed at 1 percent, 5 percent, and 10 percent levels of significance.

Table 1 shows the correlation between male mortality rates by age group and selected socioeconomic indicators for the years 1969-1973 in Austria. Note the high correlation between infant mortality rates and parental employment in the mining industry (5 percent significance). High mortality is also associated with provinces in which a large percentage of the population works in agriculture and forestry. It is not surprising that mortality rates are also high among the self-employed, an occupational category consisting largely of farmers. Other occupational categories subject to high mortality rates include construction workers and skilled blue-collar workers. As may be expected, correlations between mortality rates and indicators of socioeconomic status are quite weak for the under-15 age groups.

#### Gross Regional Product per Capita and Mortality

Data in Table 2 show the association between mortality rates and the gross regional product per capita for 11 economic sectors in Austria. The only strong relationship, measured in terms of elasticities, is found between the mortality rate and the gross regional product per capita in the agriculture and forestry sector. The term "elasticity" denotes the factor of change in the dependent variable associated with a unit change in the independent (economic) variable. There is little difference in the findings for male and female employees in the various economic sectors.

---

\*Niederösterreich, Oberösterreich, Burgenland, Salzburg, Kärnten, Steiermark, Tirol, and Vorarlberg. Vienna was excluded because the health of its population is affected by special factors, such as environmental pollution.

Table 1. Correlation matrix: male mortality by age groups (1969 to 1973) and socioeconomic indicators, Austria (Vienna excluded), 1971.

Socioeconomic indicators	Age groups									
	0-1	1-5	5-10	10-15	15-20	20-25	25-30	30-35	35-40	
<u>Percentage of population in each category</u>										
Working population	01			-						
Agriculture and forestry	02				+++	++	+++	+	++	
Energy and water	03				--	-	---	-	--	
Mining	04	++				++				
Industry and manufacturing trade	05	++			--					
Construction	06			--	++		++		+	
Trade and stocks	07			++		-	---	--	-	
Hotels and restaurants	08	-					-	-		
Traffic and communication	09			++			--	-	-	
Banking and insurance	10				-	--	---	--	--	
Other services	11	--	+							
Unknown	12	-								
Self-employed	13				+++		++		++	
Employed by self-employed family member	14	--			++		+		+	
Total employed	15	++			---	-	--		-	
White-collar workers	16			+	--	-	---	--	--	
Skilled workers	17				++	+	++	++	+++	
Other workers	18	+		---			+	+		
University education	19			++			---	--	--	
High school education	20			++			--	--	-	
Medical education (including trade school)	21				--	-	-			
Apprentice education	22		--	+		+				
Other education (including primary)	23			---			++			
Retired	24		--		++	+++	+	+	++	
Unknown profession	25	--	+						-	
Levels of significance:	+++	---	1 percent							
	++	--	5 percent							
	+	-	10 percent							



40-45	45-50	50-55	55-60	60-65	65-70	70-75	75-80	80-85	85+	Average for all age groups
	+	++		++	+			+		
+++	++	++	+++	+++	+++	+++	+++	++	+	+++
---	--	--	---	---	---	---	---	---	---	---
++	++	++	+	++	+		++			
--	---	--	---	--	---	--	---	--	--	--
-	--	--	--	--	---	--	--	---	---	--
--	---	---	--	--	---	-	--	---	--	
---	--	--	---	--	---	---	---	--	--	---
		-			-			-	--	
	-	-		-						
++	++	++	++	+++	++	+	++	+		++
+			++	+	+	+	+			++
-			--	-		-	-			--
---	---	---	---	---	---	---	---	--	--	---
+++	+++	+++	+++	+++	+++	+++	+++	+++	++	+++
+	++	++	+	+	++		++	+	++	
---	---	---	--	--	---	--	---	--	--	-
--	--	---	--	--	---	-	--	--	--	-
			--	--	--	---	--		-	--
										+
	+	++	+	+	+			+		
+			++	++	+	+++	++	+	++	+++
-	--	--		-	-					

Table 2. Mortality rates (1969-1973) and gross regional product per capita, Austria (Vienna excluded), 1971.

Economic sector	Elasticities	
	Male	Female
Agriculture and forestry	+++ .32	+++ .36
Industry	-.07	-.05
Manufacturing trade	--- -.45	-- -.48
Construction	--- -.43	-- -.48
Electricity, gas, water	--- -.28	-- -.31
Traffic	-- -.35	- -.37
Trade	- -.24	- -.26
Banking	--- -.38	--- -.45
Housing	- -.48	- -.55
Public services	-.52	-.59
Other services	-- -.20	-- -.22
Total gross product per capita	-- -.54	- -.57

Levels of significance:

+++ , ---      1 percent  
 ++ , --        5 percent  
 + , -          10 percent

#### Indicators of Medical Supply and Mortality

The analysis of the influence of medical supply (as measured by density of physicians and availability of beds) on mortality rates did not provide conclusive results. As Table 3 shows, the density of general practitioners and of total physicians was not associated significantly with mortality rates. The high elasticity between mortality and density of dentists should be interpreted as an example of ecological fallacy: death rates are lower in wealthy regions and dentists are most likely to settle in such regions.

#### Nutrition and Mortality

An investigation of the possible connection between nutrition and mortality rates yielded the most significant results (Table 4). Elasticities greater than two were computed for the amount of money spent for food and mortality rates. When the food budget was disaggregated by type of food purchased, the following correlations were found: purchase of eggs, milk, fruit, nuts, vegetables, juice, tea, coffee, and prepared food is linked to reduced mortality rates; purchase of meat (in Austria mostly pork), bread, spices, wine, and mineral water seem to raise morbidity rates significantly.

Table 5 shows significant cross-correlations between different types of food consumption, as measured by the percentage

Table 3. Mortality rates (1969-1973) and medical supply in Austria (Vienna excluded), 1971.

Medical supply index	Elasticities	
	Male	Female
Density of GPs	.00	.07
Density of specialists	- .25	-.28
Density of dentists	-- -.31	-- -.34
Density of MDs in training	-.09	-.09
Density of all MDs	-.27	-.28
Beds actually available	.11	.14
Density of beds	-.14	-.14

Table 4. Mortality rates (1969-1973) and nutrition in Austria, expenditures, 1973.

	Elasticities	
	Male	Female
1 Food budget in Austrian schillings per month	--- -2.15	--- -2.43
Percentage spent for:		
2 Meat, meat products	+++ 2.03	++ 2.13
3 Fish	.66	.98
4 Eggs	--- -3.11	-- -3.40
5 Milk	--- -.91	--- -1.03
6 Fat	++ .38	.38
7 Bread	.98	1.02
8 Fruit	-- -.93	-- -.96
9 Nuts	-- -.63	- -.80
10 Vegetables	-- -1.12	- -1.17
11 Potatoes	-.30	-.37
12 Spices	1.32	1.17
13 Beverages	+ 1.11	1.18
14 Beer	-.43	-.60
15 Wine	+ .37	+ .40
16 Brandy	-.41	-.62
17 Other alcoholic beverages	.10	.12
18 Juice (fruit, vegetable)	-- -.67	- -.70
19 Mineral water	++ .26	++ .29
20 Other nonalcoholic beverages	.13	.18
21 Tea, coffee	-- -.84	-- -.94
22 Prepared food	-- -.90	-- -.90
23 Eating out	.00	.14

Levels of significance:

+++ , --- 1 percent  
 ++ , -- 5 percent  
 + , - 10 percent

Table 5. Correlation matrix: percentage of expenditures for food by types of food\*, Austria, 1973.

	1	2	3	4	5	6	7	8	9	10	11	12	13	14	15	16	17	18	19	20	21	22	23	
1																								
2	---																							
3																								
4	+++	---																						
5	+++	---	+++																					
6	--	+++	--	---																				
7	-	+++	-	+++	---																			
8	+++	---	+++	++	---	---																		
9	++	---	---	+	+	+	+																	
10	++	---	+++	++	++	--	-	+++																
11		+++		--		++	++	---	---															
12	-	+	-	---	+	+	-	-																
13	-		-	---	+	+	-	-																
14			-	-	---	+	-	-																
15	--	++	-	--	+++	+++	---	---	---															
16																								
17																								
18	+++	---	++	++	--	--	+++	+++	+++	---	---	---	---	---	---	---	---	---	---	---	---	---	---	---
19	--	+++	--	---	---	++	+++	---	--	+	+	+	+	+	+	+	+	+	+	+	+	+	+	
20																								
21	++	---	++	+++	-	--	+	+	+	+	+	+	+	+	+	+	+	+	+	+	+	+	+	
22	++	---	++	++	++	--	++	++	+++	+++	---	---	---	---	---	---	---	---	---	---	---	---	---	
23			+			-	---	---	---	---	---	---	---	---	---	---	---	---	---	---	---	---	---	

Levels of significance:

- +++ , --- 1 percent
- ++ , -- 5 percent
- + , - 10 percent

\*See Table 4 for definition of the 23 categories.

of the food budget spent on each of the 22 categories of food. The data indicate that there are significant intercorrelations among "healthy" types of food, as discussed above, as well as among "unhealthy" foods. Moreover, there are always significant negative correlations between foods from the two groups. The percentage of expenditures for "healthy" foods is positively correlated with overall food expenditures; moreover, the percentage of expenditures for "unhealthy" foods is negatively correlated with overall food expenditures.

#### Socioeconomic Status and Morbidity

In 1973, a representative sample of 90,000 Austrian citizens participated in a health survey. Questionnaires were used to collect data on such health status variables as physical and psychological complaints, illnesses, doctor visits, and hospital visits.\*

Cases of illness reported by survey respondents were grouped into 12 diagnostic categories. They are:

- A. Influenza
- B. Chronic bronchitis, asthma, etc.
- C. Cardiovascular diseases, hypertensive diseases
- D. Heart attack
- E. Diseases of the digestive system
- F. Neuralgic diseases
- G. Diseases of the spine and joints
- H. Eye diseases
- I. Ear diseases
- J. Skin diseases
- K. Fractures, other injuries
- L. All other causes

Socioeconomic status was measured by type of employment:

---

\*I am indebted to the Austrian Central Statistical Office for the special processing of the questionnaires which permitted me to analyze the data according to the socioeconomic status of the respondents.

1. Apprentice, blue-collar
2. Apprentice, white-collar
3. Unskilled, blue-collar
4. Semiskilled, blue-collar
5. Skilled, blue-collar
6. Assistant (unskilled), white-collar
7. Unqualified, white-collar
8. Semiqualfified, white-collar
9. Qualified, white-collar
10. Qualified managerial, white-collar
11. Self-employed
12. Employed by head of family

Three of the employment categories represent blue-collar workers; five, white-collar workers; two, the self-employed and their relatives; and two, apprentice status. Questionnaire responses were analyzed according to the age and sex of the respondents, as well as by diagnostic group and socioeconomic category.

In Tables 6 and 7, the cases of illness, by diagnostic group, reported by respondents in each socioeconomic category are compared to the responses given by the members of the other socioeconomic categories. A plus sign (+) for socioeconomic category  $i$  in row  $j$  and column  $k$  means that the frequency of occurrence of cases of illness of diagnostic group  $k$  is higher for category  $j$  than for category  $i$ , to a 10 percent level of significance. By constructing a health status index (HSI) where

$$\text{HSI for category } i = \frac{\text{number of + signs in matrix for category } i}{\text{number of + and - signs in matrix for category } i} ,$$

it is possible to obtain a relative measure of reported health status for each socioeconomic category. The HSI corrects for differences in sample size to a certain degree. Its range is  $0 \leq \text{HSI} \leq 1$ .

The HSI can be used to rank the socioeconomic categories according to their relative health status. As shown in Table 8, the self-employed seem to enjoy the best relative position with regard to health status, followed by white-collar workers. Blue-collar workers generally rank lowest. Qualified, managerial

Table 6. Cases of reported illness by employment category (male).

Socio-economic category (j)	1. Apprentice, blue-collar (HSI* = .71) (i)													2. Apprentice, white-collar (HSI = .20)												
	Diagnostic group (k) →																									
	A	B	C	D	E	F	G	H	I	J	K	L	A	B	C	D	E	F	G	H	I	J	K	L		
x1													1	-												
2	+							+					x2													
3	-	+	+		+	+	+					-	3	-										-		
4	-	+	+		+	+	+						4	-			+									
5	+		+		+	+	+					-	+	5	-										-	
6	+	+	+	+								-	6		+									-		
7								+				-	7											-		
8		+	+	+	+	+						-	+	8	-	+									-	
9		+				+	-			-	-	+	9	-										-		
10		+	+			+	+					-	+	10	-		+								-	
11	-		+		+	+	+			-	-	-		11	-	-	+								-	
12	-						+					-		12	-	-									-	
	3. Unskilled, blue-collar (HSI = .38)													4. Semiskilled, blue-collar (HSI = .13)												
	A	B	C	D	E	F	G	H	I	J	K	L	A	B	C	D	E	F	G	H	I	J	K	L		
1	+	-	-		-	-	-					+	1	+	-	-		-	-	-						
2	+											+	2	+				-		-						
x3													3	-				-						-		
4	+			+								+	+	x4												
5	+	-											5	-				-		-				-		
6	+				+							-	-	6				+			-			-		
7													-	7										-		
8	+		+	-						-	-	-	+	8					-		-				-	
9	+	-		+	-					-	-	-	+	9	+	-			-		-				-	
10	+		+	-								-	+	10	+			+	-						-	
11			+	-								-	-	11	-				-		-				-	
12						-		-				-		12	-				-		-				-	
	5. Skilled, blue-collar (HSI = .26)													6. Assistant (unskilled), white-collar (HSI = .32)												
	A	B	C	D	E	F	G	H	I	J	K	L	A	B	C	D	E	F	G	H	I	J	K	L		
1		-				-	-	-				+	-	1	-	-	-	-							+	
2		+										+		2		-									+	
3		-	+											3	-				-		+		+	+		
4		+		+	+							+		4					-		+		+	+		
x5														5					-		+		+	+		
6				+								-		x6												
7													-	7												
8				+									-	8											-	
9						-							-	9	-				-						-	
10				+	-								-	10											-	
11	-					-							-	11	-				-						-	
12	-					-							-	12	-				-						-	

\*Health status index





Table 7. Cases of reported illness by employment category (female).

		1. Apprentice, blue-collar (HSI* = .95)												2. Apprentice, white-collar (HSI = .60)											
		Diagnostic group (k) →																							
		A	B	C	D	E	F	G	H	I	J	K	L	A	B	C	D	E	F	G	H	I	J	K	L
Socio- economic category (j) ↓	x1																								
	2	+											+												
	3		+									+	+												
	4											+	+												
	5											+													
	6																								
	7	+										+													
	8											+													
	9	+										+													
	10	+		+								+													
	11											+													
	12			+								+	-												
		3. Unskilled, blue-collar (HSI = .26)												4. Semiskilled, blue-collar (HSI = .24)											
		A B C D E F G H I J K L												A B C D E F G H I J K L											
	1				-			-	-											-	-				
	2	+			-			-	-				+							-	-				
	x3																								
	4				-								+												
	5				-																-				
	6	+			-			-	-											-	-				
	7	+			-			-	-											-	-				
	8	+			-			-	-											-	-				
	9	+			-			-	-											-	-				
	10	+								+										+					
	11				-			-	-											-	-				
	12				-			-	-											-	-				
		5. Skilled, blue-collar (HSI = .45)												6. Assistant (unskilled), white-collar (HSI = .75)											
		A B C D E F G H I J K L												A B C D E F G H I J K L											
	1											-													
	2	+			-			-				+								-					
	3				+			+												+	+				
	4							+												+	+				
	x5																				+	+			
	6											-	-												
	7	+										-													
	8	+										-								+					
	9	+																							
	10	+			+															+					
	11											-	-							-	+				
	12											-								+					

\*Health status index



Table 8. Order of relative health status as measured by the health status index, by socioeconomic category and illness group, Austria, 1973 (apprentices excluded).

Health status	Male	Female
Best ↑ ↓ Worst	Employed by head of family	Self-employed
	Self-employed	Employed by head of family
	Qualified, white-collar	Assistant, white-collar
	Unqualified, white-collar	Qualified, white-collar
	Semiqualfied, white-collar	Semiqualfied, white-collar
	Qualified managerial, white-collar	Unqualified, white-collar
	Unskilled, blue-collar	Skilled, blue-collar
	Assistant (unskilled), white-collar	Unskilled, blue-collar
		Semiskilled, blue-collar
		Qualified managerial, white-collar
	Semiskilled, blue-collar	Qualified managerial, white-collar

white-collar female workers deviate from this pattern, for their relative health status is lowest among female workers. Perhaps this is due to the stress of competing with men on the job in addition to fulfilling the usual obligations (kitchen, children, household). This could also be a reason why unqualified, semi-qualified, and qualified female white-collar workers have lower HSI values than their male colleagues. These results hold for both reported frequency of occurrence of illness and reported duration of illness.

The high HSI value for the self-employed (mostly farmers) relative to other workers is not easy to interpret. As in every investigation of this type, it is difficult to judge whether health status is due to good resistance to illness or favorable environmental conditions, or whether it results from reluctance to report illness or a low sensitivity toward perceiving illness. The fact that other Austrian studies have found that female farmers in their thirties have mortality rates about three times higher than the Austrian average indicates that the high HSI scores do not necessarily correspond to good health.

Table 6 indicates that semiskilled blue-collar workers have the lowest HSI (.13). For each diagnostic group the signs are negative, with the exception of influenza and heart attack. The two highest categories of white-collar workers and apprentices reported more influenza. This may result from a greater sensitivity toward illness among workers in these socioeconomic categories.

Noteworthy is the finding that the highest rates of heart attacks among males were reported by unskilled assistant white-collar (stratum 6) and managerial white-collar workers (stratum 10). The high rates among low-status white-collar males challenge the popular belief that the "manager class" has the highest risk of heart attack.

Looking specifically at women, socioeconomic differences in reported rates of heart attack are not highly visible. Semiqualfied white-collar workers reported higher rates than unqualified white-collar workers. There were no significant differences between the rates for other strata.

Numerous observations could be made about the reported rates of illness by employment category as presented in Tables 6 and 7. However, space limitations permit only one additional comment: male apprentices have higher injury rates than all other strata, with the exception of semiskilled blue-collar males. As discussed above, these groups also scored very low on the HSI. These results indicate the urgent need for preventive health programs directed at these workers.

Another analytical procedure applied to the morbidity data was the construction of "similarity matrices" for the 12 socioeconomic groups (Table 9). Similarity matrices are based on a comparison of reported morbidity rates by age group, and the elements of the matrix show the number of significant differences in reported illness between two socioeconomic groups for each of the five age groups. In Table 9, using a range of 0 to 5, a 0 in the i-th row and j-th column indicates that there is no significant difference between the percentage of workers in each socioeconomic group who do not report severe illness in any age group. A 5 in the i-th row and j-th column indicates a significant difference for each age group of the two socioeconomic categories. In this manner, each pair of economic categories is associated with a given degree of similarity (DOS).

Analysis of the matrices points out clusters of socioeconomic categories with similar patterns of reported illness (Figure 1). There is a high degree of similarity (DOS = 0) among all male blue-collar workers (unskilled, semiskilled, and skilled), as well as among unskilled and semiqualfied male white-collar workers and unqualified and semiqualfied male white-collar workers. Qualified male white-collar workers and qualified managerial white-collar workers also show a similarity in reporting severe illness. There is a high degree of similarity (DOS = 0) among all female white-collar workers. Other pairs of socioeconomic categories that show similarity (DOS = 0) in rates of reported severe illness are managerial white-collar women and semiqualfied blue-collar women, semiqualfied white-collar women and skilled blue-collar women, and finally skilled female blue-collar workers and semiskilled blue-collar women.

Table 9. Percentage reporting severe illness, Austria, 1973. Degree of similarity (DOS) between socioeconomic groups by age (apprentices excluded).

Male												Female											
1	2	3	4	5	6	7	8	9	10	11	12	1	2	3	4	5	6	7	8	9	10	11	12
1												1											
2												2											
3		0	0	0	1	2	2	2	2	4	3	3		0	2	1	2	2	2	1	1	5	5
4		0	0	0	1	5	3	5	3	5	4	4		2	0	0	1	3	1	2	0	3	3
5		0	0	0	1	3	2	3	3	4	4	5		1	0	0	1	1	0	1	1	2	2
6		1	1	1	0	1	0	1	1	2	2	6		2	1	1	0	1	1	0	0	2	1
7		2	5	3	1	0	0	2	1	3	2	7		2	2	1	1	0	0	0	0	3	4
8		2	3	2	0	0	0	1	2	3	3	8		2	1	0	1	0	0	1	1	2	3
9		2	5	3	1	2	1	0	0	3	2	9		1	2	1	0	0	1	0	0	3	1
10		2	3	3	1	1	2	0	0	3	3	10.		1	0	1	0	0	1	0	0	3	3
11		4	5	4	2	3	3	3	3	0	2	11		5	3	2	2	3	2	3	3	0	1
12		3	4	4	2	2	3	2	3	2	0	12		5	3	2	1	4	3	1	3	1	0

CONCLUSIONS

Three extensions of health care modeling are suggested here to take into account the influence of socioeconomic factors in health care. Of course, these proposals are not exhaustive, and they may have to be modified to meet the specific interests of the organization engaged in modeling. However, the incorporation of these approaches into health care models would make the models more realistic and more useful for application to health care management problems.

The Social Strata Approach

The first approach involves disaggregating mortality/morbidity indicators by social strata. This would make it possible to incorporate the empirical parameters of the performance of different social groups into an overall health status indicator. The methodological approach discussed by Petrovsky et al. (see "Problem-Oriented Global Modeling: Developing a Health Care-Oriented Simulation Model") could be used if one takes into account the social strata instead of, or in addition to, age groups. The dynamics of this system must be handled by a social mobility model, which in turn should be linked to an economic and demographic model as shown in Figure 2.

The Behavioral Approach

There is much evidence that consumption patterns of health care depend on socioeconomic variables. For instance, in the model presented by Kaihara (see "Analyzing Demands for Medical Care by Computer Simulation: An Example of Application of the

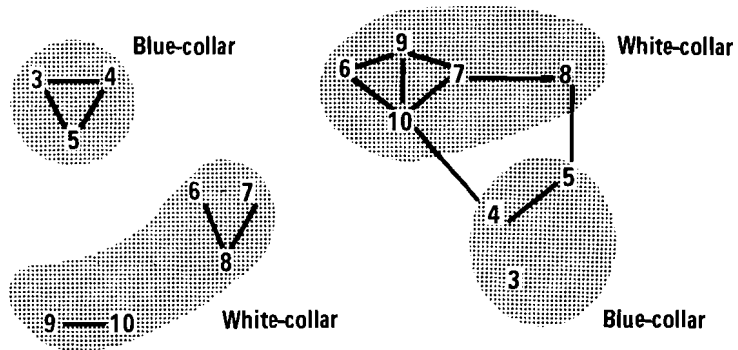

Figure 1. Clusters of socioeconomic categories with similar patterns of reported illness.

Health Care System Model"), the "rate of awareness" of illness among the public depended on socioeconomic status. Such relationships could be incorporated into the health care model through the endogenization of exogenous variables. It would also be possible to model changes in health behavior that result from implementation of special programs, such as Medicare and Medicaid.

#### The Political Approach

The political factors that influence health care could be considered by adding "soft" variables to the health care model, but would just be necessary to identify those groups of people materially interested in the health care system. The influence of these groups on political decisions could be indicated by variables that are incorporated into the health care, socioeconomic,

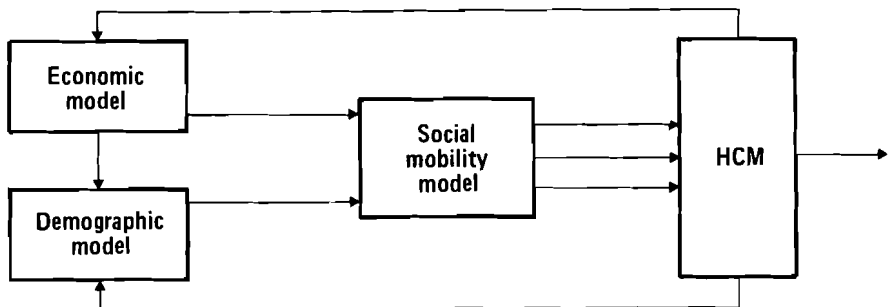

Figure 2. The incorporation of the social strata approach into health care models (HCM).

demographic, etc., models. Using this approach, a complex model structure would be necessary to handle the problem under investigation in sufficient detail. It would be desirable to have an interactive model of the political consensus and/or decision processes so that the outcome of these processes could influence variables in the health care system.

REFERENCE

- [1] Fleissner, P., and A. Klementiev, *Health Care System Models: A Review*, RM-77-49, International Institute for Applied Systems Analysis, Laxenburg, Austria, 1977.

MEDICAL CARE DEMAND MODEL FOR ESTIMATING  
THE COST OF MEDICAL CARE

K. Atsumi, I. Fujimasa, and S. Kaihara

INTRODUCTION

The cost of medical care depends on the demand for that care, and every country is experiencing a gap between demand and supply.

On the one hand, medical demand can be basically defined as the number of patients, including so-called latent patients. By using the morbidity model we have developed [1,2], it is possible to estimate the number of patients in each disease category.

On the other hand, a country's medical supply is strongly influenced by that country's gross national product or gross domestic product and its medical structure. Medical care expenditures per patient do not vary widely among the various developed countries where the level of medical techniques and technologies are similar. However any differences can usually be attributed to differences between manpower costs and lengths of hospital stay.

In analyzing medical care problems, the various diseases should be divided into two groups--biologically generated diseases and socioeconomically influenced diseases. The reason for this is that medical problems apparently differ among developed countries due to their different policies for the socioeconomically influenced diseases. Therefore, from the viewpoint of designing the model, various diseases are classified into the same two categories--those for which it is relatively easy to estimate the number of the patients from the population structure and those for which it is rather difficult to do so. Degenerative diseases such as heart disease, cancer, etc., and acute infectious diseases belong in the former category, that is, diseases thought to result from biological causes. Mental disease, dental problems, accidents, etc. belong in the latter category, that is, they are related to socioeconomic or sociocultural conditions.

Presently, almost all medical care expenditures are spent on the degenerative diseases and acute infectious diseases. Therefore, if the number of patients in this category could be estimated by the universal morbidity model, it would also be possible to estimate the actual national medical care cost. In developed countries, medical care expenditures depend on medical structures and the economical use of manpower and facilities and on policies



for prevention, treatment, and rehabilitation. Thus, from the viewpoint of national health planners, it would be useful to obtain an estimate of the numbers of patients and of medical care costs and to compare the costs with actual medical expenditures both at the national and international level.

#### ESTIMATING THE ANNUAL COST OF IN-PATIENT CARE PER CAPITA

Figure 1 shows a flowchart of our demand model for estimating medical care costs. The area within the solid line uses Japan's statistics, and the area within the dotted line uses statistics of other countries.

We have divided the various diseases into the 18 groups shown in Table 1.

Table 2 shows the population structure of the developed countries which is based on statistics of the World Health Organization. For an exact estimate, it would be necessary to use one-year age strata. However, to save calculation time, we used four strata--0-14, 15-34, 35-64, and 65-85.

From the data on population and from prevalence rates of diseases calculated from [3], we calculated the number of sick and the total sick per day for Japan, and for the USA, and England and Wales (Table 3). Then, using the ratio of in-patients and out-patients for Japan shown in Table 4, we divided the total number of patients into two groups--in-patient and out-patient visits per day--for all countries (Table 5).

By multiplying numbers of the annual bed-days per capita by the hospital care cost rate (sample values from the Japanese in-patient cost survey), the annual in-patient care cost per capita of a target country can be estimated on a standardized country base (Table 6).\* And, using the same procedure, it is possible to estimate the annual out-patient care cost (Table 6).

#### ESTIMATING THE BED UTILITY AND COST RATIOS

It is also possible to estimate the annual in-patient and out-patient care cost of each target country through medical care cost surveys.

Table 6 shows in-patient and out-patient costs in Japan, the USA, and England and Wales. However, there is a difference in lengths of hospital stay between Japan and the USA and England

---

\*This standardization was obtained from a Japanese hospital survey. But, if it can be obtained, the international mean value of patient statistics (e.g., bed-days per capita and length of hospital stay) should be used in the model.

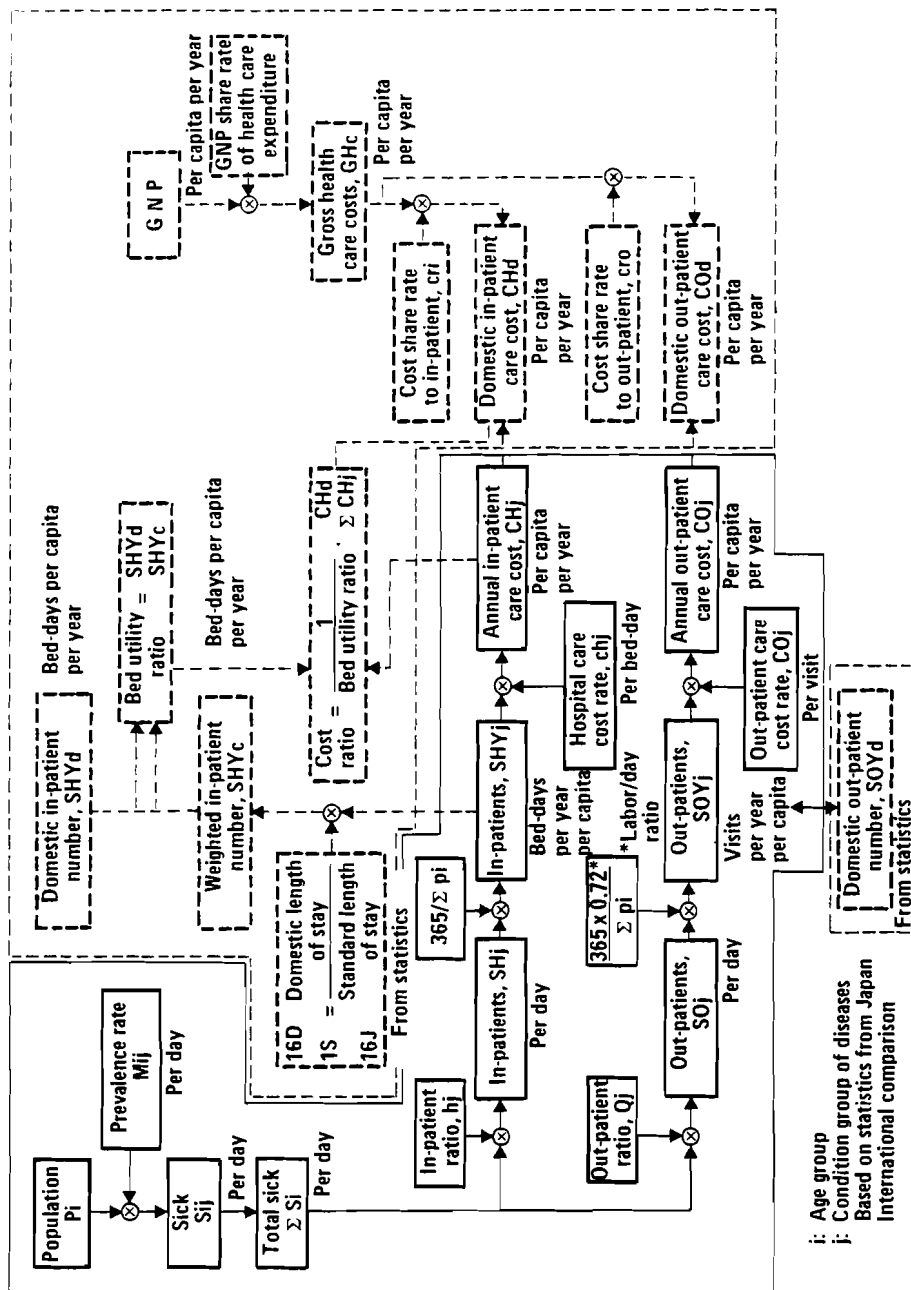

Figure 1. Flow chart of demand model to estimate medical care cost.

Table 1. Disease categories.

	ICD* List A	ICD List B	XVII English ICD Listings
<b>A. Degenerative diseases</b>			
1. Neoplasms	a45-61	b19, 20	II
2. Cardiovascular, cerebrovascular	a80-85	b25-30, 46c	VII
3. Other systemic	a62-68	b23, 24	III + IV
4. Nephritis and nephrosis	a105-108	b38a	X
5. Urogenital system	a109-111	b38b, 39	X
6. Ill-defined conditions	a136-137	b45a, b45b, 46c	XVI
7. Musculoskeletal and connective tissue	a121-125		XIII
8. Asthma and chronic bronchitis	a93	b33b, b33c	VIII
<b>B. Acute or subacute curable diseases</b>			
9. Infective and parasitic	a1-44, 72, 82-92, 94-96, 99	b1-18, 24, 31-33a, 46d, 46e	I, VIII, IX
10. Neurosensory	a73-79		VI
11. Peripheral circulatory	a86-88		VII
12. Digestive system	a98, 100-104	b34-37	IX
13. Skin and subcutaneous	a119, 120		XII
14. Teeth and supporting system	a97		IX
15. Mental disorders	a69-71	b46a	V
16. Injuries and disorders from other causes	ael38-150	be47-50	XVII
17. Pregnancy, childbirth, and puerperium	an138-150	b40, 41	
<b>C. Congenital abnormality</b>			
18. Congenital abnormality and perinatal morbidity	a120-135	b42-44	XIV, XV

\*International Classification of Diseases.

Table 2. Population structure of developed countries, 1974 (100,000s).

Source: World Health Organization

Regions and countries	All ages	0-14	15-34	35-64	65-85
Free market total	7,028.2	1,748.5	2,166.5	2,341.1	769.7
America total	2,338.4	607.2	765.6	728.6	237.0
1. USA	2,113.9	546.2	688.9	660.7	218.2
2. Canada	224.5	61.0	76.7	67.9	18.8
Asia total	1,134.2	279.6	381.1	385.5	87.1
3. Japan	1,100.5	268.5	370.1	377.3	84.6
4. Israel	33.7	11.1	11.0	9.2	2.5
Oceania total	162.3	46.7	51.5	50.4	13.7
5. Australia	131.3	37.3	41.6	41.4	11.0
6. New Zealand	31.0	9.4	9.9	9.0	2.7
Europe total	7,169.6	1,784.5*	2,138.9*	2,533.8*	689.9*
EC total	2,566.2	605.7	732.5	890.6	337.7
7. Belgium	97.6	22.3	27.4	34.4	13.5
8. Denmark	50.2	11.5	15.2	17.1	6.5
9. France	517.0	122.7	151.5	172.9	70.0
10. GFR	619.8	138.7	174.2	220.9	86.0
11. Ireland	30.9	9.6	8.8	9.1	3.4
12. Italy	551.9	134.2	154.5	197.9	65.1
13. Luxembourg	3.6	0.8	1.1	1.3	0.5
14. Netherlands	135.5	35.1	43.4	42.6	14.4
15. UK--Eng. W.	492.2	113.5	137.2	171.9	69.7
16. UK--N. Ireland	15.4	4.5	4.5	4.8	1.7
17. UK--Scotland	52.1	12.8	14.7	17.7	6.9
Free trade union	397.1	92.9	115.9	135.1	50.4
18. Austria	74.9	16.8	21.1	24.9	11.1
19. Finland	46.8	10.6	15.7	15.8	4.7
20. Iceland	2.2	0.7	0.7	0.6	0.2
21. Norway	40.0	9.6	9.9	13.3	5.4
22. Portugal	87.8	23.9	25.2	29.7	9.0
23. Sweden	81.6	16.9	23.6	29.0	12.1
24. Switzerland	63.8	14.4	19.7	21.8	7.9
25. Spain	340.4	94.8	95.5	117.1	33.0
26. Greece	89.6	21.6	24.4	32.8	10.8
Central planning countries	3,776.3	969.5*	1,170.6*	1,358.2*	258.0*
Comecon total	3,550.4	914.5	1,103.6	1,288.1	240.6
27. USSR	2,497.5	669.7	776.1	925.4	122.8
28. Bulgaria	86.8	19.3	25.6	32.7	9.2
29. Czechoslovakia	145.6	33.2	45.9	49.4	17.1
30. GDR	168.5	36.5	47.1	57.5	27.4
31. Hungary	104.8	21.0	32.4	38.3	13.0
32. Poland	336.9	82.0	113.3	110.3	31.3
33. Romania	210.3	52.8	63.2	74.5	19.8
34. Albania	16.3				
35. Yugoslavia	209.6	55.0	67.0	70.1	17.4
Developed country total	10,804.5	2,718.0*	3,343.1*	3,699.3*	1,027.7*

\*Excludes Albania.

Table 3. Total sick per day for Japan, the USA, and England and Wales per disease category (1000s).

Disease category (j)	Japan	USA	England and Wales
1	134.0	265.5	72.2
2	2,882.1	6,454.9	1,931.4
3	623.2	1,216.3	320.4
4	94.0	184.9	44.1
5	361.1	688.8	170.0
6	125.8	244.9	60.6
7	738.9	1,665.3	685.6
8	248.4	510.6	134.2
9	2,591.6	5,126.3	1,197.0
10	1,855.1	3,744.1	942.4
11	255.0	534.7	150.7
12	922.8	1,778.9	458.1
13	788.8	1,539.6	364.3
14	2,489.6	4,704.8	1,076.5
15	412.5	769.5	190.5
16	664.3	1,285.2	306.8
17	124.2	437.9	47.2
18	118.5	228.0	51.2
Total ( $\sum S_j$ )	15,429.9	31,380.2	8,203.2

Table 4. In-patients and out-patients per 100,000 population per day, classified by 18 disease categories and their costs per day.

Source: Japan's 1975 "Patient Survey Statistics" and "Hospital Survey Statistics"

	(1)	(2)	(3)	(4)	(5)	(6)	(7)	(8)	(11)	(12)
Disease category (j)	Hospital-ized (per 100,000)	Old out-patient (per 100,000)	New out-patient (per 100,000)	Total out-patient (per 100,000)	Hospital-ization ratio (hj), (percent)	Out-patient* (per 100,000)	Out-patient** visit ratio (qj) (percent)	In-patient price (JP), 1975 (Chj) (yen/day)	Out-patient price (JP), 1975 (CQj) (yen/visit)	
1	57	63	5	68	0.456	38	0.544	12,000	3,600	
2	119	2,654	27	2,681	0.043	659	0.957	7,000	2,400	
3	25	520	15	535	0.045	145	0.955	7,500	2,050	
4	16	65	3	68	0.190	45	0.810	14,300	8,000	
5	17	173	38	211	0.075	113	0.925	8,000	2,700	
6	8	81	13	94	0.078	50	0.922	10,600	1,850	
7	38	871	45	916	0.040	441	0.960	6,500	1,650	
8	11	195	6	201	0.052	67	0.948	8,000	1,700	
9	114	2,328	418	2,746	0.040	1,476	0.960	5,500	1,800	
10	51	1,543	103	1,646	0.030	774	0.970	6,200	1,450	
11	11	416	8	424	0.025	107	0.975	6,500	1,800	
12	96	630	34	664	0.126	308	0.874	7,400	2,300	
13	4	612	86	698	0.005	352	0.994	6,500	1,650	
14	0	2,328	165	2,493	0.000	916	1.000	--	2,300	
15	222	160	6	166	0.572	47	0.428	4,300	2,700	
16	81	343	69	412	0.164	314	0.836	6,000	1,800	
17	43	75	6	81	0.347	36	0.653	6,500	1,700	
18	13	36	4	40	0.245	24	0.755	7,300	1,600	

\* (6) = ((2)/mean visit interval) + (3).

\*\* (8) = (7) × (6) / (4).

Table 5. Total number of in-patient and out-patient visits per day for Japan, USA, and England and Wales (thousands per day).

Disease category (j)	In-patient visits (SH <sub>j</sub> )			Out-patient visits (SO <sub>j</sub> )		
	Japan	USA	England and Wales	Japan	USA	England and Wales
1	61.1	121.0	18.7	40.7	80.7	21.9
2	124.0	277.6	83.1	677.3	1,516.9	453.9
3	20.1	54.7	14.4	16.1	315.0	83.0
4	18.9	35.1	8.4	50.4	99.1	23.6
5	27.1	51.7	12.7	178.7	341.1	84.1
6	9.9	19.1	4.7	61.6	120.0	29.7
7	30.0	66.6	27.4	341.4	769.3	316.7
8	13.0	26.6	7.0	78.5	161.3	42.4
9	103.7	205.1	47.9	1,337.3	2,645.2	617.6
10	55.7	112.3	28.3	845.9	3,631.8	429.7
11	6.4	13.4	3.8	62.7	131.5	37.1
12	116.3	224.1	57.7	806.5	1,554.7	185.5
13	4.7	9.2	2.2	784.0	1,530.4	182.5
14	0	0	0	913.7	1,726.7	395.1
15	235.9	440.2	109.0	49.9	93.1	23.1
16	108.9	210.8	50.3	423.1	818.7	195.5
17	43.1	152.0	16.4	36.0	127.0	13.7
18	29.0	55.9	12.5	53.7	103.3	23.2
Total	1,007.8	2,075.4	518.7	6,757.5	15,765.8	3,158.3

Table 6. Annual in-patient and out-patient care cost per capita for Japan, USA, and England and Wales (million Yen per day).

Disease category (j)	In-patient care cost (CH <sub>j</sub> )			Out-patient care cost (CO <sub>j</sub> )		
	Japan	USA	England and Wales	Japan	USA	England and Wales
1	733.1	1,452.6	394.8	146.6	290.5	79.0
2	867.5	1,942.9	581.3	1,625.5	3,640.6	1,089.3
3	156.3	410.5	108.1	33.1	645.8	170.1
4	255.5	502.4	119.9	403.2	793.0	189.2
5	216.7	413.3	102.0	482.6	920.6	227.2
6	104.0	202.5	50.1	114.0	222.0	54.9
7	192.1	433.0	178.2	563.2	1,269.4	522.6
8	103.3	212.4	55.8	133.4	274.3	72.1
9	570.1	1,127.8	263.3	2,407.1	4,761.3	1,111.8
10	345.0	696.4	175.3	1,226.6	5,266.1	623.1
11	41.4	86.9	24.5	112.9	236.8	66.7
12	860.4	1,658.6	427.1	1,855.0	3,575.9	426.7
13	30.8	60.0	14.2	1,293.7	2,525.1	301.1
14				2,101.5	3,971.3	908.7
15	1,014.6	1,892.7	468.6	1,347.6	251.4	62.2
16	653.6	1,264.7	301.9	7,616.4	1,473.7	351.8
17	280.2	987.7	106.4	612.5	215.9	23.3
18	211.9	407.7	91.5	858.8	165.2	37.1
Total	6,636.5	13,752.1	3,463.0	13,542.0	30,498.8	6,316.9



and Wales. Therefore, if we want to compare the real cost and the estimated cost of the other countries by Japan's standard, some indices should be introduced. The standard in-patient bed-days in Table 6 are obtained from the standard (Japan's statistics) length of stay. Therefore, the standard bed-days should be corrected by the ratio of the domestic length of stay and the standard length of stay. From this ratio and the annual number of bed-days per capita of the patients, the weighted in-patient number is calculated, which tells us how many patients can be handled in the standard country under the same length of stay of the target country.

Then, from the weighted in-patient number and the domestic in-patient number, which are easily attainable from the national statistics, we can calculate the bed utility ratio (which is the efficiency rate of in-patient care):

$$\text{Bed utility ratio} = \frac{\text{domestic in-patient number}}{\text{weighted in-patient number}}$$

Therefore, using these data, the cost ratio (per in-patient) can be calculated:

$$\text{Cost ratio} = \frac{1}{\text{bed utility ratio}} \times \frac{\text{domestic annual in-patient care cost}}{\text{(estimated) total annual in-patient care cost}}$$

## RESULTS

The medical care cost of in-patients and out-patients, the bed utility ratio, and the cost ratio were estimated for Japan, the USA and England and Wales, and are summarized and compared in Table 7.

The actual numbers of in-patient bed-days are 2500 in Japan, 1440 in the USA, and 2130 in England, while the numbers of in-patient bed-days estimated from Japan's statistics are 2540, 2280, and 3040, respectively.

The average length of hospital stays is 44.7 days, Japan; 9.5 days, USA; and 20.1 days, England and Wales. From these data, the ratios of domestic length of stay for the USA and England and Wales to Japan are 4.68 and 2.11, respectively.

From the ratio and the number of the estimated in-patients, the following weighted in-patient numbers were calculated: USA, 602; England and Wales, 1373. Therefore, the bed utility ratios were calculated as 2.37 for the USA and 1.55 for England and Wales. Finally, the cost ratios were calculated: Japan, 1.12; USA, 0.62; and England and Wales, 0.73.

Table 7. Comparative study of national health care demand and expenditure.

	Japan		USA		England		
	Computed 1974	Statistics 1975	Computed 1974	Statistics 1975	Computed 1974	Statistics 1975	
Population (millions)	110.0	103.5	211.4	204.9	49.2	46.5	
Demand (per 1000 people per year)							
In-patient (bed-days)	General and special	2,540 (*2,500)	2,500 (*1.00)	2,820 (*602)	1,440 (*2.39)	3,040 (*1,373)	2,130 (*1.55)
	Mental	780	880	760 (*590)	860 (*1.46)	800	1,470
Average length of stay	General		44.5		9.5		20.1
	Mental		336.2		261.2		---
Out-patient (visit days)	General and special	13,900	13,500	17,500	---	14,800	2,100
	Teeth and support system	2,400	2,700	2,100	---	1,060	---

Expenditure (per capita, per year)									
In-patient	Domestic currency	21,900 ¥	24,520 ¥					39.4 f	44.3 f
	\$	78.2	87.6 (**1.12)	84.7	125.4 (**0.62)			92.5	104.0 (**0.73)
Out-patient	Domestic	32,217 ¥	32,473 ¥					51.8 f	9.7 f
	\$	115.1	116.0	182.6	135.0			121.7	22.8
Teeth and support system	Domestic	4,997 ¥	5,474 ¥						
	\$	17.8	19.6	17.7	21.6				
Total health care expenditure	Domestic		6,478 bil. ¥						2,788 mil. f
	\$		23.14 bil. \$		71.57 bil. \$				6.55 bil. \$
	per cap.		223.5 \$		349.1 \$				117.0 \$
	% GNP		4.3 %		7.1 %				3.8 \$
		Excludes construction, research, and public health expenditures							Excludes research expenditure

\* Correction by average length of stay.

\*\* Bed utility ratio (Japan 1975 = 1.00).

\*\*\* Cost ratio (Japan 1974 = 1.00).

In comparison with the value of this cost ratio, the lower the number, the more efficient the cost-performance. These numbers show that the USA and England have more efficient cost/performance in medical care than Japan.

REFERENCES

- [1] Kaihara, S., I. Fujimasa, K. Atsumi, and A.A. Klementiev, *An Approach to Building a Universal Health Care Model: Morbidity Model of Degenerative Diseases*, RM-77-6, International Institute for Applied Systems Analysis, Laxenburg, Austria, 1977.
- [2] Fujimasa, I., S. Kaihara, and K. Atsumi., *A Morbidity Sub-model of Infectious Diseases*, RM-78-10, International Institute for Applied Systems Analysis, Laxenburg, Austria, 1978.
- [3] Health and Welfare Statistics Association, *Recent Trends in National Health Care*, Tokyo, 1975 (in Japanese).

THE HEALTH INDEX AS A CRITERION OF FUNCTION OF A BASIC  
MODEL OF THE HUMAN ENVIRONMENT

R. Miksl

At the 1975 IIASA Biomedical Conference held in Moscow, we presented a brief paper describing a basic model of the human environment [1]. The present paper presents the result obtained from testing the prognostic value of environmental factors affecting the health of human population. Human health is an output function in the human environment system and we have investigated the impact of environmental factors on the health index.

TEST SUBJECTS AND METHOD

We combined 28 ecological units in the region of Northern Moravia, Czechoslovakia, showing similar characteristic features--population, scenery relief, production--into the 13 ecologically equivalent areas shown in Table 1. In these, we classified environmental factors into six categories, category 1 being the best and category 6 the most adverse, respectively. We also obtained other factors such as profession distribution factors which indicate the percentage of population working in agriculture.

Two age groups of natives (22-year-olds, 1464; 52-year-olds, 857) within the 13 areas were selected for investigation of their health index.

Based on the scale defined by the World Health Organization, a health index was developed consisting of five categories: category 1 - full health to category 6 - full invalidity. Illnesses were identified and automatically evaluated using the Cornell Medical Inventory standardized according to Czechoslovak conditions.

In addition to general health condition, other systems, such as the respiratory system, digestive system, motor system, etc., were tested separately. We used multifactor analysis for statistical processing, and the correlation coefficient (r) proved to be the most reliable for relating the independent variables representing health functions of the population in each area.

A regression analysis was also carried out, but the results could not be interpreted as well as the correlation coefficients.

Table 1. Types of ecologically equivalent areas.

Characteristic ecological feature	Ecologically equivalent areas												
	1	2	3	4	5	6	7	8	9	10	11	12	13
Settlement													
Urban	✓									✓			
Rural		✓		✓	✓			✓				✓	✓
Combined			✓			✓	✓		✓		✓		
Production													
Industry	✓						✓						
Agriculture		✓				✓						✓	✓
Combined			✓	✓	✓			✓	✓	✓	✓		
Scenery													
Low country	✓				✓	✓	✓		✓	✓			✓
Under mountain		✓						✓			✓		
Mountain			✓	✓								✓	

RESULTS

One of the most interesting results is that the health index is distinctly related to socioeconomic characteristics. For example, Figure 1 shows that a high health-index (in our case a rather bad health state) occurs in areas producing coal and steel (about 4.0). The absence of urban settlement is also a factor in deterioration of the health state. When these two factors work together, the health state was shown to be much worse. The best health index levels (about 3.0) seem to occur in the traditional regions of well-prospering agriculture, especially where this state is being improved by urban settlement, but a rapid deterioration of health state becomes evident in areas characterized by an extensive mountain agriculture. The health of this population is improved by the possibility of being employed in light industry. Also significant is the fact that areas with a health index of about 3.5 have a mixed settlement, e.g., practically rural settlements, but with some urban characteristics and the possibility of employment in intensive agriculture and light industry.

Some interesting correlations between factors are presented in Table 2. This table also shows the levels at which these correlations are significant. The relations can be simply interpreted. For example, the better is the health care service, the better the standard of distribution networks ( $r = +0.644$ ); the worse the supply of drinking water, the higher the proportion of population working in agriculture, which indicates the problems in supplying drinking water to the rural population. Some relations cannot be interpreted reasonably, e.g., the better the

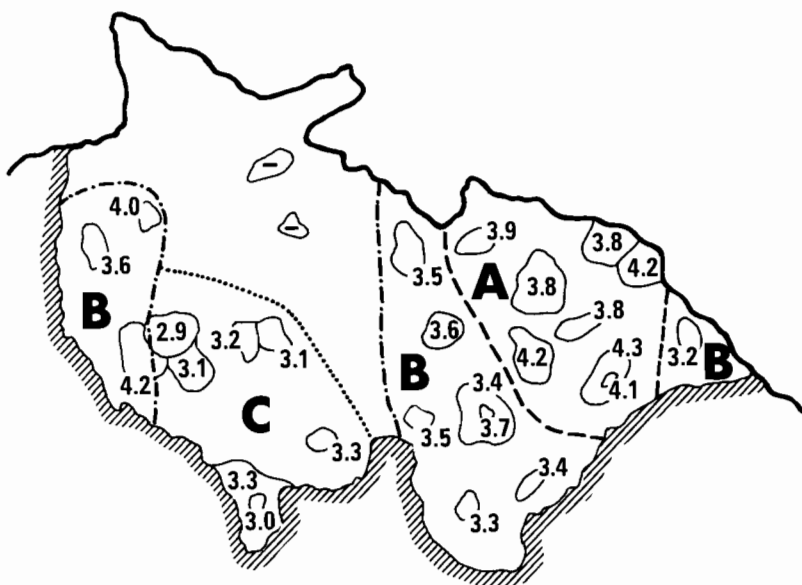

Figure 1. Socioeconomic agglomerations defined by means of the health state, Northern Moravia, Czechoslovakia.

supply of drinking water, the more adverse the climate. However, the climate presents problems when interpreting results and this factor will be mentioned in the discussion.

The relations of individual factors to health are not as clear for the 22-year-old age group as for the 52-year-old age group. In the 22-year-old age group, the correlation between the respiratory symptoms and the character of working places ( $r = 0.356$ ) is significant at the .5 percent level. This suggests that people who suffer from respiratory tract infections prefer better working conditions. The correlation of circulatory system deficiencies with high percentages of agricultural workers ( $r = 0.541$ ), can be interpreted as follows. Persons suffering from circulatory system deficiencies find a job in agriculture more easily because of fewer workers in this field and less stringent health requirements.

In the 52-year-old age group, there is a conspicuously impaired health index in all areas. However, of the environmental factors, the factor of the proportion of forested area appears to be most significant explanatory variable. As for one other example, the more adverse is the health index of the respiratory system, the smaller the forested area. It is apparent that this relationship also includes some other ones that are not directly

Table 2. Relationships among some environmental factors.

Correlated factors in the whole population of all ecological units		r
Drinking water supply	Housing quality	0.453
"	Climate	- 0.386
"	Percentage of employees in agriculture	0.547
Quality of health care	Shopping centers and service quality	0.644
Quality of waste water removal	Traffic quality	0.550
"	Percentage of employees in agriculture	0.383
"	Population density	- 0.409
Shopping centers and service quality	Afforestation	- 0.420
Traffic quality	Percentage of employees in agriculture	0.420
"	Population density	- 0.407
Air quality	Afforestation	0.418
Housing quality	Percentage of employees in agriculture	0.484
"	Population density	- 0.452
Test criterion	5% significance level	0.375
	1% "	0.482



causal but that are probably the results of other causes and relations associated with extensively or scarcely forested areas. Examples are quality of housing, density of population, quality of services, etc.

#### DISCUSSION

As already mentioned, we encountered problems in interpreting correlations between the health index and the climate. There are indications, for example, that a rough mountain climate, which should unfavorably affect the health index of the respiratory system, does not correlate satisfactorily. These difficulties of explanation and also other reasons suggest a revision of the scale for appraising climate in an ecologic unit. Such a revision could possibly lead to an improved correlation between the calculated and observed health index in individual areas. Also necessary is the continued investigation of other age groups. This work should be particularly directed to provide sufficient data for age groups between 22 and 52 years and beyond, at least at 10-year intervals.

When interpreting results, it should be borne in mind that not the entire population has been investigated. One question is whether this investigation should not cover the whole population. Another question is whether further investigation or eventually a broader listing of ecologic equivalent or characteristic features should be carried out. We hope that the theory of the basic model of human environment we have developed, which is derived from measuring population health state, is valid. We hope also that further results will follow further development.

#### REFERENCE

- [1] Miksl, R., et al., A Basic Model for the Human Environment, in D.D. Venedictov, ed., *Health System Modeling and the Information System for the Coordination of Research in Oncology*, CP-77-4, International Institute for Applied Systems Analysis, Laxenburg, Austria, 1975.

## AMBULATORY CARE IN BAVARIA

W. van Eimeren and W. Koepcke

### INTRODUCTION

This paper reports on an ongoing analysis of ambulatory care in Bavaria, which was commissioned by the Bavarian Association of Panel Doctors (an organization of almost all independent physicians formed to settle accounts and negotiate with the health insurance funds, in particular under public law--the RVO\*).

In this project, scientists from different disciplines and research institutions are focusing on the economy of ambulatory care at various levels: the individual practice; the individual types of practices such as the general practitioner, the internist, the radiologist, etc.; and the entire field of ambulatory care within the framework of the health system. In particular, it is addressing the question of which form of review could best guarantee economy.

Project coordination is the responsibility of the Central Institute (ZI) for Panel Care in the Federal Republic of Germany, located in Cologne. This presentation only serves to draw attention to the project. Initial comprehensive information is now available in an interim report which is being published by the Central Institute.

We will first explain the structure and data basis of the study and then report on the partial results obtained thus far.

### ANALYSIS SEGMENTS AND THEIR RELATIONSHIP: PROJECT CONCEPT

Figure 1 presents a broad view of the most important modules of the analysis and their relationships. The social structure of ambulatory care is illustrated against a background of demographic factors.

The concerned, active persons in this field are referred to as "agents" in the following discussion. The structure of the

---

\*RVO is the law under which panel doctor associations and non-private insurance companies work. Sections 29 and 30 refer within this frame to hospital doctors, who are allowed to practice ambulatory care.

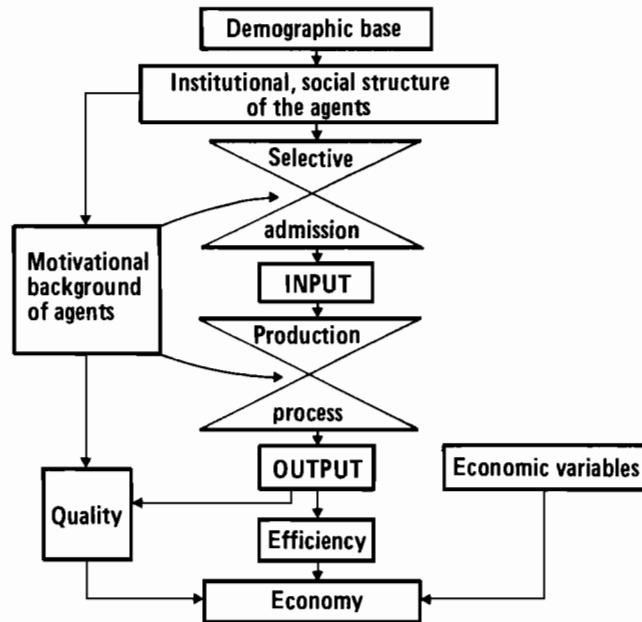

Figure 1. A synopsis of the procedure used to analyze economy of the Bavarian ambulatory care system.

process by which agents obtain access to one another and the input which is introduced into the production process from various sides, both play an analytical role in defining the production process. The different motivations and social perceptions of the agents are mutually dependent and of explanatory importance. The results of the production process can be transformed internally into efficiency criteria and externally into quality criteria by taking into account the value of the achieved effects for the various agents.

Finally, the efficiency and quality criteria serve as an input for the desired assessment of economy by taking the relevant economic data into consideration.

#### SINGLE ASPECTS OF OUR ANALYSIS

Figure 2 shows our analytical procedure in somewhat more detail. The demographic structure and the agent structure form the background of the economy analysis. Data used for the former include, for example, the age/sex, the population settlement, and the income and employment structures of the supply areas concerned. The different agents are encompassed within these larger structures,

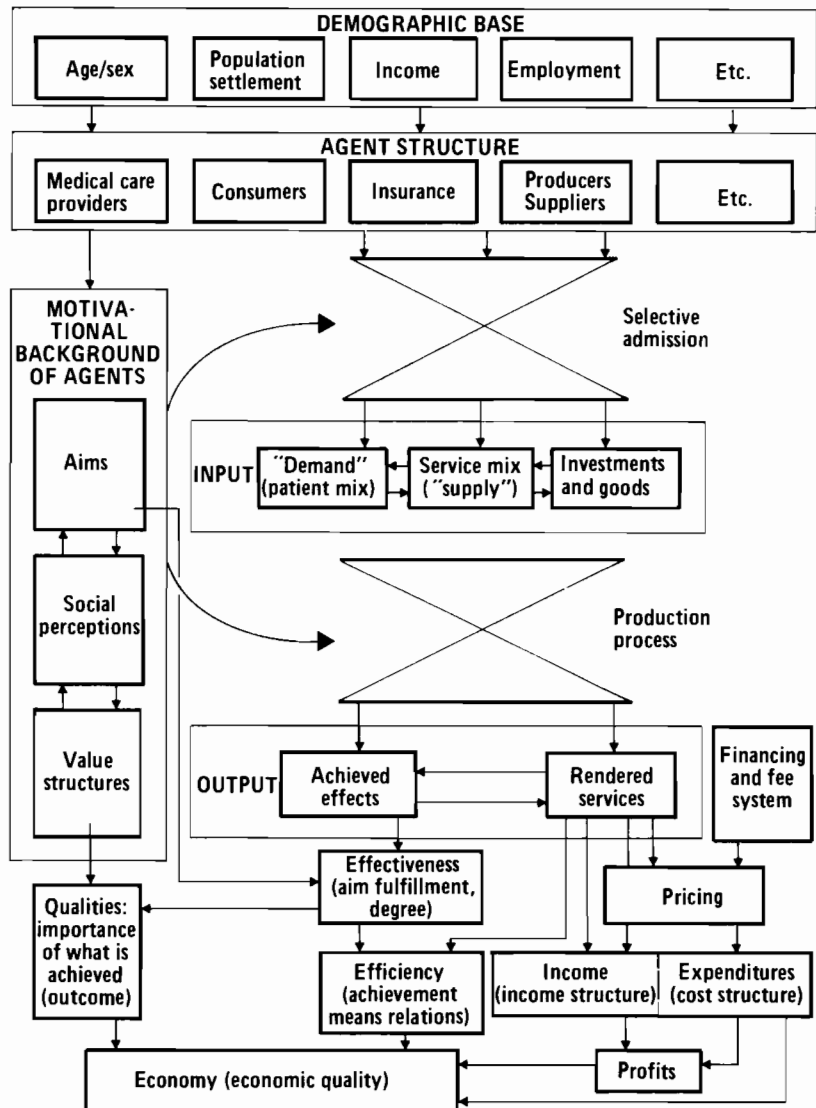

Figure 2. Detailed analysis scheme.

for example, the consumers (patients) who actually use ambulatory care and the medical and paramedical care institutions, including the persons and professions therein. The various financial institutions (e.g., the health insurance funds) are other important agents just as the producers and their distribution system (e.g., the pharmaceutical industry and pharmacists).

It also is necessary to know something about the motivations of the various agents in order to understand and evaluate the processes that operate among them. Specifically, Figure 2 differentiates between the aims of the agents, their perception of themselves and others, and the expectations and evaluations attached to the processes and especially to their results. All these factors influence the manner and extent to which the agents approach one another, and they influence the way in which access to them is impeded or denied.

Before the production process--within a practice, for example--can be either described or classified, the following inputs must be determined: (1) the demand mix (problems mix or patient mix), (2) the supply mix (supply capacity), and (3) the investment and consumption goods.

Important to analysis of the output is a differentiation between performance and results. This distinction is needed for an adequate description of the following subjects of analysis. It prevents, for example, an inadequate, and perhaps even misleading, consideration of performance types and quantities in the evaluation. Effectiveness and quality thus can solely describe the degree to which aims are accomplished and the importance of this for the various agents. Differentiation between performance and results also permits efficiency criteria to be extracted when comparing the two. This can perhaps be regarded as quality in the more restricted sense of operations research.

Consideration of financing and physician's fee systems must be introduced at this level or earlier. Compulsory fee systems (e.g., the "Schedule of Fees for Physicians) based on predetermined performance classifications (items in the schedule of fees) are found in the ambulatory field in the Federal Republic of Germany. Exact compensation within the legally predetermined framework is being negotiated by the health insurance funds and the Association of Panel Doctors.

Since, unlike in the hospital sector, income exceeding these predetermined levels does not exist for most practices, incomes can be derived directly from these data. This also constitutes the share of the health insurance funds relevant to this analysis. This monetary information, combined with the profit structure and efficiency and quality criteria, form the basis of an evaluation of the economy of the ambulatory care system--economy at the different levels according to the standpoint of the various agents; this is, if you wish, the actual desired economic quality of the system.

THE PRINCIPAL QUESTION

As we have mentioned, the principal question is what is a more suitable instrument for reviewing practice economy. In this, one must think along pragmatic lines. The instrument must be capable of being handled routinely and the data of being gathered easily and reliably. This demonstrates an important secondary goal of the project: the information imparted by existing routine data should be clarified before other data surveys are requested. There is routine accessibility, for example, to (1) the basic information concerning the types of practices, (2) the services rendered there in compliance with the "Schedule of Fees for Physicians" (GOÄ), and (3) characteristics of the affected patients including the diagnoses made.

The principal question in this study can also be formulated as: To what extent could differences between performance pattern within similar (homogeneous) types of practices based on similar cases (homogeneous groups of patients) be taken into account as an approximation (proxy measure) of economy and thus be used for the review process? Figure 3 shows some of the influences bearing on this question.

It is not possible here to go into all research aspects that would reveal the analytical quality of this operationalization of economy. But two important aspects are:

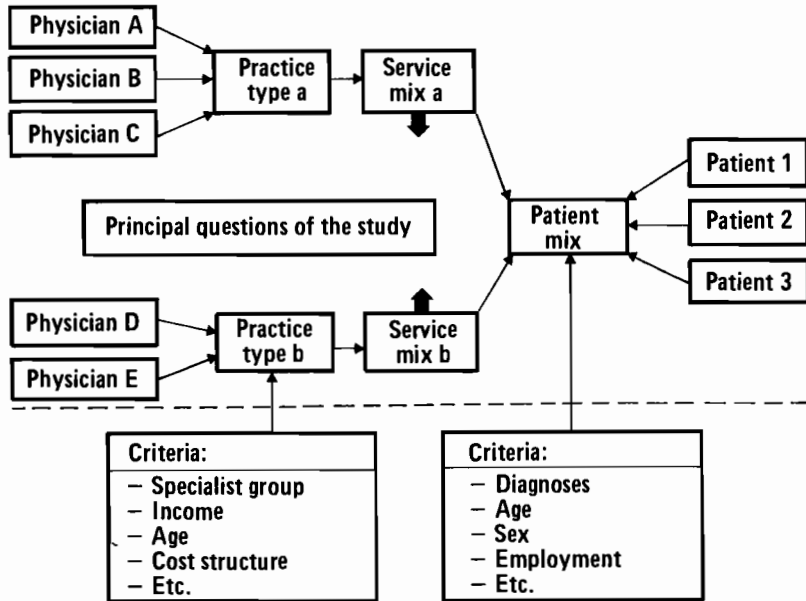

Figure 3. Influences bearing on the principal question.

1. Diagnoses are frequently made at the conclusion of treatment. Where and to what extent do they explain the originally perceived problems (as indicated by the patient mix) and thus "justify" the resulting service mix? Where and to what extent are diagnoses determined by the service potential, i.e., are "explained" by the type of practice and thus belong with the associated criteria?
2. This formalization implies moving away from measuring outcome criteria such as health indices to measuring more simply, the descriptions of effects. Is this an acceptable and objectively proxy measure of quality?

#### THE AVAILABLE DATA

Figure 4 gives an impression of the data available for analysis by the various project components. An initial differentiation can be made between: (1) data available for the entire state of Bavaria that are already stored and are computer-compatible; (2) data on forms that have been processed for machine-oriented documentation by the project itself (this could only be done for selected regions of Bavaria); and (3) data that were collected in practice observations by project members and that refer only to a small sample of practices in two regions.

Within the first data form, three different data files exist. The first file contains the information about a certain physician, patient, and performances as they occurred during the course of treatment and were registered by the physician during a quarter of the year in order to settle the account. The individual data set is therefore the information on a single document for settling the account. Annually, about 40 million of these account forms are collected in Bavaria (population: 10 million). Of course, only random samples from this enormous volume of data can be used for purposes of evaluation.

A second data file is based on individual physician practices and thus contains approximately 10,000 records corresponding to the number of freely practicing physicians in Bavaria. This includes information from the 40 million forms and information about the physician and his practice (e.g., specialty, duration of study, etc.) as far as it is in the files of the Association of Panel Doctors.

The third data file at this level contains information about the demographic structure and other aspects of the health system, such as location of hospitals, number of beds, duration of hospitalization, etc., insofar as it is available to the Bavarian Office of Statistics and appears to be of importance for the project.

The data files at the next level (regional selection) are characterized by additional information such as the age of the

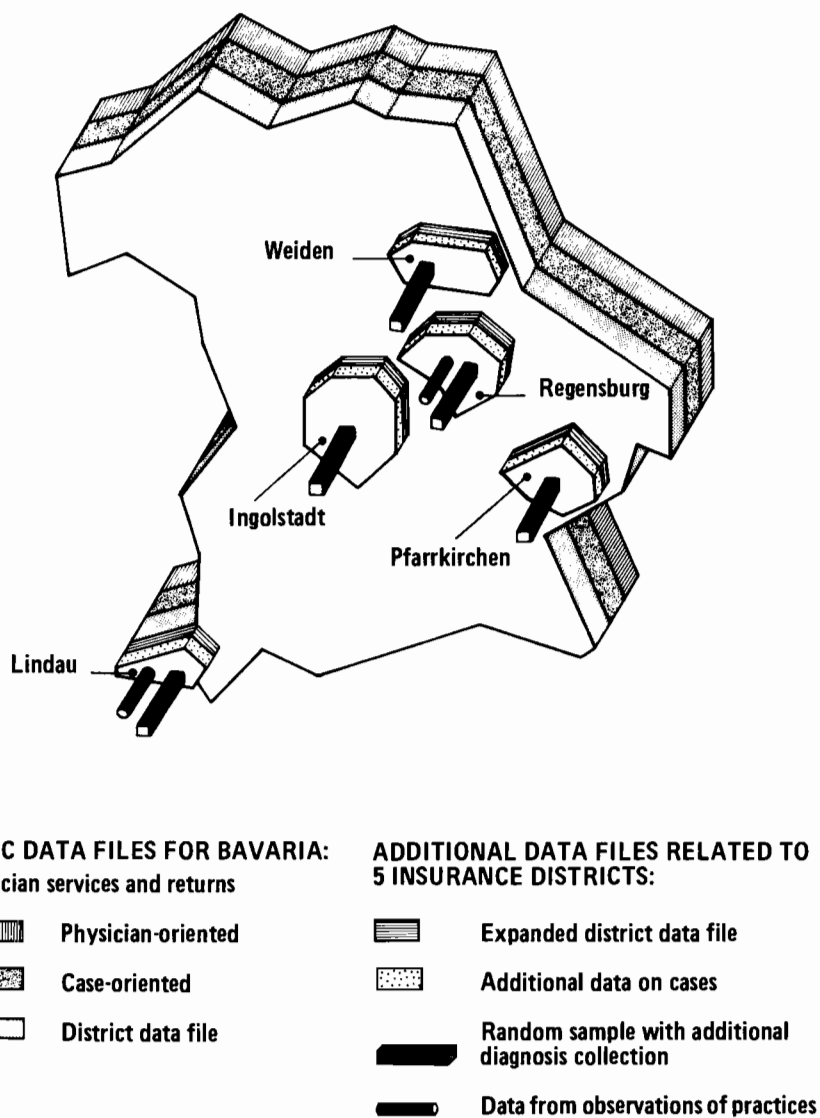

Figure 4. Geographical presentation of the different data bases.



patient, the date on which the service was rendered, as well as diagnoses. The expenditure that resulted from the detailed and qualified coding of the diagnoses makes the expediency of the routine use of this information rather questionable.

#### THE MOST SERIOUS LIMITATIONS OF THE DATA

Figure 5 illustrates that the data have considerable limitations in spite of the enormous volume. It is emphasized in this context that direct information to the "process blocks" of our analysis plan hardly exists. With respect to the second block, the "performance process", the only data that exist are based on pilot studies of individual practices. The latter raises the question of, among other things, the extent to which the performance classification of the GOA represents the process circle consisting of anamnesis, diagnosis, and therapy in an approximately realistic manner. As far as the first block is concerned, only a small portion can be observed since, of the many different feasible sections of the system in which the patient can be located and can move, only data concerning the ambulatory area are accessible to the project. This is by virtue of the transfer forms that move from practice to practice.

Finally, it must also be mentioned that an essential part of therapy, i.e., the prescribed medicines, are not contained in the aforementioned data either.

Figure 6 shows that region of the analysis scheme which has until now been taken into account adequately by the project. It will be the focus of the future endeavors of the project.

#### THE RESULTS--AN EXAMPLE

The following illustrates the type of results contained in the interim report. Figure 7 shows roughly the position of the five most important project sections in the analysis scheme which have now been largely completed.

In the project section identified as E in the Figure, the question arises as to what extent can turnovers in practices be explained by knowledge of the demographic structure, agent structure, and the fee system.

The turnover structure of a practice (or type of practice) can be described as a function of the number of cases in differentiated case classes, the number of performances administered to these cases in differentiated performance classes, and the physician's fee associated therewith. As one of its first steps, this project section posed the task of estimating the numbers of cases from the information on practice characteristics. Various approaches were employed, but the approach presented here is the result of a canonic correlation analysis.

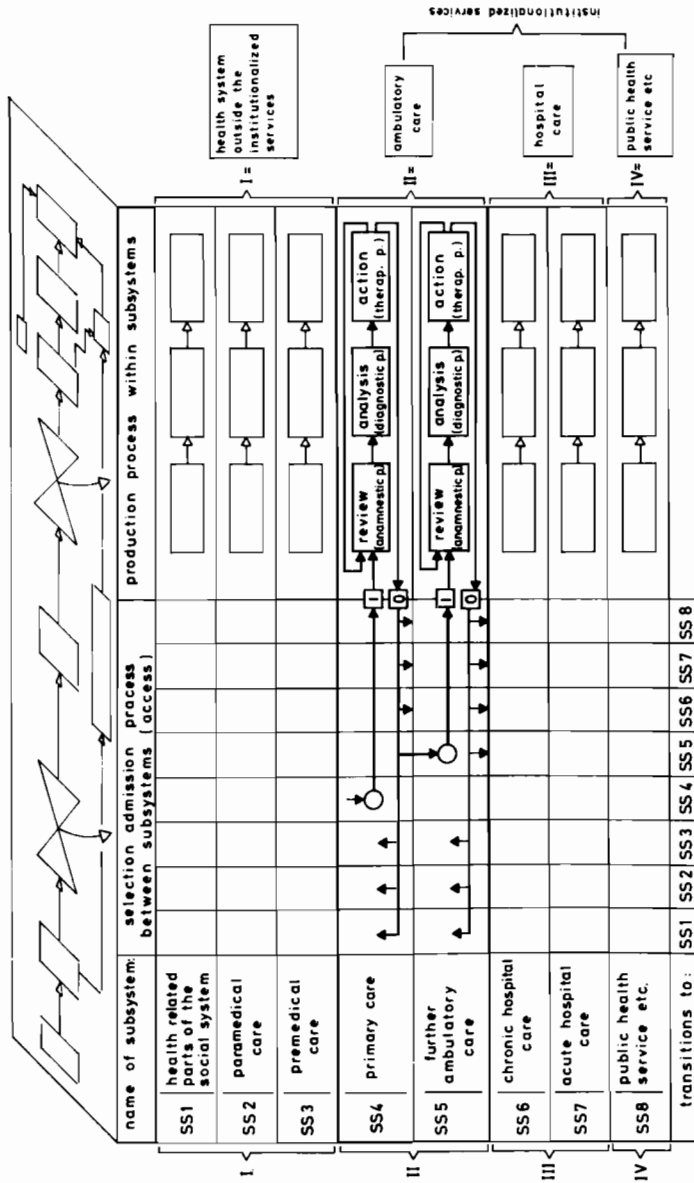

Figure 5. Ambulatory care process in the context of other subsystems.

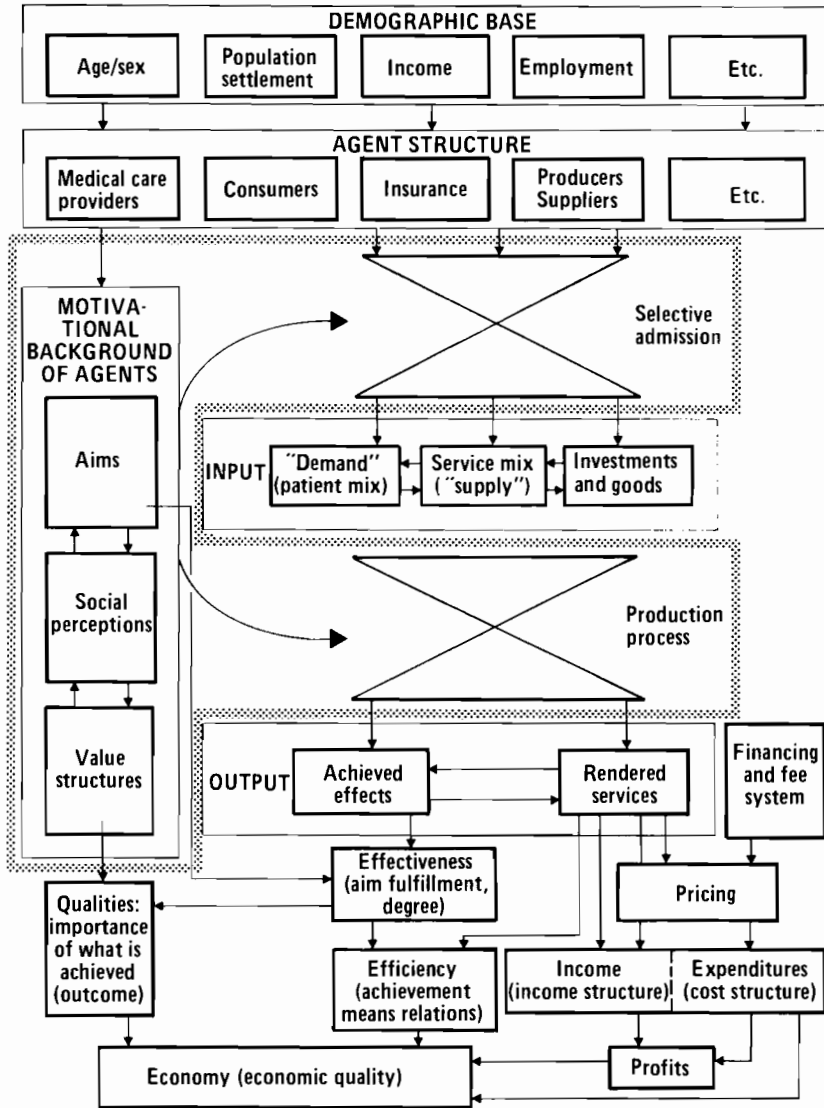

Figure 6. Up to now insufficiently analyzed research-regions.

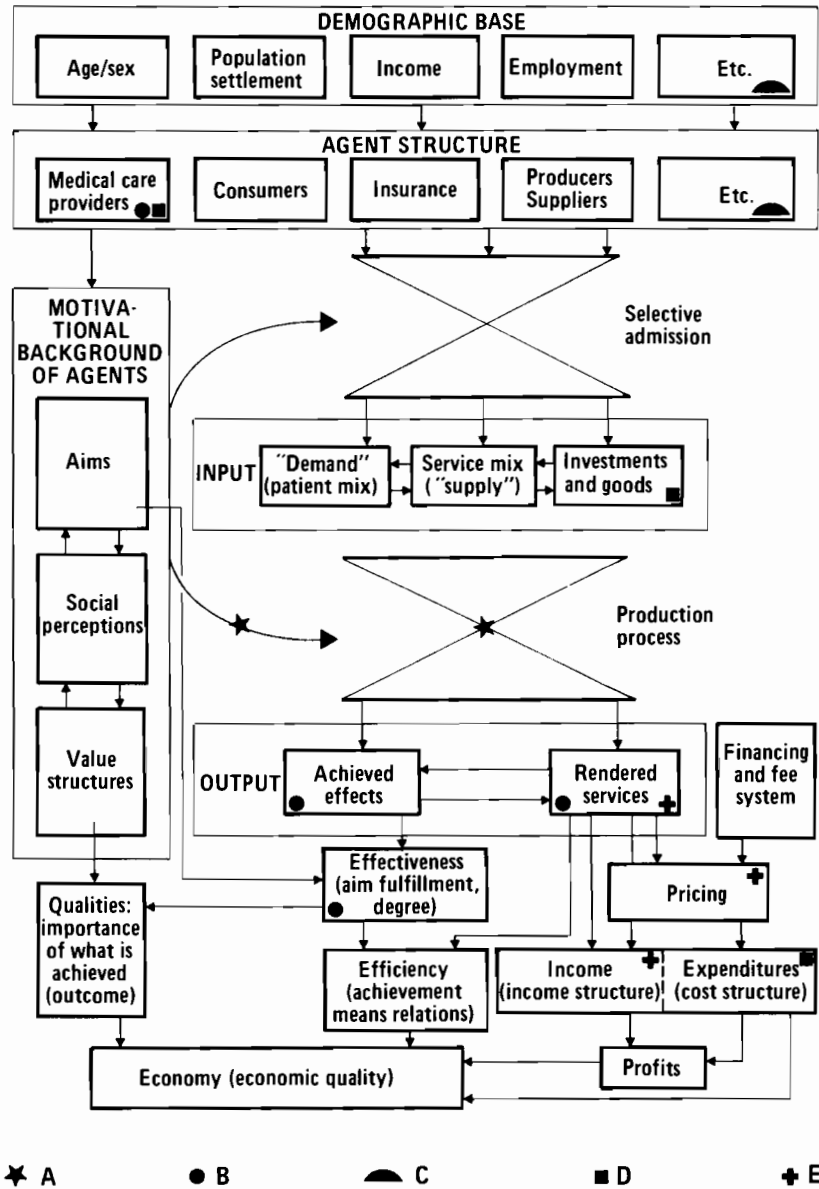

Figure 7. Main data bases for different project components (A-E) (interim report).

Ten independent variables were used:

1. Age of the physician.
2. Year in which the physician received his license.
3. Time interval between receiving the license and establishing a practice.
4. Sex.
5. Joint practice.
6. Admission according to Section 29.
7. Admission according to Section 30.
8. Admission only to non-RVO-health insurance funds.
9. Hospital doctor entitled to ambulatory care.
10. Practice outside of Bavaria but Bavarian patients.

The dependent variables included:

- Two types of health insurance funds: RVO funds, non-RVO-health insurance funds.
- Three types of insured policyholders: for the member, for members of the family, for pensioners.
- Eight types of health insurance forms: health insurance certificate, transfer form; locum tenens form/emergency form; case of request; maternal checkup; medical checkup for children; medical checkup for females; medical checkup for males; performance during hospitalization.

When combined completely, the result is  $2 \times 3 \times 8 = 48$  case types. A separate analysis was made for each of the 18 differentiated specialties (Table 1). Due to the extremely skewed distribution of the case frequency variables, these were transformed. The most favorable general result in the sense of a nearly symmetrical distribution within the individual specialties was achieved by taking the fourth root of the values.

The results in [1] show the dispersion of estimated compared to observed case frequencies as the sum in all case classes for all physicians in Bavaria for the second quarter of 1975. The correlation coefficient of .88 suggests an extremely good estimation. It is also clearly indicated that the most important contribution is in the heterogeneity between the specialties. In fact, the correlations between the true and estimated values due to the individual canonic correlation analyses within the specialist groups amounted to an average of 0.3. Very different

Table 1. 18 differentiated specialties.

<u>Specialty</u>	<u>Case number N</u>
Anesthetist	114
Dermatologist	223
ENT specialist	304
Gynecologist	590
Internist	1201
Laboratory specialist	48
Lung specialist	87
Neurologist	192
Oral surgeon	9
Orthopedic surgeon	283
Ophthalmologist	371
Pathologist	25
Pediatrician	393
Psychotherapist	7
Radiologist	211
Surgeon	410
Urologist	136
General practitioner	4653

results were obtained depending on the specialist group, ranging from approximately 0.0 in the case of anesthetists to approximately 0.5 in the case of internists and pediatricians.

Summarizing this partial investigation, it could be said that the influence of the physician and practice variables on the case frequencies is substantially different. The findings, which have become necessarily complex, cannot be included in this presentation.

As the caricature below shows, we hope that this project will make a contribution to improving the quality of ambulatory care. Otherwise, this study would go down in history solely under the heading of expenditures.

#### REFERENCE

- [1] Boese, J., W. van Eimeren, A. Schuller, and D. Schwefel, *Contributions to an Analysis of the Economy of Ambulatory Medical Care. Problem, Approach, and Initial Results*, ZI-Schriftenreihe, Band 13, Cologne, 1978.

Health services research:  
 helpful or just  
 additional expenses?

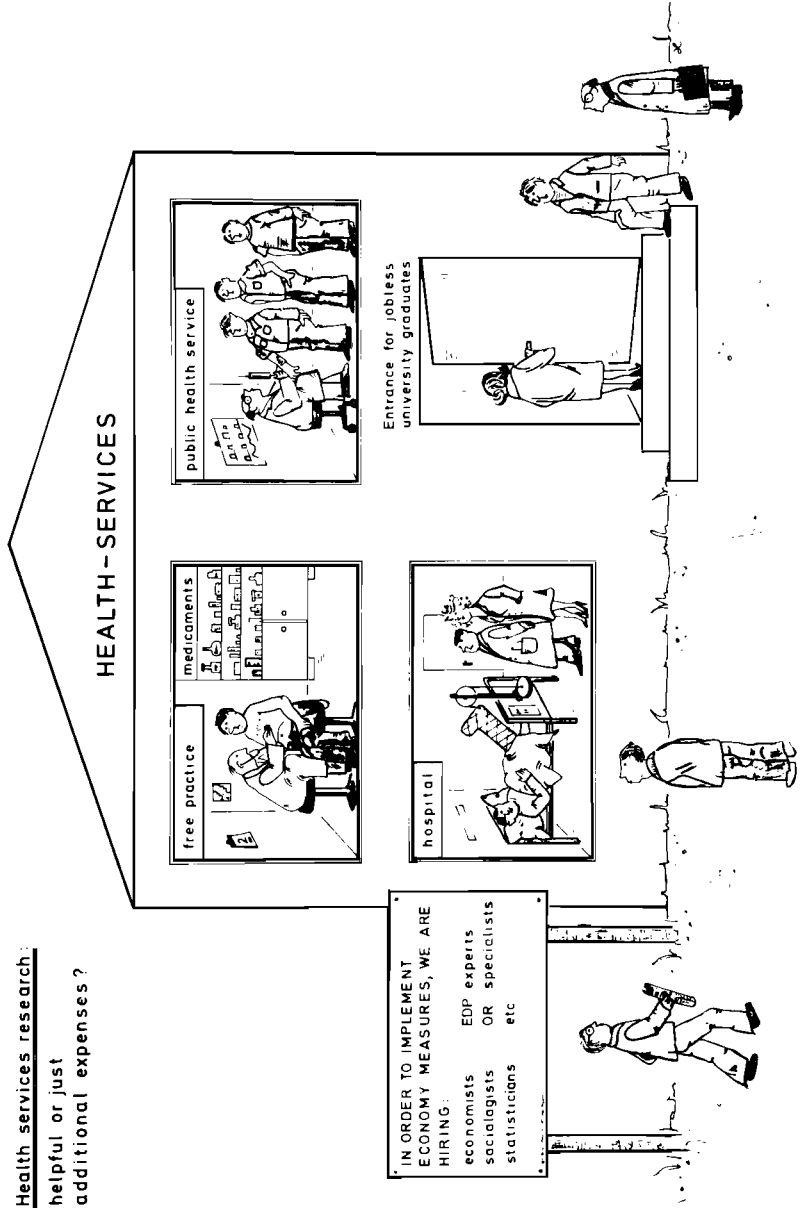

## POLITICAL MODEL IN THE HEALTH CARE SECTOR

C. Dietrich

### STATEMENT OF THE PROBLEM

In the Federal Republic of Germany, political parties, associations, organizations, and institutions directly influence the existing health system. Among these groups, some parties and unions express their ideas in the form of political guidelines and programs, which together outline possible short-term or long-term changes in the health sector.

A scientific evaluation of the past and present political health programs of parties and associations at the national (and international) level can provide information about:

- emphasis and shifts in programs over time;
- agreements and contrasts among different programs;
- influence of programs on one another over time;
- dynamics of individual political problems in the health sector (e.g., how long a certain topic remains of political interest).

Over the last few years, several countries have attempted to present the behavior of their health systems in a systems dynamics model. According to Forrester [1,2], the definition of a system includes the stipulation of a closed boundary that contains everything essential for explaining the specific behavior of the system. In constructing a model, only those elements should be included that influence the behavior being analyzed. This does not, however, imply that the system remains unaffected by external influences (e.g., the political activities of parties and associations).

It would be quite interesting then to relate systems dynamics models of health systems to models designed to forecast political behavior in the area of health. Political forecasting models in the health care area select the most probable political decisions from the many that are possible. If these decisions, taken from the political model, are included as input for the systems dynamics model, it should be possible to recognize in advance the consequences of these decisions.

From the previous comments, it is possible to formulate the task at hand as follows: development of a political model of the



health sector which, together with existing systems dynamics models, aids in understanding the effects of expected political decisions on the health system of the FRG. It is intended that this model would be applied to health systems in other countries.

### THE ANALYSIS

This model would be developed in the following seven steps (see Figure 1):

- Step 1. Development of the goal systems of the parties and associations for the last four legislature periods in comparable form.
- Step 2. Development of corresponding measures of the same parties and organizations for the relevant time periods.
- Step 3. Investigation of the duration and recurrence cycles of political discussion concerning a certain goal and certain measure.

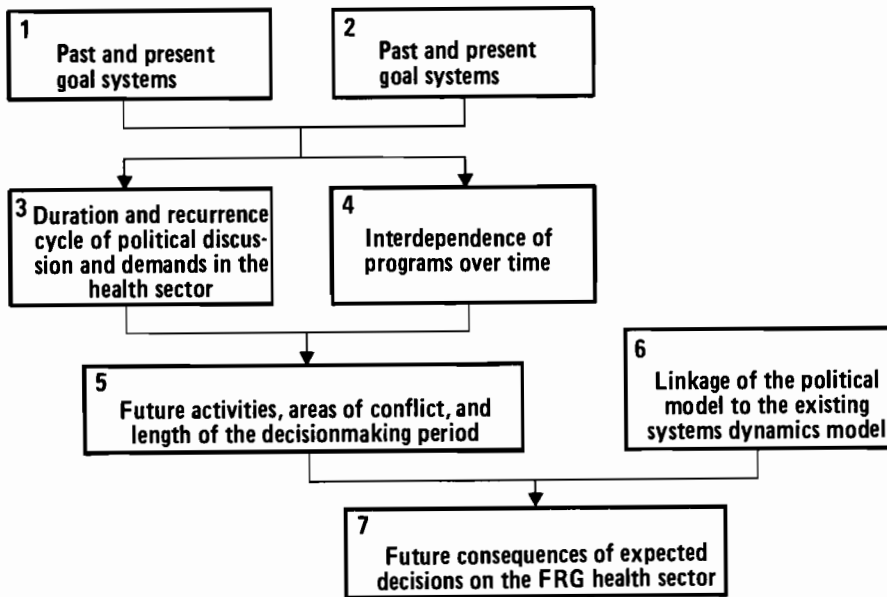

Figure 1. Flow diagram of the development of a political model.

- Step 4. Investigation of the mutual influence of political health programs on one another over time.
- Step 5. Investigation of the dependence between the government coalition in power, the length of time spent on decisionmaking, and the expected outcome of the decisionmaking process.
- Step 6. Discussion of the inclusion of measures in existing systems dynamics models.
- Step 7. Investigation of the effect of expected activities on: administrative centralization, terms of reference between doctor and patient, public vs. private financing, public vs. private health affairs, curative vs. preventive doctrines, and method of payment for physicians' services.

#### PREPARATORY WORK TO DATE

In carrying out this study, two previous investigations by the Industrieanlagen-Betriebsgesellschaft (IABG) can be consulted. In the first investigation, a formal method of goal definition (MS-Methods) was developed, which enables each separate goal to be grouped uniquely into a hierarchical goal system. Use of F. Zwicky's morphological method can guarantee the completeness of the goal system. This method allows each goal system to be newly ordered according to any perspectives. This, in turn, means that different goal systems concerned with the same area of analysis can be made comparable to each other (or convected into each other).

Because so much time is required for managing goal systems, a package program (MORVOS) was developed which, within a very short time, enables the construction, utilization, presentation, and interplay of goal systems on a monitor screen [3].

In a second investigation [4], the programs of political parties and associations in the health care area for 1974-1977 were formally analyzed. In this analysis--leaving out any interpretations of the contents--a comparison was made of the types and numbers of health policy statements of various parties and organizations. Some results of this formalized analysis are shown in the next three figures.

Figure 2 shows in histogram form, the frequency of statements made on four topics: principles, objectives, strategies, and tactics. These statements were collected from programs available in the spring of 1977. Along the right hand side of the figure are listed the absolute values of all the statements.

It will never be possible to break down neatly each measure into "strategy" and "tactic". The overlapping gray zone between

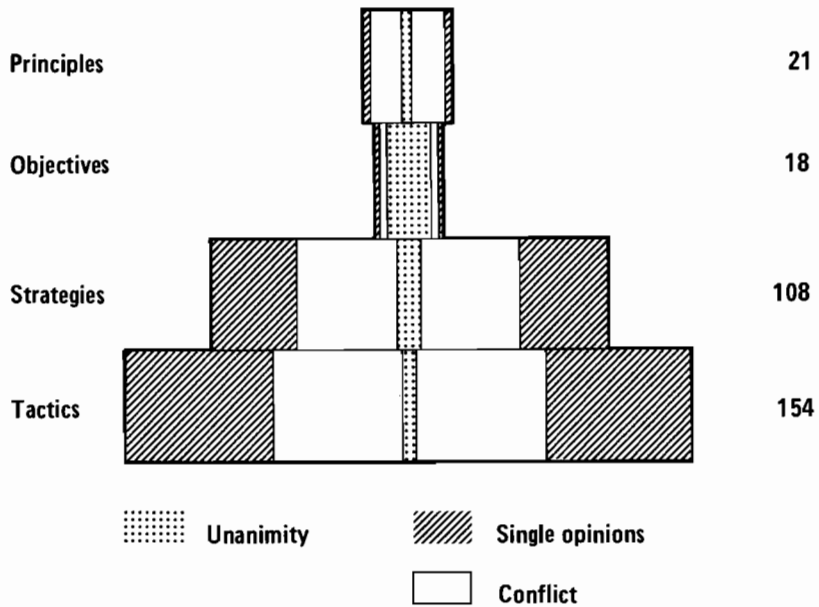

Figure 2. Histogram of health policy statements, 1977.

the strategy and tactic levels could possibly lead to a slight relative shift of the lengths of the fingers of the histogram. Most of the comments, however, remain uninfluenced by this fact.

Figure 2 is divided into three zones at each level, namely:

- The core (dotted area) in which all groups made the same statements (area of highest unanimity).
- The shaded border (edge) zone in which only one group made a certain statement (lowest unanimity).
- The free intermediate area in which each statement is made by only part of all the groups (but at least from two groups). This can be termed the conflict area.

As far as objectives are concerned, an almost unanimity of opinion dominates, although we are usually used to dealing with conflicts of goals and the necessary compromises. On the other hand, as we get closer to everyday problems and recommendations for their solutions, this unanimity almost completely vanishes. The great consensus among the various parties on the level of objectives justifies taking the list of objectives as reference for further diagrams.

Figure 3 shows the frequency of tactics associated with each of the list of 18 objectives. The solid line shows how many tactical statements are made by all parties and organizations. The lower dotted line shows how many different tactics have been suggested. From this diagram, we can easily see which topics are in the foreground of discussion.

Of course, each political party and organization has its own special issues at the strategic and tactical levels. Figure 4 shows the frequencies of common strategies between pairs of parties and organizations. The profiles look quite different from one another. However, none indicates sufficient common interest to enable an unbiased viewer to recognize or recommend any unambiguous coalition possibilities. It is only possible to say quite clearly that a government made up of all parties is not likely to force itself regarding health policy.

From the few figures shown here it can be seen that an extensive evaluation of goals and measures (measure stands here for strategy or tactic) of parties and organizations over several legislature periods can furnish us with many interesting details, e.g., about interrelations and mutual influence of programs, dynamics of individual programs, or probability of future political decisions.

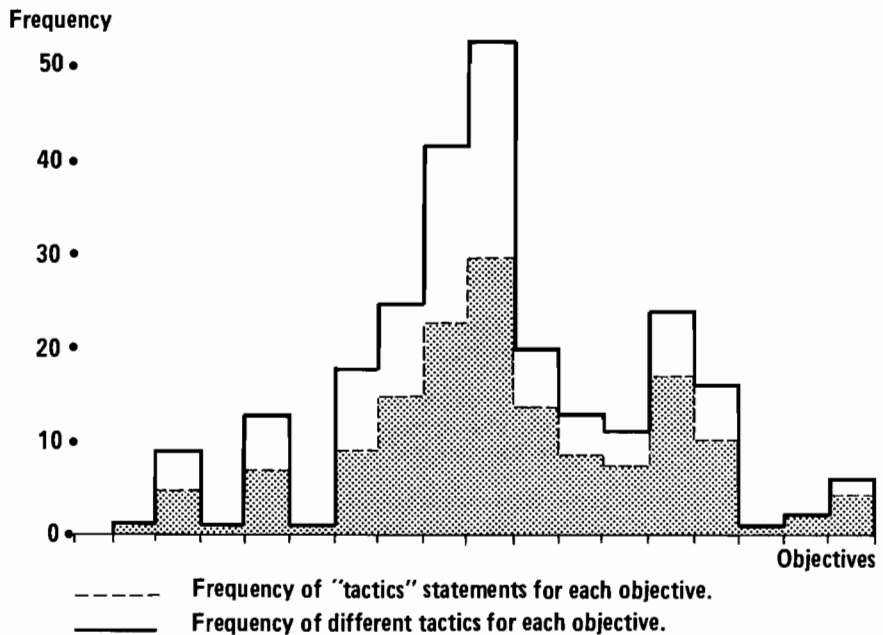

Figure 3. Distribution of tactics among objectives.

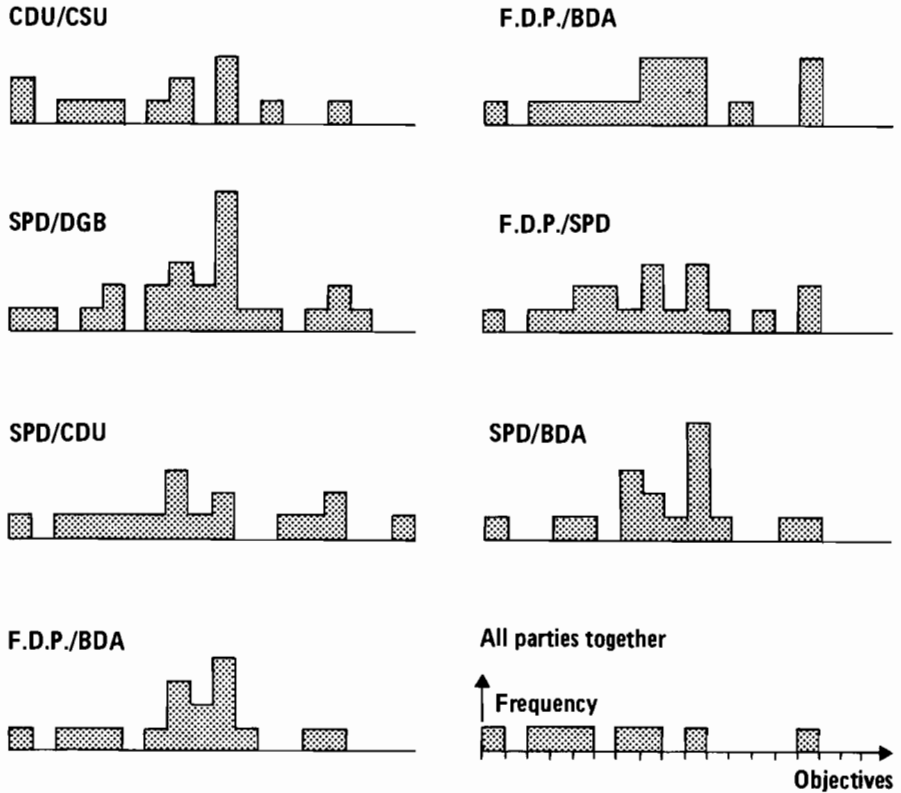

Figure 4. Distribution of strategies suggested by different parties or organizations for the same objectives.

#### REFERENCES

- [1] Forrester, I.W., *Industrial Dynamics - After the First Decade*, *Management Science*, 14, 7 (1968), 406.
- [2] Forrester, I.W., *Grundsätze einer Systemtheorie*, Wiesbaden, FRG, 1972.
- [3] Kallweit, E., *Weiterentwicklung eines Verfahrens zur Zielplanung*, IABG paper B - SZ 1091/01, Ottobrunn, West Germany, 1976.
- [4] Dietrich, C., and D. König, *Formale Analyse gesundheitspolitischer Programme von Parteien und Verbänden*, IABG Paper B - SZ 1131/02, Ottobrunn, West Germany, 1977.

## INVESTIGATION OF A HEALTH CARE MODEL AT THE TOWN LEVEL

Yu.M. Komarov

The necessity for investigating and elaborating models to improve the planning and control of health care services has been confirmed at many national conferences and meetings. Such models would permit health criteria to determine the principles and methods for constructing optimal life securing systems. Analytical modeling is also needed because of the new role and place of the health care system in a modern community. The modern health care system is penetrating ever wider into other social subsystems and is posing corresponding hygiene requirements on their functioning. Thus, besides its traditional functions (treatment, preventive control, science), the health care system has acquired a new social function based on the conduct of social hygiene investigations.

In order to better understand the tasks a community faces in maintaining and strengthening the health of its population, we have delineated a list of health demands (a tree of objectives) and built a tree of investigations intended to realize these objectives.

It is noteworthy that for all the different levels of health (communal health, health of separate groups of population, individual health) a unified approach has been accepted for a further disaggregation of objectives down to nine levels. This approach comprises three blocks: creation of conditions facilitating maintenance and development of physical and mental health; warning of the harmful effect of certain factors on physical and mental health; eliminating the harmful effects of certain factors on physical and mental health. At the present time, the emphasis in distribution of communal resources is being shifted toward the first two blocks.

Modern medicine is leaning increasingly toward preventive and social functions rather than the treatment function. It has now been established that more than 90 percent of all diseases are related directly or indirectly to environment. Having outlined this effect, we can carry out so-called primary prevention, which is massive and effective in character and reflects an offensive health care policy. For instance, constructing clarifying facilities and changing the technological procedure of a plant polluting the atmosphere would lead to a considerable reduction in lung and cardiovascular diseases and cancer.

Secondary prevention is more complicated, since it is performed on an individual basis and requires testing each and every patient using various techniques, screening included. If the primary and secondary prevention of diseases is not performed on a proper level, it leads to outbreaks of disease, including chronic with all the consequences entailed. At this point, medical treatment comes to the foreground, representing the defensive policy of medicine and health care. This process is depicted in Figure 1.

The application of modeling to health care is needed:

- to forecast a health level for establishing the optimal need in a life securing cycle;
- to evaluate the consequences of decisions made under conditions of uncertainty;

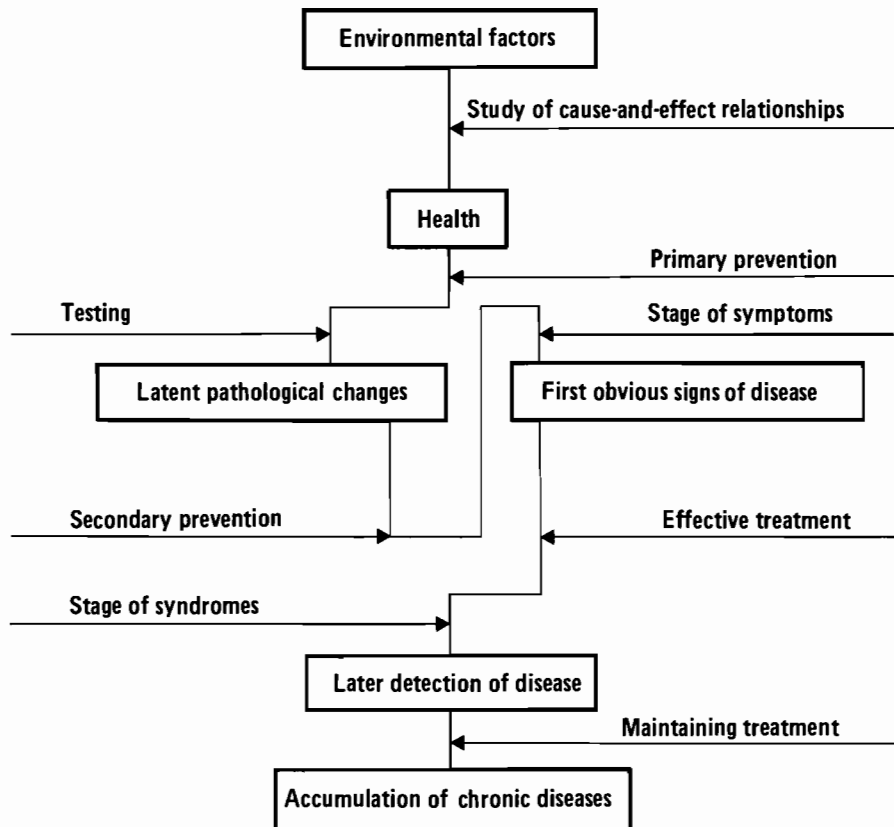

Figure 1. Stages of disease prevention and treatment.

- to contribute to medium- and long-term planning of health development under conditions of restricted resources and according to the community's goals;
- by elimination of natural experiments on a "live" system;
- to lend a scientific foundation to the priority development of various services and parts of a system;
- to optimally utilize resources allotted for the needs of the system as the whole and at its different levels;
- to plan a revision of normatives, a main impetus of the management;
- to optimize the functions of the separate parts and services of a system;
- to optimally select alternative decisions.

#### TOWN HEALTH CARE MODEL

Models are also designed for conducting business games. Considering the above, a health care model of a large industrial center has been worked out by V.V. Bessonenko, G.I. Chechenin, and Ye.N. Granica and has been in operation since 1973 in the town of Novokuznetsk, situated in southwestern Siberia (Figure 2). The principal difference in this model is the systems methodology used for its construction which is based on the conceptual national health care model worked out under the guidance of D.D. Venedictov [1].

The model is aimed at achieving three objectives:

- improvement of pollution control;
- increasing the level of utilization of resources allotted for health care needs (manpower, material, and technical resources);
- increasing the efficiency of preventive control.

Delineation of these objectives, which in their turn are sub-objectives of the health problem, has established the primary tasks to be solved by the town health care model.

#### Submodels for Pollution Control

Two submodels have been introduced for pollution control: monitoring the epidemiologic situation and monitoring atmospheric conditions. The former is based on information about each incidence of an infectious disease, which at the same time is considered



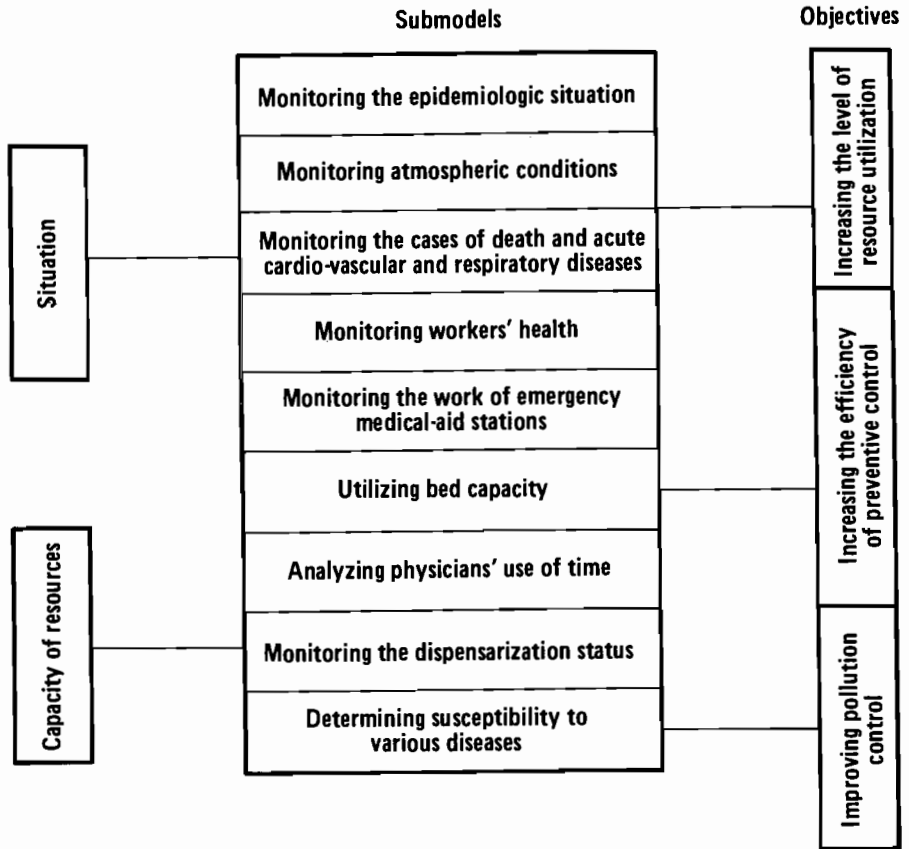

Figure 2. Town health care model.

in light of a variety of factors (place of work, water supply system, nutrition, residential quarter of the town, etc.). Being of the territorial type, this model gives information on different levels of health care control on an individual and cumulative basis (daily, weekly, monthly, annually), which allows drastic measures to be taken to prevent disease outbreaks), as well as an ongoing retrospective analysis and a determination of the correctness of decisions.

The submodel for monitoring atmospheric conditions is based on a daily comparison of data on the actual pollution of the atmosphere by 16 pollutants (dust, soot, fluor, phenol, sulfuric gas, carbon monoxide, hydrogen sulfide, nitrogen dioxide, and others) with the normatives (critically acceptable concentrations). It is also intended to detect critical situations and deliver signal information to the sanitary inspection services and industrial enterprises that have contributed to the situation.

Considering the regularities of the air mass movement introduced into the submodel, information is given about air pollution over vast areas.

The model also receives, on a daily basis, information about serious and lethal cases of cardiovascular and respiratory ailments. In its output, based on established relationships, the submodel gives forecast data about this pathology, depending on the condition of the air, which contributes to the most expedient use of health care resources. Because infant health appears to be an essential indicator of air pollution, it too has been considered in the submodel.

Worker health conditions are estimated by means of other submodels which monitor temporary disability. These measures have resulted in a substantial reduction in the disability rate.

#### Submodels for Better Utilization of Health Care Resources

To increase the utilization level of health care resources, three submodels have been built for evaluating the efficiency of and planning for emergency medical service, hospital beds, and staff, and different facilities. For the first submodel, information is given for various management levels on a daily, weekly, monthly, and annual basis. Thus, not only the amount and quality of work are estimated (e.g., that of an emergency first-aid team and each physician in it), but the emergency sick rate and reasons for calls are also analyzed.

The submodel on planning bed occupancy and hospital physicians' work uses data on bed utilization in each department and hospital and data on physician work load. Based on this, a factor is obtained on bed capacity and physicians' work time utilization.

The submodel on planning physician work load at out-patient facilities receives detailed information on visits and hours worked. The output, however, gives differentiated data for each level.

#### Submodels for Disease Prevention Control

Disease prevention control is performed using two submodels. The first submodel deals with monitoring, efficacy, evaluation, and planning of dynamic systems that observe the health status of various population groups.

The second submodel gives information on the selection of the risk groups. This submodel also uses heuristic methods of image recognition to determine the susceptibility of every person to this or that disease, and, based on that, carries out a differentiation of examination and prevention programs. Such

an approach essentially increases the medical and economic efficiency of mass medical examination systems (screenings) which are no longer being used in some countries.

It is expected that this model will be introduced into a general model of a town, region, etc., which is being elaborated in Siberia under the guidance of Academician A.G. Aganbegyan. This model has been computerized and is presently being improved from the viewpoint of information base and mathematical descriptive languages. It is also being unified and introduced in other towns, both in the USSR and abroad.

#### REFERENCE

- [1] Venedictov, D.D., et al., Health Care: A Systems Approach, in D.D. Venedictov, ed., *Health System Modeling and the Information System for the Coordination of Research on Oncology*, CP-77-4, International Institute for Applied Systems Analysis, Laxenburg, Austria, 1977.

THE SYSTEMS APPROACH TO STRATEGIC PLANNING ASPECTS  
IN THE PREVENTION OF ALCOHOL-RELATED PROBLEMS

L. Wasserman

INTRODUCTION

Although many people consume alcohol, the primary and secondary problems related to drinking behavior have only recently been linked to death and illness and their destructive socioeconomic consequences [1]. The abuse of alcohol has become a worldwide health problem requiring innovative approaches.

The extent of worldwide problems associated with alcoholic beverage purchases are documented in World Health Organization (WHO) health statistics and in recent studies calling attention to destructive consequences related to its misuse [2]. For example, mortality data on cirrhosis of the liver have been shown to be a result of alcohol misuse. Other direct and indirect medical and social conditions associated with alcohol use are only now being documented, i.e., accidents, women and child abuse, crime.

As a world problem, alcohol misuse impinges upon every nation's health care system, the productivity of its workers, and the well-being or quality of life of its citizens [3]. Thus the international health community needs to focus upon preventive strategies and health promotion, and to consider, demonstrate, test, evaluate, and implement those strategy programs that have proved to be effective during the past 20 years.

The systems approach has become an increasingly important instrument by virtue of its process, methodology, and applications in the health field. For the complex structure of interrelationships among the individual elements of alcohol itself requires that we look at prevention strategies in a systematic manner such that the objectives of strategies are measured in terms of a set of goals: the minimization of alcohol-related problems.

Any strategic plan must focus upon a methodological approach in which prevention programs can be considered before their implementation. The development of such a strategic plan would be unique when one considers its lack of application in the area of alcohol. Establishing the foundation of a planning system to incorporate strategic formulation and design is particularly important when considering the available manpower and financial resources for alcohol programs. To these ends, the planning process provides the adaptation to environmental changes facing all health programs.

The U.S. National Institute on Alcohol Abuse and Alcoholism (NIAAA) is aware of the importance of the planning process to its program goals and objectives and is developing a National Alcoholism Plan which will address its direction and policy requirements for the next five years. This plan will concentrate on integrating federal activities in the area of alcoholism and related problems to insure that administration policies are implemented in support of our nation's goals. This plan is unique in that it includes partnership and participation from national and voluntary organizations and state and local governmental bodies involved with the product alcohol.

It has become apparent to the health research community that the systems approach provides the framework for planning at the policy, strategic, and operational levels. This paper will set out to define a systematic procedure for analyzing and evaluating problems related to alcohol misuse that would result in a set of alternative strategies directed at reducing such problems.

#### SYSTEMS VIEW OF THE PREVENTION ASPECTS OF ALCOHOL-RELATED PROBLEMS

A systematic approach toward identifying and assessing factors affecting alcohol-related problems needs to be conceived through a disciplined framework. Clearly, carrying out controlled experiments in laboratories is not applicable. Therefore, we must set up a conceptual model for making comparisons between alternative ways of approaching problems systematically in the formulation of testing strategies and research hypotheses.

The conventional view of the health care system and the preventive aspects of improving health care status are described in Figure 1. Figure 2 outlines the dynamics of prevention and how it interacts with promoting the health of target populations, thereby reducing the incidence and prevalence of alcohol misuse. This suggests areas to consider in evaluating interactions between target population and problem areas to be studied and prevention strategies to be tested.

Figure 3 shows the dimensions of alcohol problems and the interrelating components that result in a sequence of program characteristics. Research, demonstration, and evaluation are necessary before programs are introduced into varying settings.

Prevention strategies represent a delineation of the complexities involved in reducing alcohol-related problems. The identification of variables which alone or together interact between the product alcohol and the individual are outlined in Figures 4 and 5. These variables form the framework for the selection of strategies.

Figure 4 suggests the patterns of formal and informal expressions that result in actions that influence drinking behavior. Similarly, Figure 5 suggests a more comprehensive set of variables,

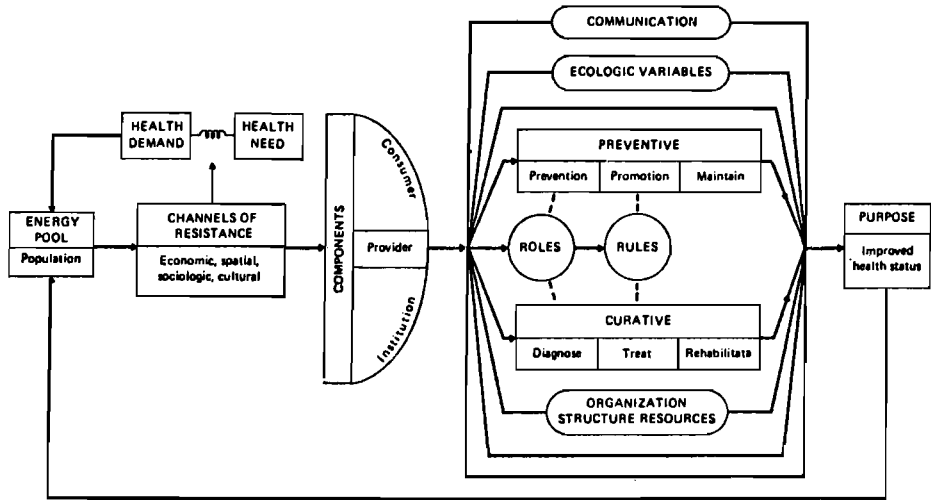

Figure 1. Conventional health care system model.

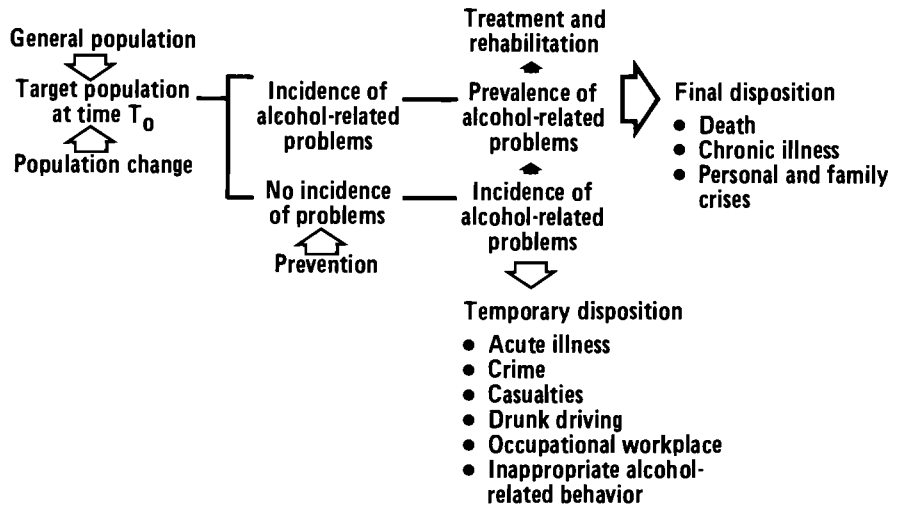

Figure 2. A systems view of alcohol-related problems.



Figure 3. Dimensions of alcohol-related problems.



Figure 4. Social policy and strategies for prevention and control of alcohol-related problems.

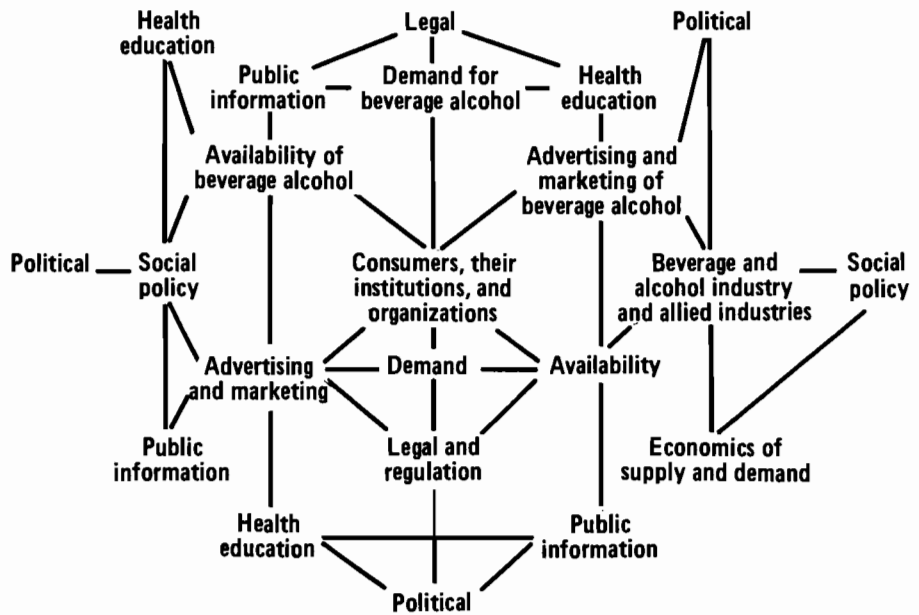

Figure 5. Strategies for prevention and control of alcohol problems.

all acting upon individual consumption of alcohol. The role of the beverage alcohol industry and the regulatory aspects of governmental bodies provide a linkage for selecting preventive strategies for alcohol problems.

Research conducted on the drinking patterns of the population indicate the complexity of the high-risk groups. Problems afflict young and old, affluent and impoverished, etc.; there is no boundary. As a result, we can identify the potential target population for which each prevention strategy may be significantly different. Population can be broken down into: race--caucasian, black, other minorities; age--children K-12, college age 16-21, adult 22-64, adult 64+; sex--male, female; status--work, nonwork, military; and community--welfare, social disruption.

The alcohol journals have begun to define the problem areas of alcohol misuse. As a result, these problems can be grouped (Table 1) along with outcomes of dysfunctional behavior and outcomes of events. These outcomes are measurable and provide a basis for evaluation, that is, cost-effectiveness, health status, etc. Along with this table, one can superimpose the target populations and prevention strategies that operate upon each combination of problems.



Table 1. Alcohol-related problems.

Category	Problem areas	Outcome
Family	Child abuse Marital discord and violence Teenage drinking Spouse abuse	Accidents Crime Family disruption Life crises Disability Impairment
Accidental death and injury	Drunken driving Fire Home accidents Recreational accidents Industrial accidents Suicide	Disability Death Property damage Injuries
Chronic health problems	Cirrhosis of liver Brain damage Cancer Heart disease Psychological	Disease Cause of death Disability Impairment Depression
Acute health problems	Alcohol and drugs Fetal alcohol syndrome Gastrointestinal Ulcers	Short-term illness Hangover Impairment Disability
Crime-related problems	Homicide Armed robbery Assault and battery Rape Other sexual abuse	Injury Property damage Death Disability
Occupation	Unemployment Insurance Disability Absenteeism Accidents Reduced productivity	Loss of productivity Property damage Job disability Social work disruption
Inappropriate alcohol-related behavior	Illness Public drunkenness Human behavior Embarassing behavior	Social disruption Injuries

Application of the systems theory involves a wide spectrum of conceptual views of alternatives and consideration of the complexities of drinking behavior and variables to be defined in any model. Demonstrating and evaluating the impact of alternative strategies as outlined becomes enormously expensive. As a result, one can through the art of systems analysis formulate a conceptual model incorporating the variables affecting strategies, problems, and outcomes (see Figure 6).

The selection of strategies requires that goals and objectives serve as guidelines for measuring the effectiveness of programs. Goal-setting is important in that it is flexible and adjusts to the means available.

Prevention strategies as described are specific actions that can achieve goals and objectives. Table 2 represents a number of categoric strategies for prevention policies and programs. Although not stated, these approaches toward reducing alcohol problems resemble in part facets of the distribution and sociocultural models.

Each of the strategies are seen as having different effects upon target populations and alcohol-related problems. As a result, we need to define a matrix indicating these relationships between applicable strategies and problems for each high-risk group in order to measure the relative effectiveness of potential outcome.

The matrix in Table 3, which relates strategies against alcohol-related problems, provides the framework for examining what do we know, availability of data, existing research findings, program area costs to implement strategy, and an overall methodology for program evaluation. Additional dimensions such as time

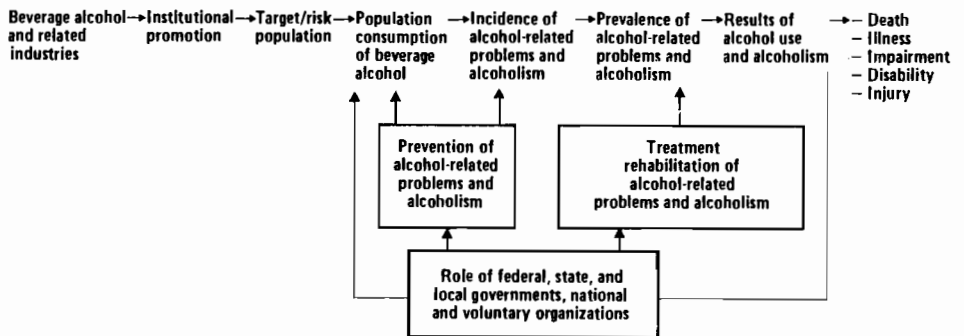

Figure 6. A systems view of beverage alcohol and related industries--relationship to the outcomes of alcohol use and alcoholism.

Table 2. Strategies for prevention.

---

Strategies	
Legal	Federal, state, and local laws Criminal law and police powers
Regulation	Setting of controls on dispensing of alcoholic beverages Advertising of alcoholic beverages Licensing regulations
Health education	Promotion of ways to encourage avoidance of misuse Well-being Quality of life
Social policy	Federal government and other governmental policy on alcoholism Religious community Societal norms
Economics	Taxes on beverages Surcharge on products used for alcoholic beverages Elimination of deduction for business purposes
Behavioral	Changing existing beliefs about the use of alcohol Peer group influence Knowledge of individual responsibility toward drinking behavior
Physiological	Search for the causal relationship between alcohol use and health consequences Labeling of product's ingredients Cautionary label on beverage alcohol regarding product's dangers to one's health

---

line, form of project (research, demonstration, and evaluation), as well as target risk population can be affixed along with this table.

A process for selecting strategies is a critical component in the development of a strategic planning system (Figure 7). The development of a planning format for an organization to implement an evaluation of a set of strategies (Figure 8) is necessary to ensure that its goals and objectives are met.

The implementation of strategies and goals also depends on available resources and constraints. Resources refer to the budget allocation for program funding which is critical at a time in which all health programs are vying for limited resources.

The constraints with respect to alcohol are particularly relevant, considering the emotional and political aspects of

Table 3. Strategies for prevention of alcohol problems.

Categories of alcohol-related problems	Strategies for prevention				
	Legal	Regulation	Health education	Social policy	Economic
Family					
Accidental death and injury					
Acute and chronic health problems					
Crime-related problems					
Occupational/work place					
High-risk groups					
Inappropriate alcohol-related behavior					

beverage alcohol [4,5,6]. For example, elected officials who take a position on an issue involving alcohol taxes, zoning laws and regulations, and drinking age must take the political consequences. Also, one cannot forget the economic consequences of the product that brings about income to the community in the form of taxes and to businesses dependent on its supply and distribution.

Thus, selecting strategies is complex since social and cultural customs, economic impact, regulatory and legal aspects of the problem all interact and converge upon supply, distribution, and individual drinking behavior. It is evident that the psychological, political, and social effects of implemented strategies must be considered balanced against the clear health and social dangers that consumption brings to the individual and community.

One can, however, proceed with developing a set of criteria for selecting strategies and programs themselves in terms of severity of the problem, number of people in a problem category, future trends, economic and social costs associated with alcohol misuse, and impact upon the population and resources needed to implement strategy. Each of these can be ranked according to impact and importance.

RECOMMENDATIONS

A study using the systems approach should be undertaken to examine and evaluate the impact of prevention strategies and the testing of hypotheses as they relate to alcohol problems. The

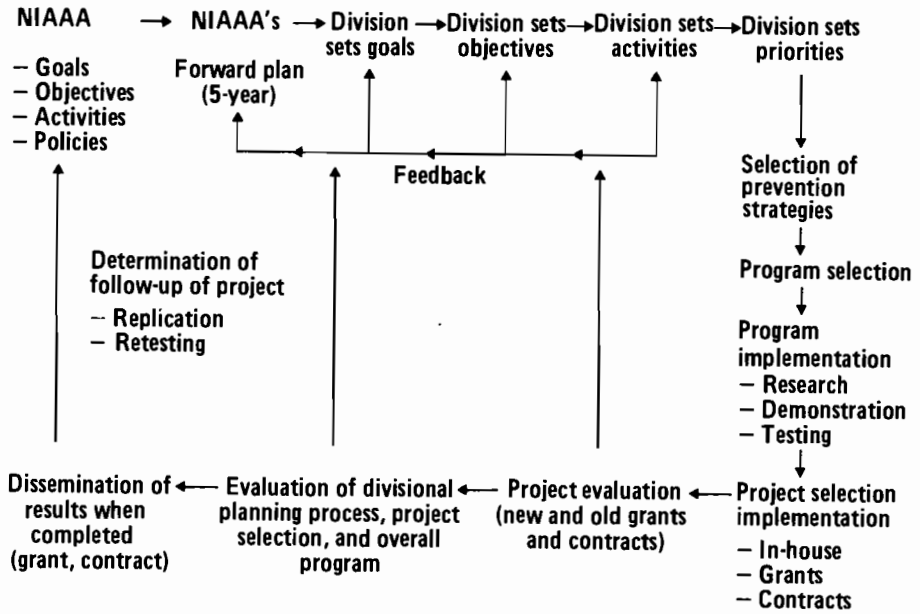

Figure 7. Planning steps of a division of prevention.

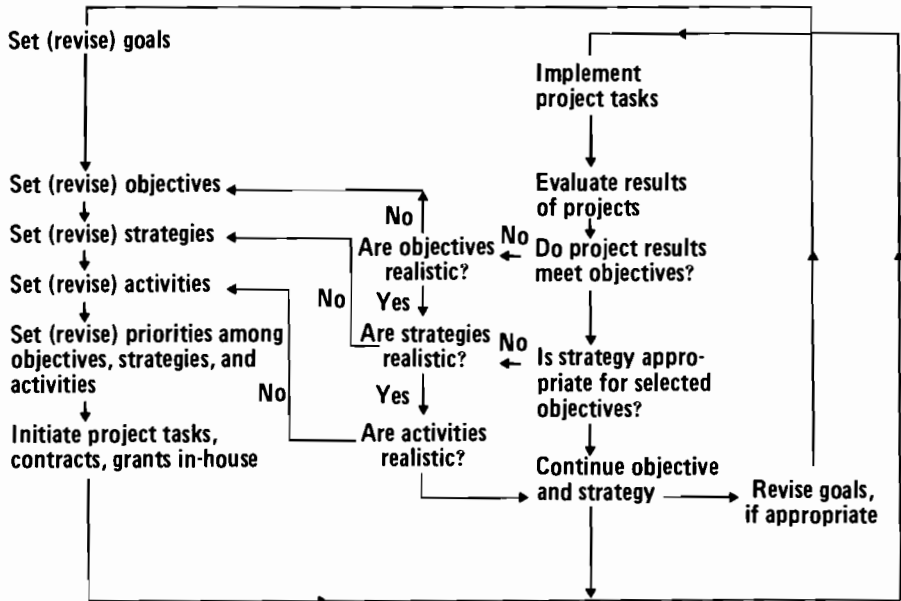

Figure 8. Logic flow of a strategy planning system.

systems dynamics as developed by Forrester seem to be an ideal choice for explicating the systems whose characteristics have been defined. To do this, national organizations through the auspices of the NIAAA and other organizations, should establish a research team to explore the requirements for such a model. Policy issues need to be examined through evaluation research techniques and countries must cooperate in the sharing of health and socioeconomic statistics. The results of this effort will provide new emphasis to an ever-increasing world alcoholism problem.

REFERENCES

- [1] Department of Health, Education and Welfare, Public Health Service, *Alcohol and Health--New Knowledge*, U.S. Government Printing Office, Washington, D.C., 1974.
- [2] Masse, L., J.M. Jullian, and A. Chisloup, *Trends in Mortality from Cirrhosis of the Liver, 1950-1971*, World Health Organization Statistics Report 29, 1976.
- [3] Moser, J., *Problems and Programmes Related to Alcohol and Drug Dependence in 33 Countries*, World Health Organization Report, 1974.
- [4] Beauchamp, D., Exploring New Ethics for Public Health: Developing a Fair Alcohol Policy, *Journal of Health Politics, Policy, and Law*, 1, 3 (1976), 338-354.
- [5] Plaut, T.F.A., *Alcohol Problems, A Report to the Nation*, Oxford University Press, New York, 1967.
- [6] Room, R., and S. Sheffield, eds., *The Prevention of Alcohol Problems: Report of a Conference*, Office of Alcoholism, Health, and Welfare Agency, State of California, 1975.

## DISCUSSION

This discussion session on the development of the national health service models was chaired by Dr. Spies.

Dr. Rousseau opened the discussion by noting that the correlation between low socioeconomic status and heart attacks, which had been described by Dr. Fleissner with reference to the Austrian data, had also been found in Montreal. Dr. Rousseau felt these findings were surprising and contrary to expectation.

Dr. Gibbs then asked whether Dr. van Eimeren's model was descriptive or built on the purpose of simulation. Dr. van Eimeren replied that this depends on the type of information one wishes to extract from the available data. If it is possible to use routine data as a proxy for physicians' economic behavior, then the model could become dynamic; however, it is questionable whether physicians' associations in West Germany would be interested in such an approach. Dr. van Eimeren explained that in West Germany a set of data is usually used for only one decision; thereafter, people whose interests were injured by the results of the analysis will raise arguments about the validity of the data, etc. A scientist can never regard his research as neutral, for people will always react emotionally to the results. Although scientists in a research institution may wish to subject a set of data to further analysis, often it is not possible to secure permission from the organizations that had originally supplied the data. Also, if the new research is not in line with the function of the donor organization, the "law of confidentiality" will be violated. Dr. van Eimeren then added that in West Germany, like the United States, there is great interest in assessing the quality of care and achieving small changes in the behavior of the actors in the health care system.

Dr. Hartgerink asked Dr. van Eimeren whether he felt that information could be gleaned from data that was collected without an explicit purpose. Dr. van Eimeren replied that much routine data, including microcensus data, is worthless. Dr. Hartgerink felt this depends on one's philosophy about information; in his opinion data can be transformed into information under certain conditions. He asked Dr. van Eimeren if he denies that a continuous flow of data can contain information. Dr. van Eimeren argued that very few data are worth gathering routinely and warned against "information pollution". As an example, he explained that data had long been collected in West Germany on the risk factors associated with women who gave birth in hospitals. Because it was necessary for a woman to pose a risk in order to secure a hospital delivery, doctors were found to be indiscriminately assigning risk factors to all their obstetric cases.

Therefore, such data proved to be useless. In Dr. van Eimeren's opinion, if a scientist undertakes a study of the health care system, it is best to collect new data aimed at answering specific questions.

Dr. Mandil noted many countries have a general rule that dictates that much information must be routinely collected. However, not all of it is useful.

Dr. Rousseau addressed the problem of response reliability, observing that if data will be used in a manner detrimental to the respondent, the respondent is greatly motivated to lie. Often it is necessary to provide a real incentive for truthful answers. One procedure used by health insurance agencies in Canada is to ask patients if they actually received the treatment for which their physicians were demanding remuneration.

Dr. van Eimeren voiced the opinion that the quantity of data collected is related to the value of the data, for reliability can only be controlled on a small scale. He suggested that research is needed to determine how much data should ideally be collected.

Dr. Spies concluded the afternoon session with some general remarks on the foregoing discussion. He noted the fact that all the analyses thus far presented were incomplete. He felt, for instance, that the analysis of economic factors associated with health status could go farther. Dr. Spies then commented on the "overexaggerated skepticism" caused by researchers' own lack of confidence about the reliability of their data. He felt, too, that it is false to try to model everything, for frontiers or limits will be reached where the interrelationships between variables are not understood. Dr. Spies concluded from the session that interesting modeling work is in progress; in his opinion, everyone can profit from the experience and methodological approaches of modeling.



PART IV

Planner's Requirements for Models



PRIORITIES FOR HEALTH AND PERSONAL SOCIAL SERVICES  
IN ENGLAND: THE CENTRAL PLANNER'S REQUIREMENT  
FOR HEALTH CARE SYSTEMS MODELING

C. Graham

INTRODUCTION

The Constitutional Framework in England

The planning, management, and delivery of health services in England depend on an agency relationship between, on the one hand, the Secretary of State for Social Services (Minister) and the Department of Health and Social Security (DHSS) operating at the national level, and, on the other hand, the National Health Service (NHS), operating subnationally through Regional Health Authorities (RHAs) and Area Health Authorities (AHAs), including Health Districts. It is the duty of the Minister to "promote the establishment...of a comprehensive health service designed to secure improvement in the physical and mental health of the people of England...and the prevention, diagnosis and treatment of illness, and for that purpose to provide or secure the effective provision of services" [1].

The Minister has wide general *powers* to provide health services and specific *duties* to provide medical, dental, nursing, and ambulance services, including hospitals and other accommodation, and facilities for the care of expectant and nursing mothers and young children, for the prevention of illness, for the diagnosis and treatment of illness, and for family planning. But the Minister's specific duties to provide services are qualified "to such extent as he considers necessary to meet all reasonable requirements".

The Minister is responsible for providing services and facilities, not for providing diagnosis and treatment, etc. The patient's doctor (or other professionals with clinical responsibility), not the Minister, decide whether and what treatment is appropriate. For services provided by general medical, dental, and ophthalmic practitioners and the pharmaceutical service, the Minister makes "arrangements" with practitioners who are responsible for providing services as independent contractors.

THE SCOPE FOR HEALTH CARE SYSTEMS (HCS) MODELING IN ENGLAND

The newly devised processes for improving the planning and resource allocation processes of the recently reorganized DHSS and NHS illustrate the scope for HCS modeling, and the extent

to which such systems have already been used for these purposes, especially at the national level with the DHSS.

Within this context, the scope for HCS modeling can be summarized in terms of the following main areas of national planning activity: planning, resource allocation, information, and monitoring.

#### Planning and Resource Allocation

The planning and resource allocation processes of the NHS and DHSS were designed to operate on the basis of the agency relationship described above, in which most of the responsibilities are delegated to health authorities but with the chain of accountability stretching back through the Minister to Parliament and the people. These processes, therefore, form a most important part of the organization of NHS and DHSS.

The planning process comprises three main features in terms of organization and management:

- An essential management feature which the Minister requires NHS to adopt is a system of control in which performance is monitored against plans and budgets.
- Planning systems are seen as a principal means of achieving a clear line of responsibility for the whole NHS from the Minister down to and within AHAs, with corresponding accountability from the AHAs back to the Ministers through the DHSS.
- The NHS planning system is set up in such a way that the Minister and health authorities exercise the main management control for functions covered by NHS legislation.

Thus the planning process provides the main means by which the requirements of the law are made explicit and can be monitored in accordance with the law.

The resource allocation process has a clear relationship to, and a very considerable influence on, the organization of the NHS and DHSS and their planning processes. In particular, the resource allocation process provides:

- a realistic framework in which planning options can be considered and a balance of priorities agreed upon;
- a need-related baseline, showing the share of the available resource that should be consumed by a given population.
- an important first stage in planning the provision of services for defined populations;
- an organizational tool for monitoring performance.

Accordingly, DHSS has been operating a comprehensive planning process, drawing since 1974 on a Balance of Care Model devised by our Operational Research Service (ORS). Since 1976, NHS has been operating a complementary planning process [2], and both NHS and DHSS introduced in 1976 an improved method of resource allocation based on the recommendations contained in the report of the Resource Allocation Working Party (RAWP) [3].

### Information Systems

The very improvement of the planning and resource allocation processes serves to illustrate for the central planner the apparent deficiencies in the existing information systems in England. For example:

- Too much information is collected and processed overall but not enough is collected on morbidity, patient flows, specialty costing, and out-patient activity.
- Information collected for central planning purposes is not clearly related to the operational needs of NHS. This leads to duplication of information, and, more importantly, it encourages local planners to ignore centrally produced information.
- Present systems are not flexible enough to accommodate the inevitable changes that can be foreseen, either in terms of fundamental changes in the balance of care in England (e.g., from care in institutions to support in the community) or in terms of international requirements, (e.g., the need to accommodate the Ninth International Classification of Diseases).
- Present systems do not provide for compatibility between the main sets of activity, finance, and manpower statistics collected centrally and locally. For example, in the Balance of Care Model, ways had to be found of relating these separate sets of sometimes conflicting statistics which, moreover, do not cover the same time period.
- The presentation of data needs to be much improved, especially if it is to be used by the nonscientific planners and policymakers. At a meeting of the Royal Statistical Society some time ago a professor at the London Business School laid the blame for this on the producers of data!

In England, therefore, we have recently begun to review existing information systems and services in the context of our improved systems for management, planning, and resource allocation. In this task, as in the earlier planning and resource allocation tasks, we will be relying heavily on our Operational Research Service and especially on their HCS modeling facility.

### Monitoring

The reorganized NHS and DHSS were designed to operate and interact with one another by means of a clearly defined monitoring relationship. We are still in the process of sorting out our ideas, but it is clear that many aspects to this relationship would benefit from the use of HCS modeling. For example:

- the planning relationship, in which DHSS attempts to monitor the overall performance of NHS against their agreed plans;
- the client group and service relationship, in which DHSS attempts to monitor NHS performance with respect to a particular health care program, e.g., services for the mentally ill [4] and mentally handicapped [5];
- the financial relationship, in which DHSS attempts to monitor NHS performance in terms of accounts, cost statements, and audit;
- the organization and management relationship, in which DHSS attempts to monitor NHS performance as a whole in terms of the original legislation;
- the health relationship, in which DHSS attempts to monitor the effects of all these measures on the levels of health observed in the community at large.

### SOME PARTICULAR APPLICATIONS IN ENGLAND

As outlined above, many recent developments in England have given rise to the need for HCS modeling. Our Operational Research Service has been heavily engaged in three applications in particular.

#### Distribution of Revenue: National Formula and Process

Ministers asked DHSS to devise a new method for the distribution of revenue in order to achieve a fairer sharing of resources across England that was responsive objectively, equitably, and efficiently to relative need. The underlying objective was defined in terms of equal opportunity of access to health care for people of equal risk. Given the absence of absolute measures of need, it was necessary to devise suitable proxy measures of relative need. These were devised separately for nonpsychiatric in-patient services, day-patient and out-patient services, community services, ambulance services, mental illness hospital in-patient services, and mentally handicapped hospital in-patient services. In each case, the approach taken was to devise a suitable weighting to be applied to the resident population of each RHA, based on which the revenue was distributed to each RHA. The main problem was finding a suitable proxy measure for morbidity.

### Morbidity

Many factors other than age and sex affect the need for hospital in-patient services--social, occupational, hereditary, environmental, etc. The difficulty is not in determining which factors are likely to be influential, but in quantifying their influence and eliminating overlap between them. We concluded therefore that the most reliable indicator for assessing regional differences in need, as independent as possible of supply, was mortality statistics. These statistics cover the whole population, are readily available, and permit compilation by place of usual residence.

The quality of the statistics, including analyses by cause of death, is high. The crude death rate shows a considerable regional variation (maximum exceeds minimum by 38 percent for both males and females). Even when allowance is made for age structure--which has a marked effect on comparative death rates--the residual variation is still as high as 28 percent for males and 21 percent for females. Figure 1 illustrates the variations.

The reasons for the pattern of differential regional mortality are not wholly understood, but it is believed that regional differences in morbidity explain the greater part of it and that statistics of relative differences in regional morbidity, if they existed, would exhibit the same pattern as those for mortality. Some support for this assumption is provided by a comparison of mortality rates, adjusted for age and sex, with such regional morbidity-related data as exist, similarly adjusted. The comparison reveals significant positive correlations.

The maps in Figure 2 show the broad similarity between regional differences in mortality and data derived from sickness benefits statistics and the General Household Survey. Mortality statistics also present an opportunity to relate differential morbidity to health care need by reference to conditions in a way that no other sources permit. It is possible to examine the variation in mortality between regions by diagnostic conditions--using the underlying, not the associated, causes of death--grouping the conditions according to the 17 chapter headings of International Classification of Diseases (ICD). The statistic used is the Standardized Mortality Ratio (SMR) which compares the number of deaths actually occurring in a region with those that would be expected if the national mortality ratios by age and sex were applicable to the population of that region. In this way, the unique pattern of mortality in each region can be established and calculated separately for each condition or group of conditions.

Many of the commonest conditions--including some that lead to death--place relatively little demand on health care services. Others require expensive care, perhaps over a long period. This relationship can be established by reference to the national figures of hospital bed utilization for each condition category

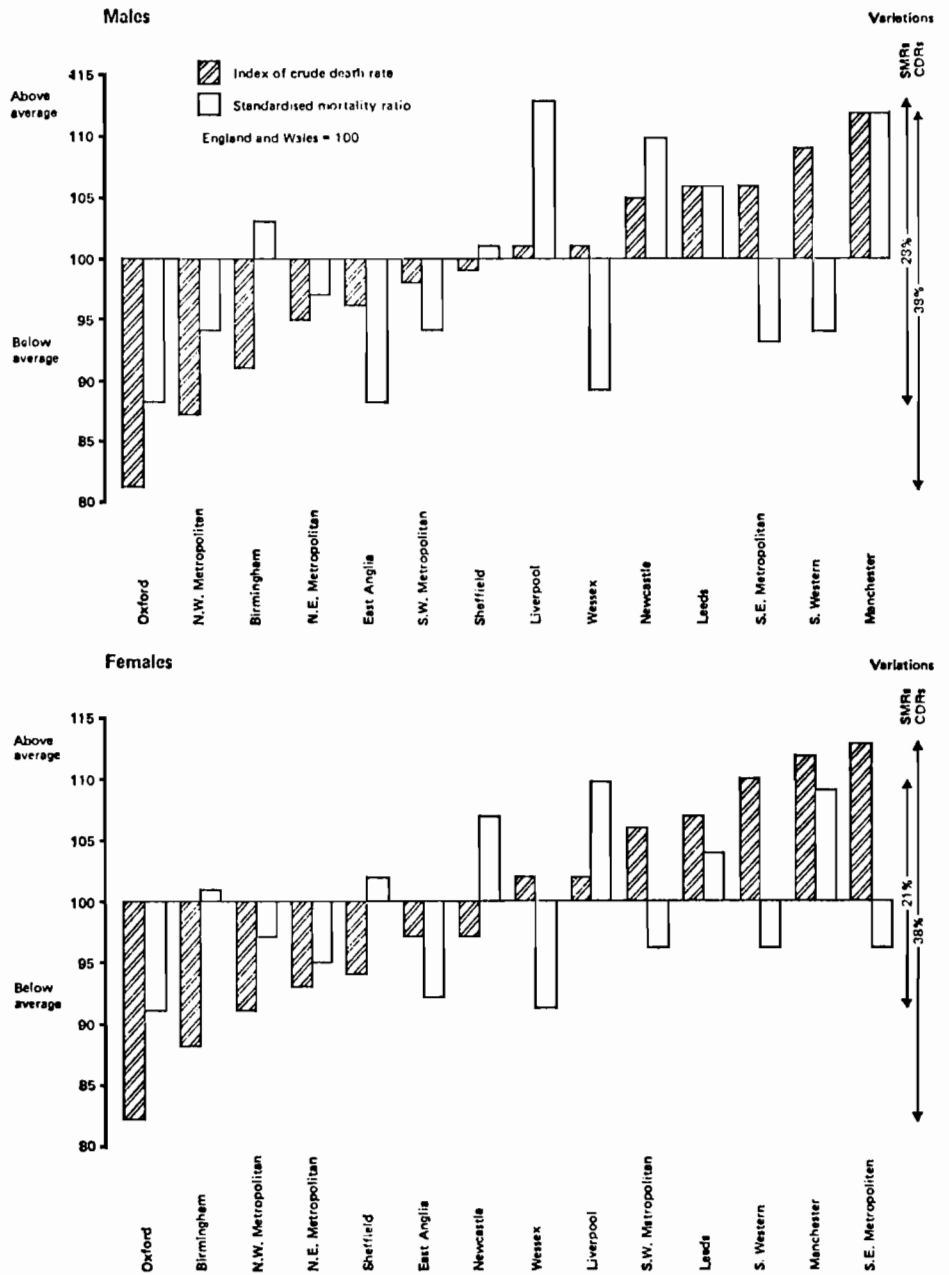

Figure 1. Effects for each Regional Health Authority of standardizing 1971 crude death rates for age, males and females.

Source: [3]



Standardised mortality ratios, 1972

Persons

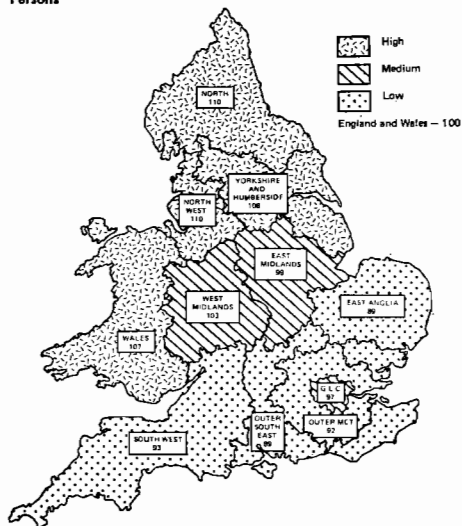

Subdivisions of England and Wales are standard statistical regions

Certified spells of incapacity standardised for age, 1972

Males\*

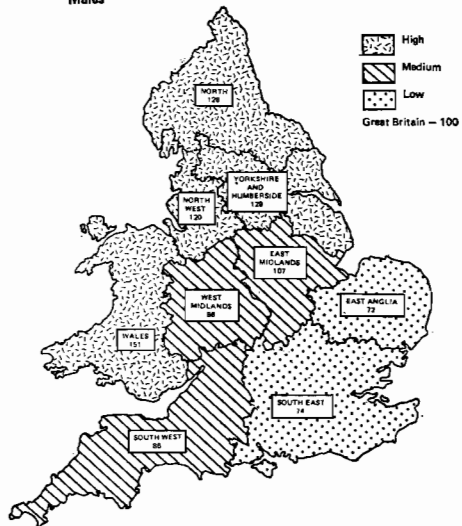

\*Females have been excluded because of the large proportion who are not insured for sickness benefit

Self reported chronic illness standardised for age and sex, GHS 1972

Persons

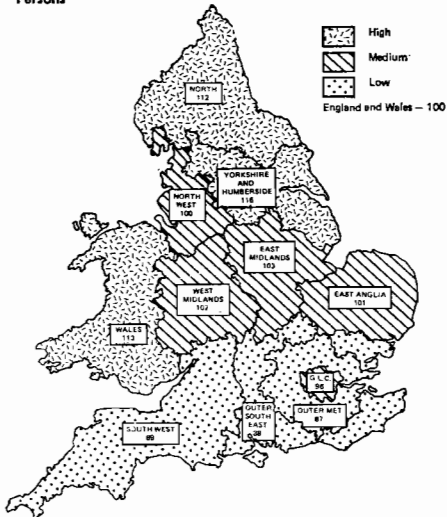

GHS data: Acute sickness is defined as restriction at any time during a two week reference period of the level of normal activity caused by illness or injury. Chronic sickness is defined as a state of long-standing illness, disability or infirmity.

Self reported acute illness standardised for age and sex, GHS 1972

Persons

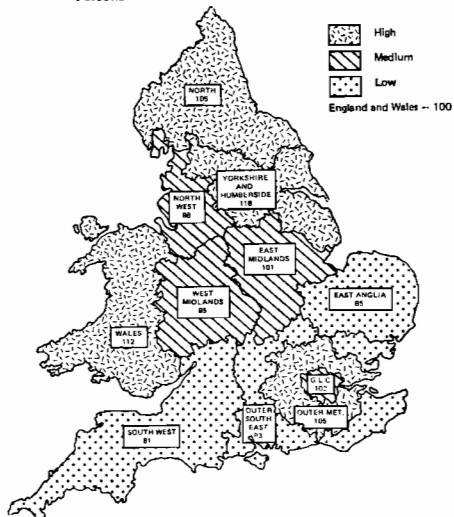

Figure 2. Regional differences in mortality, certified spells of incapacity, self-reported chronic illness, and self-reported acute illness, 1972.

Source: [3]

considered and incorporated in the calculation to provide the final link in the chain from mortality through morbidity to need for health services.

To each region's population, we applied national age/sex utilization rates for each individual group of conditions, calculated a standardized mortality ratio for each group, and combined the two weighting factors for each condition. This resulted in a set of weighting factors independent of regional differences in the supply of NHS facilities and reflecting morbidity differences between different parts of the country over and above those resulting from age and sex disparities. The method ensures that, in applying SMRs by condition, account is taken of the proportionate national bed utilization type for each condition.

Figure 3 shows how the results compare with those of a population weighting based on hospital utilization analyzed by age and sex alone. For certain conditions where mortality is very low (e.g., skin diseases and conditions of pregnancy), SMRs are unlikely to be a good guide to morbidity, and we omitted these from our calculations. Age/sex weighting alone is a good indicator of the need for maternity services but it can be further improved by modifying the age/sex weighting for ICD Condition XI (conditions of pregnancy, child birth, puerperium) to reflect fertility rates standardized for age, in the same way as other condition categories can be modified by SMRs. In short, to cover

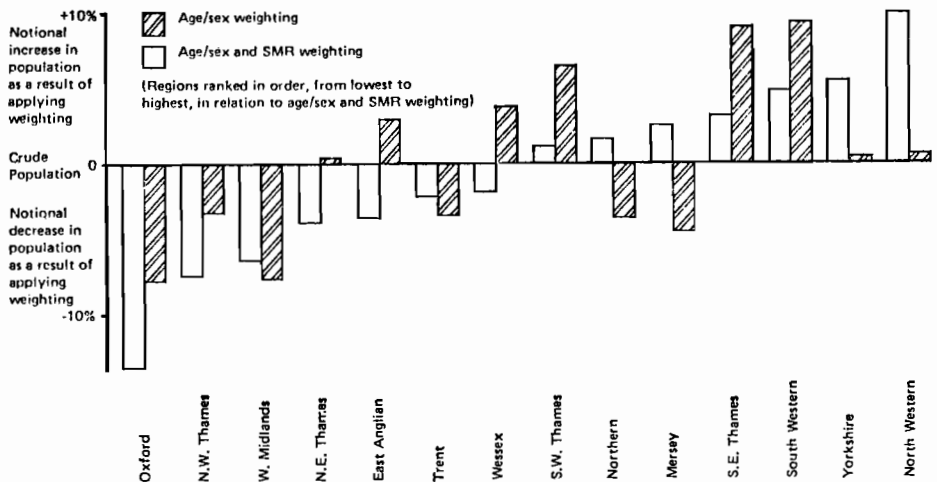

Figure 3. The effects of age/sex weighting and age/sex SMR weighting (applied to each region's crude population).

Source: [3]

morbidity with respect to acute nonpsychiatric hospital in-patient services, we weighted the population for age and sex by national bed utilization for each condition and adjusted it to take into account condition-specific SMRs for each region. SMRs for conditions unlikely to lead to death, e.g., skin diseases, were not used. For conditions of pregnancy, child birth, and puerperium, SMRs were replaced by an index of fertility rates standardized by age.

#### Establishing Revenue Target Allocations

The full process produced seven separate weighted populations for each region. These were combined into a single weighted population for each region in proportion to the most recent information available on relative expenditure nationally on the services concerned. The revenue available for services nationally was then notionally distributed in proportion to each RHA's weighted population to arrive at the revenue target allocation for each RHA (see Figure 4).

In settling the proxy measure for morbidity and deciding on the total process of revenue allocation, great use was made of models produced by our Operational Research Service.

#### Setting National Policy Objectives

The DHSS planning process has been used for two main purposes over the past three years: (1) to help the Minister and officials in determining the broad balance of national policies 10 to 15 years into the future, and (2) to evolve priorities and strategies for the implementation of policies by the NHS three years into the future. All this is designed to improve decisionmaking and management of resources. Planning has been defined as deciding how the future pattern of activities should differ from the present, identifying the changes necessary to accomplish this, and specifying how these changes should be brought about. In this process, politicians and administrators at a national level have resorted to the use of proxy measures--related to requirements of equity, relative need, fair distribution, and their own priorities for health--which are the more specific indicators needed to evaluate particular health programs or services. But it is most important that those responsible for central planning and decisionmaking be asked to state their policies and declare their priorities in the light of the resources available before any subnational planning process is put into effect. This forces the Minister and his officials to approach the task realistically; it provides clear guidelines for local planners; and it avoids the counterproductive effect of abortive local planning.

The first step in such a process is to attempt to answer the question "Where are we now?". In England, this was tackled in terms of three main elements: population structure, existing expenditure patterns, and declared policies for service development.

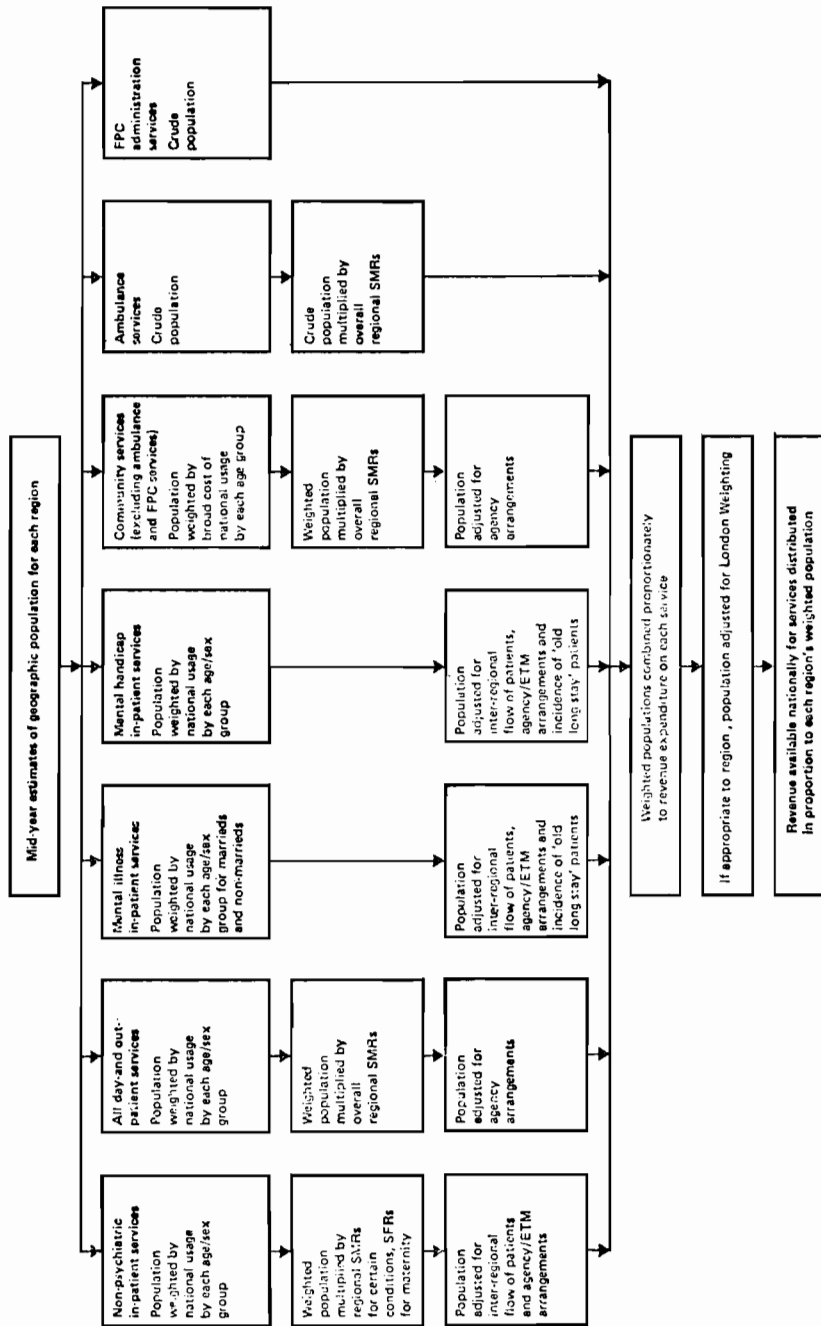

Figure 4. The build-up of a revenue target.

Source: [3]

### Population

Figure 5 illustrates the past, present, and projected future population structure in England and reveals, for example, that in the last 10 years, the number of people over 65 has increased by more than a million to more than 6.5 million--over 14 percent of the population (nearly a third of them living alone). Over the next 20 years the over-75s are expected to increase by nearly a third to just under 3 million. And by 2001, the proportion of people aged over 85 is projected to increase to about 1 in 75 of the population. It also reveals that if the downward trend of the birthrate is reversed, the number of births and of children under five is likely to reach the 1971 level by 1991 and the number of children under 16 will have dropped dramatically by 1989. The Minister must therefore take such factors into account in setting the national objectives.

### Expenditure

There is a growing realization in most developed countries that for some years at any rate public expenditure will need to be constrained, which is likely to have a serious impact on expenditures for health and personal social services. This highlights the need to examine variations in expenditure patterns within such programs and geographically. Table 1 illustrates the current expenditure per capita by program and RHA in England. It reveals, for example, that taking expenditures per population unit, weighted and adjusted in accordance with the RAWP report proposals described above, the lowest region is spending £56 per capita and the highest region £78 per capita. How much these and other variations in expenditure patterns reflect differences in relative need is not known for certain at this stage but they clearly point to some major inequities in the distribution of services that must be corrected. This calls for a more thorough examination of expenditure patterns as part of the general process of setting priorities, along the lines described below.

### Service Developments

In deciding on national objectives, the Minister has to examine the intention and effect of existing policies for service development. In some cases, long-established policies exist for certain services (e.g., for services for the mentally ill [4] and mentally handicapped [5]). In other cases, the analysis of the population structure and expenditure patterns will point to the need to develop new policies in certain key areas.

For example, such an analysis pointed to the need to examine existing policies for the acute hospital services and the maternity services. Figure 6 reveals, for instance, an increase in the cost of acute services by an average of 3 percent a year, reflecting a similar increase in staff numbers, a decrease in

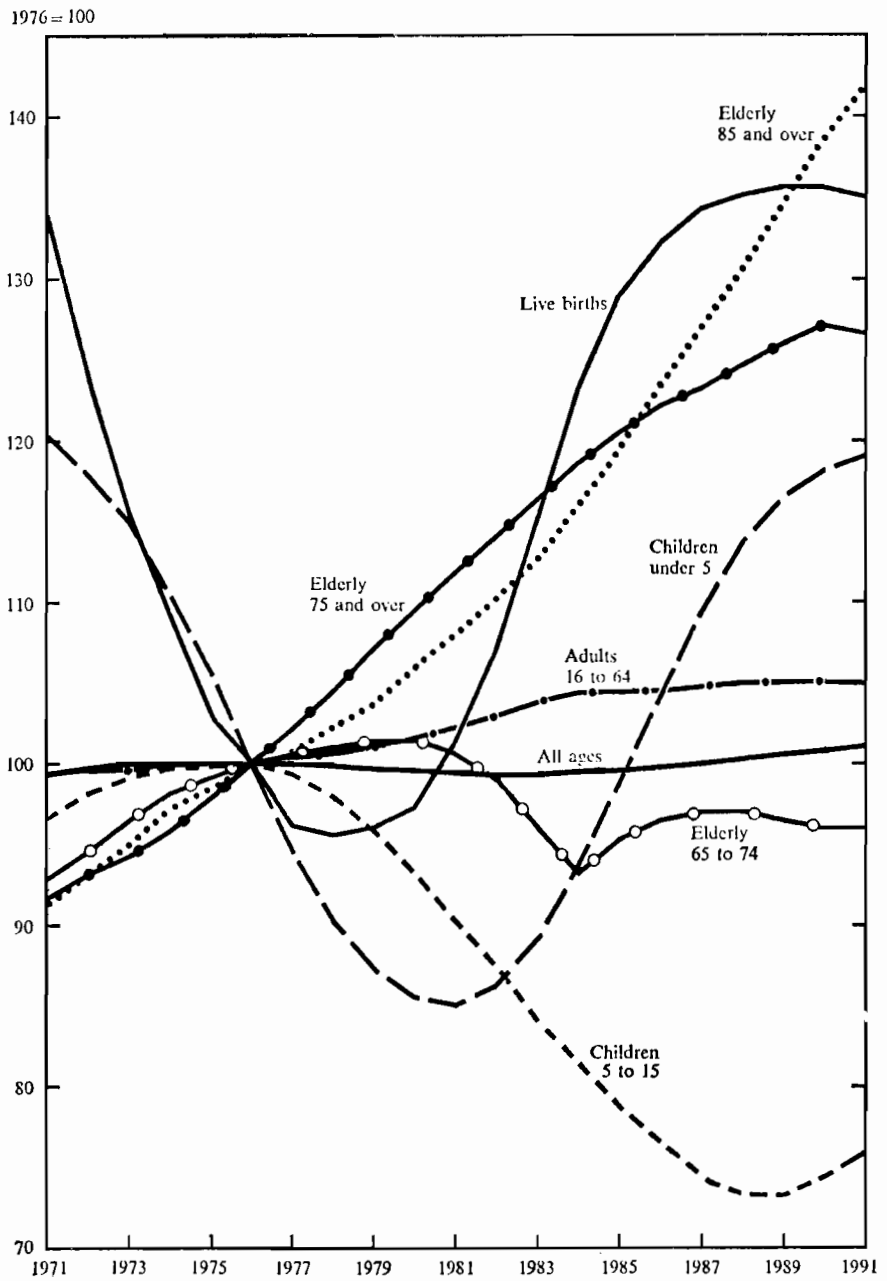

Figure 5. Population changes in England, based on 1976 projections.

Source: [7]

Table 1. Current expenditure per capita by program and region.

Source: [7]

Hospital and community health services 1975/76: £ November 1975 prices												
Population unit	General and acute care (total resident)	Primary care (total resident)	Elderly (65 and over)	Mental illness (total resident)		Mental handicap (total resident)		Children (under 15's)	Maternity (total births)	All expenditures		
				8.4	7.4	3.2	2.9			8.0	300	Total resident
Northern	32	1.4	51	8.4	3.2	8.0	300	61	59			
Yorkshire	32	1.3	53	7.4	2.9	7.0**	300	61	61			
Trent	26**	1.3	50	6.2	3.6	7.0**	290	53**	56**			
E. Anglia	31	1.0**	46	7.0	3.3	7.1	290	58	60			
N.W. Thames	44*	1.9	43	9.3	4.1	9.9	350	76	78*			
N.E. Thames	44*	2.3*	52	8.0	3.1	9.2	440*	78*	76			
S.E. Thames	43	1.7	44	8.4	3.4	9.0	400	76	74			
S.W. Thames	38	2.0	49	11.4*	6.9*	10.0*	320	77	71			
Wessex	30	1.3	44	7.9	2.8*	7.9	260**	57	60			
Oxford	30	1.7	64*	5.5**	3.1	8.3	380	59	71			
S. Western	29	1.3	41**	7.4	5.1	7.3	400	60	61			
W. Midlands	30	1.5	56	6.6	2.8**	8.2	320	58	60			
Mersey	36	1.3	54	9.2	3.2	8.4	360	67	63			
N. Western	35	1.5	47	6.1	3.1	8.2	290	62	56**			
ENGLAND	34	1.6	49	7.7	3.6	8.2	340	64	64			

\* = Highest

\*\* = Lowest

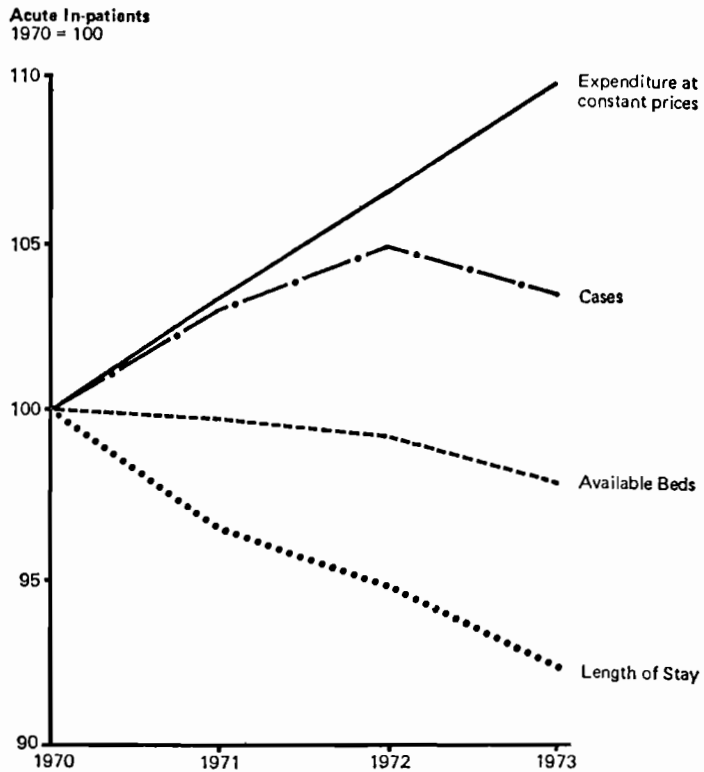

The fall in the number of acute cases in 1973 may have been influenced by industrial action in that year.

Figure 6. Expenditure, cases, available beds, and length of stay for acute in-patients, 1970-1973.

Source: [6]

the number of beds by about 0.7 percent a year, a decrease in the average length of stay by 2.6 percent a year, and an increase in average treatment per in-patient of about 2 percent a year.

Figure 7 reveals a decrease of 5 percent a year in the number of births between 1970 and 1973, and decreases in the numbers of in-patient cases (1.6 percent a year), out-patient attendances (2.6 percent a year), number of beds (marginally), and the bed occupancy rate (average 72 percent in 1970 to 65 percent in 1973).

This suggests, for example, a particularly thorough examination of the use of resources in these two services aimed at:



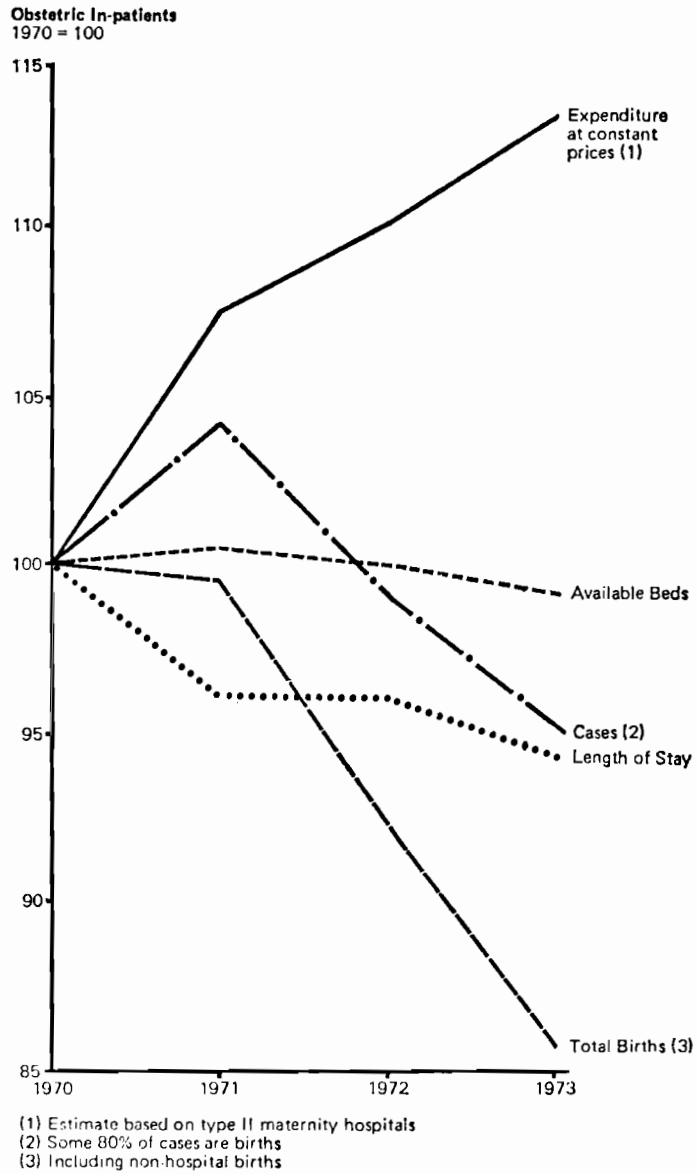

Figure 7. Expenditure, available beds, cases, length of stay, and total births for obstetric in-patients, 1970-1973.

Source: [6]

(1) releasing resources for the development of priority services (such as those for the mentally ill and handicapped and elderly as described above); (2) securing redistribution of resources in keeping with the RAWP report; (3) containing expenditures in the face of the continuing general constraints on public expenditure; and (4) most importantly, permitting the necessary development of new initiatives across the whole field of medical practice.

The Minister was greatly assisted in setting the national objectives by the Balance of Care Model devised by the Operational Research Service. This helped him disentangle past trends, present facts, and future projections, and separate the underlying policy assumptions from expenditure patterns. This model provided a useful tool in enabling the Minister to settle his priorities and promulgate provisional objectives for the NHS in March 1976 [6], in answer to the question "Where do we want to be?".

#### Reviewing National Objectives

NHS drew up strategic plans in keeping with the national objectives. DHSS analyzed the plans by reference to five general questions:

1. Has adequate account been taken of national policies and priorities as set out in the national guidelines?
2. To what extent do regional plans, taken together, produce an acceptable national strategy, and how much is this consistent with central government guidelines? How much do NHS policies need amendment, and how much should central government press RHAs to amend their plans?
3. Are RHAs planning to move toward financial and service equality between their AHAs and the Health Districts
4. Are RHA plans likely to be capable of achievement within financial, manpower, and other constraints within the planning time-scale?
5. Is there consistency between the proposals in the RHA plans and the known RHA capital program and the likely national availability of capital?

These general answers were supported by analytical material relating to each individual region and the national picture. The aim was to tackle each question at four levels: (1) national aggregate answer; (2) national range of variation, that is, the range of variations between RHAs; (3) for each of the RHAs, a regional aggregate answer; (4) for each RHA, an illustrative indication of the extremes of variation.

Each answer related to three points: the present, midway through the strategic planning period (five to seven years ahead),

and the end of the planning period (10 to 15 years ahead). This enabled the DHSS to reconstruct Table 2 on a more realistic basis, to help the Minister set slightly revised national objectives for the NHS [7], and to set out the national average levels of provision and current expenditure per capita for each of the main services offered by Health and Personal Social Services (see Tables 2 and 3).

It also permitted DHSS and NHS to agree on a statistical checklist of information required for strategic planning purposes to assist consideration and comparison of the next sets of national objectives and RHA strategic plans resulting from the next stage of the planning process in the DHSS and the NHS. After receiving and analyzing revised RHA strategic plans next year, strategic plans will be reviewed every four years. Additionally, each year we shall receive and analyze an annual planning report as a means of monitoring the operational plans developed and approved by the NHS against the strategic objectives set nationally by the Minister. At this point, the planning and resource allocation processes are fused into one process designed to secure and regulate an acceptable and agreed approach by the NHS toward the agreed national objectives. The outcome of this endeavor should reflect improved decisionmaking, more effective use of resources, fairer sharing of resources, and, hopefully, an improved level of health by the nation as a whole.

We have, therefore, reached a stage where we will need once again to rely heavily on advice and assistance from our Operational Research Service, which played a vital part in the analytical process described above, in devising suitable models to guide the further development of our planning and resource allocation process.

#### CONCLUSION

The real key to successfully developing and applying the HCS modeling processes described above lies in carefully blending essential interests in pursuit of a clearly defined and accepted goal. In England, we chose to blend the contributions of the statistician, economist, and operations researcher; the doctor, the nurse, and the social worker; the treasurer and administrator; and the epidemiologist. Equally important was the blend of general disciplines: the political and policymaking requirement, the academic approach, the professional discipline, and the administrative action. But an overriding and invaluable requirement was a clearly stated and accepted general objective, strongly backed by central government [8] and set against a tight deadline. There are many possible permutations in deciding on the provision of the academic approach and the professional discipline, depending upon the country and health care system in question and the desired objectives, but for this contribution to be relevant and effective, it must be related to the political and policymaking requirement and its implementation must be secured through administrative action. In short, for any such method to be sensibly developed and successfully applied there must be multiprofessional teamwork.

Table 2. Hospital and community health services: average levels of provision and current expenditure per capita.

Source: [7]

Service	Population base	Level of provision (per 1,000 appropriate population)		
		Departmental guidelines	1975/76 out-turn	1979/80 illustrative projection
Available beds				
Acute in-patients	Total	2.8	3.4	3.1
Acute out-patients	Total	—	...	...
Obstetric in-patients	All births	—	37.6	32.8
Obstetric out-patients	All births	—	...	...
Geriatric in-patients	65 yrs. and over	10.0	8.5	8.4
Geriatric out-patients	65 yrs. and over	—	...	...
Younger disabled in-patients	15-64 years	—	0.04	0.06
Mental handicap in-patients	Total	0.68	1.2	1.1
Mental handicap out-patients	Total	—	...	...
Mental illness in-patients	Total	0.5	2.1	1.9
Elderly severely mentally infirm in-patients	65 yrs. and over	2.5-3.0		
Mental illness out-patients	Total	—	...	...
Places				
Nonpsychiatric day patients	65 yrs. and over	2.7	1.1	1.0
Mental illness day patients	Total	0.65	0.29	0.36
Elderly severely mentally infirm day patients	65 yrs. and over	2.0-3.0		
Ambulances	Total	—	...	...
Other hospital	Total	—	...	...
Staff (WTE)				
Health visiting	Total	0.33	0.15	0.18
District nursing	Total	0.40	0.25	0.32
Midwifery	All births	—	...	...
Prevention	0-4 years	—	...	...
Chiropody	65 yrs. and over	—	...	...
Family planning	15-64 years	—	...	...
School health	5-15 years	—	...	...
Other community health	Total	—	...	...
Administration	Total	—	...	...

... = Not applicable

— = No guideline

WTE = Whole time equivalent

(November 1975 prices)

Throughput		Cost per unit of provision		Expenditure per head of population	
1979/80		1979/80		1979/80	
1975/76 out-turn	illustrative projection	1975/76 out-turn	illustrative projection	1975/76 out-turn	illustrative projection
Cases per bed		Cases			
		£	£	£	£
24.3	28.2	315	318	25.7	27.5
...	...	...	...	6.6	7.0
32.8	37.5	217	201	267.1	248.0
...	...	...	...	35.3	39.6
3.6	3.8	1,120	1,160	34.0	36.6
...	...	...	...	0.20	0.22
Occupancy rate		Occupied beds			
79%	85%	4,370	4,730	0.15	0.23
92%	92%	3,340	3,810	3.6	3.8
...	...	...	...	0.004	0.004
87%	86%	3,810	4,700	7.1	7.6
...	...	...	...	0.35	0.37
		Places			
...	...	1,530	1,530	1.7	2.0
...	...	1,050	1,050	0.30	0.38
...	...	...	...	2.0	2.1
...	...	...	...	2.9	3.1
		Staff (WTE)			
...	...	6,000	6,000	0.88	1.1
...	...	6,000	6,000	1.5	1.9
...	...	...	...	41.5	43.9
...	...	...	...	3.5	4.9
...	...	...	...	1.7	1.9
...	...	...	...	0.37	0.43
...	...	...	...	5.8	6.0
...	...	...	...	1.1	1.1
...	...	...	...	3.8	3.7

Table 3. Local authority personal social services: average level of provision and current expenditure per capita.

November 1975 prices

Service	Population base	Level of provision (per 1,000 appropriate population)			Occu- pancy rate	Cost per occupied place, available place, meal or staff		Expenditure per head of population	
		Departmental guidelines	1975/76 illustrative out-turn	1979/80 projection		1975/76	1979/80	1975/76	1979/80
<i>Residential</i>									
Elderly	65 years and over	25.0	18.1	17.9	95%	1,210	1,290	20.8	21.9
Younger disabled	15-64 years	—	0.45	0.46	95%	1,210	1,290	0.52	0.56
Mental handicap-- adults	16 years and over	0.78	0.28	0.35	95%	1,240	1,310	0.33	0.44
Mental handicap-- children	0-15 years	0.44	0.17	0.24	86%	3,240	3,440	0.47	0.71
Mental illness	Total	0.19-0.30	0.10	0.12	90%	920	980	0.08	0.10
Children	0-17 years	—	3.5	3.9	84%	3,340	3,730	9.7	12.1
Day care	65 years and over	3-4	2.6	2.7	...	Available place	560	1.5	1.5
Elderly	15-64 years	—	0.59	0.63	...	560	560	0.33	0.36
Younger disabled	Total	1.5	0.77	0.97	...	720	740	0.56	0.72
Mental handicap	Total	0.60	0.10	0.19	...	560	560	0.06	0.11
Mental illness	0-4 years	—	8.3	10.8	...	1,010	1,010	8.4	10.9
Day nurseries	65 years and over	12.0	6.5	7.1	...	Staff (WTE)	2,210	14.3	15.7
Other services	Total	—	0.44	0.49	...	4,590	4,690	2.0	2.3
Home helps	65 years and over	—	119	132	...	Meal	0.34	2.1	2.3
Social workers	0-17 years	—	...	...	...	...	...	1.2	1.3
Meals	Total	—	...	...	...	...	...	0.26	0.27
Boarding out	5-17 years	—	...	...	...	...	...	0.08	0.17
Aids, adaptations, etc.	Total	—	...	...	...	...	...	0.59	0.58
Intermediate treatment	Other LA services	—	...	...	...	...	...	2.5	2.6
Administration	Total	—	...	...	...	...	...	...	...

... = Not applicable — = No guideline WTE = Whole time equivalent

REFERENCES

- [1] National Health Service, *National Health Service Act, 1977*, Her Majesty's Stationery Office, London, 1977.
- [2] Department of Health and Social Security, *The National Health Service Planning System*, London, 1976.
- [3] Department of Health and Social Security, *Sharing Resources for Health in England, Report of the Resource Allocation Working Party*, Her Majesty's Stationery Office, London, 1976.
- [4] Department of Health and Social Security, *Better Services for the Mentally Ill*, Cmnd. 4683, Her Majesty's Stationery Office, London, 1975.
- [5] Department of Health and Social Security, *Better Services for the Mentally Handicapped*, Cmnd. 6233, Her Majesty's Stationery Office, London, 1971.
- [6] Department of Health and Social Security, *Priorities for Health and Personal Social Services in England: A Consultative Document*, Her Majesty's Stationery Office, London, 1976.
- [7] Department of Health and Social Security, *The Way Forward: Priorities in the Health and Social Services*, Her Majesty's Stationery Office, London, 1977.
- [8] Owen, D., *In Sickness and in Health: The Politics of Medicine*, Quartet Books, London, 1976.

THE PLANNER'S REQUIREMENTS FOR HEALTH CARE  
SYSTEMS MODELING: THE DUTCH VIEW

A. van der Werff

DEVELOPING HEALTH POLICY AND LEGISLATION WITH RESPECT TO  
HEALTH CARE PLANNING IN THE NETHERLANDS

Developing Health Policy

In recent years many countries have been paying greater attention to the question of organizing health care as a whole. In many cases, the various services that compose the total complex of health care facilities operate more or less independently of one another. However, there is now increasing awareness of the importance of combining all these elements into one coherent system. An attempt is now being made in the Netherlands to do just this.

The state of medical science and technology in Holland makes it possible to supply extensive services. As adjusted by the indicators of the quality of health services, such as infant mortality, vaccination percentages of babies and toddlers, and life expectancy, it can be said that Dutch health care has attained a reasonable level, which is not always equaled by many other countries that are comparable in other respects to the Netherlands.

Nevertheless, Dutch health care is confronted by serious problems. The costs of health care have increased considerably. In 1968 the total costs of health care were some 5 billion guilders, or 5.5 percent of the gross national product (GNP) at market prices; for 1972 these costs were estimated at some 10.8 billion, or no less than 7 percent of the GNP; and, at the end of this year (1977), the costs will probably reach a level of approximately 23 billion, or almost 9 percent of the GNP [1]. Also, many bottlenecks exist with respect to the structure and functioning and financing of health care. The main problems have been listed as follows [2]:

- The complex of health services lacks functional cohesion, both horizontally and vertically. As a result, the services function independently of one another, which leads to an inefficient use of available staff, equipment, and money. Thus the system of services is obscure, especially to the patient.
- The complex of health services is out of balance at various points. As a result of medico-technical developments



and the financing system of social insurance, on the one hand, curative care and the intramural sector have come to be stressed disproportionately; until recently, the latter was able to expand almost without limit. On the other hand, preventive care and the extramural sector have lagged behind, as has the mental health care sector.

- Cooperation and policy coordination between the executive institutions of health care and the other welfare services is often lacking.
- The present structure of the financing of health care is fragmented and obscure, and in certain cases it does not foster the necessary collaboration between services. Financing passively adapts the existing organizational situations. Thus it does not exert a corrective influence on the coordination of the various services.
- Instruments for cost control, both as a whole and with respect to individual sectors, are inadequate or lacking. This makes it almost impossible to react quickly and effectively to new developments.
- Citizen participation in the development of health care and in the functioning of health services has been inadequately developed.

From this short listing of existing bottlenecks in Dutch health care, the following goals for the future structure and organization of health care were derived:

- Changing the existing complex of health services into a coherent whole that functions as a system and can be controlled.
- Changing the strategy mix by shifting the emphasis from personal curative care toward preventive care.
- Reducing the capacity of the general hospitals for acute care in terms of number of beds, and reinforcing extramural care (primary care, ambulant mental care, and community health care).
- Integrating and unifying the financing system.
- Developing the instruments by which the level and quality of health care can be directed and regulated and by which expenditure can be controlled.
- Decentralizing the administrative system and administrative procedures.

### Developing Legislation

Health care in the Netherlands is almost entirely in private hands. The Dutch health care complex, as it operates currently, can be characterized as an arrangement of private and government services, which until recently have developed virtually autonomously. Health care planning, which is referred to as dispersed planning, is carried out for each component of the health care system. But this type of planning carries with it the danger, as already shown above, that interrelations will not be brought out sufficiently among the various elements of the system. For this reason, duplications and gaps arise, as well as the possibility that the necessary cooperation may be lacking.

This process is reinforced by the rapid development of health care, which does not necessarily lead to better health care. Consequently, the brakes must be applied in the right places, and in this the government has a task. This is also recognized in the Netherlands, where it is now accepted that there must be a certain degree of parliamentary control over health care. This means that effective regulation machinery must be laid down in legislation.

In 1974, the Secretary of State for Public Health (J.P.M. Hendriks) published a memorandum that laid down the basis for the development of regulatory machinery of this kind [2]. This legislation, which has since been developed, is still under discussion (end of 1977). These regulations are concerned with supply, demand, and rates.

Supply will be regulated by the Health Care Services Act, by which "all" health care services will be planned interdependently, i.e., as a system. Demand will be regulated by the Health Care Charges Act.

Until now, supply was legally regulated where this was most necessary, namely, hospital care (1971). The new bill, however, concerns in particular volume of health care, namely, the logistics. The point of departure of this bill is the creation of an effective and conveniently arranged system of integrated services. One way of achieving this is the regionalization of health care. Each region will have its own complete system of services geared to the size and composition of its population. The regional authorities will be given certain powers of their own within a framework determined by the central authorities.

Demand has been regulated to a considerable extent in the social security legislation, as stated in the Sickness Benefit Act of 1964 and the Public Insurance Act for the Heavier Risks in 1967. These acts define the benefits to which the insured is entitled. The Health Care Insurance Act is meant to cover the whole population.

The Health Care Charges Act, which has been submitted to Parliament, is intended to achieve a balanced system of charges, and, by doing so, help control the rising costs of health care.

Meanwhile, the Health Care Insurance Act has been withdrawn. Changes in the Health Care Services Act and the Health Care Charges Act are likely with the arrival of the new government (December 1977), but the objectives will remain in principle the same.

## APPLYING THE GENERAL SYSTEMS APPROACH TO HEALTH CARE

### Relationships Between Major Components of the System

The health care complex in the Netherlands is clearly in a period of radical organizational change that affects all its parts. Realization of the goals stated above requires at least application of the general systems approach, which is now being used by the Department of Policy Development for Health, within the Ministry of Health and Environmental Hygiene, in the Netherlands. But first, this approach, which in our opinion is to be understood as "a way of thinking", will be introduced.

In a rapidly changing environment health care systems should be represented as feedback or open feedback systems. We consider this cybernetic system concept of the health care organization to be built up from an administrative management (sub)system, (regulatory or control unit) and an operating system (processor). The operating system exhibits a specific structure, that is, an organizational configuration of service units. The health care system can thus be defined as a coherent whole consisting of a control unit and a number of service units which are related to each other and to the environment. The relationship between major components in the system is given in Figure 1.

The most important components are the environmental system, the human system, and the health care system. The human system represents the consumers both as a totality and as individuals. The broken line around the administrative management (sub)system and the operating system defines the boundaries of the health care system. Disturbances to health in the human system can arise either in the environment or in the biological make-up of man. The activities of the operating system for the prevention and cure of disease are directed away from the operating system (outputs). For this reason, the human system occupies a central position in the diagram.

The operating system is able to exercise its functions (output functions) through allocation of the means required (resources). The total amount of allocated resources sets the limits of budgets for new investments and current expenditures--total costs should be kept within these limits. The emphasis, therefore, is on economic use of resources. The budgeted inputs, that is, manpower, technology, facilities, materials, and financing (support inputs) enable the health care system to carry out its output functions. Thus the process flow, represented by the incoming and outgoing arrows in Figure 1, is used only in a material sense. The patient flow (input, throughput, and output

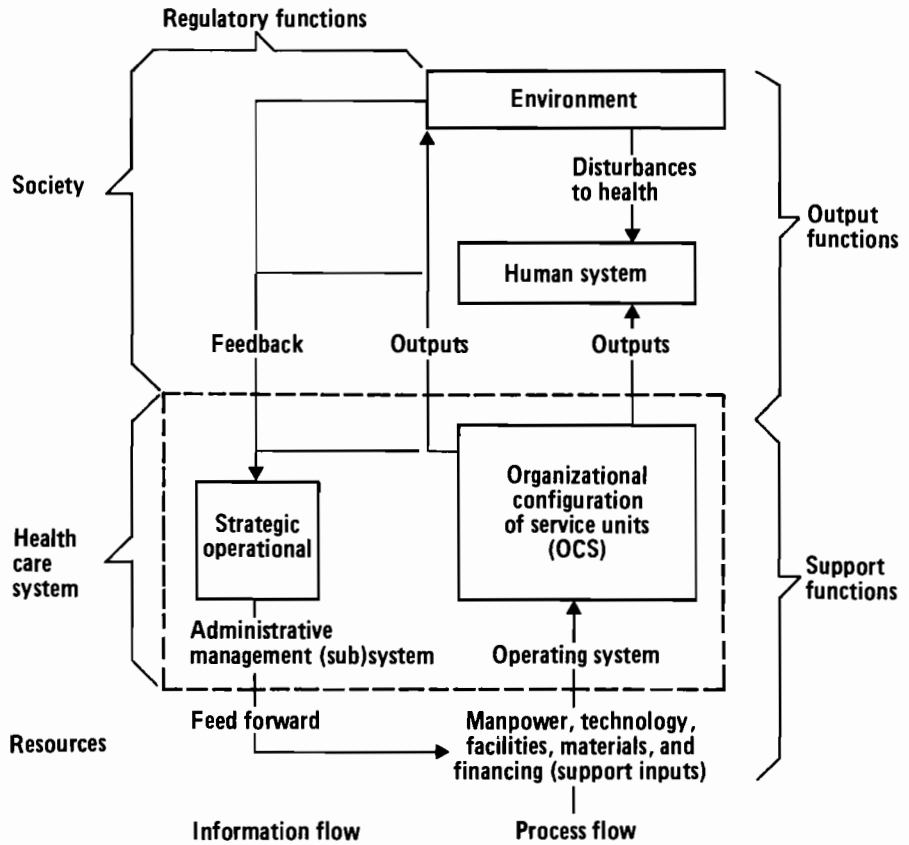

Figure 1. Relationships between major components of the system.

of patients) toward which the functions of the system, at least in part (i.e., personal preventive and curative care) are directed, is of a different order and is therefore considered separately.

The results of all these activities are measured and the information is fed back to the administrative management (sub)-system. The direction of the arrows shows that information is obtained about the functioning of the operating system itself and the effect that these activities have on society, comprising the human system and the environment. This information serves the basis for the control function (feed toward) of the administrative management (sub)system. Thus these arrows in the figure show the information flow. The administrative management (sub)-system defines the functions of the health care system and the relationships between the service units. Through the feedback

mechanism, it monitors the operations of the system and the effects achieved. Furthermore, it monitors the relationship between the health care system and the wider environment of society as a whole. Anticipation of future developments is essential. In this context, the administrative management (sub)system is not dependent on individuals. It is concerned with the regulatory function itself and not with the individual carrying out the function.

To be viable and effective, the health care system must perform several functions: output, support, and regulatory. We will only discuss those aspects of these functions important to our study. The output functions include all the activities that the health care system is required to carry out in society. The support functions enable the health care system to carry out its output functions. And the regulatory functions determine, organize, direct, monitor, and correct the output functions and support functions.

The regulatory functions have both operational and strategic components. The operational component is aimed at continuity, (i.e., running the health care system in its existing form), while the strategic component is aimed at renewing and changing the existing organization when necessary. This contrast between "control" and "staying on course" and "break-through" is an inevitable feature of management. In addition to this contrast, there is also a clear relationship between the two factors. Renewal in the organization is always aimed at improvement, that is, getting the organization to function at a higher level of efficiency. Thus both the strategic and the operational decisions are the responsibility of management.

As part of this regulatory function, the strategic component affects both the output and support functions. The strategic regulatory function comes into its own in the formulation of the future output function(s) of the health care system. The definition of the output function determines the task of the health care system in society. This function can be regarded as a bridge between the health needs of the human system, on the one hand, and the available resources on the other. This output function, which we will call the "health function" as suggested by Reinke, Taylor, and Parker [3], defines the total scope of the activities of the operating system. The support function of the strategic management task will consist of taking the necessary measures for developing the organizational configuration of service units in the desired form.

#### Health Functions

The health functions are specified by the output goals. Such goals must, as the term implies, be expressed in transitive terms, that is, they must be health functions to be fulfilled in the community. An organization can be built up with a configuration most appropriate to these functions and dependent on the available resources.

The specification of the output goals in terms of health functions has two dimensions: (1) ensuring appropriate care for specific needs, and (2) providing health care, that is, choosing the right approach to performing the function. Every health care organization aims at providing personal care for man's somatic, mental, and social welfare. This description expresses the view of man as a system.

In a contribution to a general organizational theory, it can be assumed that health care can be organized in such a way that all people in need of care for whatever health complaints or concerns they may have can be reached. Realization of this general goal will, in fact, be confined to very definite limits. The various factors and relationships that can play a role in determining health functions are shown in Figure 2.

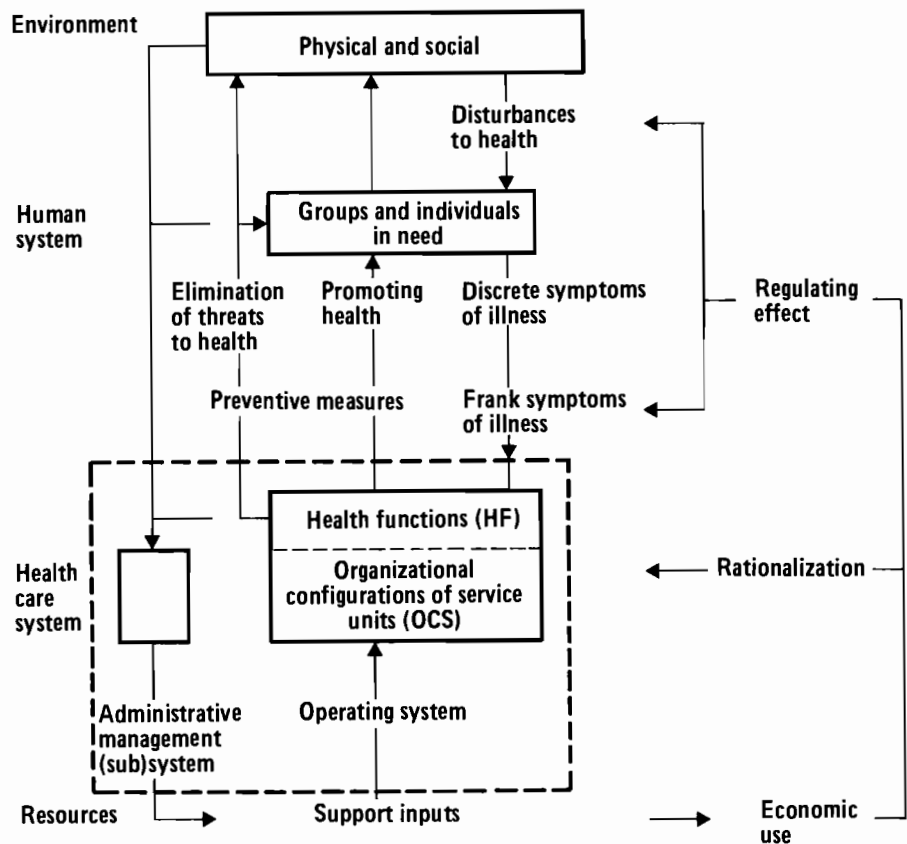

Figure 2. Critical factors in determining health factors.

The operational sector of the health care system, designated the operating system, has the general task of preventing disease by removing the causes--disturbances to health--wherever possible. If health complaints arise from physical and social factors in the environment, or through disorders originating in the biological make-up of man, they must be cured. These health functions are indicated in the diagram by the directions of the arrows.

#### Limiting Costs

One method of limiting costs is, of course, the policy for allocating resources. Once the resources have been allocated, there are in principle two possibilities for their economic use: (1) bringing a certain regulating effect to bear on the health demand, and (2) rationalizing the health care organization.

An important method for realizing the economic use of the available resources is the budget in which the permissible limits are laid down. The possible or permissible extent of the budget depends on economic, social, political, and cultural factors. For the organization itself, it makes no difference whether the budget allocation is a political choice or not. It is, however, important that whatever the size of the budget, an organizational solution is found that will enable health care to be provided to the largest possible section of the population.

#### Organizational Configuration of Service Units

*The Major Subsystems of the Operating System:* Every organizational configuration of service units must be based on the health functions. Once the health function and the way in which it is to be carried out have been defined, the scope of activities and the most important support goals have been determined for the future organizational configuration of the operating system.

As there is wide scope for variation in the choice of health functions, there are many possible variations, both in theory and in practice, in the configuration of the operating system. From the discussion of Figure 2 it appears that the health functions of the operating system have two main aspects: (1) collective care aimed at the community and (2) personal care. The integration of care directed at the community and personal care takes place on the front line of the operating system, namely, in the primary care (sub)system. Specialized community care is concentrated in the community health (sub)system and specialized personal care is concentrated in the hospital (sub)system. Thus three subsystems function as "centers" within the total organizational configuration of service units. These also form the three points of contact within the total configuration (see Figure 3).

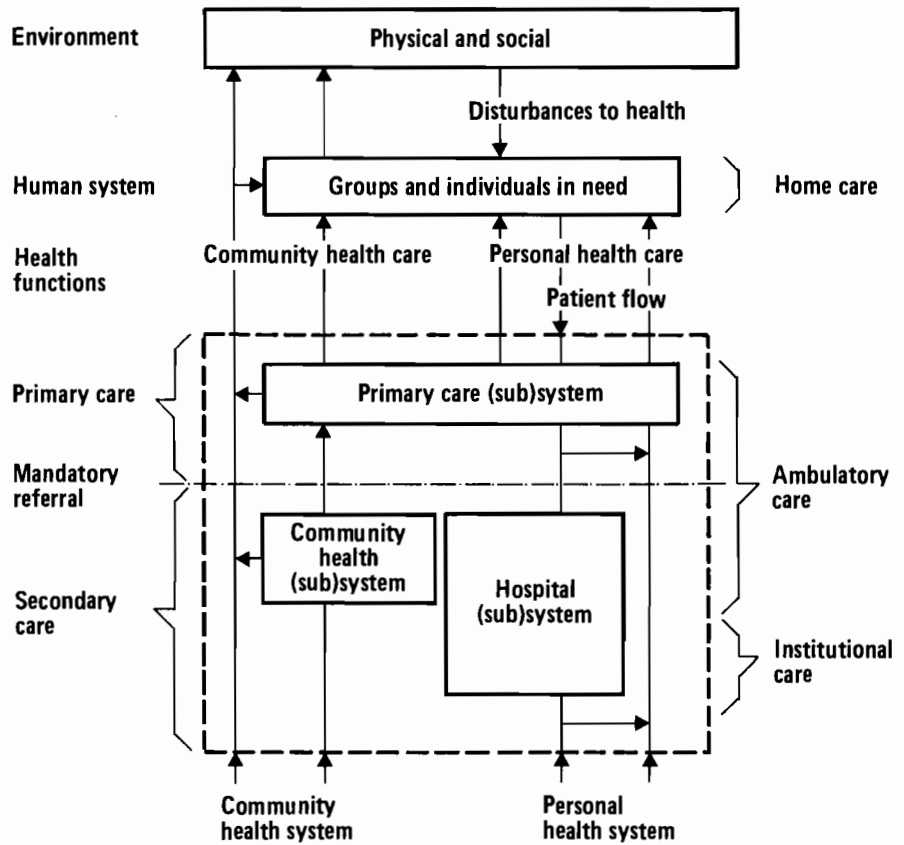

Figure 3. Major subsystems of the operating system of health care, traditional system.

We will now discuss the following in more detail (see Figure 4):

- the vertical and horizontal organization of the hospital (sub)system,
- the organization of ambulatory care within the hospital (sub)system,
- the organization of the community health (sub)system,
- the organization of the primary care (sub)system.



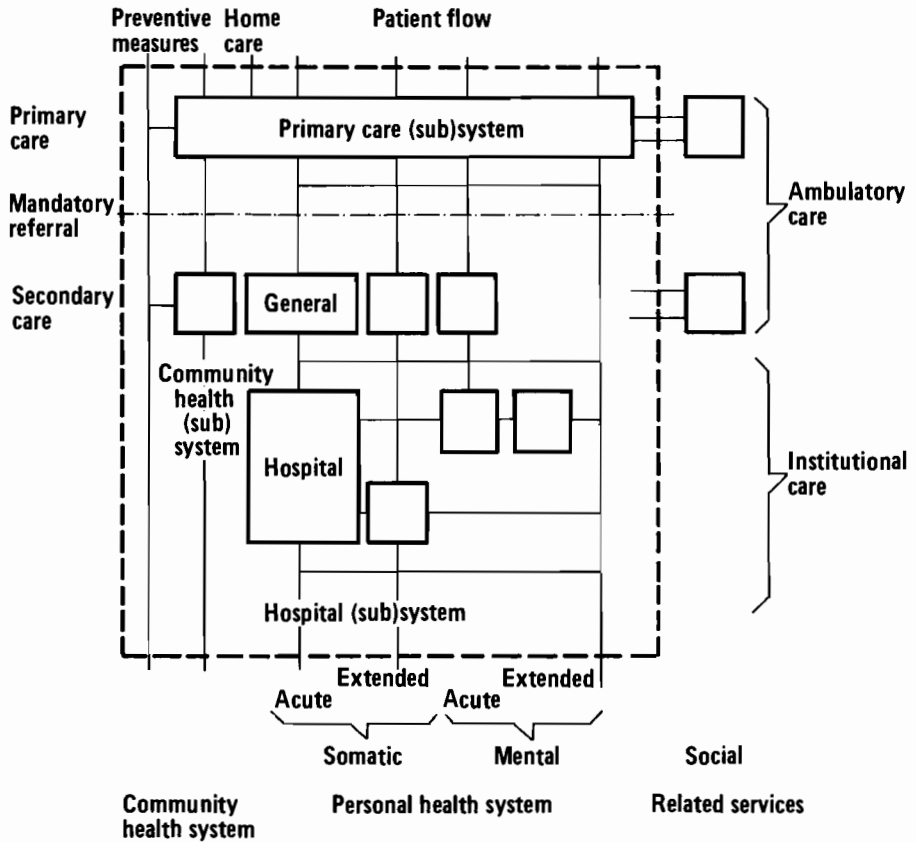

Figure 4. Organizational configuration of service units, traditional pattern.

*The Vertical Organization of the Hospital (Sub)System:* The generally accepted concept of hospital organization is that the various institutions are arranged and interconnected to form a single, cooperative whole. This system must be adapted to local geography and population distribution, on the one hand, and to the specialized branches of medicine and the prevalent diseases in the region on the other. In order for hospitals to be organized, equipped, and adequately staffed with qualified personnel to handle conditions that occur less frequently, they should be located in such a way that they can handle reasonably large groups of the population. Common minor ailments can be treated in less lavishly equipped hospitals at the periphery, which can serve small local groups.

The vertical organization consists of a pyramid of similar (acute care) hospitals that provide a number of specialties. The

base is formed by the local hospitals, which provide the basic specialties for the day-to-day needs of a small, localized group. The second level is formed by the intermediate hospitals, each of which is responsible for an area or district and provide all general specialties. The top hospital provides all specialties. In Figure 4 the local hospitals have been omitted for the sake of clarity.

The vertical division of responsibility within the hospital (sub)system must be planned in such a way that each specialist has a department sufficiently large for the medical and paramedical personnel and not less than the basic equipment that it needs for its economical use. Furthermore, there should be a suitable flow of patients to enable fullest use of the department's resources, but also for an adequate quality of care to be provided. If patients with rare or complicated conditions are referred to these specialized units, there can be economic advantages for the system as a whole.

*The Horizontal Organization of the Hospital (Sub)System:*  
The horizontal organizational consists of cooperation between dissimilar hospitals: general hospitals for acute care, clinical centers for mental care and institutions for follow-up care. In view of the vertical division of responsibilities, the horizontal cooperation of dissimilar hospitals is mainly of importance at the secondary care level. Patients suffering from chronic illnesses and certain conditions which commonly result in some impairment of bodily function or disability often reach a stage where complete recovery is slow or may never occur. Such patients will continue to require care, but not the intensive care provided by the general hospital. It must be possible for these patients to move from the general hospital for acute care (and possibly from a rehabilitation center integrated within the hospital) to institutions for long-term nursing care. It should also be possible to refer patients who have been admitted to a clinical center for mental care to other institutions within the mental health care system for further treatment and recovery. This is, of course, also true for patients who have been admitted to the psychiatric ward of the general hospital. Patients for whom no recovery is possible should be referred to institutions with facilities for permanent nursing (residential care), while patients who can recover should be given care that will help them take part in normal daily life, both in the family and at work (transitional care). All these "horizontal" units should form a functional entity, whose capacity is matched to the patient flow. As in the vertical organization, each specialist should have a department large enough for the necessary medical and paramedical personnel and equipment. There are economic advantages for the services as a whole, as appropriate extended care can be provided more cheaply by these facilities than by the general hospital or the mental center for acute care.

*The Organization of Ambulatory Care within the Hospital (Sub)System:* Only a small percentage of the total number of patients require bed care. For this reason, the traditional health care pattern has always paid considerable attention to the services for ambulatory care, particularly from the point of view of the hospital organization. Ambulatory care can be organized in out-patient departments or day care centers. Greater efficiency in the hospital organization can be realized by examining and treating patients in polyclinics, where possible. In this way, it is possible to achieve an optimal bed occupancy rate and a reduction in length of hospital stay. Furthermore, an out-patient department in the hospital makes it possible to obtain better use of medical/technical apparatus. A large flow of ambulatory patients would also lead to more economic use of the varied and up-to-date equipment and specialized personnel.

*The Organization of the Community Health (Sub)System:* Traditionally, the community health (sub)system has had the tasks of preventing disease and promoting health in the community. The preventive services of the community health (sub)system are directed toward (1) identifying environmental hazards to health, advising on the appropriate measures to be taken, and participating in these measures; and (2) controlling communicable diseases. However, it cannot perform these tasks without the cooperation of the community and the identified groups or individuals in need within it. An important aid to the prevention of disease and the promotion of health is, therefore, health education. This service is based on the health information system which monitors both the environmental factors that could threaten the health of the community, and the progress that is made against disease. The information system should be set up in such a way that it meets the needs of the health care system and is accessible to all health care workers. Thus, it serves to inform both the administrative management (sub)system and the personal health system.

*The Organization of the Primary Care (Sub)System:* At the primary level, the patient enters the health care system whereupon he is referred to more specialized services. Basic health care services are provided and a mechanism is made available for continuing case management and coordination [4]. This system is characterized (according to Fry [5]) by the fact that long-term and continuing care is provided at this level for a relatively small and static population for predominantly minor and chronic disorders. Through the primary care (sub)system health care can be brought physically closer to the community. Its place, therefore, is in the community, where the health care system should be made as recognizable and accessible as possible.

The first-line health care workers must act as the representatives for the whole health care organization. They have a unique observation post and are thus in a position to observe

and affect the physical and social factors that, in a multi-causal combination, play a role in the origin and course of sickness of the people who come to them for help.

Primary care should integrate preventive care and curative medicine. Thus the primary care (sub)system is part of both the community health system and the personal health system (this is expressed in Figures 3 and 4 by the arrows directed toward the human system, indicating prevention, and those directed away, indicating patient flow).

Ambulatory care, organized at the primary care (and secondary care) level, must be completed by the organization of home care. If ambulatory care and complementary home care services function correctly, the result is fewer admissions to the hospital (sub)-system and earlier discharge.

Primary care also has an essential place in making more economic use of the resources of the health care system as a whole. Incidentally, the better the preventive and curative care in the first line, and the fewer unnecessary referrals to the more expensive medical/technical apparatus in the secondary and tertiary care level, the lower the costs of the whole system. Economic advantages can thus be obtained by providing the best possible diagnosis and care at the primary level, coupled with care at home wherever permitted [6].

*Characteristics of the Service Units in the Configuration:*

The primary care (sub)system, community health (sub)system, and hospital (sub)system are each built up from a number of service units. A service unit can be regarded as a team or several teams of health care workers concentrated around a health/technical facility. The characteristics of importance for service units are: their selected tasks, the team configuration, the equipment of the health/technical facility, capacity, threshold value, and relationship with other service units [7].

The task of a service unit is to contribute to the health functions of the health care system, which depends on the technology serving the service unit.

In order for a team to make a contribution to the health functions and to be responsive to the ever-changing environment and health needs, it must have a structure that is both rigid enough for it to carry out its functions and flexible enough for adaptation to extremely variable circumstances [8]. We, therefore, see a team configuration that is built around a fixed nucleus which varies for each of the subsystems. The fixed nucleus of a primary care team will consist of the health care workers who have the closest ongoing relationship with the consumers/patients. The health care team of the community health system will be built up around specialists in community medicine, while in the hospital (sub)system, the fixed nucleus will be medical specialists.

A health/technical facility will be composed of a reception unit, a diagnostic and treatment (therapeutic and rehabilitation) facility, and an information unit. This type of configuration will also be encountered in ambulatory care. In an institutional setting, it will be extended with bed capacity and the associated catering facilities.

The capacity of the service unit may be defined as its ability to meet the demand for care. In addition to the quantitative aspect, capacity has also a clear qualitative aspect which is the level of care to be provided.

The threshold value is the minimum size that is necessary from an economic point of view to ensure the continued existence of the unit. The threshold value and capacity depend on one another, as an optimum quality of care can only be achieved by a sufficient scope of activities and patient load.

*Organizational Change:* Health care services will always be subject to change to ensure appropriate exercise of their health functions in society and maintenance of their organization. This process is accelerated by attempts to reorganize the existing complex into a system. Such attempts often take the form of a comprehensive blueprint of the future configuration of service units, which was also done in the Netherlands, and considerable time and attention is often devoted to this activity. Nevertheless, drawing up such a blueprint is no more than the first step on the road to change; a large amount of organizational activity is also necessary. Further, it is also unrealistic to develop such a blueprint as a final solution in a period of radical organizational change as we experience nowadays. These changes result not only from internal pressures, such as increases in scale, but also from influences originating in the environment, which is also changing. Because implementation of organizational changes can require considerable time, new changes can take place before implementation is complete. This means that environmental factors changing in the course of time must be anticipated in the development of health care systems. This decisionmaking is of a strategic nature.

Organizational change is regarded as a systematic, permanent, and problem-oriented action directed toward developing a total health care organization. In applying a developmental approach, efforts are made to bridge the gap between the existing situation and the desired future concept in a series of steps toward the latter. Organization is directed toward creating room for this process of change. The possibility of choosing a new course for the future and an appropriate new phase of development, on the basis of experience and new viewpoints, is always kept open.

This approach treats organizational problems as a function of time and thus runs parallel to national health planning. The principal difference from planning lies in the fact that the organizational problem itself occupies a central position so that

the permanent action and deep-going influence on the behavior of the organized group that are necessary for effecting organizational changes can be achieved. This approach does not replace national health planning, but it is an essential continuation of it. It is intended to ensure that planning has the desired effect, that is, organizational change. Thus a new dimension is added to planning.

The developmental approach to the organization of health care systems can be divided into four stages:

1. Defining future goals in terms of the necessary health functions.
2. Determining a corresponding future concept for an organizational configuration of service units.
3. Realization of that concept in stages, starting from the existing situation. The first step should lie close enough to the existing situation for realization to be feasible.
4. Planning, implementation, and evaluation of each step (see Figure 5).

To determine the necessary health functions, it is necessary to be aware of the various possibilities. Health functions are determined by strategy formulation that anticipates future developments.

The mix of strategies selected for the future determines the direction in which the organization of the health care system develops. Selection of a particular organizational configuration requires being aware of the various possibilities, that is, use of a whole range of blueprints. This makes it possible to choose a variation that lies close enough to the existing situation for realization to be possible, but nevertheless represents a logical step toward further development.

#### NEW REQUIREMENTS FOR HEALTH CARE SYSTEM MODELING

Now that the development of health policy and legislation with respect to health care planning in the Netherlands has been described, as well as the general systems approach to health care, we will try to formulate some conclusions about what requirements planners might have in the future for health care systems modeling.

#### Application of the General Systems Approach, as a Way of Thinking

The scope of health care planning has become broader over the course of time. In the past, in many Western countries, as is the case in the Netherlands, planning has been limited to

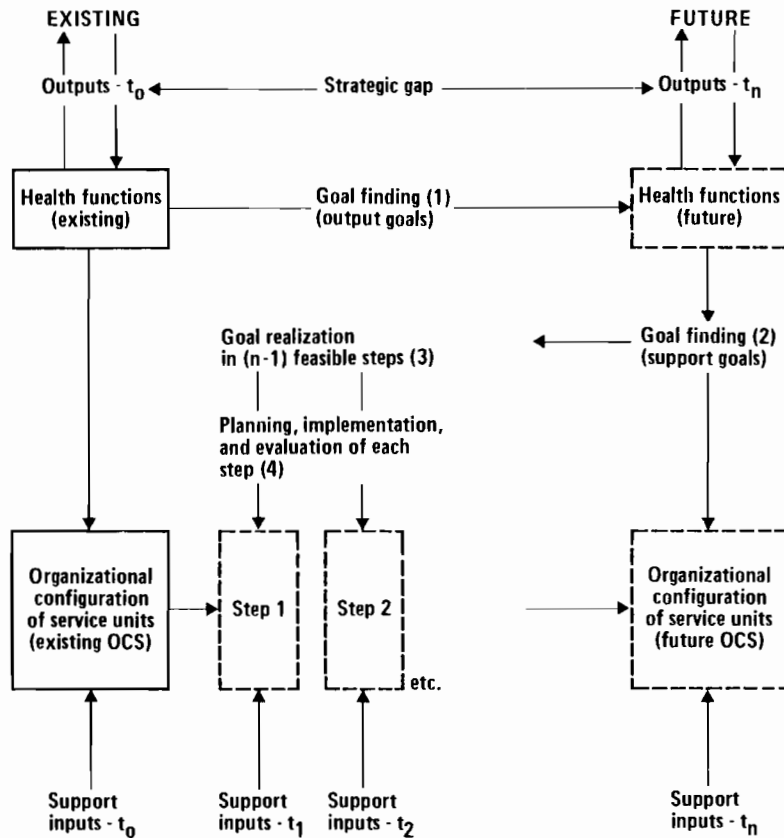

Figure 5. Developmental process of organizational change.

hospitals. But, as the hospital is only one link in a chain of service units, it is difficult, if not impossible, to forecast the effect of reorganizing this component of the health care system as a whole and on costs. For this reason, the partial approach is regarded as insufficient. Now, the planning is being applied increasingly to the whole system.

Furthermore, efforts are now being made to improve the ability of planning methods to bring about organizational changes by taking the behavioral variables, i.e., the qualitative factors, into account. This method of working is expressed in the degree of participation permitted in information processing and decision-making.

Planning, therefore, is not to be handled as a technical process. Quantitative methods, such as mathematical models, might be very helpful, but their effectiveness on organizational

change is limited--an approach that is too technical evokes resistance. Thus health care systems models based on mathematics should not be overemphasized; a systems approach, in general, used as a "way of thinking", is far more important. Mathematical models should be used to illustrate the interrelationships between the different components of the system.

#### The Need for Strategic (Predictive) Models

Decisions about the organization of health care systems must anticipate future changes in environmental factors and consequent changes in health needs and demands. This decision-making is thus strategic in nature. Unfortunately, most models offered to planners are operational in nature, which points out the need for strategic (predictive) models.

#### The Need for Strategic (Simulation) Models

Organizational change must be regarded as "changing the total system". An important reason for reorganizing health care as a whole is the economic factor. From the economic point of view, health care is always indivisible. The introduction of insurance systems has resulted in a gradual change from personal responsibility for the cost of individual care to public responsibility for the costs of health care as a whole. This development led, everywhere, to government involvement in the whole of the health services.

The increasing amount of funds required to cover current expenditures and new investments now comes from a single source, the public. The allocation of funds among the functional service units involved in the health care system can, therefore, be viewed as a single transfer payment, making health care one sector of a whole range of collective services. The percentage of the national income that can be made available for health care comes under the pressure of the government budget, and the allocation depends on health care's priority within the socioeconomic policy of the country. This means that scarce health resources, that is, scarce in relation to demand, must be used as rationally as possible. As indicated above, lowering the cost within the hospital (sub)system for acute care is regarded as the most significant means of reducing costs as a whole. A reduction of the in-patient acute bed/population ratio and a consequent reduction in in-patient services and medical/technical facilities appeared to be principally achieved by substitution: simultaneous expansion of the hospital (sub)system for extended care, the hospital (sub)system for ambulatory care, and the primary care (sub)system (including home care).

Usually health care system models are restricted to very limited areas. Although this is necessary and also helpful to the planner, as we showed above, there is a special need for



models that describe the interrelationships between the components of the total system. In the Netherlands, special attention is given to the development of the so-called "macro-models" [9], which is supported by the Ministry of Health. According to our experience, more emphasis should be devoted to strategic (simulation) models that are related to the totality of the system.

#### A Shift from Mathematical Modeling toward Modeling of Strategies, Organizational Structures, and Information Systems

As we have seen, output goals in terms of health functions express the task that health care systems have to fulfill in society. In the real situation, many different strategies can be distinguished, but it appears that the nucleus lies in the desired effect on demand. Control of demand is directed toward preventing any unnecessary demand that may result in a load on the health care system. This may, to a greater or lesser degree, be left to the personal responsibility (self-care) of the consumers. Various strategies should be explored and worked out in a series of ideal types (or strategy models). From this range, it would be possible to select the mix of strategies most suitable for the expected circumstances [10].

Many possible alternatives exist for the organization of the operating systems, but the right choice can only be made based on a survey of all the possibilities. These variations should be classified and worked out in the form of a number of ranges of ideal types (or structure models). By selecting a combination from these structure models, for every strategy mix and every phase of development, a combination could be found [10]. In addition to this a range of different information models could also be developed (according to Härö).

Thus far the emphasis in health care systems modeling has been mathematical modeling. Because planners are heavily involved in processes of organizational change and are always in need of problem-oriented solutions, attention should also be given to the modeling of strategies, organizational structures, and information systems.

#### Replacing Bed Capacity with "Functionally Defined Service Units" in Health Care Systems Modeling

Traditionally in health care systems models, the "bed" has been used as the planning unit, whereas all other components in the total system are simply costed out in relation to the calculated number of beds. However, when applying the systems approach in planning this method seems no longer adequate. In the Netherlands, replacing the "bed", as a planning unit, with the "functionally defined service units" [9] discussed earlier has been promoted. It is expected that in the future these planning units will prove to be an efficient and adequate instrument to health care systems planners.

REFERENCES

- [1] Ministry of Health and Environmental Hygiene, *Financial Survey of the Health Services*, No. 1, The Netherlands, 1977.
- [2] Ministry of Health and Environmental Hygiene, *Memorandum on the Structure of Health Care*, The Netherlands, 1976.
- [3] Reinke, W.A., L.E. Taylor, and R.L. Parker, *Functional Analysis of Health Needs and Services*, The Johns Hopkins University Press, Baltimore, Md., 1973.
- [4] Parker, A.W., *The Dimensions of Primary Care, Blueprints for Change*, University of California, Berkeley, 1973-1978.
- [5] Fry, J., ed., Considerations of the Present State and Future Trends of Primary, Personal, Family, and General Medical Care, *International Journal of Health Services*, Special Issue, No. 2, 1972-1975.
- [6] van der Velden, H.G.M., *Huisvrouw, huisarts, huisgezin*, Doctoral thesis, Nijmegen, The Netherlands, 1971.  
de Melker, R.A., *Ziekenhuispatient, huisarts, huisgezin*, Doctoral thesis, Nijmegen, The Netherlands, 1973.
- [7] Poeisz, J.J., *Planning van de behoefte aan voorzieningen voor intramurale zorg, Eerste oriëntering in de problematiek van planning op basis van functies*, National Hospital Institute, Utrecht, The Netherlands, 1974.
- [8] Parker, A.W., *The Team Approach to Primary Health Care*, University of California, Berkeley, 1974.
- [9] Rutten, F.F.H., J. van der Gaag, and B.M.S. van Praag, *Het ziekenhuis in de gezondheidszorg, Een econometrische analyse van het gebruik van ziekenhuisbedden*, Leiden, The Netherlands, 1974.
- [10] van der Werff, A., *Organizing Health Care Systems, a Developmental Approach*, Rijksuniversiteit, Utrecht, The Netherlands, 1976.

## USING MODELS AS A TOOL FOR DEVELOPING INFORMATION SERVICES

A.S. Härö

### INTRODUCTION

In principle, the users (e.g., decisionmakers) and producers (e.g., statisticians and data-processing experts) of information agree on the value of being informed, having statistics, etc. Yet often it seems something is still lacking. These users and producers usually do not even speak the same "language", that is, the technical jargon used by statisticians and computer experts is not meaningful to problem-oriented decisionmakers or managers and vice versa.

The limitations of information services become especially obvious when the topics of discussion are models and their information needs. The exchange of information initiates a dialogue that facilitates closer cooperation and mutual understanding. Without this, there is no hope of progress, and advances in the managerial aspects of health services will continue to lag behind the technological advances in the medical sciences.

### WHY DISSATISFACTION?

There always have been, and obviously will be, gaps in the information available for use in planning and formulating policy for health care. Rarely is the available information completely relevant and adequate. Hence, there is no need here to make critical comments and recommendations concerning statistics and related sources of information. These have already been presented at official meetings of WHO and at numerous technical conferences, symposia, expert committees, etc. For example, in 1948, the first World Health Assembly recommended that special committees be established in member countries in order to plan and coordinate vital and health statistics. In 1973, 25 years later, when discussing the value of modern methods of management, the Assembly stressed that what is actually needed is a complete reconstruction of health information systems.

Such a radical recommendation is understandable. However, there is no need for specialists in the field, such as statisticians, to feel that their services are underrated. And the existence of modern methods of data processing and their successful applications outside health care definitely suggest the question: Why do we not have the same?

It should be also kept in mind that expenditures on health are continuously increasing, but it is often difficult to show comparable increasing health benefits for everyone. Under such critical circumstances, a defensive attitude is not the correct strategy, but rather innovations, new attitudes, and better information services for those who decide or participate.

It is primarily up to decisionmakers to indicate what kind of information is needed. The technical experts should participate in decisions concerning methods and related aspects. Often competent managers must handle problematic situations without making systematic, quantitative measurements; taking risks because of uncertainty is one of the elements of management. Furthermore, erroneous decisions are not acceptable if the decisionmakers have not done their best to diminish the uncertainties, in other words, have not asked for the help of information services in due time.

#### Statistics or Information System

What is the difference between statistics and an information system? If the term "statistics" is interpreted very broadly it includes nearly everything that can be covered in this presentation. But the concept of an information system has numerous theoretical and pragmatic aspects that serve our present purpose well.

To many users, the term "statistics" has many negative connotations. They picture tabulated figures that require a massive effort in order to produce usable information. To some others, statistics are more or less identical with applied mathematics, again a field in which most managers and decisionmakers do not feel comfortable. However, the term "information system" is newer and is related to computers and modern methods of data processing. Complete reliability and immediate availability of data are two maxims that can hardly ever be achieved at the same time, and it is not uncommon to find that an information system has obvious weaknesses with respect to both. Particularly valuable is the fact that "information system" introduces the concept of "system", which is one of the key elements of modern management.

#### Some Common Misconceptions

Widespread misconceptions exist concerning information and how it is produced and presented. One of those is the belief that there can be a standardized minimum set of data. This could only be possible if policies did not change and activities were stabilized and standardized, or in other words, the more active and innovative the health policy, the less predictable the information needs.

Generally speaking, the information needs of each organization, each decisionmaker, and each situation are different. Thus

one could not list here important information items based on international consensus. Our aim must be a set of well-understood principles and outlines of a functioning information system that can cooperate with decisionmakers, translate their vaguely formulated statements of information needs into definable tasks, and provide good services to the users of information.

Another common misconception is the belief that it is relatively simple to learn what information is needed and how it is actually used. On the contrary, social scientists as well as pragmatic planners are in complete agreement when stating the opposite. In most cases, decisionmakers are not able to determine what information they really need or can actually use without systematic efforts requiring time and often competent help. Solving such a problem by simply asking "What do you need?" is over-simplification.

A few more misconceptions can be added to this list. Sometimes already-produced data are not seen as important because they have not been used. Undeniably useless data exist but, too, the needs of organizations fluctuate. During quiet periods without major managerial problems, information needs are minimal. However, one must also think about critical situations the organization might have. In such situations, facts that are hardly relevant at other times are needed (for example, relevant to acute manpower problems, financial crises, epidemics, etc.).

#### MANAGEMENT AND INFORMATION

In principle, the organizations functioning in the health field have exactly the same properties as all other human activity systems. Each such organization, if analyzed as a system, has one element responsible for coordinating, controlling, etc. --or, in other words, managing. The formal management unit is not always the real one. Management is primarily based on information and, of course, within this context the term "information" must be broadly defined. A management system can be divided into subsystems, and, at least theoretically but usually also in practice, one unit or component specializes in collecting, processing, analyzing, and presenting data and information--an information system. Its purpose is primarily to serve the management system and ultimately to help the organization as a whole achieve its goals.

#### HEALTH INFORMATION SYSTEM (HIS)

A health information system is the "whole" of all activities intentionally organized to provide the management of health care with information.

HIS can be discussed as a system that has elements or subsystems, but there is no need to analyze all possible relations

and elements. Instead each of the following main aspects of a HIS will be discussed briefly:

- its purpose or goal,
- typical elements,
- the planning of a HIS,
- planning information content.

*Purposes or goals* are central to an organization as a system. The goal of a HIS should be, as previously stated, in principle the same as the organization as a whole. Its practical purpose should be the provision of information that would minimize the uncertainty related to managerial decisions. In theory this is relatively simple but not at all in practice. A difficulty is the fact that formal goals are not always the real goals. Health as a right is, for example, an empty word if there is no interest in knowing how this principle is actually applied. Information services and communication links are indicative with respect to formal and real goals.

Regarding the *typical elements of a health information system*, HIS can be limited to those services traditionally labelled as statistics. Statistics can be disaggregated into different levels. Typically, at the lowest level, reports or forms containing aggregated data gathered from different persons, events, etc. during a certain period are summarized. At the next higher level, the forms are again summarized. Then, national measurements are determined by summarizing regional forms. Such a hierarchy closely follows bureaucratic lines but its main weakness is rigidity. The results are limited to answering those questions which were in mind when the basic form was introduced. Individual data systems (registers, data banks, etc.) apply the opposite principle. Each person, event, etc. is handled separately and the summary is made more on an ad hoc basis. Any possible combination of relevant questions can be answered. Its positive aspect is flexibility. Its negative aspect is that a great amount of information, and correspondingly greater requirements for resources, are needed.

Ad hoc surveys and research are definitely a relevant component of a HIS. Some surveys are statistical by nature, others can be labelled clinical, and the most typical ones are combinations of both. A HIS also enables certain control activities, for example, on the quality of drugs, although some of these could in practice be more correctly defined as the "environment" of a HIS. The ad hoc approach is particularly designed to give answers to a specific problem and usually it gives the most exact response. It can be also the most economic way but there are exceptions, such as when competent researchers are not ready to abandon their other duties in order to introduce a specific study and survey. Usually the ad hoc surveys require much time. In

any case, some possibility for coordinating research activities is vital for a HIS.

Experts and published information are relevant elements of a HIS. Traditionally, management has used experts or informants to collect information. Even at present, personal contacts, reports, and memos are collectively one of the backbones of health management and vitally important for the organization. Published information is also very useful, as it gives comparable examples, provides informal norms, and saves resources for other purposes. However, it is sometimes difficult to use this resource as competent readers are often needed more urgently for other activities.

Data processing and communication, both relevant elements of a HIS, belong to another category. The previous subsystems were oriented to collection of data, whereas these subsystems process and analyze data in order to produce relevant information. The HIS cannot fulfill its purpose without communication, that is, "getting the message across". In this connection, it is not possible to stipulate how a HIS should communicate. If reports are unreadable (e.g., due to mathematical jargon or too detailed tabulations or operationally meaningless classifications), there is no communication and no information system. Actually such situations are common and there is no reason to expect management to highly value an information service or system under such circumstances.

In principle, planning can be applied to anything that is constructed intentionally and the *planning of an information system* is no exception. It must be stressed that this does not mean just planning a unit, or department, or "central office", but something that functions as a "system" and fulfills the expected requirements concerning purposes and services. In 1954, the United Nations published the U.N. Handbook of Statistical Organization [1] which discusses the principles in a way that is quite relevant at present and can be applied to health problems. The only word that could be changed is "statistics", which could be translated into "information system":

The ultimate in centralization is the complete concentration of all statistical activities within a single agency. This completely centred situation cannot be considered a system since it does not take into account the operations of the different offices of the many departments of government. It does not provide the means for consultation with departments, a very necessary aspect of a functioning system. As in decentralization, given some suitable means of co-ordinating, this does become a system which may best fit the conditions of certain countries.

Thus, national statistical systems can range from one where some person or organization has only a watching brief over the statistical activities of numerous bodies, through one

where some person or organization has responsibility for integrating the statistical activities of numerous bodies and for undertaking projects of more general interest, to one where some person or organization has responsibility for administering and co-ordinating all aspects of statistics.

It is not possible to specify the optimum degree of cohesion required among the various statistical units. The kind of system required depends upon the country - upon its culture, its economic way of life, its people. All factors exert an influence or pressure upon the nature of the system required. The best system for any country is that one which takes account of these factors in appropriate measure, giving consideration to all and presenting the proper admixture of co-ordinating authority and delegation of responsibility.

This statement is mainly oriented toward a national structure, but such problems are also found inside an organization. Traditionally, statistical units have been located rather low in hierarchy, which might be justified if their role is limited to routinely producing standard series, but definitely not if the goal is a full range of information services and close cooperation between decisionmakers and information experts. A "system" cannot be managed without communications and a reasonable amount of authority. This also makes it possible to integrate other information interests with legal, financial, and directly managerial activities in such a way that special forms for "statistical" purposes can be avoided.

Planning what data should be collected (*content planning*) is another aspect of development strategy. In principle, those who plan content are the users of information, not the technical experts alone. But, as previously mentioned, it is not easy to know what is needed and how information, if available, could modify our decisions. It is natural to think about information needs starting from decisions (a decision is defined here as any event in which a course of action is selected from available alternatives). Thus, in principle, decisionmaking is a process that converts information into instructions for the system. The possibility of not acting should always be included, which means that, on the basis of the known facts, we decide that there is no reason for action. This is correct if we know that no change is justified. However, "laissez-faire" attitude without being properly informed may sooner or later lead to critical situations.

During this meeting, numerous models have been presented, each of which has some special goal in mind. Of course, it would be ideal to have a well-developed and tested mathematical model as the basis for information service planning but in practice it is a slow and impractical way in which to proceed. In this case, the models are not an objective but only a method that may help with the real problem: how to establish what information is needed. The focus is not the formulation of decisions, but only the selection of the information items or indicators needed for forming opinions about the problem. For this limited purpose,



relatively "crude" models are usable, but even these models can only be constructed by persons who know the problem, in most cases, requiring the teamwork of experts. However, valid models cannot be made by someone who is unable to go deep enough, e.g., an expert in statistical methodology only. A model indicates which information is relevant, how exactly something should be known, and what the risks are if we use estimates instead of measurements. If progress can be made in this respect, many difficulties can be solved and the experts in methods and techniques can take part in the dialogue.

For the purpose of simulating real-life situations, only a crude descriptive model is needed. Maybe it is more correct to describe it as "imaginative thinking". Nevertheless, it must be stressed that the decisionmakers and users are the most important group and without their participation the whole exercise is meaningless. Without their help, the other participants do not know which is the critical subsystem and which information is not needed. Outside experts can be useful but, in principle, such experts should come from within the organization and not be visiting consultants. This kind of modeling--simulation activity or something comparable--can be done at any hierarchic level of government.

#### PLANNING AND INFORMATION SERVICES

In the previous discussion, information services are described as serving management and decisionmakers directly. This is correct, but it does not describe the process in detail. Actually, decisions are always preceded by some form of planning, ranging from very formal and elaborate planning to minimal planning. And, by definition, any planning incorporates evaluation, in most cases evaluative considerations of the real-life situation and expectations. It is natural that stressing any of the elements of this continuous evaluation-planning-decisionmaking cycle reveals the shortcomings of information systems. It is not accidental that planners, in particular, are demanding better information because planning without information tends to be an academic, sterile exercise.

There are two main types of planning: (1) planning for something that, at least relatively speaking, is new, and (2) planning to improve or control something already existing. A traditional example of the first is building construction but relevant to this report are all health programs aiming to solve, at least temporarily, a defined problem. These two different types of planning are based on different "models" and *require different types of information*. The "goal-attainment model" is interested in effectiveness, which can, for example, be based on epidemiological measurements. For many practical management purposes, however, a "control model", which focuses on efficiency and on the correct use of resources, is at least as relevant. Finance, personnel, services produced, and other measurements,

uninteresting to an epidemiologist, are valid indicators in this model, which basically describes the activity as a continuous service to be controlled. In real life, both these kinds of planning aspects are usually influential but to a varying degree. The control model tends to refer to a static pattern of activity. The more goal-oriented way of planning is typical of a society or of an organization aimed at introducing innovations.

Within planning there are also "strategic", "tactical", and "operational" plans, each of which serves very different decisions and, accordingly, requires different information. If the goal is to organize information services for national strategic health plans, the team that analyzes and stimulates must be composed accordingly. It is not possible to give any more details here on these three types of planning, but they should be kept in mind in any analysis of the system and situation and for any modeling.

#### CONCLUSION

Information systems should be evaluated as "systems", keeping in mind the "whole" as well as its elements. The ultimate criterion is how well a HIS is supporting decisions: in other words, how much better decisions have been made due to information services. This is not an area in which one can calculate cost-benefit ratios or anything else exactly measurable. In most cases, the satisfaction of all participants, both the formal and informal decisionmakers, is indicative.

A properly functioning HIS should be flexible, taking into account not only what is happening presently but what is also possible in the future and modifying its activities accordingly. Modeling, simulation, and related activities should be carried out continuously. Routinely collected series can be, and usually are, valuable to some few experts but we cannot serve present needs and especially future ones without finishing some series and using limited resources on more relevant purposes.

A properly functioning HIS does not necessarily mean large investments and a great number of people. Yet everything is relative and without resources very little can be done. We are convinced that there are very few other areas in the health field where relatively small investments pay back so well. What we need is mutually shared understanding, interests, and responsibilities.

#### REFERENCE

- [1] United Nations, *U.N. Handbook of Statistical Organization, Studies in Methods, Series F, No. 6*, United Nations, New York, 1954.

## DISCUSSION

The discussion on planners' requirements for models was opened by Dr. Atsumi, who asked if the systems analysis techniques being developed by IIASA were geared to the problems of industrialized or developing countries. Dr. Shigan replied that up to now the focus has been on developed countries because of the composition of IIASA's National Member Organizations. He stated that perhaps in the future models developed at IIASA could be applied to less advanced nations; techniques for estimating morbidity may be especially valuable in countries lacking good health statistics. Finally, Dr. Shigan mentioned that the World Bank is interested in extending the application of systems analysis techniques to all nations of the world.

Dr. Weiss expressed his interest in better understanding the interaction between political and analytical processes. He asked Dr. Graham to explain the genesis of the British government's decision to study the allocation of health services on a geographic basis. Did the collection of information spur a political decision to make a detailed study, or vice versa? Dr. Graham explained that there should be feedback between political policy statements and analysis. In the UK, politicians recognized that there was a need for equalizing access to care, which was the impetus for using strategic analytical teams to clarify exactly where the disparities were occurring. When the nature of the disparities were better understood, the politicians could identify the real issues at hand.

Dr. Gibbs then mentioned that he was worried about Dr. Van der Werff's statement that there is a need for many models to aid policymakers. He wondered if this means that different types of data should be used in test runs of a given model. Dr. Gibbs emphasized that it is important to test the validity of models with historical data. Dr. Van der Werff then distinguished between "statistical models", "preventive models", "curative models", and "organizational models". He explained that a variety of models is needed for organizational planning; for purely prospective purposes, many types of data can be used in the same model to test different policy options.

Dr. Hartgerink likened the task of modelers to that of fishermen "hooking politicians with worms". He described models as instruments that give battle signals, or more literally, statistical signals that something has gone wrong. Dr. Hartgerink then asked Dr. Graham what constituted the real incentive to start modeling in the UK.

Dr. Graham replied that important structural changes had occurred in the UK before the initiation of the modeling activities.

The governing party had produced a national health survey and levels of care had increased. These developments underlined the need for rational procedures for meeting demands and containing costs.

Dr. Van der Werff then told conference participants about the Dutch program for improving health services. A government document pointed to the following problem areas in the health care sector: a need to contain costs, lack of functional cohesion, fragmentation of financing, lack of cooperation between health and welfare agencies, and the unnecessarily large capacity of in-patient services. Dr. Van der Werff explained that it is the recognition of such problems that spurs change.

Dr. McDonald agreed that analysts enter into the planning process when planning agencies recognize specific problems. Thus the general climate must be that change is desirable. Modeling gives decisionmakers a feel for the possible consequences of their decisions and allows them to explore the areas where choices can be made within the many constraints they face. In the UK, interest in new analytical techniques began in 1970 as a consequence of a major reorganization of the Civil Service. Dr. McDonald concluded by noting that political changes in the governing parties do not affect the basic questions with which modeling is concerned.

Dr. Asvall mentioned the difficulty of inducing entrenched bureaucracies to change. In his opinion, small changes are often useless, for they just provoke argument; on the other hand, really radical measures can lead to effective improvements. He cited Norway as an example. There planning had been completely unstructured. After Parliament gave permission for a major reorganization, it took only one and a half years to implement a new planning process. The innovators stepped on the toes of important actors in the health care field, but the former were careful to grant new privileges in return for concessions. For instance, the medical profession agreed to the reorganization because it was allowed to make inputs into the planning process.

These comments prompted Dr. Hartgerink to argue that, on the contrary, radical changes tend to postpone the resolution of problems. Real revolutions are followed by decades of reorganization during which there is little time to deal with such problems.

PART V

Collaboration with National and International Centers



ASPECTS OF COLLABORATION BETWEEN IIASA AND WHO  
IN HEALTH CARE SYSTEMS MODELING

N.T.J. Bailey

INTRODUCTION

This paper is intended to serve as background material for the discussions on the future of collaboration between IIASA and the World Health Organization (WHO) in the area of health care systems modeling. The views expressed are my own personal opinions, but, as the WHO staff member responsible for liaison with IIASA, I have naturally reflected the interest WHO has in research work carried out at IIASA and its possible implications for WHO's own program.

WHO'S PROGRAM

WHO's overall program is directed toward meeting the requests made by member states through the series of resolutions passed at successive World Health Assemblies. This overall program is divided into major programs, programs, subprograms, and there are also certain special programs. Individual projects usually appear as components of a subprogram. In addition to this programmatic structure, there is at headquarters an administrative hierarchy of divisions and units responsible for specific areas of the health field. Most of these divisions and units deal in one way or another with the treatment, cure, and prevention of disease as well as with the promotion of positive health. Apart from headquarters, there are also six regional offices which are directly responsible for collaboration with countries in their areas.

This implies a considerable range of responsibility for collaboration with countries in the development and strengthening of health services, having due regard for such aspects as health manpower, health education, health economics, environmental factors, etc. Furthermore, an increasing emphasis is being placed on the special needs of developing countries, and in particular on the establishment of an adequate level and distribution of primary health care.

Multisectoral and multidisciplinary activities are fundamental to such work and involve major managerial and coordinative aspects over and above the basic medical, epidemiological, and public health components. In short, complex interactive systems are being dealt with, whether we like it or not, and better methods of understanding and controlling the behavior of such systems are urgently needed.

In this connection, it should be noted that the Thirtieth World Health Assembly (Resolution WHA 30.40, 1977) has specifically confirmed the need to develop and strengthen health services research, including the more efficient deployment of resources within health care delivery systems. The Advisory Committee on Medical Research, at its Nineteenth Session in 1977, also recommended the formation of a special program in health services research.

#### RELEVANCE OF MODELING TO WHO'S WORK

Improved quantitative methods are urgently required to facilitate the understanding and control of the complex, interactive systems just referred to. If decisionmakers are to make good choices between available strategies, they must have sufficiently accurate predictions of the consequences of any given choice. This implies an ability to make reasonable forecasts of what can be expected to happen in given situations, at least in approximate terms. Good quantitative modeling is urgently needed, but available developments are very much in their infancy. While a good deal of speculative theoretical work has been undertaken by research workers in many countries, the models produced have rarely if ever been validated by a (1) satisfactory statistical fitting to empirical data, and (2) successful prospective forecasting.

WHO's program entails promoting not only the development of efficient health care systems at the operational level, especially in the context of primary health care in developing countries, but also the proper planning of such services in relation to the constraints imposed by and interactions with sectors other than health (e.g., economics, industry, agriculture, education). This work would be facilitated by the existence of a reliable body of quantitative, methodological know-how.

In addition, broad strategic planning, both at the country level in ministries of health and at the international level in WHO itself, requires effective, quantitative approaches to policy analysis. This must be based on sufficiently good (but not necessarily ideal) data and a sound understanding of activities at the operational level. Tested and reliable health care systems modeling is one of the prerequisites for the development of good planning and policymaking.

#### EXTERNAL INPUTS TO WHO'S PROGRAM

Before the modeling described above can be applied to WHO's program, a good deal of goal-oriented research and development is required. This is being actively promoted by the Health Statistical Methodology unit within the division of Health Statistics at headquarters, in collaboration with the many other units, divisions, special programs, and regional offices directly involved in epidemiology, public health, primary health care, etc. at the country level.



Nevertheless, much of the applied research required cannot be carried out in WHO itself because of lack of staff and financial resources. It is, therefore, essential to have close collaborative contact with a number of outside institutions where resources are available to supply certain vital components. A number of aspects dealing, for example, with the mathematical problems of studying the properties of sets of differential equations specifying a given dynamic model of a health system, can be handled by university-based research workers. There are many such intricate technical problems whose solution has direct relevance to practical issues facing WHO. If these problems are correctly formulated by the methodologists in WHO and transferred on a suitable collaborative basis to appropriate academic research departments, valuable inputs can be obtained at a relatively small cost.

In a similar way, research carried out in-depth at IIASA on the modeling of health care delivery systems could have enormous importance for WHO's work. Of course, in this instance the collaboration could be much closer, since IIASA's team in this area comprises many research workers who are working or have worked closely with public health decisionmakers.

#### POSSIBLE FUTURE ROLE FOR IIASA

To some extent, therefore, the situation already exists for close collaboration between IIASA and WHO on health care systems modeling. And there is the possibility of two-way support. While IIASA has greater potential for developing theoretical work, WHO has more direct contact with governments and ministries of health.

However, IIASA's capabilities in promoting applied systems analysis could perhaps be enhanced by developing a program of activities in which a clear identification was made of the roles of modeling (1) health care systems at the basic technical, health delivery level; (2) the broader, interactive, multisectoral systems, with special regard to the interface between health, economics, education, agriculture, etc.; and (3) policy-level operations, where simple, effective methods are required for handling the inevitable constraints, allowing for poor or missing data, and choosing between alternative policies in the face of unavoidable but often quantifiable uncertainty.

IIASA has the specialized technical know-how to develop such work either through its own staff or through contacting its National Member Organizations. WHO has some limited expertise in the areas concerned, but is primarily involved with immediate practical field applications at the country level.

#### CONCLUSION AND RECOMMENDATION

As indicated in the Introduction, this short survey expresses my personal view, but it might be developed to provide a more solid

basis for collaboration between IIASA and WHO. I have concentrated on what IIASA could do for WHO, rather than the converse, which is, of course, for IIASA to elaborate. There does, however, seem to be a good deal of common interest, and I would suggest that the objectives of both our agencies might be attained more effectively if a joint program of work were drawn up and agreed upon. This program would have to set out the requirements of both IIASA and WHO in the area of health care delivery, paying special attention to the wider context of health services research. It would then be necessary to define the technical systems and modeling aspects of interest, on the one hand, and the urgent practical needs of real human populations, on the other. The relevance of modeling to practical applications would have to be clearly indicated, as well as the dependence of actual public health decisionmaking on theoretical insight and methodological techniques. Appropriate staff at WHO and IIASA would have to be identified and a reasonable timetable of activities worked out.

Because of lack of time and space these matters have been sketched out here only very briefly. What is specifically needed is a joint WHO-IIASA task force that would work out such a program for future collaboration in the necessary detail, and in terms that would be acceptable to both agencies.

## COOPERATION WITH THE WHO REGIONAL OFFICE FOR EUROPE

J.E. Asvall

The question of cooperation with the World Health Organization (WHO) Regional Office for Europe (EURO] in the field of health care systems modeling must be seen in relation to that office's general set-up and its health planning activities in particular. As some may know, WHO is the only organization in the UN family that has a truly decentralized structure. The headquarters in Geneva is concerned with WHO's overall policy questions and most of the practical work is done by the six regional offices. As the result of a recent change in policy, this work will now include more health services research than ever before.

The Regional Office for Europe, which is in Copenhagen, covers all countries in Eastern and Western Europe, as well as Algeria and Morocco (i.e., 32 countries with a population of about 860 million). The Regional Director, who is elected by the Regional committee, which comprises representatives from the ministries of health of the 32 member states, and the Director of Health Services supervise the work of about 30 professionals in the Regional Office who deal with the technical programs. The rest of the staff (approximately 215) are translators, administrative staff, etc.

### FOUR MAIN PROGRAM AREAS

The four main services or program areas are: environmental health, disease prevention and control, health manpower development, and strengthening of health services. Each of these four services is divided into five units, each responsible for one program area. Within the service area concerned with strengthening of health services, the health planning and evaluation unit is responsible for planning methodology, and simulation models of the kind we are discussing here must be considered a planning tool. This unit has only two professional staff members--one physician and one economist. The other units, dealing with cardiovascular disease, mental health etc., are also small, anywhere from one to three technical officers. Thus the manpower resources of the Regional Office are quite small, and this governs the amount of work that can be taken on.

An important aim of the health planning and evaluation unit is promoting the use of WHO health planning and evaluation methods within the region's member states and facilitating the adaptation of such methods to European conditions. The key issues are the

relatively sophisticated level of European health services and the rather different type of health priorities in Europe as opposed to developing countries. Also, research in health planning and evaluation in the European countries is followed in order to see where there are interesting developments that ought to influence our thinking and about which we should inform our member states.

Three program areas are used to carry out this program: technical cooperation activities are undertaken if a country asks the Regional Office for assistance with a particular problem. The regional Office and our headquarters in Geneva were involved in the application of the WHO-developed Project System Analysis (PSA) method to child health services planning in Scotland in 1973 and 1975. The Regional Office was also involved in the application of the WHO-developed planning method Country Health Programming (CHP) to national health planning in Algeria in 1975, followed in 1976 and 1977 by more detailed program formulation exercises in health information systems, basic sanitation, occupational health, and maternal and child health/family planning. This year, the Regional Office is cooperating with Spain in a project applying CHP to the formulation of a health plan for the Province of Vizcaya.

In the second program area (i.e., training), we have been organizing general courses in health planning and evaluation for senior planners and health administrators in cooperation with institutes in different countries. These courses began in 1969, have been running on an average of one a year, and are given consecutively in English, Russian, and French. We have also had a series of three special courses in operations research from 1972 to 1976. In addition, a number of fellowships in health planning and evaluation have been provided.

With regard to the third program area, development activities, a series of studies were conducted from 1973 to 1976 in eight countries (four different socioeconomic areas in Europe) looking at their health planning at the regional level. In 1977, we did a study of the health service model in the Gabrovo district in the People's Republic of Bulgaria, which was mentioned at this Conference as a possible area of cooperation for IIASA. For 1970, the Regional Office plans a study on the role of central health authorities in regional health planning. There are also plans to look more closely at different health program areas (e.g., occupational health services) using a CHP type of planning methodology and WHO evaluation guidelines and have a research institute study this planning exercise. Such studies would be aimed at identifying any methodological difficulties encountered, including information requirements and sources (routine statistics, expert opinion, ad hoc studies) as well as indicators for routine evaluation of the program. The work must be done in cooperation with countries interested in doing such studies themselves.

EURO also organizes a number of meetings of a developmental nature. The most important ones coming up in the health planning

field are: a working group on research in health planning and management in 1978, a working group on the design of training in health planning in 1979, a big European conference in health planning in 1980, a working group on coordination of health planning with other socioeconomic and land-use planning in 1981; a working group on medical decisionmaking in 1982; and, finally, a big European conference on health evaluation in 1983.

Looking at the kind of cooperation the EURO program offers within the field we are scrutinizing at this meeting, there could be an interesting possibility for cooperation with regard to the studies I mentioned on specific program areas. Probably one of the major problems facing the designers of mathematical simulation models is that they do not know enough details about the functional relationship between health activities and their objectives or between an activity and the resources spent on it. If we manage to go through one program area per year in quite a detailed way, we would force new answers to several of these questions. It would be interesting to apply the IIASA models to a health program analyzed in this way as one ought to see more clearly those areas in which we can and cannot find an answer to such functional relationships.

We have not yet decided on our main item of discussion at the above-mentioned working group in 1978 on research on health planning. However, before even hearing about today's meeting, we had given priority to the topic the use of simulation techniques in different types of health planning and model building. It may well be that we will concentrate on this, taking stock of the state-of-the-art and what direction research must take.

There are, of course, many other possibilities for cooperation. I have mentioned only the health planning and evaluation aspects of the Regional Office program, but other activities could be considered as well. For instance, in the context of the Gabrovo project and the screening activities going on there, there is a need to design a general screening model whereby one could find better ways of selecting screening tests and deciding the epidemiological cut-off point after which a particular screening test is no longer useful or economical.

I personally think that such clear-cut tasks would be useful areas of cooperation between IIASA and EURO. I am sure that if one were to look closely at the whole EURO program, there would be other problems where such cooperation would be most profitable.

PROVIDING DATA FOR THE MANAGEMENT  
AND PLANNING OF PUBLIC HEALTH

K. Fuchs-Kittowski and P. Gudermuth

DATA COLLECTION FOR MANAGEMENT AND PLANNING

The need to develop the mathematical models and corresponding computer-assisted information systems required for the management and planning of health care has become increasingly urgent. The quality of health care must be raised by determining its requirements and its costs minimized by a purposeful allocation of material and personnel resources. The models prepared within the framework of research at IIASA constitute a start at improving the planning of health care. However, these models have to be quantified step-by-step in conjunction with the preparation of a concept for establishing an adequate information base.

This paper represents an extension of the paper we submitted to the March 1977 IIASA workshop on modeling health care systems (HCS) [1]. Here we discuss the various possibilities for using the data base we have in the GDR which is based on patient records provided by means of the comprehensive electronic data processing (EDP) project, "Outpatient Health Care", or by means of such specialized EDP projects concerning medical fitness and supervision examinations in industry, care for diabetics, cardiac infarction after-care, dialysis and kidney transplants, child and youth health care, among others, as well as by means of screening systems yet to be developed.

Let us now consider the data requirements for the IIASA HCS models as described in IIASA publications. For example, Shigan [2] has described a number of different methods for estimating disease prevalence, all of which depend upon data availability.

It must be noted that providing the relevant health data needed for using models is very difficult and that even the problem of determining the morbidity structure of the population cannot be solved readily due to material, technical, and personnel reasons. For example, data on the incidence of various diseases, or groups of diseases, are essential. Moreover, the morbidity structure of the population, the various stages of disease, and the distribution of the population within the stages of disease may also need to be identified.

In the paper by Shigan [2], the importance of the morbidity structure to planning was stressed, and reference was made to the various ways in which to determine it in different situations. We emphasize here models that collect their data from general statistics, from EDP projects (either existing or to be established), and from the systems involved in health care organization and screening. Obtaining data from interviews can, in our view, be used only in exceptional cases.

In general, the use of models should, in our opinion, not lead to an increase in medical check-ups or to additional data collection, in other words, models of this type should only be used in the GDR in close connection with medical care, within the framework of territorial health care, and using the computer-assisted information systems established for the health care institutions and the territories. The pre-conditions to be established refer, therefore, primarily to the expansion of medical care and screening systems as part of the health care system, and to the further development of medical automated information-processing systems (AIPS).

In order to secure the data base required for identifying general morbidity, the GDR can and must proceed systematically from existing health care and screening systems and from the EDP projects coupled with them. The collection of additional data within the framework of random samples is justifiable only for exceptional cases. In general, it appears advisable to have recourse to a health care organization that already exists for the following reasons:

- A minimization of expenditures (doctors and medical personnel, data-collecting operators, etc.) is feasible only by integrating EDP projects into medical care.
- The quality of computations made on the basis of models depends essentially on the quality of input data. Checks on semantic errors by means of EDP can be handled without great additional expense only by using these data simultaneously in the medical process.
- The necessary check-ups and data collections require a high degree of motivation of both the population and the medical personnel. This motivation is attained only if there is an immediate, recognizable benefit for both citizens and doctors.
- For humanitarian and economic reasons, no additional physical and temporal stress should be imposed on citizens. Only those citizens who, within the framework of a screening program, were singled out because of evidence of disease, and who will receive treatment, should be recorded.

- The values of a number of parameters used in models can only be determined on the basis of computerized data bases.

Consequently, the approach adopted in the GDR toward models is to utilize, or to expand, the already existing health care systems and the AIPSSs coupled with them. In pursuit of this, we aim to raise the efficacy of the models by using the various possibilities of multivariate data evaluation resulting from the use of models. Evidently, use of the models has to proceed step-by-step over several phases (adapting the models to the existing data bases, identifying the appropriate areas for application, etc.), with overlappings between the individual phases or between analyses that must be performed in parallel.

#### EXISTING EDP PROJECTS TO PROVIDE DATA FOR MORBIDITY ANALYSES\*

In the following, we attempt to show how it is possible to use EDP projects in the corresponding models for planning health care. Other possibilities include medical computerized data bases that exist or will be developed, coupled with the existing data bases for the management and planning of public health.

In order to devise and introduce such a system, it appears necessary to thoroughly evaluate the international experience and the experience of the main users. In the GDR, the following projects, which either now exist or are being prepared for introduction, could serve as a data base for determining general morbidity by means of the different models proposed by Shigan.

#### The General Patient Records of the GDR

For about the last 10 years, a general file with complete documentation on every patient has been maintained by means of EDP. It collects all personal data, diagnoses, treatment, and post-mortem findings and periods of stay in clinics. Furthermore, administrative data are being collected, and collection of additional information is feasible. The data obtained are then evaluated centrally and locally. Together with general demographic data of the GDR and data from the unified mortality and birth register (also handled by EDP), it is possible to conduct analyses of morbidity and mortality.

---

\*These considerations are based on papers and discussions conducted with those responsible for the project: Dobbert, Enderlein, Irrgang, Sälzler, Tölke, and Thiele.



### Care for Out-patients

This project was developed for a large out-patient department in Berlin and was put into routine operation. Presently, it is being gradually expanded and used for out-patient clinics in Berlin. In the future, this system may be transferred to district hospitals presently under construction (e.g., in Suhl, Neubrandenburg, and Schwerin).

The collection of the base data is handled by similar means to the general patient file. Apart from personal and administrative data, other data are collected on diagnoses of diseases to be treated and diagnoses of diseases leading to temporary disablement, and duration of disablement. A comprehensive medical follow-up documentation exists for selected groups of patients. In addition to morbidity analyses, it is possible, among other things, to obtain an automated issue of doctor reports, an automated selection and supervision of patients, and an evaluation of unit capacities.

### Dispensary Treatment of Selected Groups

In the GDR, a uniformly organized care system (which provides, for example, a standardized survey of all diseased persons through registration forms) has been in operation for decades for some selected groups of diseases (e.g., tuberculosis, cancer). Registration and supervision by EDP projects are used at present for the following groups of diseases:

- Myocardial Infarction: An aftercare project was developed for these patients which uses data on all patients in Berlin with cardiac infarction who were treated as out-patients (Figure 1). This project, aimed at identification and life-long supervision of patients with cardiac infarction, is presently being introduced in Berlin but will be extended to other districts. Patient-related clinical and paraclinical findings, as well as data on vocational rehabilitation, complications arising in the course of after-care, therapeutic measures, and period of survival, were given special attention.
- Kidney Transplantation and Dialysis: This project encompasses all patients undergoing dialysis in the GDR (Figure 2). Within a preparatory program for transplantation all essential clinical and paraclinical findings are collected. On the basis of these findings and others, the automated selection of a suitable recipient is made by computer as soon as a suitable donor kidney becomes available. This project has been in operation in the GDR since 1974. The stored data can be provided for specific morbidity analyses with no additional expenditures.

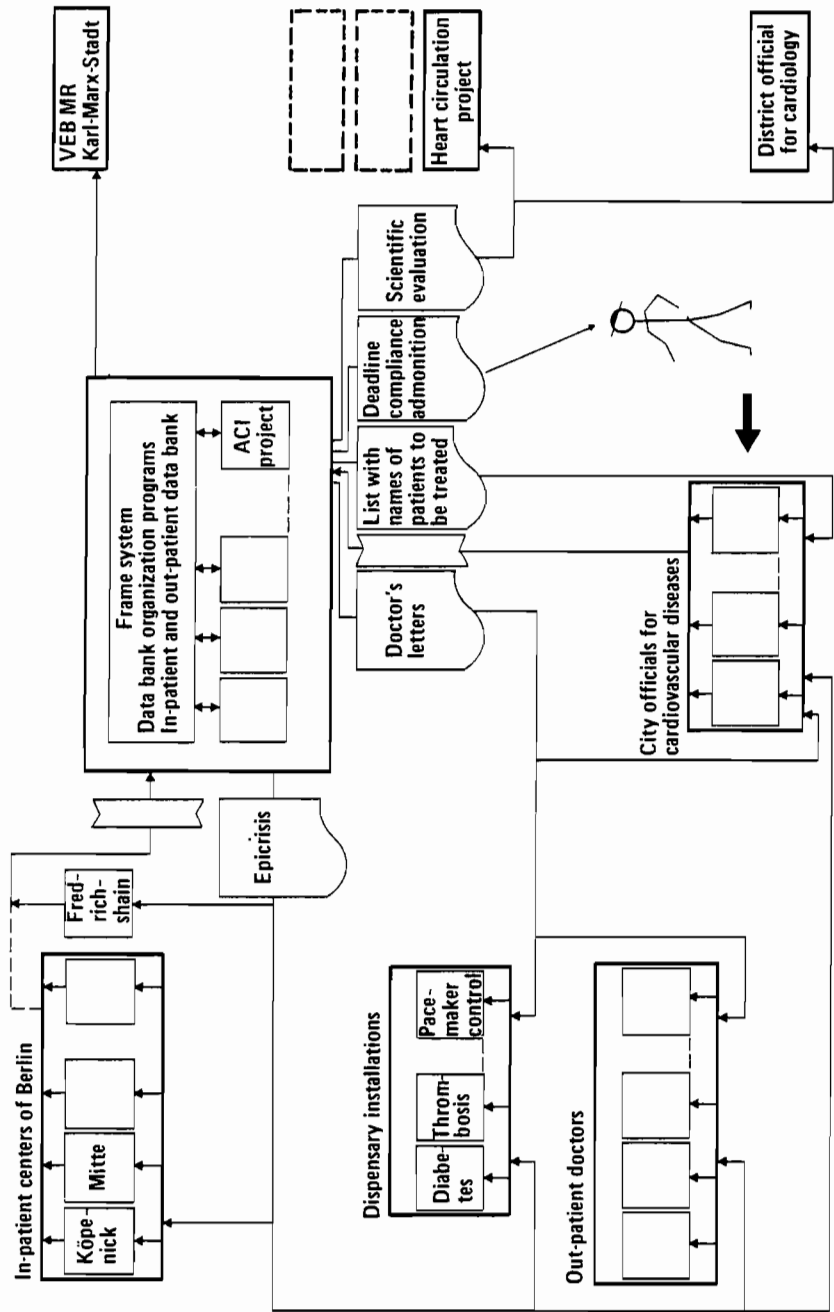

Figure 1. Information flows into the EDP project "FRIEDA" on acute cardiac infarction (ACI).

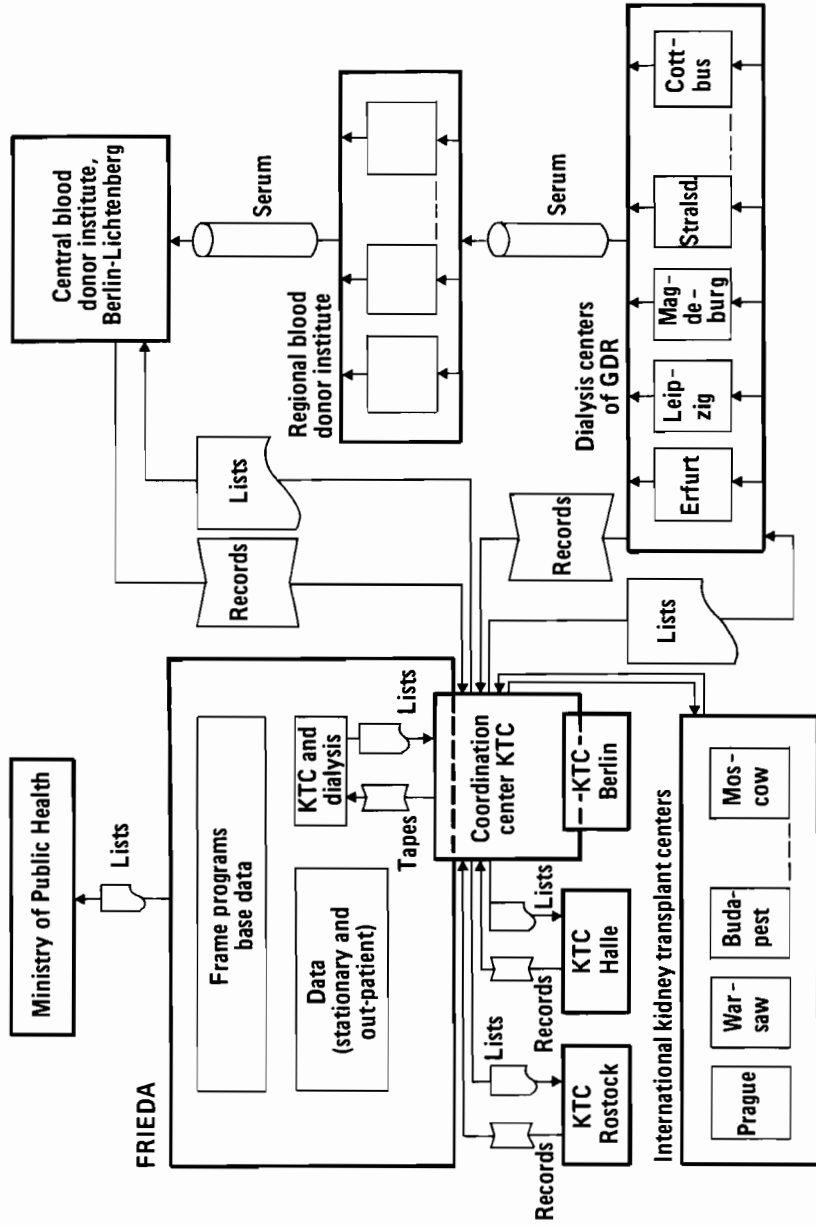

Figure 2. Flow chart of dispensary treatment, dialysis, and transplantation between kidney transplantation centers (KTC).

- Diabetes: This project covers all diabetics in Berlin and may be extended to additional districts of the GDR. Apart from personnel data, data would be collected on case history, stages of disease, and therapy.

These three projects serve essentially to rationalize and improve the quality of health care (for example, by automated reporting on findings and automated selection and supervision of patients). Statistical and scientific evaluations do not require any additional manually operated compilation.

#### EDP Project to Identify and Analyze the Working Conditions

At present in the GDR, some 1 million working people are regularly subject to examinations for their fitness to work in industry. From 1976 through 1978, new instructions on medical examinations are being tested, including a uniform basic check-up. In accordance with the health hazard and specifications of the worker, this basic check-up will be supplemented by additional examinations. A new EDP form is being tested together with the new methodology. Apart from personnel data, information on occupational diseases and hygienic conditions is collected. Data storage and their evaluation will be done separately in each district, but several industries, such as construction engineering, use central storage and evaluation.

#### Evaluation of Data Obtained from Screening Examinations

Work has been started to establish a health care model, based on screening examinations within a limited territory (10,000 to 20,000 people). This model, which will become effective after 1980, fits into the existing structure of health care within the territory in question and takes into account the already effective screening examinations for chronic diseases. Aside from serving as a source of data for evaluating the efficiency of screening examinations, it also serves as:

- an immediate improvement of medical care, e.g., by simplifying and completing follow-up;
- a source of data for scientific research;
- a source of data for decisionmaking by management in this territory (Figure 3).

Existing screening examinations will be extended by means of a new screening center. All results now obtained through examinations are stored in a data bank, and the personnel data in the data bank are updated by means of the data bank of the inhabitants' territory.

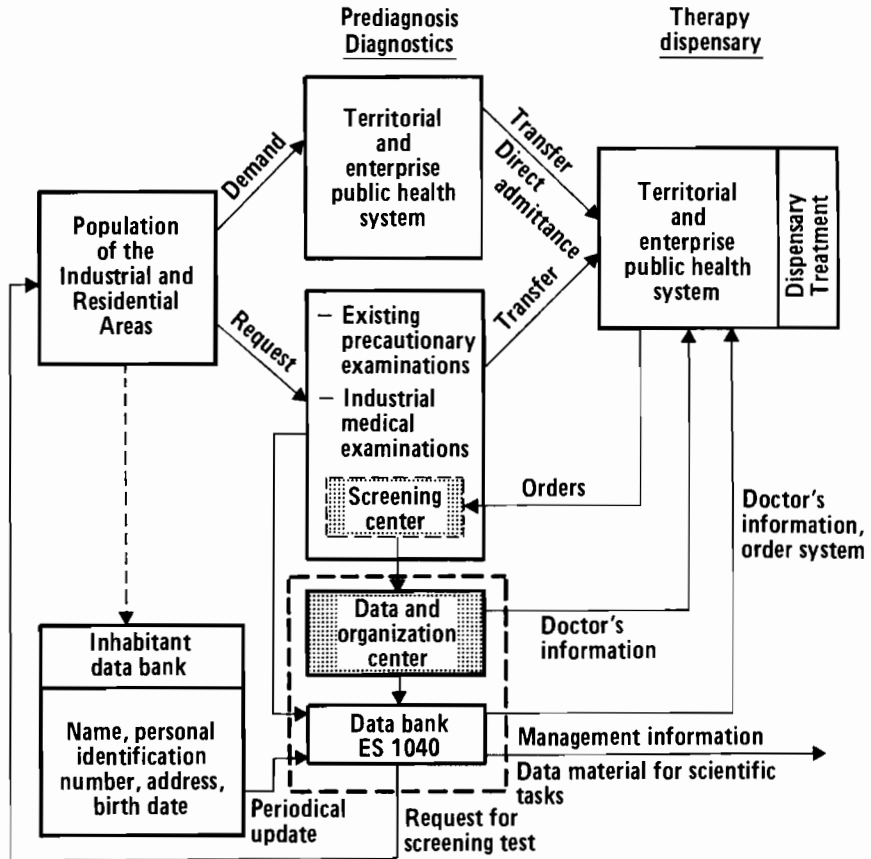

Figure 3. Model of health care in a territory by incorporating centrally organized screening examinations.

EDP Project, "Children and Youth Health Protection"

This project is based on the continuation collection of all data covering the period from birth to discharge from school. Thus doctors can see the results of examinations made at any time within this period. Regular programs of evaluation include: the organization of "mother and child" care (covering the first to the third year), the school entrance examination, the statutory periodic school examination, and the examination on leaving school. Assessments of general morbidity in the young can be made by evaluating the data collected.

If the existing and developing health care and screening systems were utilized several times, it would also result in a

more pronounced standardization of EDP projects. However, in this first phase, with suitable evaluation programs existing, it is already practicable to bring together, within certain limits, the data stored in the individual projects for the purpose of running a model test. In Berlin, the first beginnings have been made on such a complex data evaluation system. But both the expansion of the data base in individual EDP projects and patient-related data banks in selected health care institutions, and also the development of programs to prepare the differently stored data for their application models, make it essential that there be close cooperation between the developers of mathematical models and the competent EDP designers in the GDR. Proceeding from the presently available models, it is essential to work out jointly a program that indicates what parts of the model, with what purpose in mind, should be tested over what periods, for what groups of diseases, and within which territories, in the first phase of this work.

The final aim is the establishment of an institution-related, but also territorially and centrally organized system of medical data banks. The large quantities of data accruing in the process of health care can be utilized effectively for this purpose only by build-up of interrelated, hierarchically structured data banks, or be used for the management and planning of public health.

#### THE HIERARCHY OF DATA BANKS REQUIRED

Organizationally, a distinction is made between (1) automatic patient information systems that are coupled with medical institutions and that handle patient-related diagnosis and treatment documentation, and (2) those patient information systems for controlling the flow of information within institutional and territorial, or central, data banks for management, planning, and research (Figure 4).

The territorial and central data banks are organized in an institution- and patient-related manner, but mainly they store and process only part of the data of each institution. Local control over and supervision of patients is done via patient information systems attached to local institutions. This applies primarily to support rendered for the organization of follow-up treatment and screening programs. In addition, the automated information system of a dispensary treatment or screening facility--structurally separated from hospital or out-patient clinic--can also encompass groups of patients. The territorial data banks include references to the dispensary consulting hours; to the screening check-ups carried out, when a patient is looked after, or identified; and even to potentially selected medical data for dispensary treatment as well as to the results of screening examinations.

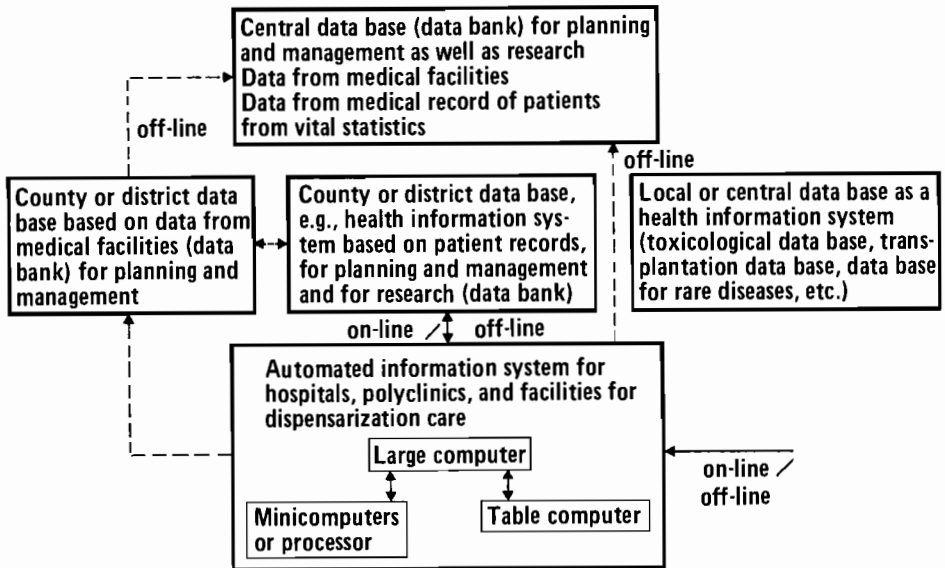

Figure 4. Interactions of the various data banks.

In the central data bank there are, among others, central registers with selected and aggregate data on patients under dispensary treatment, screening programs, etc., for patient-related and group-related evaluations. Data for the territorial and central data banks, to be selected or aggregated according to centrally given criteria, are provided via suitable carriers by the subordinate automated information systems.

Three types of territorial data banks can be distinguished:

1. Patient-related, or person-related, medical data banks (among other uses, as a patient-related inquiry system for hospitals, out-patient clinics, etc., as well as evaluations for management, planning, and research).
2. Institution-related data banks (data on personnel, material and financial funds, or resources of the subordinate hospitals, out-patient clinics, dispensary institutions).
3. Medical reference and inquiry systems (among others, toxicological data banks, transplantation banks, inquiry systems for rare diseases, etc.).

Patient information systems (for hospitals, etc) and territorial data banks of the above type can be operated jointly, for selected territories, e.g. in large-size hospitals, or medical research

institutions. The medical reference and inquiry systems can be operated peripherally or centrally. For the purpose of central management and planning as well as for the sake of central epidemiological research, a data bank has to be established with institution-related data, medical patient-oriented data derived from compulsory reports (e.g., patient's file), as well as data on selected groups of diseases.

FURTHER RESEARCH TASKS TO BE UNDERTAKEN IN COOPERATION WITH IIASA

In view of both the high costs of local data collection and programming and the thus far insufficient data integration, consolidation of the EDP projects mentioned above into territorial and central public health data banks is a long-range goal for the next phase. Presently, there are no territorial and central medical data banks in the GDR, with the exception of a few initial starts. However, such systems could be devised and introduced within the framework of research conducted at IIASA through the two tasks, Computer Information Systems and Modeling Health Care Systems, of the Human Settlements and Services Area (and in cooperation with the Management and Technology and System and Decision Sciences Areas). But it is first essential to prepare a number of studies, or to create the preconditions for them.

The following preconditions are presently being worked out in the GDR:

- A basic classification criterion is required for the introduction of territorially-oriented (patient-related) data banks. In patient-related information processing, the patient constitutes the central reference point of all data to be collected and to be stored and thus determines the basic classification criterion. Each citizen of the GDR has a personal identify number which also provides a clear-cut identification in medical data banks.
- Medical data banks intended to encompass the entire population of selected territories have to be connected with the territorially organized inhabitant data banks under construction. When introducing territorial data banks, each citizen can be identified via his personal identity number and personal data from the inhabitant data banks can be provided in suitable form so as to cut back on the considerable expenditure involved in initial compilation and subsequent error correction. Only by closely cooperating with the inhabitant data banks will it be possible to avoid multiple compilation of personal data and to establish the up-dating operations required permanently within the medical data bank to make changes of personal data (births, deaths, change of name, change of family state, change of residence, etc.). By using the inhabitant data store even the selection of citizens as



well as their call-up can be made with only reasonable expenses, even with an increasing number of activities. The prerequisites necessary for it are presently being provided in the GDR.

Important research tasks are, among others, the following:

1. A clear definition of objectives. This is a prerequisite for the purposeful provision of data for management and planning. Not only the content and scope of data to be stored and processed territorially and centrally, but also the access time, the kind of communication with the data bank, etc., are essentially determined by the tasks to be fulfilled. The diagnostic-therapeutic data required in a territorial data bank for immediate health care of the population are somewhat different from those required for management and planning. Within the field of immediate health care the various sectors, or services, each have their different requirements. Since the kind and scope of data to be collected and stored will always be limited, it would be advisable to have at an early stage detailed statements on the goals and contents of models to be tested.
2. Criteria for the evaluation and efficiency of patient-related data banks in medical institutions. These have to be respecified and possibly supplemented for territorial and central medical data banks. By contrast, the difference between the requirements for patient-related data banks in out-patient and in-patient health institutions is relatively small. For the latter, however, the protection of data and data safety are more important, together with the possibilities of interface with other information systems.
3. Direct links between computers. Computer networks are also necessary for public health. Potential applications are the coupling of automated patient information systems for hospitals, out-patient clinics and follow-up institutions with territorially organized, patient-related data banks and territorial or central data banks used as medical reference systems. In several health care institutions, it is only possible to use medium-sized or even smaller equipment for operating automatic patient-related information systems. By coupling them with a large-sized computer, a temporary expansion of capacity is possible for selected tasks. It is also possible within one and the same facility to transfer specific processing operations (e.g., in an electrocardiogram analysis) partially from the micro- or digital computer to the central computer, within one and the same facility.

4. Organizational concepts. Existing views on organizational concepts have to be further developed for the development of territorial and central data banks. For such applications and in connections with the use of models, the organizational concept is central, since often the system of programs, the data structure, the type of communication, etc., are the same in individual public health institutions.
5. Estimation of public health and of the medical sciences on the basis of comparative analyses of different systems of health care.
6. Comparative analysis of computer-assisted medical information systems.

In addition, the following research should be relevant to other areas and tasks at IIASA:

- Systems analysis for effectively integrating computerized information systems into social organization (health organization, etc.).
- Diffusion of information technology and the impact of informatics on the development of medical sciences and planning and management of health care.
- Review of existing and relevant computer-assisted medical and related urban and regional information systems and analysis of the possibilities of their integration and cooperation.

Within the framework of the health care systems task at IIASA, essentially three lines of research can be delineated for medical information processing:

- establishment of capacity requirements and demands on security and reliability of transfer and operation;
- establishment of demands on access, and the selection of input and output systems, modes of operation and types of access;
- establishment of demands for an international exchange of data.

REFERENCES

- [1] Fuchs-Kittowski, K., H. Friedemann, and P. Gudermuth, Community Screening Systems to Ensure the Data Necessary for a Health Care Model, in E.N. Shigan and R. Gibbs, eds., *Modeling Health Care Systems - Proceedings of an IIASA Workshop*, CP-77-006, International Institute for Applied Systems Analysis, Laxenburg, Austria, 1977.
- [2] Shigan, E.N., *Alternative Analysis of Different Methods for Estimating Prevalence Rate*, RM-77-40, International Institute for Applied Systems Analysis, Laxenburg, Austria, 1977.

MUTUALLY BENEFICIAL INTERNATIONAL SCIENTIFIC  
COLLABORATION IN RESEARCH PROJECTS

Yu.P. Lyachenkov

My particular interest is in how it is possible to organize mutually beneficial scientific collaboration among a group of countries on, for example, tumor immunology in cancer research.

At the present stage of technological progress, it is difficult or almost impossible to attain significant applied scientific results using the potentialities of a single country. One of the chief ways of overcoming this difficulty is organizing bilateral and multilateral mutually beneficial scientific collaboration.

International collaboration, as a research object requiring various forms of international cooperation, is very difficult to analyze as a whole complex (Figure 1). Having selected by means of analytic techniques tumor immunology as one constituent problem of the complex problem of oncology, we then built a model of mutually beneficial international collaboration on this problem. Tumor immunology was selected as the research object for two reasons: (1) because of the importance of cancer research to modern medical science and health care [1-4], and (2) because of the results of systems analysis of cancer research reported at the IIASA Biomedical Conference held in 1975 in Moscow [5-7]. Presented at that conference were the results of structural analysis of informational relationships of research subjects in oncology. An important conclusion from this work was that tumor immunology plays a central role in the system of informational links in cancer research. Thus it was suggested that a more detailed analysis of the structure of research in tumor immunology be carried out.

Using tumor immunology as an example, we developed an approach for planning, organizing, and evaluating the implementation of international medical collaboration (see Figure 2). The block scheme in this figure contains two parts: the process and methodology. The former includes planning, organization, and evaluation and the feedback from evaluation to the planning process, which helps in adjusting the implemented plans. The latter provides methodological support and five information retrieval subsystems (IRS) that are integrated into a combined IRS. However, this paper only deals with the planning process. Organization and evaluation are subjects for further investigation.

The study of tumor immunology began by analyzing a 12-item classification of research subjects adopted by the Scientific

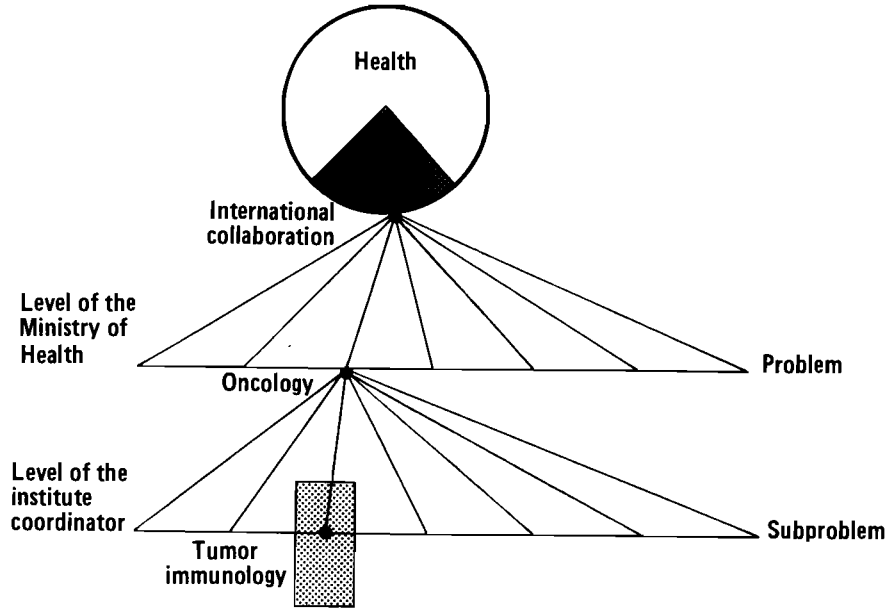

Figure 1. Different levels of research subjects for international collaboration.

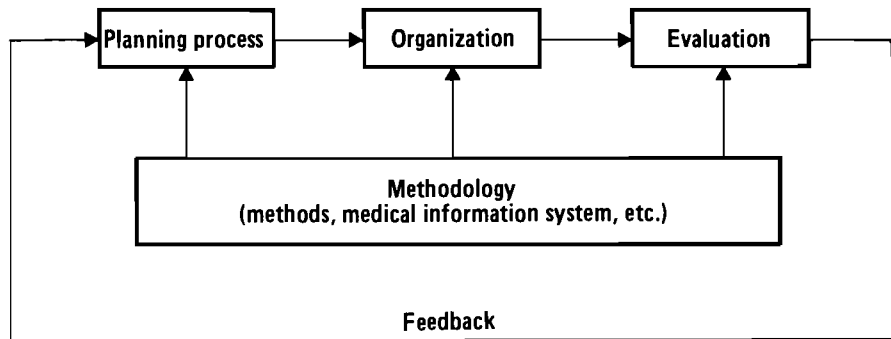

Figure 2. Block-scheme of an approach to planning, organization, and evaluation.

Council on the Complex Problem of "Malignant Neoplasma" of the Presidium of the USSR Academy of Medical Sciences:

1. Antigenic properties of tumor cells (specific tumor, viral, and embryonic antigens).
2. Immunogenicity and immunosensitivity of tumor cells.
3. Interaction of immune lymphocytes and target cells.
4. Immune response mechanism to the generation and growth of a tumor: humoral and cellular factors of specific antitumor immunity.
5. Immunodepression and carcinogenesis.
6. The role of tolerance in the generation of tumors.
7. The immunity tension in oncological patients.
8. Specific immunization against tumors (immunoprevention and immunotherapy).
9. Intensification of the antitumor immunity by methods of nonspecific stimulation (BCG, etc.).
10. Interferon, interferonogenesis, and carcinogenesis.
11. Improving methods of tumor immunodiagnosis.
12. The problem of oncological safety of live viral vaccines and other biocompounds.

The existence of such a classification allows us to assign any research work to one of its headings. It is important to recognize from the scientific point of view the relationship between the present stage of tumor immunology and the management system of this problem. Then we can use economic-mathematical methods for analyzing and planning tumor immunology.

Having compiled this classification, we then determine how much progress has been made in the specific countries on each of the 12 items. The degree of progress can be determined by two independent methods: a subjective method (e.g., expert assessments) and an objective method (i.e., by analyzing the ongoing and/or completed research tasks, publications, patents, dissertations, engaged scientific and support personnel, financing, etc.). Experience has shown that a properly selected, qualified panel usually agrees with the results of objective assessments. Nevertheless, to protect against possible mistakes and to provide mutual corrections, it is very useful to use both methods.

In analyzing the opinions of experts, who are specialists in different research areas, appropriate methods for estimating the consent of their assessments were used.

As for the objective method, we selected three indexes for estimating the degree of research progress in tumor immunology in the group countries: the number of dissertations defended during the last decade, the number of ongoing and completed research tasks during the last three years, and the number of publications the last three years. All three indexes were classified by the classification heading. By processing this data, we can obtain sufficiently reliable estimates of the progress a particular country has made on each of the 12 research subjects (see Figure 3). Then these subjects can be arranged along a certain scale for each country (see Figure 4).

The methodology of comparing the scales using the theory of expert assessments is presently well-developed [8]. When comparing the scales of all countries, we use a matrix of the degree of progress in tumor immunology made by the specified countries. Within this matrix, the rows correspond to the 12 items in the classification and the columns correspond to the countries. In addition, a matrix can be compiled for every country to show the usefulness of sending a specialist from one country to another in each research subject.

At this stage, the problem of allocating resources for visits abroad for each country can be set in terms of mathematical programming [9].

**Specified countries**

<b>Expert assessments</b>									
<b>Assessment of dissertations</b>									
<b>Assessment of research tasks</b>									
<b>Assessment of publications</b>									
<b>Number of scientific workers</b>									
		$\Sigma \downarrow$							

Figure 3. Integrated index of the level of involvement of the specified countries in tumor immunology.

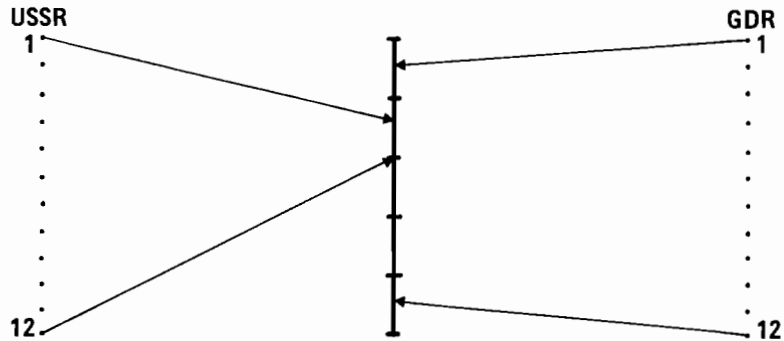

Example. Item 1 in the classification is graded 9 in the GDR and 7 in the USSR; hence visits from the USSR to the GDR may be recommended in this research subject. Item 12 is graded 6 in the USSR and 1 in the GDR; hence visits from the GDR to the USSR may be recommended in this research subject.

Figure 4. Scale of the level of progress in tumor immunology in the USSR and the GDR (ranging and grades are arbitrary).

Thus the methods we propose for organizing international collaboration is to use expert and other approaches. This method can be expanded from one problem (tumor immunology) to a more general, complex problem (malignant neoplasms).

REFERENCES

- [1] World Health Organization, 27th World Health Assembly, *Long-Term Planning of International Cooperation in Cancer Research*, Resolution WHA 27.63, Document A27/VR/14, Geneva, 1974.
- [2] World Health Organization, 28th World Health Assembly, *Long-Term Planning of International Cooperation in Cancer Research*, Resolution WHA 28.85, Document A28/VR/13, Geneva, 1975.
- [3] U.S. Department of Health, Education and Welfare, National Institutes of Health, *National Cancer Program, the Strategic Plan*, 74-569, U.S. Government Printing Office, Washington, D.C., 1973.
- [4] Venedictov, D.D., et al., Development of a Long-Term Program for International Cooperation in Cancer Research, in D.D. Venedictov, ed., *Health System Modeling and the Information System for the Coordination of Research in Oncology*, CP-77-4, International Institute for Applied Systems Analysis, Laxenburg, Austria, 1977.



- [5] Borodkin, L.I., et al., Interrelationships Among Scientific Research Areas--A Step in Developing International Collaborative Programs, in D.D. Venedictov, ed., *Health System Modeling and the Information System for the Coordination of Research in Oncology*, CP-77-4, International Institute for Applied Systems Analysis, Laxenburg, Austria, 1977.
- [6] Borodkin, L.I., I.B. Muchnik, and A.S. Raben, Analysis of a Graph of Citations in Cancer Research Literature, in D.D. Venedictov, ed., *Health System Modeling and the Information System for the Coordination of Research in Oncology*, CP-77-4, International Institute for Applied Systems Analysis, Laxenburg, Austria, 1977.
- [7] Gillis, C.R., Summary on Present and Future Possibilities for International, Intranational and Local Cooperation in Oncological Research and Practice, in D.D. Venedictov, ed., *Health System Modeling and the Information System for the Coordination of Research in Oncology*, CP-77-4, International Institute for Applied Systems Analysis, Laxenburg, Austria, 1977.
- [8] Beshelev, S.D., and F.G. Gurvich, *Matematiko-Statisticheskie Metody Ekspertnykh Otzenok (The Mathematical and Statistical Methods of Expert Assessment)*, Statistika Publishers, Moscow, 1974 (in Russian).
- [9] Judin, D.B., and E.G. Golstein, *Zadachi i Metody Lineynogo Programirovaniya (The Problems and the Methods of Linear Programming)*, 2nd edition, Sovetskoe Radio Publishers, Moscow, 1964 (in Russian).

## DISCUSSION

Dr. Rousseau opened the general discussion about the possibilities of international organizations and national centers collaborating with IIASA by underlying the need for representatives of those institutions to sit down and specify concrete projects. This is a prerequisite for the realization of good intentions. Dr. Lebeux stressed the importance of undertaking modeling tasks that have the potential for real application in other countries.

Dr. McDonald then pointed out that often an international agency does not itself specify the problems it will tackle. Rather, member countries request that specific research tasks be performed. Dr. Bailey explained further that in the case of WHO, the specification of research tasks must be carried out with a certain degree of diplomacy. Often WHO helps developing countries pinpoint concrete problem areas; on the other hand, developed countries frequently call upon WHO to solve a specific problem by means of an informal telephone call.

Dr. Asvall added that a researcher's personal experience in a given country often enables him to identify problem areas. He also noted that WHO's task is to disseminate as well as create information.

Dr. Van der Werff asked whether the aim of IIASA is to perform basic research or to develop and apply streamlined models. Dr. Klementiev replied that IIASA is engaged in both types of tasks.

Dr. McDonald added that often IIASA scientists begin with simple models and develop them in cooperation with national centers. Dr. Gibbs noted that IIASA is in a unique position to synthesize existing information from many nations with regard to a specific problem area.

Dr. Fuchs-Kittowski, Dr. Lyachenkov, Dr. McDonald, Dr. Dent, and Dr. Atsumi then made statements about potential areas for collaboration between IIASA and national centers. Dr. Fuchs-Kittowski stated that the GDR would like to test the IIASA models with its own data. Dr. Lyachenkov spoke about the interest of the Soviet Union in international collaboration in the field of tumor immunology. Dr. McDonald noted that the UK has cooperated with IIASA to a great extent during the past two years, with the result that models being used in his country have been modified and improved. Dr. Dent added that the southwestern regional health authority in the UK may be able to strengthen its liaison

with IIASA by providing data with which to test the health care models. Dr. Atsumi concluded by stating that his home institution in Japan found the IIASA models to be useful and powerful tools. He noted that health authorities in Tokyo and Osaka were interested in cooperative research efforts with IIASA.

Dr. Hartgerink opened the general discussion by asking if health statistics from other countries, such as the GDR, would be available to him. He asked, too, if the IIASA team is prepared to reply by mail to questions and requests for data. Dr. Gibbs replied that, presently, IIASA does not have a strong link with the Netherlands, but would be glad to carry on correspondence with matters of common interest. Dr. Spies added that the Netherlands could certainly learn more about the data collected in the GDR and assess its adaptability for research projects.

Dr. Rousseau then brought up the issue of the "simplicity" of models. He felt that models should be simple to use and understand, but not necessarily simple in structure. He noted that it is possible to drive a car without understanding mechanics, and so in the same manner, users can implement models without necessarily understanding all their complexity.

Dr. Bailey expressed some misgivings about this point of view. He noted that it is always necessary to check a car's brakes. Similarly, models may be dangerous to use if they are not subject to numerous operational checks, such as comparisons of model output with historical data and available forecasts. Dr. McDonald added that model-builders are required to test their models "toward destruction". Dr. Rousseau agreed that model-builders are responsible for controlling the consistency and validity of their models in order to assure that the models are producing reasonable responses to their input.

Dr. Van der Werff then asked if the IIASA models can take into account technological developments. Dr. Gibbs replied that the models cannot answer all questions. Technological assumptions are not taken into consideration explicitly by the models, but can be studied externally.

Next, Dr. Fuchs-Kittowski stated that IIASA's achievements should be stressed and an effort should be made to understand how the health care modeling task fits into IIASA research as a whole. Dr. McDonald agreed that the IIASA team should be congratulated on its progress in carrying out work of great practical significance in an international multidisciplinary setting. Since the 1975 Moscow conference, development of the health care models has been continuous and the value of the conceptual framework has been demonstrated.

Dr. Spies and Dr. Atsumi spoke in favor of expansion of the health care modeling activities. Dr. McDonald asked whether a general consensus exists in support of the development of the project, and the response was very positive. It was agreed that the IIASA Council meeting participants would be notified of this sentiment.



## MODELING HEALTH CARE SYSTEMS

Report of the Conference held November 22-24, 1977  
International Institute for Applied Systems Analysis  
Laxenburg, Austria

The purpose of this conference was to display the ongoing health care systems modeling activities at IIASA and other organizations and research groups, and to discuss future cooperation in this field. Twenty-six individuals, representing research groups in 13 countries, participated, as well as four representatives of WHO.

This conference was divided into six sessions, each devoted to a special aspect of the problem. Session I (E. Shigan, chairman) was devoted to the state-of-the-art in IIASA health care systems (HCS) modeling. The IIASA/HCS model was presented by three speakers: Shigan, R. Gibbs, and A. Klementiev. They said that since adoption of the modeling concepts at the 1975 Biomedical Conference in Moscow and Laxenburg, considerable progress has been made. Submodels have been constructed which, in different combinations, could serve different purposes. Two examples were given: an aggregate model for estimating HCS resource requirements and a disaggregate model of resource allocation. The reports are available in extenso.

In the discussion, the central role of valid assumptions was stressed. For example, concerning the benefits of increased amounts of medical care, it was noted that in principle the model can simulate not only growth but reductions. It was also mentioned that in any case models improve basic knowledge about the actual behavior of the system. The adequacy of "routine data" was also questioned, but it was explained that the model is relatively simple and cannot answer all questions, for example, the effect of technical innovations are not explicitly taken into account within the model. The IIASA model is only a general method--for each nation specific case parameters are needed--but the general framework makes useful comparisons possible. The IIASA team was congratulated on the progress they had made, particularly with regard to the aims of international collaboration, multidisciplinary teamwork, and practical application.

Session II (J. Weiss, USA, chairman) was devoted to HCS modeling in international and national centers. Dr. Bailey (WHO Headquarters) discussed the validity problem of modeling. He stressed that, in addition to a model giving believable results, the consumers should be satisfied and the models should be scientifically respectable. Examples of modeling and operations research (OR) were given from three national centers:

(1) a model of the impact of health service activities using differential equations (A. Petrovsky, USSR), (2) models for resource allocation that were being used in health service planning at national and subnational levels (A. McDonald, UK), and (3) models for several aspects of health services based closely on automated information systems (K. Spies, GDR). A model for analyzing the demand of medical care was presented (S. Kaihara, Japan) and an example of the global equilibrium model of HCS was described (J.-M. Rousseau, Canada).

In the discussion, attention was focused on the problem of awareness and on statistical methods that can be applied, e.g., the equilibrium model.

Session III (N. Bailey, WHO Headquarters, Chairman) was a continuation of the previous session under the same heading. Dr. Weiss presented his personal views concerning the advantages of health care systems modeling. He suspected that modeling could be most useful where technological or biological processes dominated the complex processes underlying politico-medical decisions. Modeling might also identify critical gaps in the empirical knowledge concerning health care systems. An epidemiological model concerning evaluation of the action of risk factors was presented (P. LeBeux, France). The model can be applied, for example, in analyzing the effects of smoking, alcohol, etc., where the risks can be measured. M. Hartgerink (the Netherlands) called attention to the problems of planners and drew special attention to the validity of assumptions and to the difficulties in their testing. Å. Andersson (Sweden) presented a model concerning work absenteeism and morbidity. Preliminary results indicate that the four classes of explanatory variables used--individual characteristics, housing, work place, and transportation system--can explain logically some effects of environment on health. He also drew attention to equilibrium phenomena and to the fact that smooth trends can trigger sudden discontinuous changes.

In the discussion it was noted that the topics are difficult because not all the participants have the same orientation: there seems to be a marked distance between mathematical models and practical problems of decisionmakers. It was mentioned that often the models give right answers but wrong questions are asked. Modeling efforts might be more successful if aimed at narrower objectives. Yet, modeling helps one understand how a system works and a priori assumptions can be corrected. It also helps planners look at the consequences of policies and bring more rationality into the decisionmaking system. The present objectives of the IIASA project are more models than in earlier stages but they have shown that they have universal usefulness.

Session IV (K. Spies, GDR, Chairman) was devoted to the development of national HCS models. IIASA staff explained the future development of HCS modeling (E. Shigan) and examples of socio-economic factors influencing health and health care modeling (P. Fleissner). A model that makes it possible to estimate

and compare the cost of medical care in different countries was described (K. Atsumi, Japan), along with a model of environmental influences of health (R. Miksl, Czechoslovakia), and a project to analyze the economic aspects of ambulatory care (W. van Eimeren, FRG) were described. Y. Komarov (USSR) discussed modeling the HCS in large cities. A model related to antialcoholism program planning was also described (L. Wasserman, USA).

The discussion focused on the phenomena of biased information that can make routine data useless. Too much information makes their value questionable, and it was mentioned that smaller amounts of reliable data are preferable. The reason for data unreliability is that often they are based only on legal requirements and there is no other motivation to fill out the basic forms. Yet, it was noted that some speakers were probably too critical of routine information. It was felt that the main benefit of studying the different models presented was their didactic value, their basic ideas, experiences gained, and knowledge of attitudes of researchers, which are useful to everybody.

Session V (J.-M. Rousseau, Canada, Chairman) was devoted to "Planning Health Care Systems--the Planner's Requirements for Models". C. Graham (UK) presented the background of present activities in the UK, and especially the use of modeling in resource allocation between regions. A. Van der Werff (the Netherlands) described the recent innovations in the organizational structure that make it possible to introduce health planning at regional and national levels in the Netherlands. A.S. Härö (Finland) discussed planners' roles, different strategies for action, and development of information services. Mandil (WHO Headquarters) presented the activities being undertaken to improve the information system serving WHO's projects and other activities.

During the discussion, attention was devoted to the motivations for changes in the HCS. A favorable change in political climate is required and a formalized statement of objectives is also very important. It was also noted that planners are especially interested in strategic models. In addition, the strategic planner needs a variety of submodels that are more or less self-contained and oriented differently, but are nevertheless interrelated and belong to the same "model family". The use of models in planning makes the functional aspects of HCS understandable and helps planners form a realistic picture of present circumstances. It was also mentioned that it is sometimes easier to introduce major reorganization than make small improvements in the system and its planning functions.

Session VI (A. McDonald, UK, Chairman) concentrated on the problems of "Collaboration with National and International Centers" and on general conclusions. WHO's possible role in future collaboration was described by N. Bailey (WHO Headquarters) and J. Asvall (EURO). It was stressed that one area of cooperation concerns the

methods, approaches, and even practical arrangements that are needed to introduce the principles of systems approach, modeling, etc., to the present generation of national decisionmakers and health politicians. Another important area to be considered is the implementation of HCS models in developing countries. A related area for cooperation is the country health programming (CHP) activity initiated in numerous countries and comparable methods applied to projects (PSA).

Collaboration with national centers was presented by K. Fuchs-Kittowski (GDR), who indicated the value of regionally made analyses of HCS and research for comparison of health care systems in differently organized countries. Cooperation in the field of informatics could also be developed. Y. Lyachenkov (USSR) presented a method to plan the use of resources for international collaboration in research and development projects. A. McDonald (UK) stressed the educative aspects of cooperation. N. Dent (UK) described regional applications of modeling as a possible area for cooperative actions. K. Atsumi (Japan) described the present and future activities in Japan and more broadly in southern Asia in the field of information systems development. Cooperation with IIASA and WHO is very important in these projects.

In the discussion the numerous positive aspects of cooperative actions were stressed and participants of several research groups (e.g., GDR, FRG, Japan, UK, Canada, etc.) expressed their intentions to test the IIASA models in their national settings. It was mentioned that the conference had achieved its objectives and had, furthermore, fulfilled the purpose of having closer contacts between national research groups and with IIASA. The participants of the conference recommended the continuation of the health care systems modeling project at IIASA and the expansion of the effort to cover areas that have not yet been analyzed.

The conference was closed by E. Shigan.

#### CONCLUDING REMARKS

On the basis of presented papers and remarks made during discussions, we arrive at the following conclusions:

- In the health field there are many problems requiring the systems approach and modeling activities.
- International cooperation in this field is very useful and IIASA's role as coordinator and initiator is extremely important.
- IIASA's general approach to HCS modeling was, in principle, seen as purposeful and no major changes were recommended.
- There has been considerable progress and the project has developed well, considering the limited resources



available. It was recommended that with expanded staffing of the project, more attention should be devoted to those aspects of the socioeconomic and physical environment that influence health and health services.

- The models developed by IIASA should be systematically tested under actual conditions in countries having differently organized service systems. This would help make the IIASA models more universal, but at the same time more flexible, for example, in relation to needed data.
- For pragmatic cooperative action in health care modeling, a network of contact persons, or "liason officers", could play a decisive and useful role. The existing formal connections of IIASA are not always suited to this purpose.
- It was recommended that IIASA devote attention to the problem of making more generally known the basic principles and "the way of thinking" that is the essence of systems analysis. The present generation of administrators and decisionmakers have, for the most part, not been trained in this respect which, for example, complicates the cooperation in modeling activities.

A.S. Härö  
Finland  
Rapporteur to  
the Conference



## CONCLUDING ADDRESS

E.N. Shigan

During the three days of our international conference, we had the opportunity to listen to reports reflecting the progress in health care systems modeling at national and international centers and at IIASA. Around the conference table, specialists from many countries had the chance to exchange opinions, experience, and perspectives about the development of health care systems modeling. The conference proved persuasively the necessity for international and interdisciplinary approaches to solving common problems. Taking into account the fact that the models are oriented toward them, the active participation of decisionmakers in the model building process is very important.

In conclusion, let me thank all participants from the national member organizations; Drs. Bailey, Korneev, and Mandil from WHO Headquarters; and Dr. Asvall from the WHO Regional Office for Europe for their contributions. I would also like to thank the rapporteur of this conference, Dr. Härö, for preparation of the constructive final conference report; and the director of IIASA, Dr. Levien; the chairman of HSS, Professor Rogers; and the staff members of IIASA for participation and help in organizing and conducting this conference.



## APPENDICES



APPENDIX A

List of Participants and  
Contributing Authors

Åke Andersson  
Department of Economics  
University of Gothenburg  
Fack  
S-40010 Gothenburg  
Sweden

J.E. Asvall  
Regional Office for Europe  
World Health Organization  
8, Scherfigsvej  
DK-2100 Copenhagen Ø  
Denmark

Kazuhiko Atsumi  
Institute for Medical  
Electronics  
Faculty of Medicine  
University of Tokyo  
7-3-1 Hongo, Bunkyo-ku  
Tokyo 113  
Japan

Norman T.J. Bailey  
World Health Organization  
1211 Geneva 27  
Switzerland

Walter Buchstaller  
Federal Ministry of Health and  
Environmental Protection  
Department of Health  
Organization, Health  
Statistics and Data  
Processing  
Stubenring 1  
1010 Vienna  
Austria

Jacques Chaperon  
GERSS, INSERM U 88  
91, bd de l'Hôpital  
75634 Paris Cedex 13  
France

Neil A. Dent  
South Western Regional Health  
Authority  
27 TynDalls Park Road  
Bristol  
United Kingdom

Clemens Dietrich  
Industrieanlagen-  
Betriebsgesellschaft m.b.H.  
Einsteinstrasse  
D-8012 Ottobrunn  
Federal Republic of Germany

Wilhelm van Eimeren  
Institut für Medizinische  
Informationsverarbeitung,  
Statistik und Biomathematik ISB  
Marchioninstrasse 15  
8000 Munich 70  
Federal Republic of Germany

Peter Fleissner  
International Institute for  
Applied Systems Analysis  
2361 Laxenburg  
Austria

Klaus Fuchs-Kittowski  
Humboldt-Universität zu Berlin  
August-Bebel-Platz (Kommde)  
102 Berlin  
German Democratic Republic

Iwao Fujimasa  
Institute for Medical  
Electronics  
Faculty of Medicine  
University of Tokyo  
7-3-1 Hongo, Bunkyo-ku  
Tokyo 113  
Japan

Richard J. Gibbs  
International Institute for  
Applied Systems Analysis  
2361 Laxenburg  
Austria

Marcel Goldberg  
GERSS, INSERM U 88  
91, bd de l'Hôpital  
75634 Paris Cedex 13  
France

Paquerette Goldberg  
GERSS, INSERM U 88  
91, bd de l'Hôpital  
75634 Paris Cedex 13  
France

Clifford Graham  
Department of Health  
and Social Security  
Euston Tower  
Euston Road  
London NW1  
United Kingdom

F. Gremy  
INSERM U 88  
91, bd de l'Hôpital  
75634 Paris Cedex 13  
France

P. Gudermuth  
Humboldt-Universität zu Berlin  
Autust-Bebel-Platz (Kommode)  
102 Berlin  
German Democratic Republic

Aarne S. Härö  
The National Board of Health  
Siltasaarekatu 18A  
00530 Helsinki 53  
Finland

Martin Hartgerink  
Netherlands Institute for  
Preventive Health Care  
Wassanarse weg 56  
Leiden  
The Netherlands

Ingvar Holmberg  
Demographic Research Institute  
Viktoriagatan 13  
41125 Gothenburg  
Sweden

Shigekoto Kaihara  
Hospital Computer Center  
7 Hongo, Bunkyo-ku  
Tokyo 113  
Japan

Pavel I. Kitsul  
International Institute for  
Applied Systems Analysis  
2361 Laxenburg  
Austria

Alexandre A. Klementiev  
International Institute for  
Applied Systems Analysis  
2361 Laxenburg  
Austria

W. Koepcke  
Institute für Medizinische  
Informationsverarbeitung,  
Statistik und Biomathematik ISB  
Marchioninistrasse 15  
8000 Munich 70  
Federal Republic of Germany

Yuri Komarov  
Institute of Complex Problems  
of Hygiene and Occupational  
Diseases  
Academy of Medical Sciences  
of the USSR  
ul. Solnyanka, 14  
Moscow  
USSR

Yuri Korneev  
Division of Environmental  
Health  
World Health Organization  
1211 Geneva 27  
Switzerland

Mårten Lagergren  
Spri  
Sehlstedtsgratan 9  
Fack  
102 50 Stockholm  
Sweden

Pierre Le Beux  
Université Paris 1  
12 Place du Pantheon  
75231 Paris Cedex 05  
France



Yuri Lyachenkov  
Ministry of Health  
of the USSR  
Rachmanovski per. 2  
Moscow  
USSR

Salah Mandil  
Information Systems Progress  
World Health Organization  
1211 Geneva 27  
Switzerland

Alex G. McDonald  
Operational Research Unit  
Department of Health  
and Social Security  
151 Great Titchfield Street  
London W1P 8AD  
United Kingdom

Raimund Miksl  
Regional Hygienic Station  
Ostrava  
Institute for Industrial  
Landscape Ecology of the  
Czechoslovak Academy of  
Sciences  
Partizan Place No. 7  
728 92 Ostrava 1  
Czechoslovakia

Wladyslaw Olshansky  
Institute of Control Sciences  
Academy of Sciences, USSR  
Profsoyuznaya, 81  
Moscow, V-279  
USSR

Hans Otto  
Institut für Sozialhygiene  
und Organisation des  
Gesundheitsschutzes  
Nölder Strasse 34-36  
1134 Berlin  
German Democratic Republic

Alexander Petrovsky  
Institute of Control Sciences  
Academy of Sciences, USSR  
Profsoyuznaya, 81  
Moscow, V-279  
USSR

Alexander A. Romensky  
The Central Institute of  
Public Health  
Ministry of Health of the USSR  
Rachmanovski per. 2  
Moscow  
USSR

Jean-Marc Rousseau  
Departement d'Informatique  
et Recherche Opérationnelle  
Université de Montréal  
C.P. 6128  
Montreal, Quebec  
Canada

Evgenii N. Shigan  
International Institute for  
Applied Systems Analysis  
2361 Laxenburg  
Austria

Konstantin Spies  
Ministry of Health of the GDR  
Rathausstrasse 3  
102 Berlin  
German Democratic Republic

Dimitri D. Venedictov  
Ministry of Health of the USSR  
Rachmanovski per. 3  
Moscow  
USSR

Lawrence Wasserman  
National Institute on Alcohol  
Abuse and Alcoholism  
Division of Prevention  
Room 14C-24  
Rockville, Maryland  
USA

Jeffrey H. Weiss  
Downstate Medical Center  
State University of New York  
450 Clarkson Avenue  
Brooklyn, New York 11203  
USA

Albert van der Werff  
Ministry of Public Health  
and Environment  
Dr. Reijersstraat 12  
Leidschendam  
The Netherlands

C. Veyssier  
UTC, B.P. 233  
Compiègne  
France

Anatoli J. Yashin  
Institute of Control Sciences  
Academy of Sciences, USSR  
Profsoyuznaya, 81  
USSR

APPENDIX B

Agenda

TUESDAY, NOVEMBER 22

Welcoming Address  
R.E. Levien, Director, IIASA

Welcoming Address  
A. Rogers, Chairman, Human Settlements and Services Area

*Session I: State-of-the-Art in the IIASA Health  
Care Systems (HCS) Modeling Task*

The IIASA Health Care System Model  
D.D. Venedictov (USSR)

The Components of the IIASA Health Care System Model  
R.J. Gibbs (IIASA)

Aggregate Model for Estimating Health Care System Resources  
A.A. Klementiev (IIASA)

A Disaggregated Health Care Resource Allocation Model  
R.J. Gibbs (IIASA)

Discussion

*Session II: HCS Modeling by International and National Centers*

The Role of Validity in Health Care System Modeling  
N.T.J. Bailey (WHO)

Modeling of Large Systems  
A. Petrovsky (USSR)

System Modeling and Health Service Planning in the UK  
A.G. McDonald (UK)

Analysis and Future Estimation of Medical Demands by Means  
of a Health Care Simulation Model  
S. Kaihara (Japan)

Towards a Global Equilibrium Model for Health Care System  
Planning  
J.-M. Rousseau (Canada)

National Aspects of Health Care Systems Modeling in the GDR  
K. Spies (GDR)

Discussion

WEDNESDAY, NOVEMBER 23

*Session III: HCS Modeling by International and National  
Centers (continued)*

The Utility of National Health Care System Modeling: One  
Planner's View  
J.H. Weiss (USA)

An Epidemiological Model to Evaluate the Action  
of a Risk Factor  
P. Le Beux (France)

Health Care System Upside-Down and Downside-Up  
M. Hartgerink (The Netherlands)

Discussion

Demonstration of Interactive Use of IIASA Computer Models

*Session IV: Development of the National HCS Model*

Future Directions for the IIASA HCS Modeling Task  
E.N. Shigan (IIASA)

Socio-Economic Factors Affecting the HCS  
P. Fleissner (IIASA)

Medical Demand Model to Estimate Medical Care Cost  
K. Atsumi (Japan)

Health Index as a Critical Function for Basic Model of Human  
Environment  
R. Miksl (Czechoslovakia)

Modeling the Bavarian Ambulatory Care System--An  
Interdisciplinary Effort  
W. van Eimeren (FRG)

Health Information Systems and Their Meaning in  
the Modeling Processes of Large Cities  
Y. Komarov (USSR)

Discussion

Remote Use of the IIASA Computer Model  
A. Butrimenko and M. Ziak (IIASA)

THURSDAY, NOVEMBER 24

*Session V: Planning Health Care Systems--The Planner's  
Requirements for Models*

The Planning System of the UK National Health Service  
C. Graham (UK)

Health Care System Planning  
A.S. Härö (Finland)

Discussion

*Session VI: Collaboration with National and International  
Centers*

Collaboration with the WHO Headquarters  
N.T.J. Bailey (WHO)

The WHO Information System Development  
S. Mandil (WHO)

Collaboration with EURO WHO  
J. Asvall (WHO)

Collaboration with National Centers

- GDR (K. Fuchs-Kittowski)
- USSR (Y. Lyachenkov)
- UK (A.G. McDonald)
- Japan (K. Atsumi)

Final Discussion

Rapporteur Report

